

# C1608X8R1H333M080AA

TDK Item Description : C1608X8R1H333MT\*\*\*\*



## Application & Main Feature

Commercial Grade ( High Temperature Application )

## Series

C1608 [EIA CC0603]

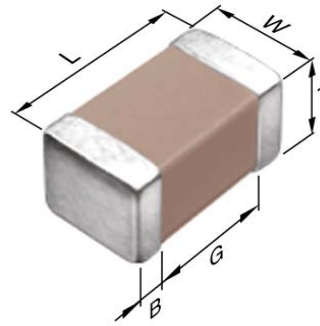

## Dimensions

L 1.60mm +/-0.1mm  
 W 0.80mm +/-0.1mm  
 T 0.80mm +/-0.1mm  
 B 0.20mm Min.  
 G 0.30mm Min.

## Temperature Characteristic

X8R (-55 to 150 degC +/-15%)

## Rated Voltage

1H (50Vdc)

## Capacitance

33nF

## Capacitance Tolerance

M (+/-20%)

## Dissipation Factor

3% Max.

## Insulation Resistance

10Gohm Min.

## AEC-Q200

Not Applicable

## DC Bias Characteristic

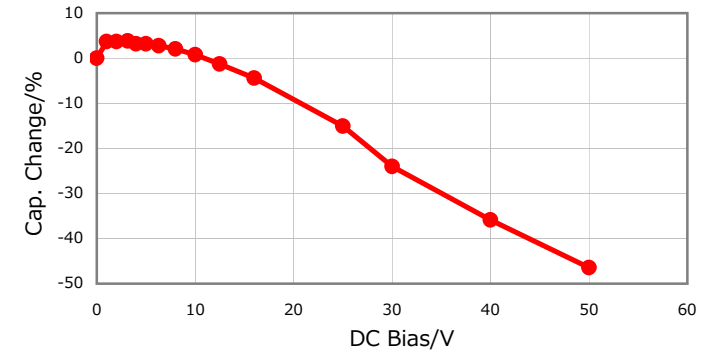

## |Z|, ESR vs. Freq. Characteristics

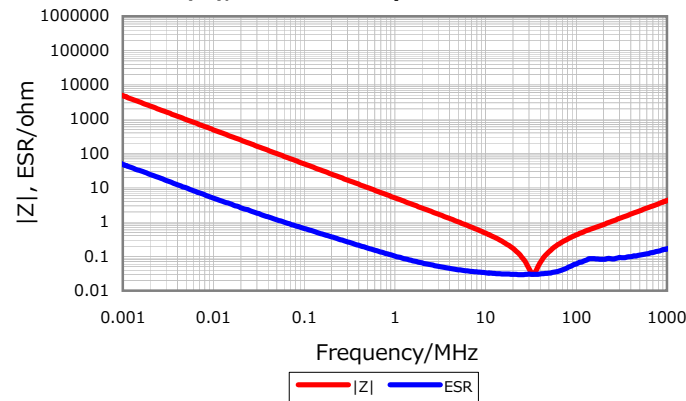

## Temperature Characteristics

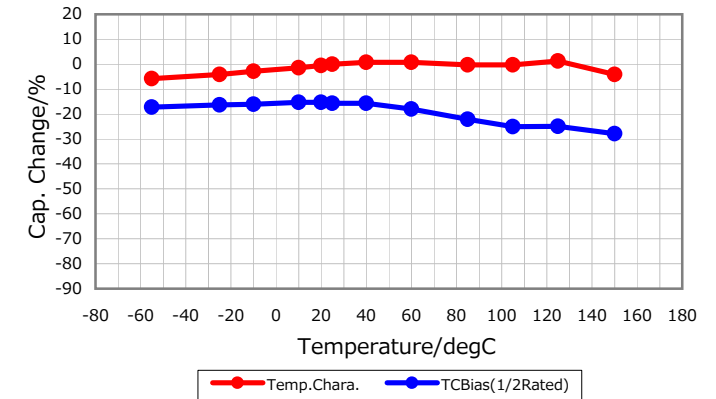

## Cap. vs. Freq. Characteristic

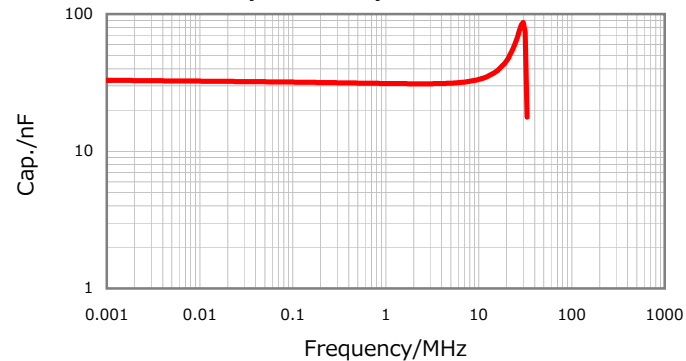

## Ripple Temperature Rise Characteristics

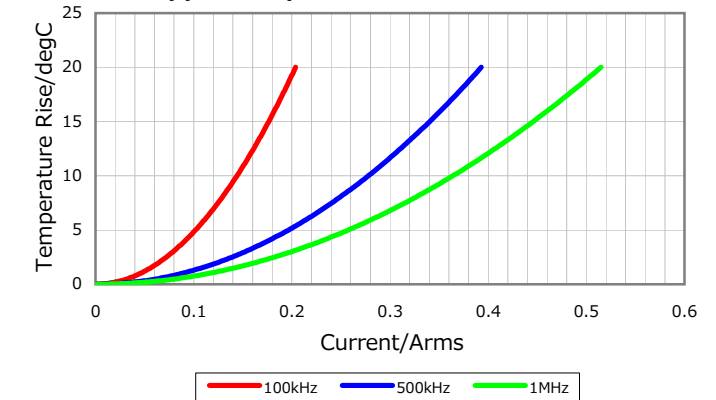

Characterization Sheet ( Multilayer Ceramic Chip Capacitors )



All specifications are subject to change without notice.

January 3, 2016