

MLX90217

Hall-Effect Geartooth Sensor
Datasheet

General description

Features & benefits

- Geartooth Sensor
- Zero Speed Detection
- Insensitive to Orientation
- Short Circuit Protection
- Self-Adjusting Magnetic Range
- On-chip 10 bit A/D Converter
- High Speed Operation
- No Chopper Delay

Applications examples

- Geartooth Sensor
- Speed Sensor
- Camshaft Sensor
- Direction Detection (see applications example)

Description

The MLX90217 is a self-adjusting digital output rotary position gear tooth sensor designed for use in automotive camshaft sensing as well as other speed sensing applications. It is designed to be used with a bias magnet south facing the back (non-marked) side of the IC. The device has an open collector output which is short circuit protected.

The MLX90217 is a sophisticated IC featuring an on-chip 10-bit A/D Converter and logic that acts as a digital sample and hold circuit. A separate 4-bit A/D converter provides a fixed hysteresis. The 90217 does not have a chopper delay. The 90217 uses a single Hall plate which is immune to rotary alignment problems. The bias magnet can be from 50 to 400mT.

As the signal is sampled, the logic recognizes an increasing or decreasing flux density. The output will turn on (BOP) after the flux has reached its peak and decreased by an amount equal to the hysteresis. Similarly, the output will turn off (BRP) after the flux has reached its minimum value and increased by an amount equal to the hysteresis.

Functional Diagram

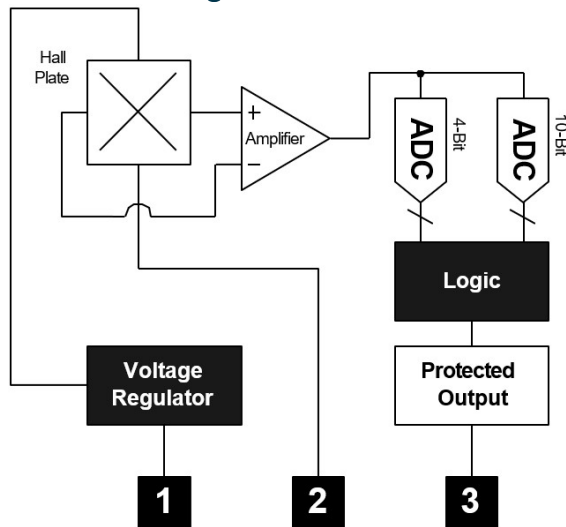

Pin 1: V_{DD} (Supply)
Pin 2: V_{SS} (Ground)
Pin 3: Output

Note: Static sensitive device, please observe ESD precautions.

MLX90217

Hall-Effect Geartooth Sensor
Datasheet



Ordering information

Product code	Temperature	Package	Application	Packing
MLX90217LUA-CAA-000-BU	-40 to 150 °C	UA	3.5mT typical hysteresis	BU
MLX90217LUA-CCA-000-BU	-40 to 150 °C	UA	5.5mT typical hysteresis	BU

Table 1 – Product codes

MLX90217LUA-CAA-000-BU

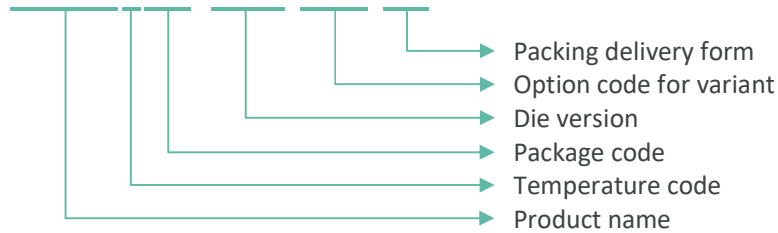

Absolute Maximum Ratings

DC Operating Parameters $T_A = -40^{\circ}\text{C}$ to 150°C , $V_{DD} = 3.5\text{V}$ to 24V (unless otherwise specified).

Parameter	Symbol	Min.	Max.	Unit	Condition
Supply Voltage	V_{DD}		30	V	Operating
Supply Current	I_{DD}		50	mA	Fault
Output Current	I_{OUT}		30	mA	Fault
Output Current	I_{FAULT}		50	mA	Fault
Output Voltage	V_{OUT}		30	V	
Power Dissipation	P_D		100	mW	
Operating Temperature	T_A	-40	150	$^{\circ}\text{C}$	
Storage Temperature	T_S	-65	150	$^{\circ}\text{C}$	
Junction Temperature	T_J		175	$^{\circ}\text{C}$	

Table 2 – Absolute Maximum Ratings

Electrical Specifications

DC Operating Parameters $T_A = -40^{\circ}\text{C}$ to 150°C , $V_{DD} = 3.5\text{V}$ to 24V (unless otherwise specified).

Parameter	Symbol	Min.	Typ.	Max.	Unit	Condition
Supply Voltage	V_{DD}	3.5	-	24	V	Operating
Supply Current	I_{DD}	1.5	3.0	4.5	mA	$V_{DD} = 12\text{V}$
Supply Current	I_{DD}	1	-	6	mA	$V_{DD} = 3.5\text{V}$ to 24V
Leakage Current	I_{LEAK}	-	-	10	μA	$V_{OUT} = 3.5\text{V}$ to 24V
Output Current	I_{OUT}	-	-	25	mA	Operating
Output Saturation Voltage	V_{SAT}	-	-	600	mV	$V_{DD} = 12\text{V}$, $I_{OUT} = 25\text{mA}$
Output Short Circuit Current	I_{FAULT}	50	100	150	mA	Fault
Output Short Circuit Shutdown	T_{FAULT}	100	-	200	s	Fault
Clock Frequency	f_{CLK}	300	500	800	kHz	Operating
Output Rise Time	t_r		-	400	ns	$V_{DD} = 12\text{V}$, $R_1 = 880\Omega$, $C_1 = 20\text{pf}$
Output Fall Time	t_f		-	400	ns	$V_{DD} = 12\text{V}$, $R_1 = 880\Omega$, $C_1 = 20\text{pf}$
Bandwidth	BW	-	-	15	kHz	Operating
Thermal Resistance	R_{TH}	-	-	200	$^{\circ}\text{C}/\text{W}$	Operating

Table 3 – Electrical Specifications

Magnetic Specifications

DC Operating Parameters $T_A = -40^{\circ}\text{C}$ to 150°C , $V_{DD} = 3.5\text{V}$ to 24V (unless otherwise specified).

1mT = 10Gauss

Parameter	Symbol	Min.	Typ.	Max.	Unit	Condition
Back Bias Range	B_{BIAS}	-30	-	400	mT	Operating
Linear Region	B_{LIN}	50	-	500	mT	$V_{DD} = 12\text{V}$
Hysteresis	B_{HYS}	1.8	3.5	10	mT	CAA-000
Hysteresis	B_{HYS}	3.8	5.5	12	mT	CCA-000

Table 4 – Magnetic Specifications

MLX90217

Hall-Effect Geartooth Sensor
Datasheet



Performance Graphs

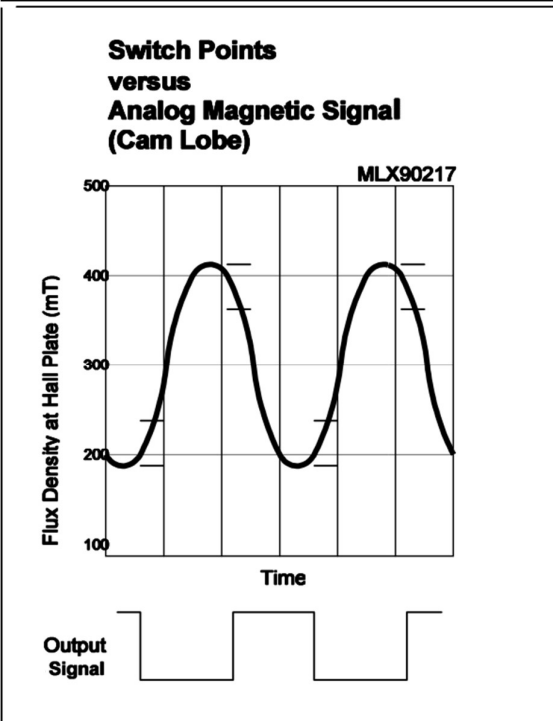
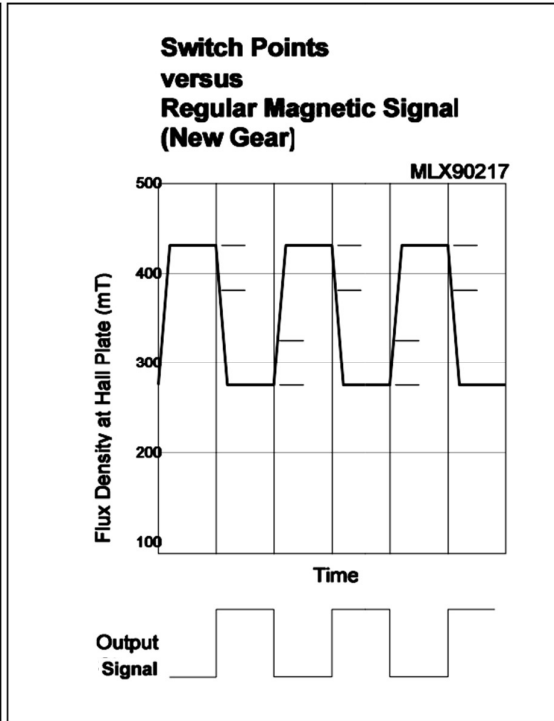
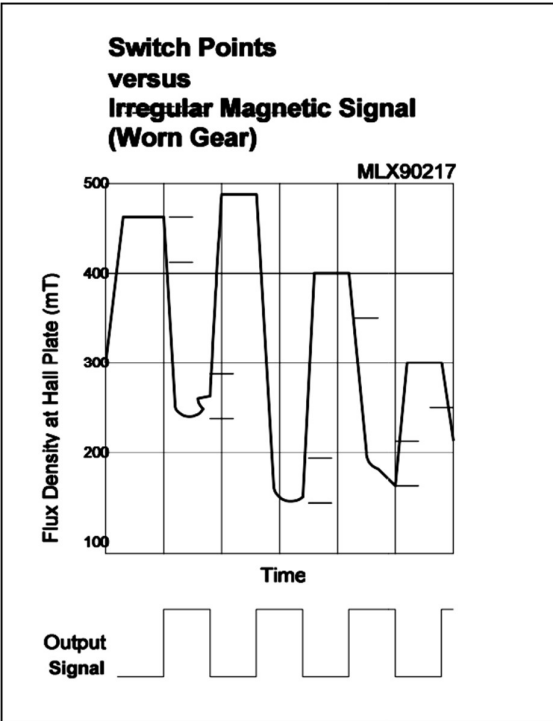

MLX90217

Hall-Effect Geartooth Sensor
Datasheet



Application Notes

Maximum dynamic range is 500mT. The hysteresis is fixed at 5.0mT. Best angular accuracy will be obtained when the magnetic circuit provides peak magnetic flux at the chip near the high end of the linear range of 500mT. EMC protections using external components are recommended. Two possibilities are shown on the following page. Normally the South pole faces the unbranded side of the device. A North pole will enable a test sequence used in factory testing.

Unique Features

The output is reset to the high-Z state at power on (output driver is off) whatever the field is. The output only changes after the first min is detected. The reset state holds no information about the field. If the supply of the chip is raised slowly, the reset state is not stable. This has been observed at 0 field but it should be the same with small and large fields.

Gear tooth sensors often need to be adjusted after the module is assembled to align the magnet with differential Hall plates or orient with teeth. However, the MLX90217 is "self-adjusting" over a wide range of back bias flux eliminating the need for any trimming in the application. The magnet may be glued to the back surface (non-branded side) of the IC using a cyanoacrylate adhesive or suitable epoxy.

MLX90217

Hall-Effect Geartooth Sensor
Datasheet

Application Examples

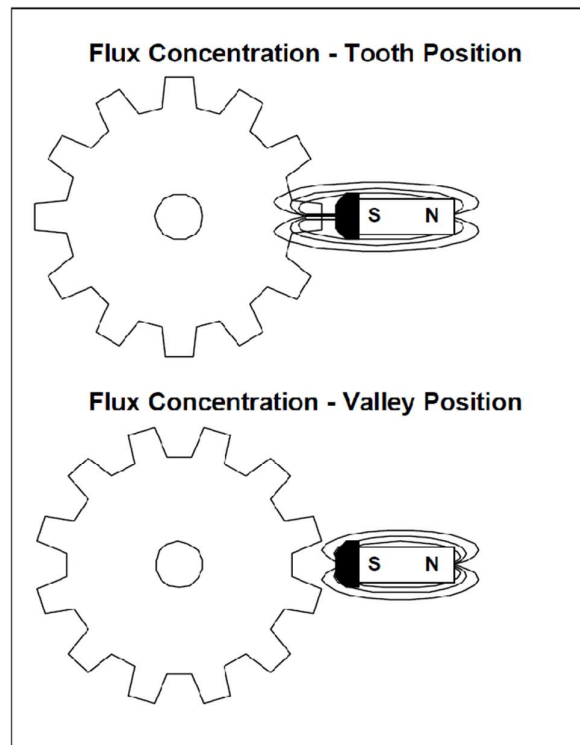
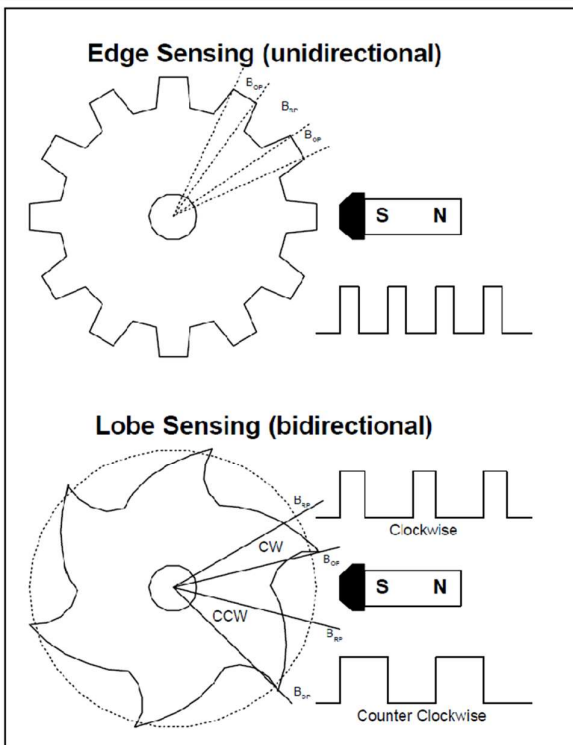
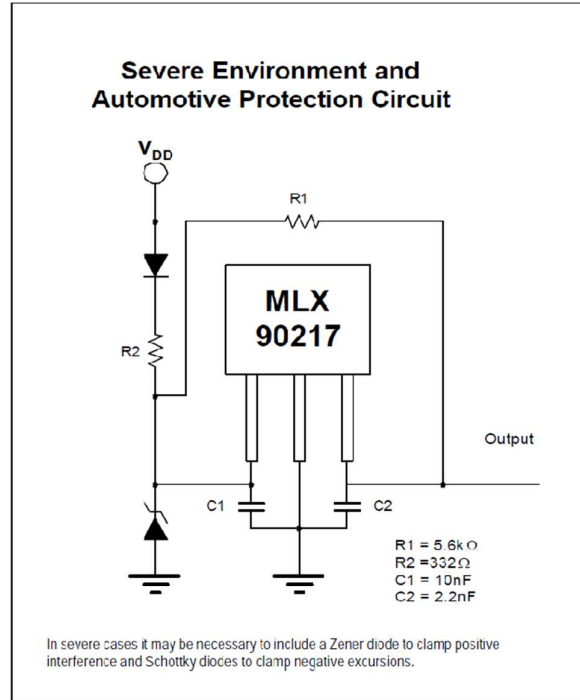
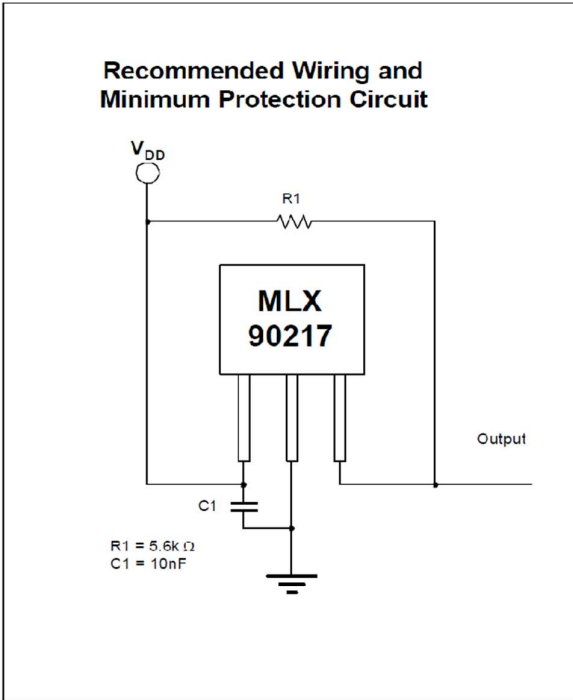

MLX90217

Hall-Effect Geartooth Sensor
Datasheet



Physical Characteristics

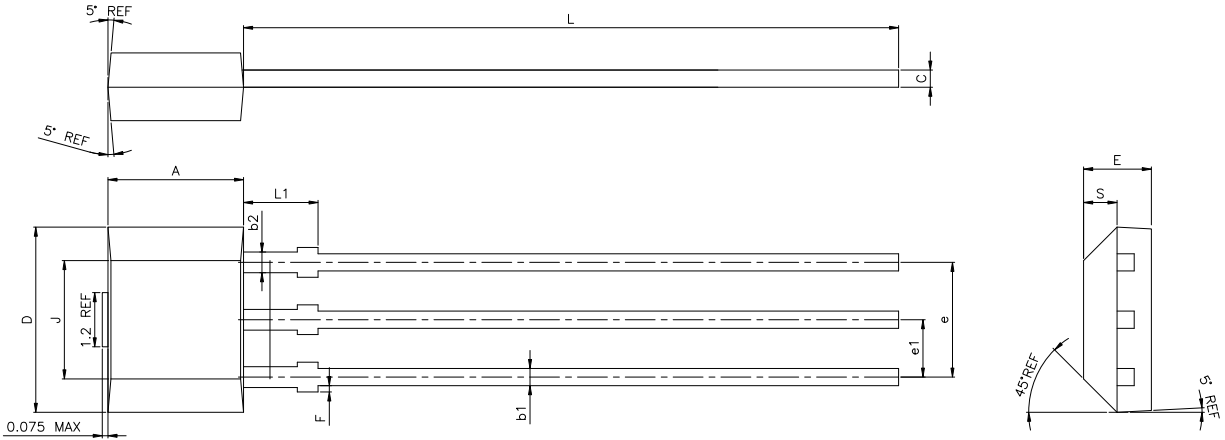

SYMBOL	MINIMUM	MAXIMUM
A	2.90	3.10
D	4.00	4.20
E	1.40	1.60
F	0.00	0.20
J	2.51	2.72
L	14.00	15.00
L1	1.55	1.75
S	0.63	0.84
b1	0.35	0.44
b2	0.43	0.52
c	0.35	0.44
e	2.51	2.57
e1	1.24	1.30

NOTE :

1. DIMENSIONS IN MILLIMETERS (mm) UNLESS NOTED OTHERWISE.
2. PACKAGE DIMENSIONS DO NOT INCLUDE MOLD FLASHES AND PROTRUSIONS.
3. DIMENSION A AND D DO NOT INCLUDE MOLD GATE AND SIDE FLASH (PROTRUSION) OF MAXIMUM 0.127 mm PER SIDE.
4. THE LEADS MAY BE SLIGHTLY DEFORMED DURING TRANSPORTATION IF PACKED IN BULK (BAG), AFFECTING e1 DIMENSION. IT IS RECOMMENDED TO ORDER RADIAL TAPE (REEL OR AMMOPACK) IF SUCH DEFORMATION IS CRITICAL FOR THE LEAD FORMING PROCESS, EVEN IF MANUAL LOADING INTO THE TOOL IS FORESEEN.

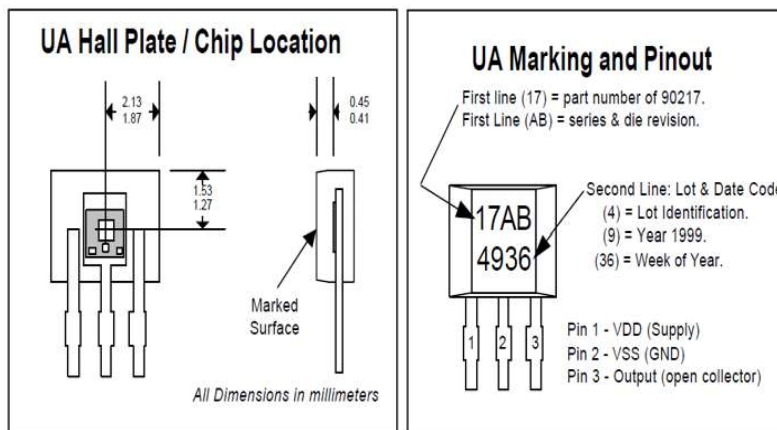

Note: When parts are shipped in bulk (bag) LSL / USL limits on e and e1 are not applicable and dimensions should be considered as a reference value.

Standard information regarding manufacturability of Melexis products with different soldering processes

Our products are classified and qualified regarding soldering technology, solderability and moisture sensitivity level according to following test methods:

Reflow Soldering SMD's (Surface Mount Devices)

- IPC/JEDEC J-STD-020
Moisture/Reflow Sensitivity Classification for Nonhermetic Solid-State Surface Mount Devices (classification reflow profiles according to table 5-2)
- EIA/JEDEC JESD22-A113
Preconditioning of Non-hermetic Surface Mount Devices Prior to Reliability Testing (reflow profiles according to table 2)

Wave Soldering SMD's (Surface Mount Devices) and THD's (Through Hole Devices)

- EN60749-20
Resistance of plastic- encapsulated SMD's to combined effect of moisture and soldering heat
- EIA/JEDEC JESD22-B106 and EN60749-15
Resistance to soldering temperature for through-hole mounted devices

Iron Soldering THD's (Through Hole Devices)

- EN60749-15
Resistance to soldering temperature for through-hole mounted devices

Solderability SMD's (Surface Mount Devices) and THD's (Through Hole Devices)

- EIA/JEDEC JESD22-B102 and EN60749-21
Solderability

For all soldering technologies deviating from above mentioned standard conditions (regarding peak temperature, temperature gradient, temperature profile etc) additional classification and qualification tests have to be agreed upon with Melexis.

The application of Wave Soldering for SMD's is allowed only after consulting Melexis regarding assurance of adhesive strength between device and board.

Melexis is contributing to global environmental conservation by promoting **lead free** solutions. For more information on qualifications of **RoHS** compliant products (RoHS = European directive on the Restriction Of the use of certain Hazardous Substances) please visit the quality page on our website:

<http://www.melexis.com/quality.aspx>

ESD Precautions

Electronic semiconductor products are sensitive to Electro Static Discharge (ESD).

Always observe Electro Static Discharge control procedures whenever handling semiconductor products.

MLX90217

Hall-Effect Geartooth Sensor
Datasheet



Revision History

Revision	Date	Change history
011	02-Sep-25	Updated package drawing, new template, layout and cleanup of text

Table 5 – Revision History

Disclaimer

The content of this document is believed to be correct and accurate. However, the content of this document is furnished "as is" for informational use only and no representation, nor warranty is provided by Melexis about its accuracy, nor about the results of its implementation. Melexis assumes no responsibility or liability for any errors or inaccuracies that may appear in this document. Customer will follow the practices contained in this document under its sole responsibility. This documentation is in fact provided without warranty, term, or condition of any kind, either implied or expressed, including but not limited to warranties of merchantability, satisfactory quality, non-infringement, and fitness for purpose. Melexis, its employees and agents and its affiliates' and their employees and agents will not be responsible for any loss, however arising, from the use of, or reliance on this document. Notwithstanding the foregoing, contractual obligations expressly undertaken in writing by Melexis prevail over this disclaimer.

This document is subject to change without notice, and should not be construed as a commitment by Melexis. Therefore, before placing orders or prior to designing the product into a system, users or any third party should obtain the latest version of the relevant information.

Users or any third party must determine the suitability of the product described in this document for its application, including the level of reliability required and determine whether it is fit for a particular purpose.

This document as well as the product here described may be subject to export control regulations. Be aware that export might require a prior authorization from competent authorities. The product is not designed, authorized or warranted to be suitable in applications requiring extended temperature range and/or unusual environmental requirements. High reliability applications, such as medical life-support or life-sustaining equipment or avionics application are specifically excluded by Melexis. The product may not be used for the following applications subject to export control regulations: the development, production, processing, operation, maintenance, storage, recognition or proliferation of:

- 1. chemical, biological or nuclear weapons, or for the development, production, maintenance or storage of missiles for such weapons;*
- 2. civil firearms, including spare parts or ammunition for such arms;*
- 3. defense related products, or other material for military use or for law enforcement;*
- 4. any applications that, alone or in combination with other goods, substances or organisms could cause serious harm to persons or goods and that can be used as a means of violence in an armed conflict or any similar violent situation.*

No license nor any other right or interest is granted to any of Melexis' or third party's intellectual property rights.

If this document is marked "restricted" or with similar words, or if in any case the content of this document is to be reasonably understood as being confidential, the recipient of this document shall not communicate, nor disclose to any third party, any part of the document without Melexis' express written consent. The recipient shall take all necessary measures to apply and preserve the confidential character of the document. In particular, the recipient shall (i) hold document in confidence with at least the same degree of care by which it maintains the confidentiality of its own proprietary and confidential information, but no less than reasonable care; (ii) restrict the disclosure of the document solely to its employees for the purpose for which this document was received, on a strictly need to know basis and providing that such persons to whom the document is disclosed are bound by confidentiality terms substantially similar to those in this disclaimer; (iii) use the document only in connection with the purpose for which this document was received, and reproduce document only to the extent necessary for such purposes; (iv) not use the document for commercial purposes or to the detriment of Melexis or its customers. The confidentiality obligations set forth in this disclaimer will have indefinite duration and in any case they will be effective for no less than 10 years from the receipt of this document.

This disclaimer will be governed by and construed in accordance with Belgian law and any disputes relating to this disclaimer will be subject to the exclusive jurisdiction of the courts of Brussels, Belgium.

The invalidity or ineffectiveness of any of the provisions of this disclaimer does not affect the validity or effectiveness of the other provisions.

The previous versions of this document are repealed.

Melexis © - No part of this document may be reproduced without the prior written consent of Melexis. (2025)

IATF 16949 and ISO 14001 Certified

For the latest revision of this document, visit www.melexis.com/MLX90217

Happy to help you! www.melexis.com/contact