

Overview

KEMET's General Purpose encapsulated radial leaded ceramic disc capacitors are specifically designed for DC and pulse high voltage applications. These capacitors are well-suited for applications that require bypassing, coupling and decoupling for example for X-ray sources and pulsed lasers.

These capacitors consist of a ceramic disc both sides of which are silver/copper plated and connection leads are made of tinned copper steel wire with straight, vertical kink, outside kink and inside kink leads. This series is available in SL, Y5P, Y5U and Y5V dielectrics.

Benefits

- Operating temperature range SL: -55°C to +125°C
- Operating temperature range Y5P, Y5U and Y5V: -25°C to +125°C
- DC voltage ratings of 1 KV, 2 KV, 3 KV, 4 KV, 6 KV, 8 KV and 10KV
- Capacitance offerings ranging from 5.1 pF up to 10 nF
- Available capacitance tolerances of $\pm 5\%$, $\pm 10\%$, and $\pm 20\%$
- 5.0 mm, 7.5 mm, 10 mm, and 12.5mm lead spacing
- Preformed (crimped) or straight lead configurations
- Lead(Pb)-free and RoHS Compliant
- Halogen-free
- Non-polar device, minimizing installation concerns

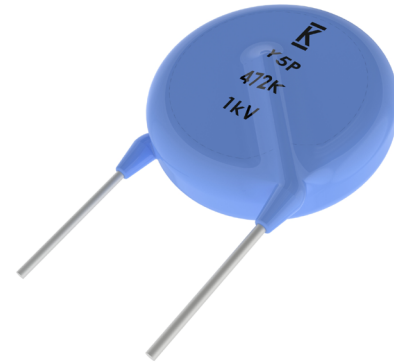

Applications

- Bypassing, coupling, and decoupling
- DC and pulse high voltage
- DC Ballast
- High voltage power supplies
- Airpurifier / ionizer
- DC blocking
- Switching power supplies

Radial Leaded Ceramic Disc Capacitors

General Purpose Disc, CGP Series, 1,000 - 10,000 VDC (Commercial Grade)

Ordering Information

CGP	5	C	103	M	D	V	D	A	A	7301
Ceramic Series	Lead Spacing	Specification/ Series	Capacitance Code (pF)	Capacitance Tolerance	Rated Voltage (VDC)	Dielectric/ Temp. Char.	Design	Lead Configuration ^{1,2}	Failure Rate	Packaging (C-Spec)
CGP = Ceramic General Purpose	5 = 5.0 mm 7 = 7.5 mm 1 = 10.0 mm 2 = 12.5 mm	C = Standard	Two significant digits and Number of zeroes	J = ±5% K = ±10% M = ±20%	D = 1,000 G = 2,000 H = 3,000 U = 4,000 K = 6,000 L = 8,000 N = 10,000	S = SL Y = Y5P W = Y5U V = Y5V	D = Disc	A = Straight B = Vertical Kink C = Outside Kink D = Inside Kink	A = N/A	See "Packaging C-Spec Ordering Options Table" below

¹ Due to a high risk of arcing, "Inside Kink" lead configuration cannot be combined with the 5 mm lead spacing option. The "Inside Kink" option is only available on capacitors with lead spacing of 7.5 mm or greater. A potential for arcing may exist when combining the "Inside Kink" lead configuration with a 7.5 mm lead spacing option, especially in high humidity environments and/or when exposure to voltages and transients may impact creepage and clearance requirements. (Review PN List)

² Bulk packaging lead length availability is dependent upon "Lead Configuration" and "Lead Spacing." See "Dimensions" section of this document to verify availability of a specific lead length option. For nonstandard lead length inquiries, please contact KEMET.

Packaging C-Spec Ordering Options Table

Packaging Type ³	Lead Length (mm) ¹	Packaging Ordering Code (C-Spec)
Reel	See Note 2	7301
Ammo Pack		7317
Bulk Bag ⁴	3.5 ±1.0	WL35
	5.0 ±1.0	WL50
	25.0 mm Minimum	WL25

¹ For nonstandard lead length inquiries, please contact KEMET.

² Lead length for ammo and reel pack packaging is defined by the H and H0 dimensions in Table 3.

³ For rated voltage ≥ 8 kV or body diameter (D) > 16 mm, Bulk bag is the only packaging option available

⁴ For rated voltage >6 kV, WL25 is the only packaging option available

Radial Leaded Ceramic Disc Capacitors

General Purpose Disc, CGP Series, 1,000 - 10,000 VDC (Commercial Grade)

Lead Configurations

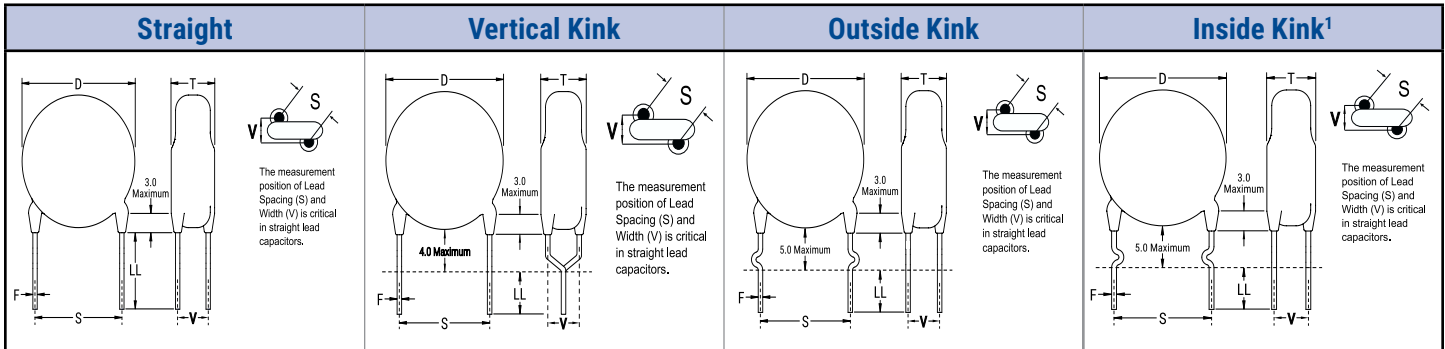

¹ Due to a high risk of arcing, the "Inside Kink" lead configuration option cannot be combined with 5 mm lead spacing ("S" dimension above). The "Inside Kink" option is only available on devices with lead spacing of 7.5 mm, 10 mm, or 12.5 mm.

Dimensions – Millimeters

Lead Configuration	Lead Configuration Ordering Code ¹	S	Lead Spacing Tolerance	D	T	V	F
		Lead Spacing ²		Body Diameter ²	Body Thickness	Width	Lead Diameter
Straight	A	5.0	±1.0	See Table 1 - "Product Ordering Codes and Ratings"		1KV = 1.5±0.5 2KV = 1.7±0.5 3 & 4KV = 2.1±0.5 5 & 6KV = 2.7±0.5 8KV = 4.3±0.5 10KV = 4.9±0.5	1kV - 6kV = 0.60±0.1 >6KV = 0.80±0.1
		7.5					
		10.0					
		12.5					
Vertical Kink (Preformed)	B	5.0					
		7.5					
		10.0					
		12.5					
Outside Kink (Preformed)	C	5.0					
		7.5					
		10.0					
		12.5					
Inside Kink (Preformed)	D	7.5					
		10.0					
		12.5					

¹ Lead Configuration is identified in the 13th character of the ordering code. See "Lead Configuration" and "Ordering Information" sections of this document for further details.

² Body diameter of capacitor will limit available lead spacing and packaging options. See "Product Ordering Codes and Ratings" sections of this document for further details.

Radial Leaded Ceramic Disc Capacitors

General Purpose Disc, CGP Series, 1,000 - 10,000 VDC (Commercial Grade)

Lead Configurations

Item	SL	Y5P	Y5U	Y5V
Operating Temperature Range	-55°C to +125°C	-25°C to +125°C		
Capacitance Change with Reference to +25°C and 0 Vdc Applied (TCC)	+350ppm/°C / -1000ppm/°C	±10%	+22% / -56%	+22% / -82%
¹ Dielectric Withstanding Voltage (DWV)	2 - 3kV: 200% of rated voltage >3kV - 5kV: 175% of rated voltage >5kV: 150% of rated voltage (5 ± 1 seconds and charge/discharge not exceeding 50mA)			
Dissipation Factor (DF) Maximum Limit @ 25°C	Quality Factor (Q) ' ≥ 1,000 for capacitance values ≥30 pF ≥ 400 + 20C for capacitance values <30pF (C = Capacitance in pF) 1MHz ± 100kHz and 1.0 ± 0.2 Vrms	Dissipation Factor (DF) 2.5% 1kHz ± 50Hz and 1.0 ± 0.2 Vrms		
Insulation Resistance (IR) Minimum Limit @ 25°C	100GΩ (500 VDC applied for 60 ± 5 secs @ 25°C)			

¹DWV is the voltage a capacitor can withstand (survive) for a short period of time. It exceeds the nominal and continuous working voltage of the capacitor.

²Capacitance and dissipation factor (DF) measured under the following conditions:

1kHz ± 50Hz and 1.0 ± 0.2 Vrms if capacitance ≤10μF

120Hz ± 10Hz and 0.5 ± 0.1 Vrms if capacitance >10μF

Environmental Compliance

These devices are Halogen-free and RoHS Compliant. They meet all requirements set forth by both EU and China RoHS directives.



Radial Leaded Ceramic Disc Capacitors

General Purpose Disc, CGP Series, 1,000 - 10,000 VDC (Commercial Grade)

Table 1A – Product Ordering Codes and Ratings - SL Dielectric

Dielectric/ Temp. Char.	Rated Voltage (VDC)	KEMET Part Number	Capacitance	Capacitance Tolerance	Dimensions (mm)		Lead Spacing				
					Body Diameter (Maximum)	Body Thickness (Maximum)					
SL	1,000	CGP(1)C330(2)DSD(3)A(4)	33 pF	±10%	5.5	4	5.0 mm 7.5 mm 10.0 mm 12.5 mm				
		CGP(1)C360(2)DSD(3)A(4)	36 pF								
		CGP(1)C390(2)DSD(3)A(4)	39 pF								
		CGP(1)C430(2)DSD(3)A(4)	43 pF								
		CGP(1)C470(2)DSD(3)A(4)	47 pF								
		CGP(1)C510(2)DSD(3)A(4)	51 pF								
		CGP(1)C560(2)DSD(3)A(4)	56 pF								
		CGP(1)C620(2)DSD(3)A(4)	62 pF								
		CGP(1)C680(2)DSD(3)A(4)	68 pF								
		CGP(1)C750(2)DSD(3)A(4)	75 pF								
		CGP(1)C820(2)DSD(3)A(4)	82 pF								
		CGP(1)C910(2)DSD(3)A(4)	91 pF								
		CGP(1)C101(2)DSD(3)A(4)	100 pF								
		CGP(1)C121(2)DSD(3)A(4)	120 pF								
		CGP(1)C151(2)DSD(3)A(4)	150 pF								
		CGP(1)C181(2)DSD(3)A(4)	180 pF								
		CGP(1)C221(2)DSD(3)A(4)	220 pF								
		CGP(1)C271(2)DSD(3)A(4)	270 pF								
	2,000	CGP(1)C150(2)GSD(3)A(4)	15 pF		±10%	5.5		5			
		CGP(1)C160(2)GSD(3)A(4)	16 pF								
		CGP(1)C180(2)GSD(3)A(4)	18 pF								
		CGP(1)C200(2)GSD(3)A(4)	20 pF								
		CGP(1)C220(2)GSD(3)A(4)	22 pF								
		CGP(1)C240(2)GSD(3)A(4)	24 pF								
		CGP(1)C270(2)GSD(3)A(4)	27 pF								
		CGP(1)C300(2)GSD(3)A(4)	30 pF								
		CGP(1)C330(2)GSD(3)A(4)	33 pF								
		CGP(1)C360(2)GSD(3)A(4)	36 pF								
		CGP(1)C390(2)GSD(3)A(4)	39 pF								
		CGP(1)C430(2)GSD(3)A(4)	43 pF								
		CGP(1)C470(2)GSD(3)A(4)	47 pF								
		CGP(1)C510(2)GSD(3)A(4)	51 pF								
		CGP(1)C560(2)GSD(3)A(4)	56 pF								
		CGP(1)C620(2)GSD(3)A(4)	62 pF								
		CGP(1)C680(2)GSD(3)A(4)	68 pF								
		CGP(1)C750(2)GSD(3)A(4)	75 pF								
		CGP(1)C820(2)GSD(3)A(4)	82 pF								
		CGP(1)C910(2)GSD(3)A(4)	91 pF								
		CGP(1)C101(2)GSD(3)A(4)	100 pF								
		3,000	CGP(1)C100(2)HSD(3)A(4)			10 pF			±10%	6.5	5
			CGP(1)C150(2)HSD(3)A(4)			15 pF					
			CGP(1)C220(2)HSD(3)A(4)			22 pF					
CGP(1)C330(2)HSD(3)A(4)	33 pF										
CGP(1)C390(2)HSD(3)A(4)	39 pF										
CGP(1)C470(2)HSD(3)A(4)	47 pF										

(1) To properly complete ordering code, insert the one-digit numeric code to reflect required lead spacing:

(Note that select capacitance values and packaging options may limit lead spacing availability. See table above to verify availability.)

5 = 5.0 mm 7 = 7.5 mm 1 = 10.0 mm 2 = 12.5 mm

(2) To properly complete ordering code, insert the one-digit character code to reflect the required capacitance tolerance:

J = ±5% K = ±10%

(3) To properly complete ordering code, insert the one-digit character code to reflect the required lead configuration: (See "Lead Configuration" section of this document, for further details.)

A = Straight B = Vertical Kink C = Outside Kink D = Inside Kink

(4) To properly complete ordering code, enter the four-digit numeric or alphanumeric "Packaging C-Spec Ordering Code." See "Dimensions" section of this document, for available options.

Radial Leaded Ceramic Disc Capacitors

General Purpose Disc, CGP Series, 1,000 - 10,000 VDC (Commercial Grade)

Table 1A – Product Ordering Codes and Ratings - SL Dielectric cont.

Dielectric/ Temp. Char.	Rated Voltage (VDC)	KEMET Part Number	Capacitance	Capacitance Tolerance	Dimensions (mm)		Lead Spacing
					Body Diameter (Maximum)	Body Thickness (Maximum)	
SL	3,000	CGP(1)C560(2)HSD(3)A(4)	56 pF	±10%	7.5	5	5.0 mm 7.5 mm 10.0 mm 12.5 mm
		CGP(1)C680(2)HSD(3)A(4)	68 pF		8.5		
		CGP(1)C100(2)USD(3)A(4)	10 pF		6.5		
	CGP(1)C150(2)USD(3)A(4)	15 pF					
	CGP(1)C220(2)USD(3)A(4)	22 pF					
	CGP(1)C330(2)USD(3)A(4)	33 pF					
	CGP(1)C390(2)USD(3)A(4)	39 pF					
	CGP(1)C470(2)USD(3)A(4)	47 pF					
	4,000	CGP(1)C560(2)USD(3)A(4)	56 pF		7.5		
		CGP(1)C680(2)USD(3)A(4)	68 pF		8.5		
		CGP(1)C100(2)KSD(3)A(4)	10 pF		7.5		
		CGP(1)C150(2)KSD(3)A(4)	15 pF				
		CGP(1)C220(2)KSD(3)A(4)	22 pF				
		CGP(1)C330(2)KSD(3)A(4)	33 pF				
	CGP(1)C390(2)KSD(3)A(4)	39 pF					
	CGP(1)C470(2)KSD(3)A(4)	47 pF					
	6,000	CGP(1)C560(2)KSD(3)A(4)	56 pF		10.5		
		CGP(1)C680(2)KSD(3)A(4)	68 pF		8.5		
		CGP(1)C100(2)LSD(3)A(4)	10 pF		6		
		CGP(1)C150(2)LSD(3)A(4)	15 pF				
		CGP(1)C220(2)LSD(3)A(4)	22 pF				
		CGP(1)C330(2)LSD(3)A(4)	33 pF				
	CGP(1)C390(2)LSD(3)A(4)	39 pF					
	CGP(1)C470(2)LSD(3)A(4)	47 pF					
8,000	CGP(1)C560(2)LSD(3)A(4)	56 pF	12.0				
	CGP(1)C680(2)LSD(3)A(4)	68 pF	8.5				
	CGP(1)C100(2)LSD(3)A(4)	10 pF	8				
	CGP(1)C150(2)LSD(3)A(4)	15 pF					
	CGP(1)C220(2)LSD(3)A(4)	22 pF					
	CGP(1)C330(2)LSD(3)A(4)	33 pF					
CGP(1)C390(2)LSD(3)A(4)	39 pF						
CGP(1)C470(2)LSD(3)A(4)	47 pF						
Dielectric/ Temp. Char.	Rated Voltage (VDC)	KEMET Part Number	Capacitance	Capacitance Tolerance	Body Diameter (Maximum)	Body Thickness (Maximum)	Lead Spacing

(1) To properly complete ordering code, insert the one-digit numeric code to reflect required lead spacing:

(Note that select capacitance values and packaging options may limit lead spacing availability. See table above to verify availability.)

5 = 5.0 mm 7 = 7.5 mm 1 = 10.0 mm 2 = 12.5 mm

(2) To properly complete ordering code, insert the one-digit character code to reflect the required capacitance tolerance:

J = ±5% K = ±10%

(3) To properly complete ordering code, insert the one-digit character code to reflect the required lead configuration: (See "Lead Configuration" section of this document, for further details.)

A = Straight B = Vertical Kink C = Outside Kink D = Inside Kink

(4) To properly complete ordering code, enter the four-digit numeric or alphanumeric "Packaging C-Spec Ordering Code." See "Dimensions" section of this document, for available options.

Radial Leaded Ceramic Disc Capacitors

General Purpose Disc, CGP Series, 1,000 - 10,000 VDC (Commercial Grade)

Table 1B – Product Ordering Codes and Ratings - Y5P Dielectric

Dielectric/ Temp. Char.	KEMET Part Number	Rated Voltage (VDC)	Capacitance	Capacitance Tolerance	Dimensions (mm)		Lead Spacing		
					Body Diameter (Maximum)	Body Thickness (Maximum)			
Y5P	CGP(1)C101(2)DYD(3)A(4)	1,000	100 pF	±10% ±20%	5.5	4	5.0 mm 7.5 mm 10.0 mm 12.5 mm		
	CGP(1)C121(2)DYD(3)A(4)		120 pF						
	CGP(1)C151(2)DYD(3)A(4)		150 pF						
	CGP(1)C181(2)DYD(3)A(4)		180 pF						
	CGP(1)C221(2)DYD(3)A(4)		220 pF						
	CGP(1)C271(2)DYD(3)A(4)		270 pF						
	CGP(1)C331(2)DYD(3)A(4)		330 pF						
	CGP(1)C391(2)DYD(3)A(4)		390 pF						
	CGP(1)C471(2)DYD(3)A(4)		470 pF						
	CGP(1)C561(2)DYD(3)A(4)		560 pF						
	CGP(1)C681(2)DYD(3)A(4)		680 pF						
	CGP(1)C821(2)DYD(3)A(4)		820 pF						
	CGP(1)C102(2)DYD(3)A(4)		1000 pF						
	CGP(1)C122(2)DYD(3)A(4)		1200 pF						
	CGP(1)C152(2)DYD(3)A(4)		1500 pF						
	CGP(1)C182(2)DYD(3)A(4)		1800 pF						
	CGP(1)C222(2)DYD(3)A(4)		2200 pF						
	CGP(1)C272(2)DYD(3)A(4)		2700 pF						
	CGP(1)C332(2)DYD(3)A(4)	3300 pF							
	CGP(1)C392(2)DYD(3)A(4)	3900 pF							
	CGP(1)C472(2)DYD(3)A(4)	4700 pF							
	CGP(1)C101(2)GYD(3)A(4)	2,000	100 pF		6.5	5			
	CGP(1)C121(2)GYD(3)A(4)		120 pF						
	CGP(1)C151(2)GYD(3)A(4)		150 pF						
	CGP(1)C181(2)GYD(3)A(4)		180 pF						
	CGP(1)C221(2)GYD(3)A(4)		220 pF						
	CGP(1)C271(2)GYD(3)A(4)		270 pF						
	CGP(1)C331(2)GYD(3)A(4)		330 pF						
	CGP(1)C391(2)GYD(3)A(4)		390 pF						
	CGP(1)C471(2)GYD(3)A(4)		470 pF						
	CGP(1)C561(2)GYD(3)A(4)		560 pF						
	CGP(1)C681(2)GYD(3)A(4)		680 pF						
	CGP(1)C821(2)GYD(3)A(4)		820 pF						
	CGP(1)C102(2)GYD(3)A(4)		1000 pF						
	CGP(1)C122(2)GYD(3)A(4)		1200 pF						
	CGP(1)C152(2)GYD(3)A(4)		1500 pF						
	CGP(1)C182(2)GYD(3)A(4)		1800 pF						
	CGP(1)C222(2)GYD(3)A(4)		2200 pF						
	CGP(1)C272(2)GYD(3)A(4)		2700 pF						
	CGP(1)C332(2)GYD(3)A(4)	3300 pF							
	CGP(1)C392(2)GYD(3)A(4)	3900 pF							
	CGP(1)C472(2)GYD(3)A(4)	4700 pF							
	CGP(1)C101(2)HYD(3)A(4)	3,000	100 pF		6.5	6.5			
	CGP(1)C121(2)HYD(3)A(4)		120 pF						
	CGP(1)C151(2)HYD(3)A(4)		150 pF						
	CGP(1)C181(2)HYD(3)A(4)		180 pF						
	CGP(1)C221(2)HYD(3)A(4)		220 pF						
	CGP(1)C271(2)HYD(3)A(4)		270 pF						
CGP(1)C331(2)HYD(3)A(4)	330 pF								
CGP(1)C391(2)HYD(3)A(4)	390 pF								
CGP(1)C471(2)HYD(3)A(4)	470 pF								
CGP(1)C561(2)HYD(3)A(4)	560 pF								
CGP(1)C101(2)HYD(3)A(4)	100 pF		7.5	7.5					
CGP(1)C121(2)HYD(3)A(4)	120 pF								
CGP(1)C151(2)HYD(3)A(4)	150 pF								
CGP(1)C181(2)HYD(3)A(4)	180 pF								
CGP(1)C221(2)HYD(3)A(4)	220 pF								
CGP(1)C271(2)HYD(3)A(4)	270 pF								
CGP(1)C331(2)HYD(3)A(4)	330 pF								
CGP(1)C391(2)HYD(3)A(4)	390 pF								
CGP(1)C471(2)HYD(3)A(4)	470 pF								
CGP(1)C561(2)HYD(3)A(4)	560 pF								
Dielectric/ Temp. Char.	KEMET Part Number	Rated Voltage (VDC)			Capacitance	Capacitance Tolerance	Body Diameter (Maximum)	Body Thickness (Maximum)	Lead Spacing

(1) To properly complete ordering code, insert the one-digit numeric code to reflect required lead spacing:

(Note that select capacitance values and packaging options may limit lead spacing availability. See table above to verify availability.)

5 = 5.0 mm 7 = 7.5 mm 1 = 10.0 mm 2 = 12.5 mm

(2) To properly complete ordering code, insert the one-digit character code to reflect the required capacitance tolerance:

K = ±10% M = ±20%

(3) To properly complete ordering code, insert the one-digit character code to reflect the required lead configuration: (See "Lead Configuration" section of this document, for further details.)

A = Straight B = Vertical Kink C = Outside Kink D = Inside Kink

(4) To properly complete ordering code, enter the four-digit numeric or alphanumeric "Packaging C-Spec Ordering Code." See "Dimensions" section of this document, for available options.

Radial Leaded Ceramic Disc Capacitors

General Purpose Disc, CGP Series, 1,000 - 10,000 VDC (Commercial Grade)

Table 1B – Product Ordering Codes and Ratings - Y5P Dielectric cont.

Dielectric/ Temp. Char.	KEMET Part Number	Rated Voltage (VDC)	Capacitance	Capacitance Tolerance	Dimensions (mm)		Lead Spacing	
					Body Diameter (Maximum)	Body Thickness (Maximum)		
Y5P	CGP(1)C681(2)HYD(3)A(4)	3,000	680 pF	±10% ±20%	8.5	6.5	5.0 mm 7.5 mm 10.0 mm 12.5 mm	
	CGP(1)C821(2)HYD(3)A(4)		820 pF					
	CGP(1)C102(2)HYD(3)A(4)		1000 pF					
	CGP(1)C122(2)HYD(3)A(4)		1200 pF					
	CGP(1)C152(2)HYD(3)A(4)		1500 pF					
	CGP(1)C182(2)HYD(3)A(4)		1800 pF					
	CGP(1)C222(2)HYD(3)A(4)		2200 pF					
	CGP(1)C272(2)HYD(3)A(4)		2700 pF					
	CGP(1)C332(2)HYD(3)A(4)		3300 pF					
	CGP(1)C392(2)HYD(3)A(4)		3900 pF					
	CGP(1)C472(2)HYD(3)A(4)	4700 pF	19.5		7.5 mm 10.0 mm 12.5 mm			
	CGP(1)C101(2)UYD(3)A(4)	4,000	100 pF		±10% ±20%	6.5	6.5	5.0 mm 7.5 mm 10.0 mm 12.5 mm
	CGP(1)C121(2)UYD(3)A(4)		120 pF					
	CGP(1)C151(2)UYD(3)A(4)		150 pF					
	CGP(1)C181(2)UYD(3)A(4)		180 pF					
	CGP(1)C221(2)UYD(3)A(4)		220 pF					
	CGP(1)C271(2)UYD(3)A(4)		270 pF					
	CGP(1)C331(2)UYD(3)A(4)		330 pF					
	CGP(1)C391(2)UYD(3)A(4)		390 pF					
	CGP(1)C471(2)UYD(3)A(4)		470 pF					
	CGP(1)C561(2)UYD(3)A(4)		560 pF					
	CGP(1)C681(2)UYD(3)A(4)		680 pF					
	CGP(1)C821(2)UYD(3)A(4)		820 pF					
	CGP(1)C102(2)UYD(3)A(4)		1000 pF					
	CGP(1)C122(2)UYD(3)A(4)		1200 pF					
	CGP(1)C152(2)UYD(3)A(4)		1500 pF					
	CGP(1)C182(2)UYD(3)A(4)		1800 pF					
	CGP(1)C222(2)UYD(3)A(4)		2200 pF					
	CGP(1)C272(2)UYD(3)A(4)		2700 pF					
	CGP(1)C332(2)UYD(3)A(4)		3300 pF					
	CGP(1)C392(2)UYD(3)A(4)		3900 pF					
	CGP(1)C472(2)UYD(3)A(4)	4700 pF	19.5		5.0 mm 7.5 mm 10.0 mm 12.5 mm			
	CGP(1)C101(2)KYD(3)A(4)	6,000	100 pF		±10% ±20%	9.5	8	7.5 mm 10.0 mm 12.5 mm
	CGP(1)C121(2)KYD(3)A(4)		120 pF					
	CGP(1)C151(2)KYD(3)A(4)		150 pF					
	CGP(1)C181(2)KYD(3)A(4)		180 pF					
	CGP(1)C221(2)KYD(3)A(4)		220 pF					
	CGP(1)C271(2)KYD(3)A(4)		270 pF					
	CGP(1)C331(2)KYD(3)A(4)		330 pF					
	CGP(1)C391(2)KYD(3)A(4)		390 pF					
	CGP(1)C471(2)KYD(3)A(4)		470 pF					
	CGP(1)C561(2)KYD(3)A(4)		560 pF					
	CGP(1)C681(2)KYD(3)A(4)		680 pF					
	CGP(1)C821(2)KYD(3)A(4)		820 pF					
	CGP(1)C102(2)KYD(3)A(4)		1000 pF					
CGP(1)C122(2)KYD(3)A(4)	1200 pF							
CGP(1)C152(2)KYD(3)A(4)	1500 pF		10.5	7.5 mm 10.0 mm 12.5 mm				
CGP(1)C182(2)KYD(3)A(4)	1800 pF							
CGP(1)C222(2)KYD(3)A(4)	2200 pF							
CGP(1)C272(2)KYD(3)A(4)	2700 pF							
CGP(1)C332(2)KYD(3)A(4)	3300 pF							
CGP(1)C392(2)KYD(3)A(4)	3900 pF							
CGP(1)C472(2)KYD(3)A(4)	4700 pF	16.5						

(1) To properly complete ordering code, insert the one-digit numeric code to reflect required lead spacing:

(Note that select capacitance values and packaging options may limit lead spacing availability. See table above to verify availability.)

5 = 5.0 mm 7 = 7.5 mm 1 = 10.0 mm 2 = 12.5 mm

(2) To properly complete ordering code, insert the one-digit character code to reflect the required capacitance tolerance:

K = ±10% M = ±20%

(3) To properly complete ordering code, insert the one-digit character code to reflect the required lead configuration: (See "Lead Configuration" section of this document, for further details.)

A = Straight B = Vertical Kink C = Outside Kink D = Inside Kink

(4) To properly complete ordering code, enter the four-digit numeric or alphanumeric "Packaging C-Spec Ordering Code." See "Dimensions" section of this document, for available options.

Radial Leaded Ceramic Disc Capacitors

General Purpose Disc, CGP Series, 1,000 - 10,000 VDC (Commercial Grade)

Table 1B – Product Ordering Codes and Ratings - Y5P Dielectric cont.

Dielectric/ Temp. Char.	KEMET Part Number	Rated Voltage (VDC)	Capacitance	Capacitance Tolerance	Dimensions (mm)		Lead Spacing	
					Body Diameter (Maximum)	Body Thickness (Maximum)		
Y5P	CGP(1)C101(2)LYD(3)A(4)	8,000	100 pF	±10% ±20%	10.0	9	10.0 mm 12.5 mm	
	CGP(1)C121(2)LYD(3)A(4)		120 pF					
	CGP(1)C151(2)LYD(3)A(4)		150 pF					
	CGP(1)C181(2)LYD(3)A(4)		180 pF					
	CGP(1)C221(2)LYD(3)A(4)		220 pF		11.0			
	CGP(1)C271(2)LYD(3)A(4)		270 pF					
	CGP(1)C331(2)LYD(3)A(4)		330 pF					
	CGP(1)C391(2)LYD(3)A(4)		390 pF					
	CGP(1)C471(2)LYD(3)A(4)		470 pF		11.5			
	CGP(1)C561(2)LYD(3)A(4)		560 pF		12.5			
	CGP(1)C681(2)LYD(3)A(4)		680 pF		13.0			
	CGP(1)C821(2)LYD(3)A(4)		820 pF		14.0			
	CGP(1)C102(2)LYD(3)A(4)		1000 pF		15.0			
	CGP(1)C122(2)LYD(3)A(4)		1200 pF		16.0			
	CGP(1)C152(2)LYD(3)A(4)		1500 pF		17.0			
	CGP(1)C101(2)NYD(3)A(4)	100 pF	19.0					
	CGP(1)C121(2)NYD(3)A(4)	120 pF	10,000	±10% ±20%	11.0	10		
	CGP(1)C151(2)NYD(3)A(4)	150 pF						
	CGP(1)C181(2)NYD(3)A(4)	180 pF						
	CGP(1)C221(2)NYD(3)A(4)	220 pF						
	CGP(1)C271(2)NYD(3)A(4)	270 pF			11.5			
	CGP(1)C331(2)NYD(3)A(4)	330 pF						
	CGP(1)C391(2)NYD(3)A(4)	390 pF						
	CGP(1)C471(2)NYD(3)A(4)	470 pF			13.0			
	CGP(1)C561(2)NYD(3)A(4)	560 pF			13.5			
	CGP(1)C681(2)NYD(3)A(4)	680 pF			14.5			
	CGP(1)C821(2)NYD(3)A(4)	820 pF			17.0			
	CGP(1)C102(2)NYD(3)A(4)	1000 pF						

(1) To properly complete ordering code, insert the one-digit numeric code to reflect required lead spacing:

(Note that select capacitance values and packaging options may limit lead spacing availability. See table above to verify availability.)

5 = 5.0 mm 7 = 7.5 mm 1 = 10.0 mm 2 = 12.5 mm

(2) To properly complete ordering code, insert the one-digit character code to reflect the required capacitance tolerance:

K = ±10% M = ±20%

(3) To properly complete ordering code, insert the one-digit character code to reflect the required lead configuration: (See "Lead Configuration" section of this document, for further details.)

A = Straight B = Vertical Kink C = Outside Kink D = Inside Kink

(4) To properly complete ordering code, enter the four-digit numeric or alphanumeric "Packaging C-Spec Ordering Code." See "Dimensions" section of this document, for available options.

Radial Leaded Ceramic Disc Capacitors

General Purpose Disc, CGP Series, 1,000 - 10,000 VDC (Commercial Grade)

Table 1C – Product Ordering Codes and Ratings - Y5U Dielectric

Dielectric/ Temp. Char.	KEMET Part Number	Rated Voltage (VDC)	Capacitance	Capacitance Tolerance	Dimensions (mm)		Lead Spacing
					Body Diameter (Maximum)	Body Thickness (Maximum)	
Y5U	CGP(1)C102(2)DWD(3)A(4)	1,000	1000 pF	±20%	5.5	4	5.0 mm 7.5 mm 10.0 mm 12.5 mm
	CGP(1)C152(2)DWD(3)A(4)		1500 pF		6.5		
	CGP(1)C222(2)DWD(3)A(4)		2200 pF		8.5		
	CGP(1)C332(2)DWD(3)A(4)		3300 pF		9.5		
	CGP(1)C472(2)DWD(3)A(4)		4700 pF		10.5		
	CGP(1)C562(2)DWD(3)A(4)		5600 pF		12.5		
	CGP(1)C682(2)DWD(3)A(4)		6800 pF		7.5		
	CGP(1)C103(2)DWD(3)A(4)		10000 pF		8.5		
	CGP(1)C102(2)GWD(3)A(4)	2,000	1000 pF		10.5	5	
	CGP(1)C152(2)GWD(3)A(4)		1500 pF		12.5		
	CGP(1)C222(2)GWD(3)A(4)		2200 pF		13.5		
	CGP(1)C332(2)GWD(3)A(4)		3300 pF		14.5		
	CGP(1)C472(2)GWD(3)A(4)		4700 pF		15.5		
	CGP(1)C562(2)GWD(3)A(4)		5600 pF		17.5		
	CGP(1)C682(2)GWD(3)A(4)		6800 pF		7.5		
	CGP(1)C103(2)GWD(3)A(4)		10000 pF		8.5		
	CGP(1)C102(2)HWD(3)A(4)	3,000	1000 pF		9.5	6.5	
	CGP(1)C152(2)HWD(3)A(4)		1500 pF		11.5		
	CGP(1)C222(2)HWD(3)A(4)		2200 pF		13.5		
	CGP(1)C332(2)HWD(3)A(4)		3300 pF		14.5		
	CGP(1)C472(2)HWD(3)A(4)		4700 pF		15.5		
	CGP(1)C562(2)HWD(3)A(4)		5600 pF		17.5		
	CGP(1)C682(2)HWD(3)A(4)		6800 pF		7.5		
	CGP(1)C103(2)HWD(3)A(4)		10000 pF		8.5		
	CGP(1)C102(2)UWD(3)A(4)	4,000	1000 pF		9.5	8	
	CGP(1)C152(2)UWD(3)A(4)		1500 pF		11.5		
	CGP(1)C222(2)UWD(3)A(4)		2200 pF		13.5		
	CGP(1)C332(2)UWD(3)A(4)		3300 pF		14.5		
	CGP(1)C472(2)UWD(3)A(4)		4700 pF		15.5		
	CGP(1)C562(2)UWD(3)A(4)		5600 pF		17.5		
	CGP(1)C682(2)UWD(3)A(4)		6800 pF		10.0		
	CGP(1)C103(2)UWD(3)A(4)		10000 pF		11.5		
	CGP(1)C102(2)KWD(3)A(4)	6,000	1000 pF		13.0	9	
	CGP(1)C152(2)KWD(3)A(4)		1500 pF		15.5		
	CGP(1)C222(2)KWD(3)A(4)		2200 pF		16.0		
	CGP(1)C332(2)KWD(3)A(4)		3300 pF		19.0		
	CGP(1)C472(2)KWD(3)A(4)		4700 pF		20.5		
	CGP(1)C562(2)KWD(3)A(4)		5600 pF		11.5		
	CGP(1)C682(2)KWD(3)A(4)		6800 pF		13.5		
	CGP(1)C102(2)LWD(3)A(4)		1000 pF		15.5		
CGP(1)C102(2)LWD(3)A(4)	8,000	1000 pF	17.5	10			
CGP(1)C152(2)LWD(3)A(4)		1500 pF	21.0				
CGP(1)C222(2)LWD(3)A(4)		2200 pF	12.5				
CGP(1)C332(2)LWD(3)A(4)		3300 pF	14.5				
CGP(1)C472(2)LWD(3)A(4)		4700 pF	17.0				
CGP(1)C562(2)LWD(3)A(4)		5600 pF	19.0				
CGP(1)C682(2)LWD(3)A(4)		6800 pF	22.5				
CGP(1)C102(2)NWD(3)A(4)		1000 pF	25.5				
CGP(1)C152(2)NWD(3)A(4)	10,000	1500 pF					
CGP(1)C222(2)NWD(3)A(4)		2200 pF					
CGP(1)C332(2)NWD(3)A(4)		3300 pF					
CGP(1)C472(2)NWD(3)A(4)		4700 pF					
CGP(1)C562(2)NWD(3)A(4)		5600 pF					
CGP(1)C682(2)NWD(3)A(4)		6800 pF					
CGP(1)C102(2)NWD(3)A(4)		1000 pF					
CGP(1)C152(2)NWD(3)A(4)		1500 pF					

(1) To properly complete ordering code, insert the one-digit numeric code to reflect required lead spacing:
 (Note that select capacitance values and packaging options may limit lead spacing availability. See table above to verify availability.)
 5 = 5.0 mm 7 = 7.5 mm 1 = 10.0 mm 2 = 12.5 mm

(2) To properly complete ordering code, insert the one-digit character code to reflect the required capacitance tolerance:
 M = ±20%

(3) To properly complete ordering code, insert the one-digit character code to reflect the required lead configuration: (See "Lead Configuration" section of this document, for further details.)

A = Straight B = Vertical Kink C = Outside Kink D = Inside Kink

(4) To properly complete ordering code, enter the four-digit numeric or alphanumeric "Packaging C-Spec Ordering Code." See "Dimensions" section of this document, for available options.

Radial Leaded Ceramic Disc Capacitors

General Purpose Disc, CGP Series, 1,000 - 10,000 VDC (Commercial Grade)

Table 1D – Product Ordering Codes and Ratings - Y5V Dielectric

Dielectric/ Temp. Char.	KEMET Part Number	Rated Voltage (VDC)	Capacitance	Capacitance Tolerance	Dimensions (mm)		Lead Spacing
					Body Diameter (Maximum)	Body Thickness (Maximum)	
Y5V	CGP(1)C102(2)DVD(3)A(4)	1,000	1000 pF	±20%	5.5	4	5.0 mm 7.5 mm 10.0 mm 12.5 mm
	CGP(1)C152(2)DVD(3)A(4)		1500 pF		6.5		
	CGP(1)C222(2)DVD(3)A(4)		2200 pF				
	CGP(1)C332(2)DVD(3)A(4)		3300 pF				
	CGP(1)C472(2)DVD(3)A(4)		4700 pF				
	CGP(1)C562(2)DVD(3)A(4)		5600 pF				
	CGP(1)C682(2)DVD(3)A(4)		6800 pF				
	CGP(1)C103(2)DVD(3)A(4)		10000 pF				
	CGP(1)C102(2)GVD(3)A(4)	2,000	1000 pF		6.5	5	
	CGP(1)C152(2)GVD(3)A(4)		1500 pF				
	CGP(1)C222(2)GVD(3)A(4)		2200 pF				
	CGP(1)C332(2)GVD(3)A(4)		3300 pF				
	CGP(1)C472(2)GVD(3)A(4)		4700 pF				
	CGP(1)C562(2)GVD(3)A(4)		5600 pF				
	CGP(1)C682(2)GVD(3)A(4)		6800 pF				
	CGP(1)C103(2)GVD(3)A(4)		10000 pF				
	CGP(1)C102(2)HVD(3)A(4)	3,000	1000 pF		6.5	6.5	
	CGP(1)C152(2)HVD(3)A(4)		1500 pF				
	CGP(1)C222(2)HVD(3)A(4)		2200 pF				
	CGP(1)C332(2)HVD(3)A(4)		3300 pF				
	CGP(1)C472(2)HVD(3)A(4)		4700 pF				
	CGP(1)C562(2)HVD(3)A(4)		5600 pF				
	CGP(1)C682(2)HVD(3)A(4)		6800 pF				
	CGP(1)C103(2)HVD(3)A(4)		10000 pF				
	CGP(1)C102(2)UVD(3)A(4)	4,000	1000 pF		6.5	6.5	
	CGP(1)C152(2)UVD(3)A(4)		1500 pF				
	CGP(1)C222(2)UVD(3)A(4)		2200 pF				
	CGP(1)C332(2)UVD(3)A(4)		3300 pF				
	CGP(1)C472(2)UVD(3)A(4)		4700 pF				
	CGP(1)C562(2)UVD(3)A(4)		5600 pF				
	CGP(1)C682(2)UVD(3)A(4)		6800 pF				
	CGP(1)C103(2)UVD(3)A(4)		10000 pF				
	CGP(1)C102(2)KVD(3)A(4)	6,000	1000 pF		6.5	8	
	CGP(1)C152(2)KVD(3)A(4)		1500 pF				
	CGP(1)C222(2)KVD(3)A(4)		2200 pF				
	CGP(1)C332(2)KVD(3)A(4)		3300 pF				
	CGP(1)C472(2)KVD(3)A(4)		4700 pF				
	CGP(1)C562(2)KVD(3)A(4)		5600 pF				
	CGP(1)C682(2)KVD(3)A(4)		6800 pF				
	CGP(1)C102(2)LVD(3)A(4)		1000 pF				
	CGP(1)C152(2)LVD(3)A(4)	8,000	1500 pF		6.5	9	
	CGP(1)C222(2)LVD(3)A(4)		2200 pF				
	CGP(1)C332(2)LVD(3)A(4)		3300 pF				
	CGP(1)C472(2)LVD(3)A(4)		4700 pF				
	CGP(1)C562(2)LVD(3)A(4)		5600 pF				
	CGP(1)C682(2)LVD(3)A(4)		6800 pF				
	CGP(1)C102(2)NVD(3)A(4)		1000 pF				
	CGP(1)C152(2)NVD(3)A(4)		1500 pF				
CGP(1)C222(2)NVD(3)A(4)	10,000	2200 pF	6.5	10			
CGP(1)C332(2)NVD(3)A(4)		3300 pF					
CGP(1)C472(2)NVD(3)A(4)		4700 pF					
CGP(1)C102(2)NVD(3)A(4)		1000 pF					

(1) To properly complete ordering code, insert the one-digit numeric code to reflect required lead spacing:
 (Note that select capacitance values and packaging options may limit lead spacing availability. See table above to verify availability.)
 5 = 5.0 mm 7 = 7.5 mm 1 = 10.0 mm 2 = 12.5 mm

(2) To properly complete ordering code, insert the one-digit character code to reflect the required capacitance tolerance:
 M = ±20%

(3) To properly complete ordering code, insert the one-digit character code to reflect the required lead configuration: (See "Lead Configuration" section of this document, for further details.)

A = Straight B = Vertical Kink C = Outside Kink D = Inside Kink

(4) To properly complete ordering code, enter the four-digit numeric or alphanumeric "Packaging C-Spec Ordering Code." See "Dimensions" section of this document, for available options.

Soldering and Mounting Information

Soldering:

When soldering this product to a PCB/PWB, do not exceed the solder heat resistance specification of the capacitor. Subjecting this product to excessive heating could reflow the solder joint between the lead and ceramic element and/or may result in thermal shocks that can crack the ceramic element.

When soldering these capacitors with a soldering iron, it should be performed under the following conditions:

- Temperature of iron-tip: 400°C maximum
- Soldering iron wattage: 50 W maximum
- Soldering time: 3.5 seconds maximum

Cleaning (ultrasonic cleaning):

To perform ultrasonic cleaning, observe the following conditions:

- Rinse bath capacity: output of 20 watts per liter or less
- Rinsing time: 5 minute maximum
- Do not vibrate the PCB/PWB directly
- Excessive ultrasonic cleaning may lead to fatigue destruction of the lead wires

Construction

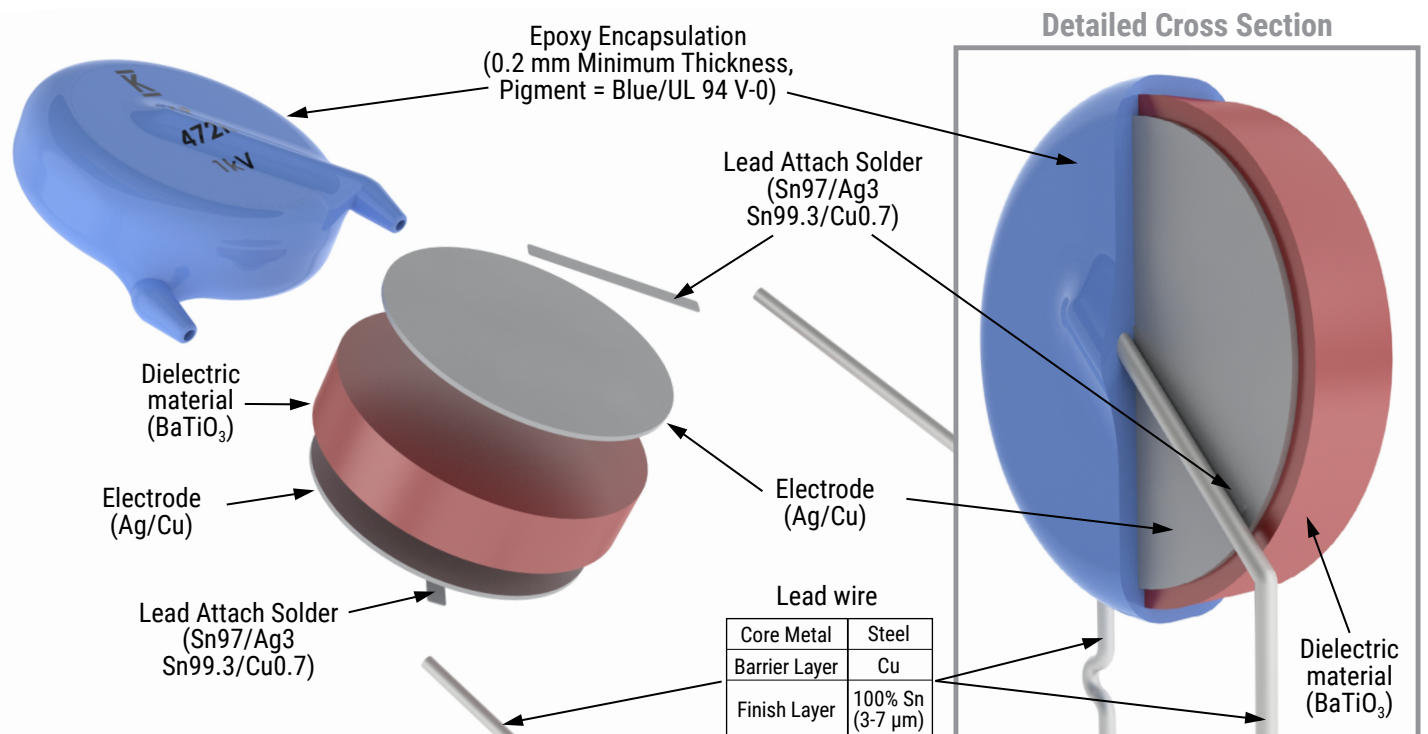

Radial Leaded Ceramic Disc Capacitors

General Purpose Disc, CGP Series, 1,000 - 10,000 VDC (Commercial Grade)

Marking

These capacitors shall be laser marked with KEMET's trademark, type designation, capacitor class, rated voltage, rated capacitance, and capacitance tolerance codes. In addition, all devices are marked with the recognized approval mark and a date/lot code for traceability. Marking will be supplied on one side of the encapsulated capacitor body. All marking shall be legible to allow for clear identification of the component. Marking appears in legible contrast. Illustrated below is an example of the marking format and content.

Note: KEMET has changed the part number ID in 2023 along with the marking (From KHB and KHC to SL, Y5P, Y5U and Y5V). No changes to materials, processes or testing has been done, just changes to marking and part number ID format. Customers might receive material with KHA, KHB, or KHC depending on the date code.

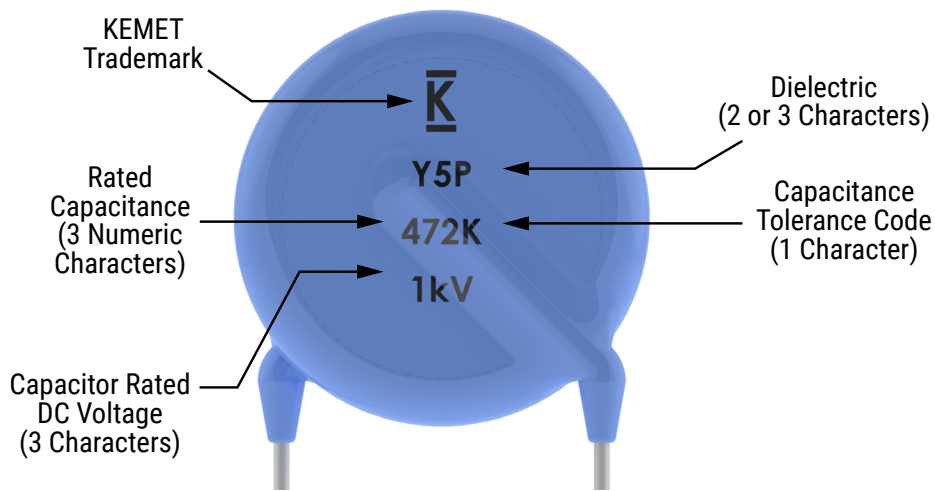

Radial Leaded Ceramic Disc Capacitors

General Purpose Disc, CGP Series, 1,000 - 10,000 VDC (Commercial Grade)

Packaging Quantities

Capacitor Body Diameter (mm)	Bulk Bag (Loose)	
	Lead Length (WL25)	Cut Lead Length (WL35, WL50, WL10)
All diameters options available	200 pieces/bag	500 pieces/bag

1kV and 2kV

Lead Spacing	Body Diameter (mm)	Pitch (Carrier Tape)	Reel (7301)	Ammo Pack (7317)
All the lead spacing options	≤ 8.0	12.7	2,000 pieces/reel	2,000 pieces/box
	$9.0 \leq D \leq 17.0$	25.4	1,500 pieces/reel	1,500 pieces/box

3 kV to 6 kV

Lead Spacing	Body Diameter (mm)	Pitch (Carrier Tape)	Reel (7301)	Ammo Pack (7317)
5	≤ 12.0	12.7	2,000 pieces/reel	1,000 pieces/box
	$12.0 < D \leq 22.5$	25.4	1,000 pieces/reel	750 pieces/box
7.5	≤ 12.0	12.7	2,000 pieces/reel	1,000 pieces/box
	$12.0 < D \leq 15.0$	25.4	1,000 pieces/reel	750 pieces/box
	≥ 16.0		750 pieces/reel	750 pieces/box
10	≤ 10	25.4	1,000 pieces/reel	1,000 pieces/box
	≥ 11		750 pieces/reel	750 pieces/box
12.5	≤ 9	25.4	1,000 pieces/reel	500 pieces/box
	≥ 10		500 pieces/reel	500 pieces/box

Figure 1 - Ammo/Reel Pack Taping Format

5 mm and 7.5 mm Lead Spacing:

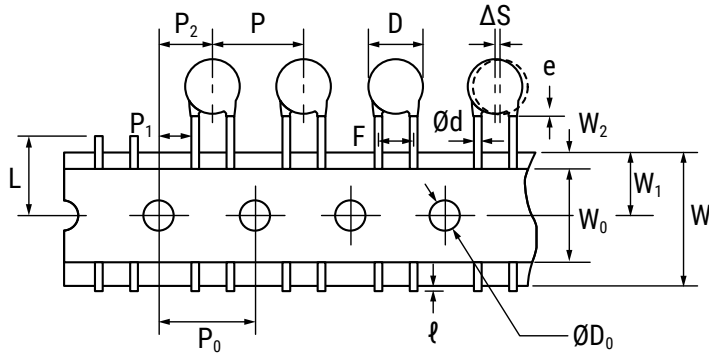

For All Lead Spacing:

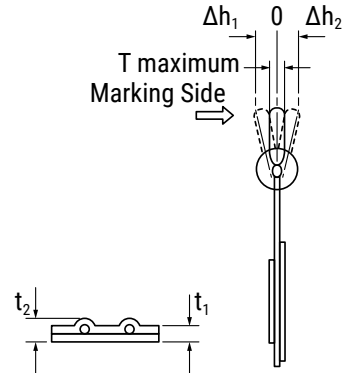

5 mm, 7.5 mm, 10 mm and 12.5 mm Lead Spacing:

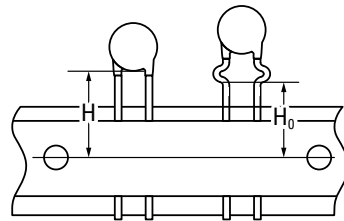
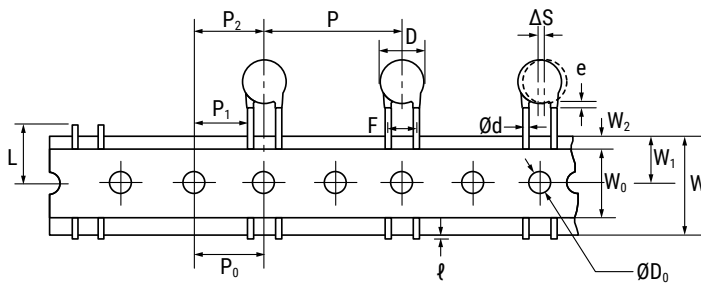

Table 3 – Ammo/Reel Pack Taping Specifications

Lead Spacing		5 mm				7.5 mm				10 mm		12.5 mm	
Lead Style		Straight		Preformed ¹		Straight		Preformed ¹		Straight	Preformed ¹	Straight	Preformed ¹
Item	Symbol	Dimensions (mm)											
Lead Spacing	F	5.0 ±1.0				7.5 ±1.0				10.0 ±1.0		12.5 ±1.0	
Component Pitch	P	12.7 ±1.0	25.4 ±2.0	12.7 ±1.0	25.4 ±2.0	12.7 ±1.0	25.4 ±2.0	12.7 ±1.0	25.4 ±2.0	25.4 ±2.0		25.4 ±2.0	
Sprocket Hole Pitch	P ₀	12.7 ±0.3				12.7 ±0.3				12.7 ±0.3		12.7 ±0.3	
Sprocket Hole Center to Component Center	P ₂	6.35 ±1.5	12.7 ±1.5	6.35 ±1.5	12.7 ±1.5	6.35 ±1.5	12.7 ±1.5	6.35 ±1.5	12.7 ±1.5	12.7 ±1.5		12.7 ±1.5	
Sprocket Hole Center to Lead Center	P ₁	3.85 ±0.7	10.2 ±1.5	3.85 ±0.7	10.2 ±1.5	2.6 ±0.7	8.95 ±1.5	2.6 ±0.7	8.95 ±1.5	7.7 ±1.5		6.45 ±1.5	
Body Diameter	D	See "Product Ordering Codes and Ratings" section of this document.											
Component Alignment (side/side)	ΔS	0 ±2.0											
Carrier Tape Width	W	18.0 +1.0/-0.5											
Sprocket Hole Position	W ₁	9.0 ±0.5											

¹ Preformed (crimped) lead configurations include vertical kink, outside kink, and inside kink. See "Lead Configurations" and "Ordering Information" sections of this document for further details.

² Also referred to as "lead length" in this document.

Table 3 – Ammo Pack Taping Specifications cont.

Lead Spacing		5 mm		7.5 mm		10 mm		12.5 mm	
Lead Style		Straight	Preformed ¹	Straight	Preformed ¹	Straight	Preformed ¹	Straight	Preformed ¹
Item	Symbol	Dimensions (mm)							
Height to Seating Plane ² (preformed leads ¹)	H ₀	N/A	16.0 +2.0/-0	N/A	16.0 +2.0/-0	N/A	16.0 +2.0/-0	N/A	16.0 +2.0/-0
Height to Seating Plane ² (straight leads)	H	20.0 +1.5/-1.0	N/A	20.0 +1.5/-1.0	N/A	20.0 +1.5/-1.0	N/A	20.0 +1.5/-1.0	N/A
Lead Protrusion	ℓ	2.0 maximum							
Diameter of Sprocket Hole	D ₀	4.0 ±0.2							
Lead Diameter	φd	0.6 ±0.1							
Carrier Tape Thickness	t ₁	0.6 ±0.3							
Total Thickness (Carrier Tape, Hold-Down Tape and Lead)	t ₂	1.5 maximum							
Component Alignment (front/back)	Δh ₁	2.0 maximum							
	Δh ₂								
Cut Out Length	L	11.0 maximum							
Hold-Down Tape Width	W ₀	10.0 minimum							
Hold-Down Tape Position	W ₂	3.0 maximum							
Coating Extension on Leads (meniscus)	e	3.0 maximum for straight lead; not to exceed the bend for preformed ¹ lead configurations.							
Body Thickness	T	8.0 maximum							

¹ Preformed (crimped) lead configurations include vertical kink, outside kink, and inside kink. See "Lead Configurations" and "Ordering Information" sections of this document for further details.

² Also referred to as "lead length" in this document.

Application Notes:

Storage and Operating Conditions:

The Insulating coating of these devices does not form an air and moisture tight seal. Avoid exposure to moisture and do not use or store these devices in a corrosive atmosphere, especially where chloride gas, sulfide gas, acid, alkali, salt or the like are present. Before cleaning, bonding or molding these devices, it is important to verify that your process does not affect product quality and performance. KEMET recommends testing and evaluating the performance of a cleaned, bonded or molded product prior to implementing and/or qualifying any of these processes. Store the capacitors where the temperature and relative humidity do not exceed 40 degrees centigrade and 70% respectively. For optimum solderability, capacitor stock should be used promptly, preferably within 6 months of receipt.

Working Voltage:

Application voltage (V_{p-p} or V_{o-p}) must not exceed the voltage rating of the capacitor. Irregular voltages can be generated for a transient period of time when voltage is initially applied and/or removed from a circuit. It is important to choose a capacitor with a voltage rating greater than or equal to these irregular voltages.

Radial Leaded Ceramic Disc Capacitors

General Purpose Disc, CGP Series, 1,000 - 10,000 VDC (Commercial Grade)

Application Notes (cont.):

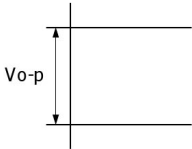
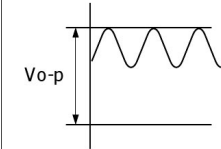
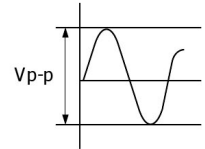
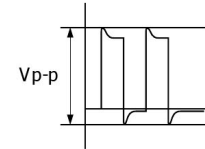
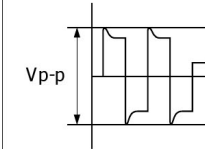
Voltage	DC Voltage	DC+AC Voltage	AC Voltage	Pulse Voltage (1)	Pulse Voltage (2)
Positional Measurement					

Operating Temperature and Self-Generating Heat:

The surface temperature of a capacitor should be kept below the upper limit of its rated operating temperature range. Be sure to take into account the heat generated by the capacitor itself. When the capacitor is used in a high-frequency current, pulse current or similar current, it may self-generate heat due to dielectric loss. Temperature rise due to self-generated heating should not exceed 20°C (while operated at an atmosphere temperature of 25°C).

Handling - Vibration and Impact:

Do not expose these devices or their leads to excessive shock or vibration during use.

FAILURE TO FOLLOW THE ABOVE CAUTIONS MAY RESULT, WORST CASE, IN A SHORT CIRCUIT AND CAUSE FUMING OR PARTIAL DISPERSION WHEN THE PRODUCT IS USED.

KEMET Electronics Corporation Sales Offices

For a complete list of our global sales offices, please visit <https://www.yageogroup.com/SalesResources/SalesOffices>

Disclaimer

YAGEO Corporation and its affiliates do not recommend the use of commercial or automotive grade products for high reliability applications or manned space flight.

All product specifications, statements, information and data (collectively, the "Information") in this datasheet are subject to change. The customer is responsible for checking and verifying the extent to which the Information contained in this publication is applicable to an order at the time the order is placed. All Information given herein is believed to be accurate and reliable, but it is presented without guarantee, warranty, or responsibility of any kind, expressed or implied.

Statements of suitability for certain applications are based on KEMET Electronics Corporation's ("KEMET") knowledge of typical operating conditions for such applications, but are not intended to constitute – and KEMET specifically disclaims – any warranty concerning suitability for a specific customer application or use. The Information is intended for use only by customers who have the requisite experience and capability to determine the correct products for their application. Any technical advice inferred from this Information or otherwise provided by KEMET with reference to the use of KEMET's products is given gratis, and KEMET assumes no obligation or liability for the advice given or results obtained.

Although KEMET designs and manufactures its products to the most stringent quality and safety standards, given the current state of the art, isolated component failures may still occur. Accordingly, customer applications which require a high degree of reliability or safety should employ suitable designs or other safeguards (such as installation of protective circuitry or redundancies) in order to ensure that the failure of an electrical component does not result in a risk of personal injury or property damage.

Although all product-related warnings, cautions and notes must be observed, the customer should not assume that all safety measures are indicated or that other measures may not be required.

KEMET is a registered trademark of KEMET Electronics Corporation.