

# ON Semiconductor

## Is Now

# onsemi™

To learn more about onsemi™, please visit our website at  
[www.onsemi.com](http://www.onsemi.com)

**onsemi** and **onsemi** and other names, marks, and brands are registered and/or common law trademarks of Semiconductor Components Industries, LLC dba "**onsemi**" or its affiliates and/or subsidiaries in the United States and/or other countries. **onsemi** owns the rights to a number of patents, trademarks, copyrights, trade secrets, and other intellectual property. A listing of **onsemi** product/patent coverage may be accessed at [www.onsemi.com/site/pdf/Patent-Marking.pdf](http://www.onsemi.com/site/pdf/Patent-Marking.pdf). **onsemi** reserves the right to make changes at any time to any products or information herein, without notice. The information herein is provided "as-is" and **onsemi** makes no warranty, representation or guarantee regarding the accuracy of the information, product features, availability, functionality, or suitability of its products for any particular purpose, nor does **onsemi** assume any liability arising out of the application or use of any product or circuit, and specifically disclaims any and all liability, including without limitation special, consequential or incidental damages. Buyer is responsible for its products and applications using **onsemi** products, including compliance with all laws, regulations and safety requirements or standards, regardless of any support or applications information provided by **onsemi**. "Typical" parameters which may be provided in **onsemi** data sheets and/or specifications can and do vary in different applications and actual performance may vary over time. All operating parameters, including "Typicals" must be validated for each customer application by customer's technical experts. **onsemi** does not convey any license under any of its intellectual property rights nor the rights of others. **onsemi** products are not designed, intended, or authorized for use as a critical component in life support systems or any FDA Class 3 medical devices or medical devices with a same or similar classification in a foreign jurisdiction or any devices intended for implantation in the human body. Should Buyer purchase or use **onsemi** products for any such unintended or unauthorized application, Buyer shall indemnify and hold **onsemi** and its officers, employees, subsidiaries, affiliates, and distributors harmless against all claims, costs, damages, and expenses, and reasonable attorney fees arising out of, directly or indirectly, any claim of personal injury or death associated with such unintended or unauthorized use, even if such claim alleges that **onsemi** was negligent regarding the design or manufacture of the part. **onsemi** is an Equal Opportunity/Affirmative Action Employer. This literature is subject to all applicable copyright laws and is not for resale in any manner. Other names and brands may be claimed as the property of others.

# STK541UC62K-E

## Intelligent Power Module (IPM) 600 V, 10 A



ON Semiconductor®

www.onsemi.com

### Overview

This “Inverter IPM” is highly integrated device containing all High Voltage (HV) control from HV-DC to 3-phase outputs in a single SIP module (Single-In line Package). Output stage uses IGBT/FRD technology and implements Under Voltage Protection (UVP) and Over Current Protection (OCP) with a Fault Detection output flag. Internal Boost diodes are provided for high side gate boost drive.

### Function

- Single control power supply due to Internal bootstrap circuit for high side pre-driver circuit
- All control input and status output are at low voltage levels directly compatible with microcontrollers
- Built-in cross conduction prevention
- Externally accessible embedded thermistor for substrate temperature measurement

### Certification

- UL1557 (File Number : E339285)

### Specifications

#### Absolute Maximum Ratings at Tc = 25°C

Parameter	Symbol	Conditions	Ratings	Unit
Supply voltage	V <sub>CC</sub>	P to N, surge < 500 V *1	450	V
Collector-emitter voltage	V <sub>CE</sub>	P to U, V, W or U, V, W to N	600	V
Output current	I <sub>o</sub>	P, N, U, V, W terminal current	±10	A
		P, N, U, V, W terminal current at Tc = 100°C	±5	A
Output peak current	I <sub>op</sub>	P, N, U, V, W terminal current for a Pulse width of 1 ms.	±20	A
Pre-driver voltage	VD1, 2, 3, 4	VB1 to U, VB2 to V, VB3 to W, V <sub>DD</sub> to V <sub>SS</sub> *2	20	V
Input signal voltage	V <sub>IN</sub>	HIN1, 2, 3, LIN1, 2, 3	-0.3 to 7	V
FLTEN terminal voltage	V <sub>FLTEN</sub>	FLTEN terminal	-0.3 to V <sub>DD</sub>	V
Maximum power dissipation	P <sub>d</sub>	IGBT per channel	22	W
Junction temperature	T <sub>j</sub>	IGBT, FRD	150	°C
Storage temperature	T <sub>stg</sub>		-40 to +125	°C
Operating substrate temperature	T <sub>c</sub>	IPM case temperature	-40 to +100	°C
Tightening torque		Case mounting screws *3	0.9	Nm
Isolation voltage	V <sub>is</sub>	50 Hz sine wave AC 1 minute *4	2000	VRMS

Reference voltage is “V<sub>SS</sub>” terminal voltage unless otherwise specified.

\*1 : Surge voltage developed by the switching operation due to the wiring inductance between “P” and “N” terminal.

\*2 : Terminal voltage: VD1 = VB1 to U, VD2 = VB2 to V, VD3 = VB3 to W, VD4 = V<sub>DD</sub> to V<sub>SS</sub>

\*3 : Flatness of the heat-sink should be 0.15 mm and below.

\*4 : Test conditions : AC 2500 V, 1 s.

Stresses exceeding those listed in the Maximum Ratings table may damage the device. If any of these limits are exceeded, device functionality should not be assumed, damage may occur and reliability may be affected.

### ORDERING INFORMATION

See detailed ordering and shipping information on page 14 of this data sheet.

## STK541UC62K-E

**Electrical Characteristics** at  $T_c = 25^\circ\text{C}$ , VD1, VD2, VD3, VD4 = 15 V

Parameter	Symbol	Conditions	Test circuit	min	typ	max	Unit	
<b>Power output section</b>								
Collector-emitter cut-off current	$I_{CE}$	$V_{CE} = 600\text{ V}$	Fig.1	–	–	0.1	mA	
Bootstrap diode reverse current	$I_{R(BD)}$	$V_{R(BD)}$		–	–	0.1	mA	
Collector to emitter saturation voltage	$V_{CE(sat)}$	$I_c = 10\text{ A}$ $T_j = 25^\circ\text{C}$	Upper side	Fig.2	–	1.4	2.3	V
			Lower side *1		–	1.7	2.6	
		$I_c = 5\text{ A}$ $T_j = 100^\circ\text{C}$	Upper side		–	1.3	–	
			Lower side *1		–	1.6	–	
Diode forward voltage	VF	$I_F = 10\text{ A}$ $T_j = 25^\circ\text{C}$	Upper side	Fig.3	–	1.3	2.2	V
			Lower side *1		–	1.6	2.5	
		$I_F = 5\text{ A}$ $T_j = 100^\circ\text{C}$	Upper side		–	1.2	–	
			Lower side *1		–	1.5	–	
Junction to case thermal resistance	$\theta_{j-c(T)}$	IGBT		–	–	5.5	$^\circ\text{C/W}$	
	$\theta_{j-c(D)}$	FRD		–	–	6.5		
<b>Control (Pre-driver) section</b>								
Pre-driver current consumption	ID	VD1, 2, 3 = 15 V	Fig.4	–	0.08	0.4	mA	
		VD4 = 15 V		–	1.6	4.0		
High level Input voltage	$V_{in H}$	HIN1, HIN2, HIN3, LIN1, LIN2, LIN3 to $V_{SS}$		2.5	–	–	V	
Low level Input voltage	$V_{in L}$			–	–	0.8	V	
Input threshold voltage hysteresis *1	$V_{inH(hys)}$			0.5	0.8	–	V	
Logic 0 input leakage current	$I_{IN+}$	$V_{IN} = +3.3\text{ V}$		76	118	160	$\mu\text{A}$	
Logic 1 input leakage current	$I_{IN-}$	$V_{IN} = 0\text{ V}$		97	150	203	$\mu\text{A}$	
FLTEN terminal input electric current	$I_{oSD}$	FAULT : ON/VFLTEN = 0.1 V		–	2	–	mA	
FAULT clearance delay time	FLTCLR	Fault output latch time		6	9	12	ms	
FLTEN Threshold	$V_{EN+}$	Enable		2.5	–	–	V	
	$V_{EN-}$	Disable		–	–	0.8		
$V_{CC}$ and $V_S$ undervoltage upper threshold	$V_{CCUV+}$ $V_{SUV+}$			10.5	11.1	11.7	V	
$V_{CC}$ and $V_S$ undervoltage lower threshold	$V_{CCUV-}$ $V_{SUV-}$			10.3	10.9	11.5	V	
$V_{CC}$ and $V_S$ undervoltage hysteresis	$V_{CCUVH}$ $V_{SUVH-}$			0.14	0.2	–	A	
Over current protection level	ISD	$PW = 100\ \mu\text{s}$	Fig.5	10	–	17	A	
Output level for current monitor	ISO	$I_o = 10\text{ A}$		0.30	0.33	0.36	V	

Reference voltage is " $V_{SS}$ " terminal voltage unless otherwise specified.

\*1 : The lower side's  $V_{CE(sat)}$  and VF include a loss by the shunt resistance

**Electrical Characteristics** at  $T_c = 25^\circ\text{C}$ , VD1, VD2, VD3, VD4 = 15 V,  $V_{CC} = 300\text{ V}$ ,  $L = 3.9\text{ mH}$

Parameter	Symbol	Conditions	Test circuit	min	typ	max	Unit
<b>Switching Character</b>							
Switching time	$t_{ON}$	$I_o = 10\text{ A}$ Inductive load	Fig.6	0.2	0.4	1.1	$\mu\text{s}$
	$t_{OFF}$			–	0.5	1.2	
Turn-on switching loss	$E_{on}$	$I_c = 5\text{ A}$ , $P = 300\text{ V}$ , $V_{DD} = 15\text{ V}$ , $L = 3.9\text{ mH}$ $T_c = 25^\circ\text{C}$	Fig.6	–	200	–	$\mu\text{J}$
Turn-off switching loss	$E_{off}$			–	130	–	$\mu\text{J}$
Total switching loss	$E_{tot}$			–	330	–	$\mu\text{J}$
Turn-on switching loss	$E_{on}$	$I_c = 5\text{ A}$ , $P = 300\text{ V}$ , $V_{DD} = 15\text{ V}$ , $L = 3.9\text{ mH}$ $T_c = 100^\circ\text{C}$	Fig.6	–	240	–	$\mu\text{J}$
Turn-off switching loss	$E_{off}$			–	160	–	$\mu\text{J}$
Total switching loss	$E_{tot}$			–	400	–	$\mu\text{J}$
Diode reverse recovery energy	$E_{rec}$	$I_F = 5\text{ A}$ , $P = 400\text{ V}$ , $V_{DD} = 15\text{ V}$ , $L = 0.5\text{ mH}$ , $T_c = 100^\circ\text{C}$		–	17	–	$\mu\text{J}$
Diode reverse recovery time	$T_{rr}$		–	62	–	ns	
Reverse bias safe operating area	RBSOA	$I_o = 20\text{ A}$ , $V_{CE} = 450\text{ V}$		Full square			
Short circuit safe operating area	SCSOA	$V_{CE} = 400\text{ V}$ , $T_c = 100^\circ\text{C}$		4	–	–	$\mu\text{s}$

Reference voltage is " $V_{SS}$ " terminal voltage unless otherwise specified.

Product parametric performance is indicated in the Electrical Characteristics for the listed test conditions, unless otherwise noted. Product performance may not be indicated by the Electrical Characteristics if operated under different conditions.

**Notes :**

- The pre-drive power supply low voltage protection has approximately 0.2 V of hysteresis and operates as follows.  
 Upper side : The gate is turned off and will return to regular operation when recovering to the normal voltage, but the latch will continue till the input signal will turn 'high'.  
 Lower side : The gate is turned off and will automatically reset when recovering to normal voltage. It does not depend on input signal voltage.
- The pre-drive low voltage protection is the feature to protect devices when the pre-driver supply voltage falls due to an operating malfunction.

# STK541UC62K-E

## Equivalent Block Diagram

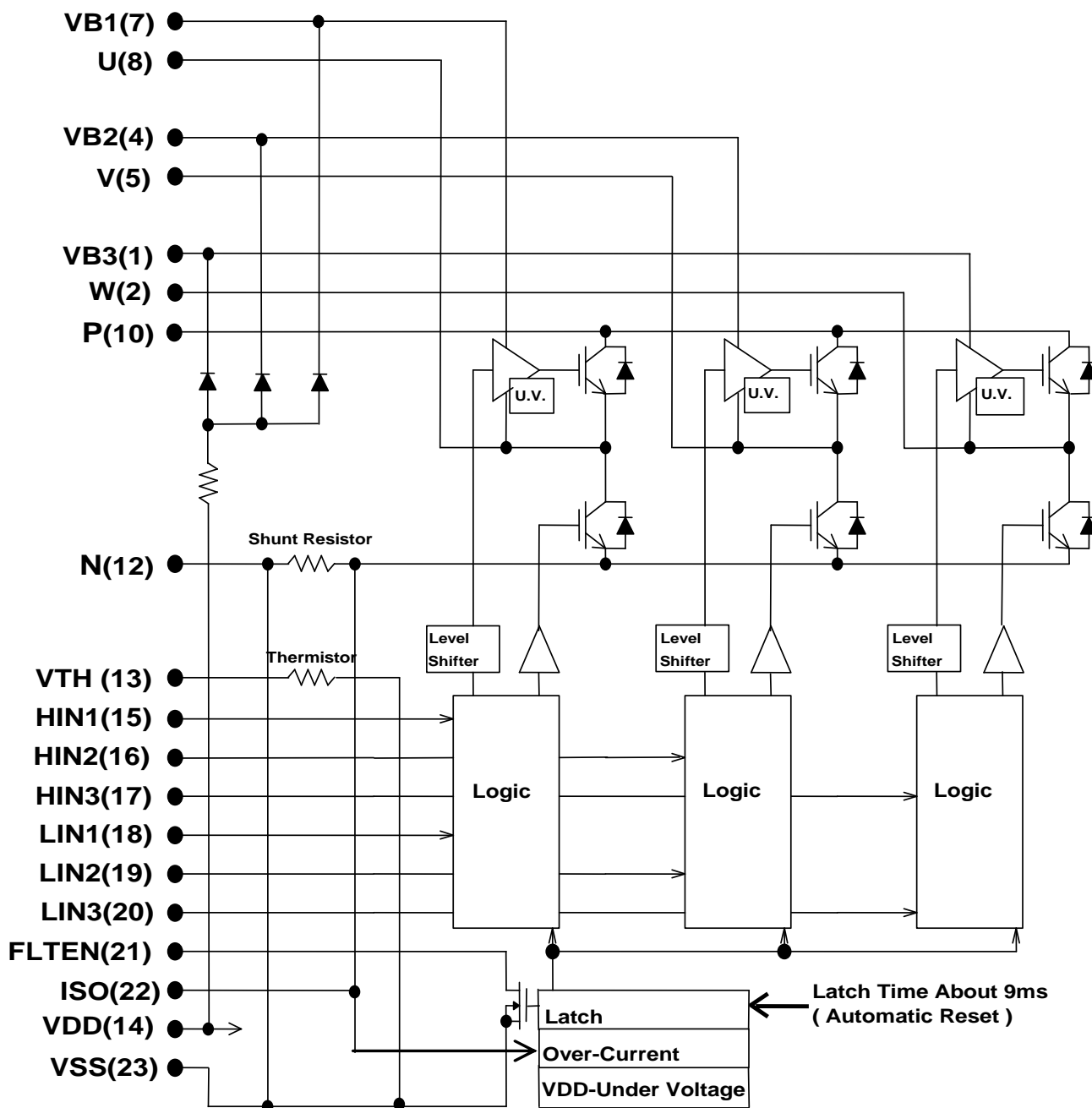

# STK541UC62K-E

## Module Pin-Out Description

Pin	Name	Description
1	VB3	High Side Floating Supply Voltage 3
2	W, VS3	Output 3 - High Side Floating Supply Offset Voltage
3	-	Witout Pin
4	VB2	High Side Floating Supply voltage 2
5	V,VS2	Output 2 - High Side Floating Supply Offset Voltage
6	-	Witout Pin
7	VB1	High Side Floating Supply voltage 1
8	U,VS1	Output 1 - High Side Floating Supply Offset Voltage
9	-	Witout Pin
10	P	Positive Bus Input Voltage
11	-	Witout Pin
12	N	Negative Bus Input Voltage
13	VTH	Temperature Feedback
14	VDD	+15 V Main Supply
15	HIN1	Logic Input High Side Gate Driver - Phase U
16	HIN2	Logic Input High Side Gate Driver - Phase V
17	HIN3	Logic Input High Side Gate Driver - Phase W
18	LIN1	Logic Input Low Side Gate Driver - Phase U
19	LIN2	Logic Input Low Side Gate Driver - Phase V
20	LIN3	Logic Input Low Side Gate Driver - Phase W
21	FLTEN	Fault output and Enable
22	ISO	Current monitor output
23	VSS	Negative Main Supply

# STK541UC62K-E

## Test Circuit

The tested phase U+ shows the upper side of the U phase and U- shows the lower side of the U phase.

### ■ ICE / IR(BD)

	U+	V+	W+	U-	V-	W-
M	10	10	10	8	5	2
N	8	5	2	12	12	12

	U(BD)	V(BD)	W(BD)
M	7	4	1
N	23	23	23

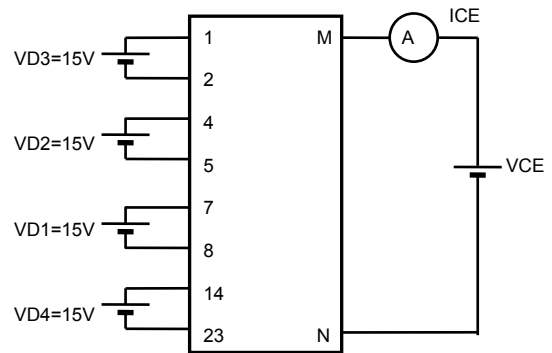

Fig.1

### ■ VCE(sat) (test by pulse)

	U+	V+	W+	U-	V-	W-
M	10	10	10	8	5	2
N	8	5	2	12	12	12
m	15	16	17	18	19	20

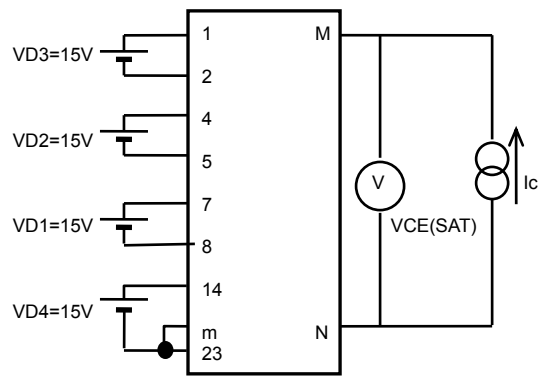

Fig.2

### ■ VF (test by pulse)

	U+	V+	W+	U-	V-	W-
M	10	10	10	8	5	2
N	8	5	2	12	12	12

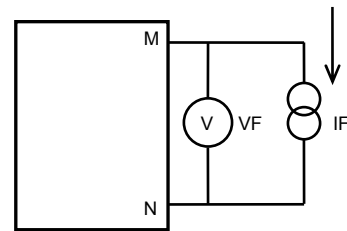

Fig.3

### ■ ID

	VD1	VD2	VD3	VD4
M	7	4	1	14
N	8	5	2	23

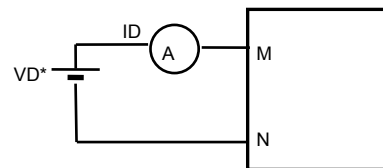

Fig.4

# STK541UC62K-E

## ■ ISD

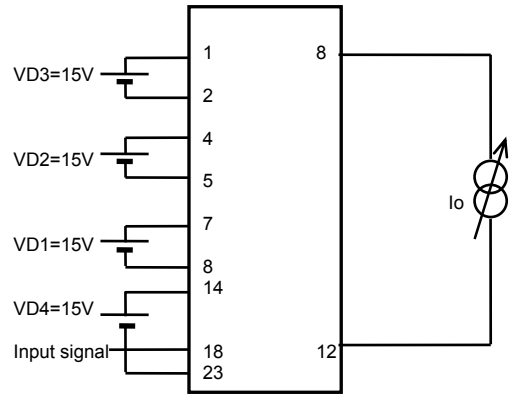
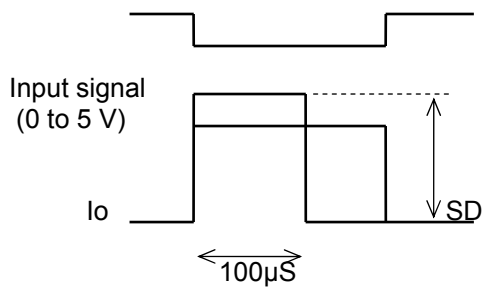

Fig.5

## ■ Switching time (The circuit is a representative example of the lower side U phase.)

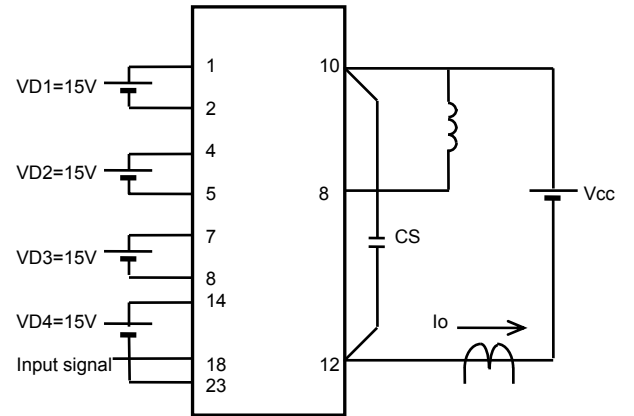
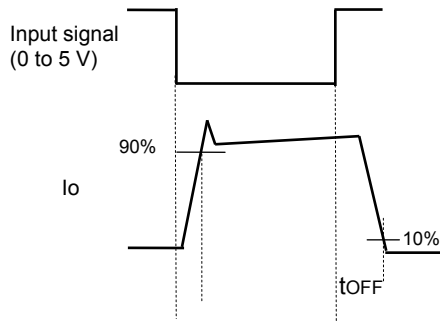

Fig.6

Input / Output Timing Diagram

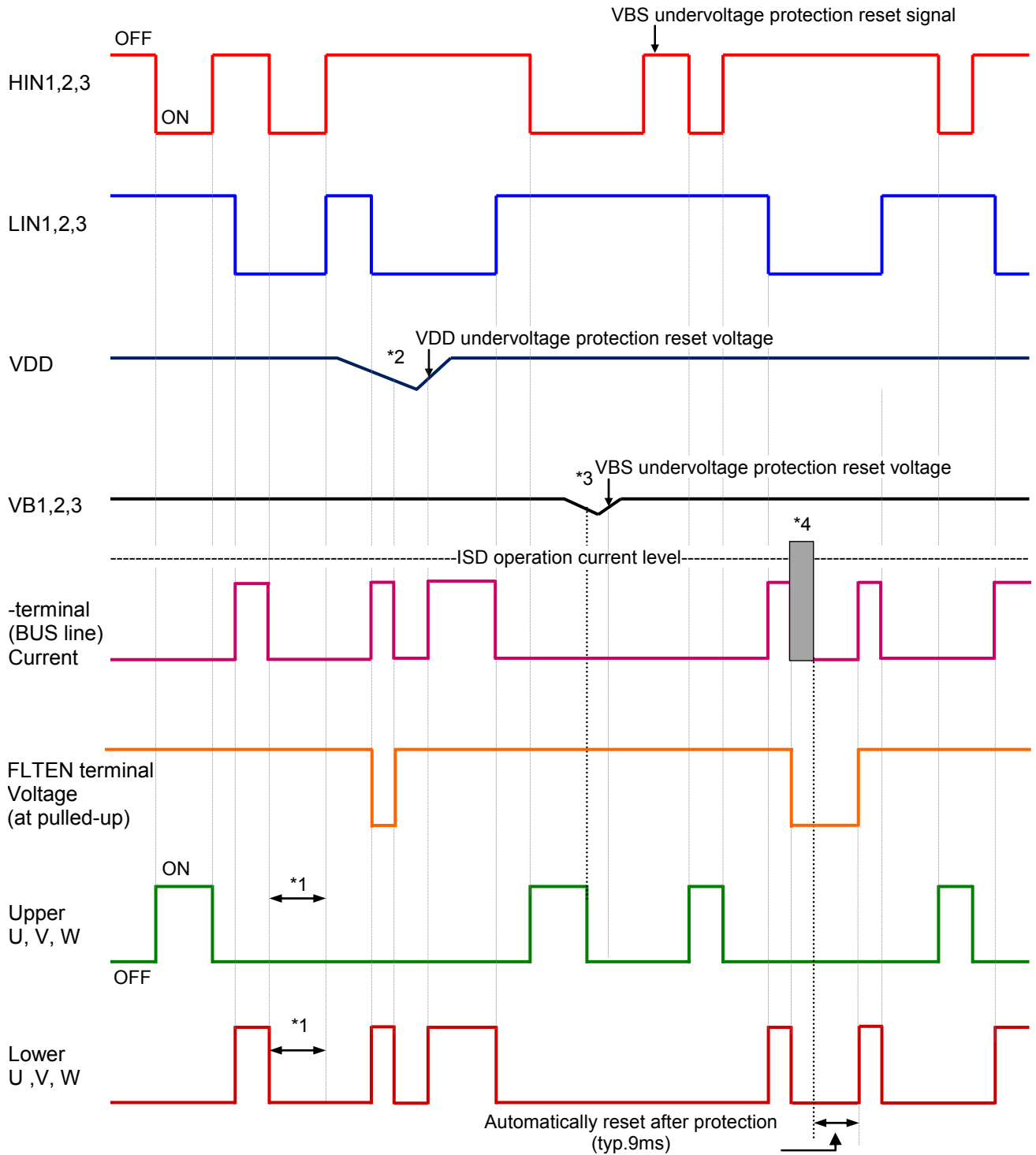
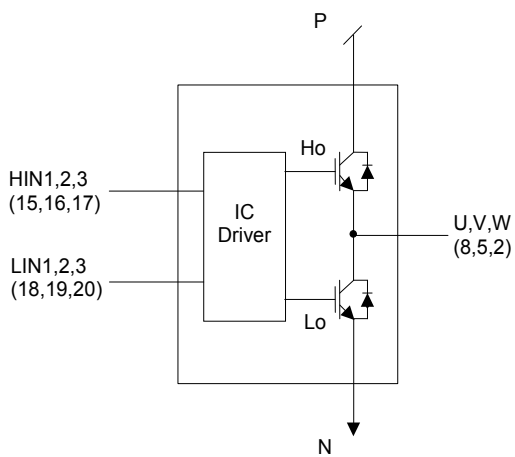

Fig.7

Notes

- \*1 : Diagram shows the prevention of shoot-through via control logic. More dead time to account for switching delay needs to be added externally.
- \*2 : When  $V_{DD}$  decreases all gate output signals will go low and cut off all of 6 IGBT outputs. When  $V_{DD}$  rises the operation will resume immediately.
- \*3 : When the upper side gate voltage at VB1, VB2 and VB3 drops only, the corresponding upper side output is turned off. The outputs return to normal operation immediately after the upper side gate voltage rises.
- \*4 : In case of over current detection, all IGBT's are turned off and the FAULT output is asserted. Normal operation resumes in 6 to 12ms after the over current condition is removed.

Logic level table



INPUT				OUTPUT			
HIN	LIN	OCP	FAULTEN	Upper IGBT	Lower IGBT	U,V,W	FAULTEN
H	L	OFF	Pulled-UP	OFF	ON	N	OFF
L	H	OFF	Pulled-UP	ON	OFF	P	OFF
L	L	OFF	Pulled-UP	OFF	OFF	High Impedance	OFF
H	H	OFF	Pulled-UP	OFF	OFF	High Impedance	OFF
X	X	ON	Pulled-UP	OFF	OFF	High Impedance	ON
X	X	OFF	L	OFF	OFF	High Impedance	ON

Fig. 8

# STK541UC62K-E

## Sample Application Circuit

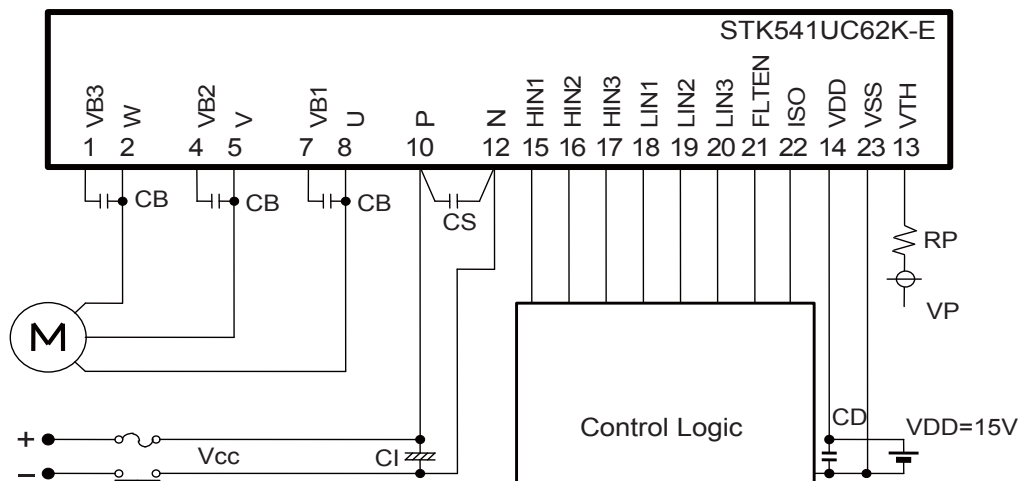

Fig. 9

## Recommended Operating Conditions

Item	Symbol	Conditions	min	typ	max	Unit
Supply voltage	V <sub>CC</sub>	P to N	0	280	450	V
Pre-driver supply voltage	VD1, 2, 3	VB1 to U, VB2 to V, VB3 to W	12.5	15	17.5	V
	VD4	V <sub>DD</sub> to V <sub>SS</sub> *1	13.5	15	16.5	
ON-state input voltage	V <sub>IN(ON)</sub>	HIN1, HIN2, HIN3, LIN1, LIN2, LIN3	0	-	0.3	V
OFF-state input voltage	V <sub>IN(OFF)</sub>		3.0	-	5.0	
PWM frequency	f <sub>PWM</sub>	-	1	-	20	kHz
Dead time	DT	Turn-off to turn-on	2	-	-	μs
Allowable input pulse width	P <sub>WIN</sub>	ON and OFF	1	-	-	μs
Tightening torque	-	'M3' type screw	0.6	-	0.9	Nm

\*1 Pre-drive power supply (VD4 = 15 ±1.5 V) must have the capacity of I<sub>o</sub> = 20 mA (DC), 0.5 A (Peak).

Functional operation above the stresses listed in the Recommended Operating Ranges is not implied. Extended exposure to stresses beyond the Recommended Operating Ranges limits may affect device reliability.

## Usage Precaution

- This IPM includes bootstrap diode and resistors. Therefore, by adding a capacitor "CB", a high side drive voltage is generated; each phase requires an individual bootstrap capacitor. The recommended value of CB is in the range of 1 to 47 μF, however this value needs to be verified prior to production. If selecting the capacitance more than 47 μF (±20%), connect a resistor (about 20 Ω) in series between each 3-phase upper side power supply terminals (VB1,2,3) and each bootstrap capacitor. When not using the bootstrap circuit, each upper side pre-drive power supply requires an external independent power supply.
- It is essential that wiring length between terminals in the snubber circuit be kept as short as possible to reduce the effect of surge voltages. Recommended value of "CS" is in the range of 0.1 to 10 μF.
- "ISO" (pin22) is terminal for current monitor. When the pull-down resistor is used, please select it more than 5.6 kΩ
- "FLTEN" (pin21) is open DRAIN output terminal (Active Low). Pull up resistor is recommended more than 5.6 kΩ.
- Inside the IPM, a thermistor used as the temperature monitor for internal substrate is connected between V<sub>SS</sub> terminal and V<sub>TH</sub> terminal, therefore, an external pull up resistor connected between the TH terminal and an external power supply should be used. The temperature monitor example application is as follows, please refer the Fig.10 and below.
- The over-current protection feature is not intended to protect in exceptional fault condition. An external fuse is recommended for safety.
- When "N" and "V<sub>SS</sub>" terminal are short-circuited on the outside, level that over-current protection (ISD) might be changed from designed value as IPM. Please check it in your set ("N" terminal and "V<sub>SS</sub>" terminal are connected in IPM).
- When input pulse width is less than 1.0 μs, an output may not react to the pulse. (Both ON signal and OFF signal)

This data shows the example of the application circuit, does not guarantee a design as the mass production set.

The characteristic of thermistor

Parameter	Symbol	Condition	Min	Typ.	Max	Unit
Resistance	$R_{25}$	$T_c = 25^\circ\text{C}$	99	100	101	k $\Omega$
Resistance	$R_{100}$	$T_c = 100^\circ\text{C}$	5.12	5.38	5.66	k $\Omega$
B-Constant (25 to 50 °C)	B		4165	4250	4335	K
Temperature Range			-40	-	+125	$^\circ\text{C}$

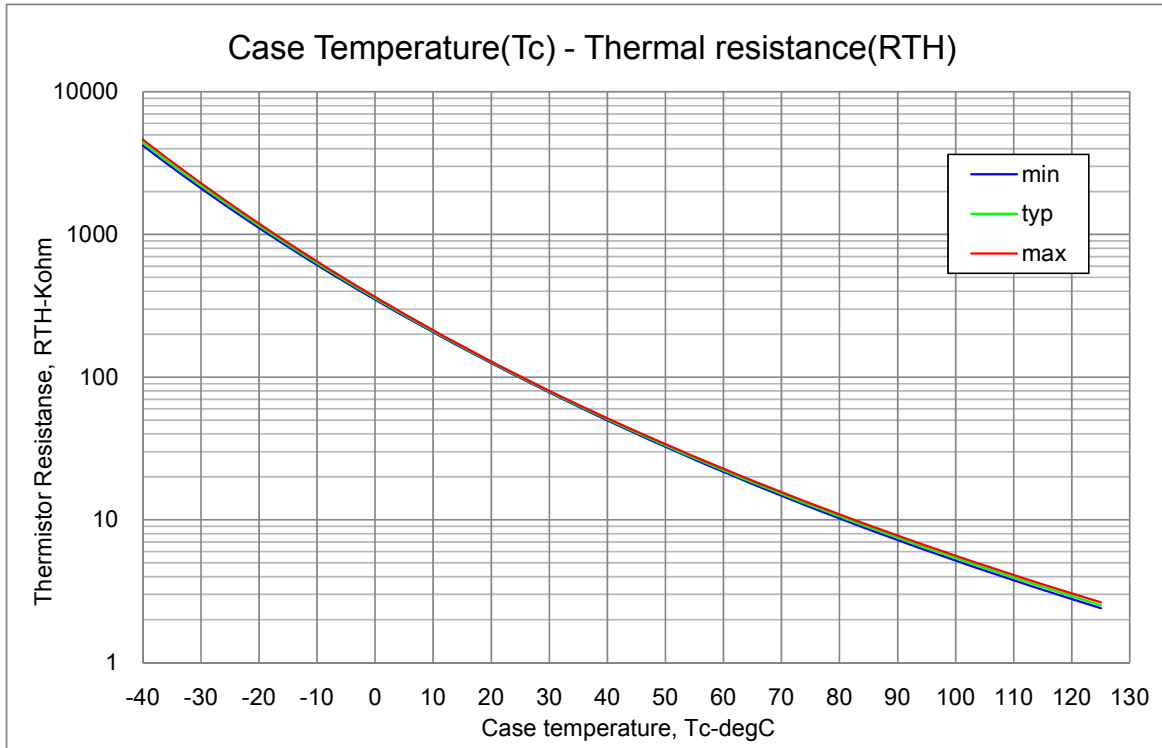

Fig.10 Variation of thermistor resistance with temperature

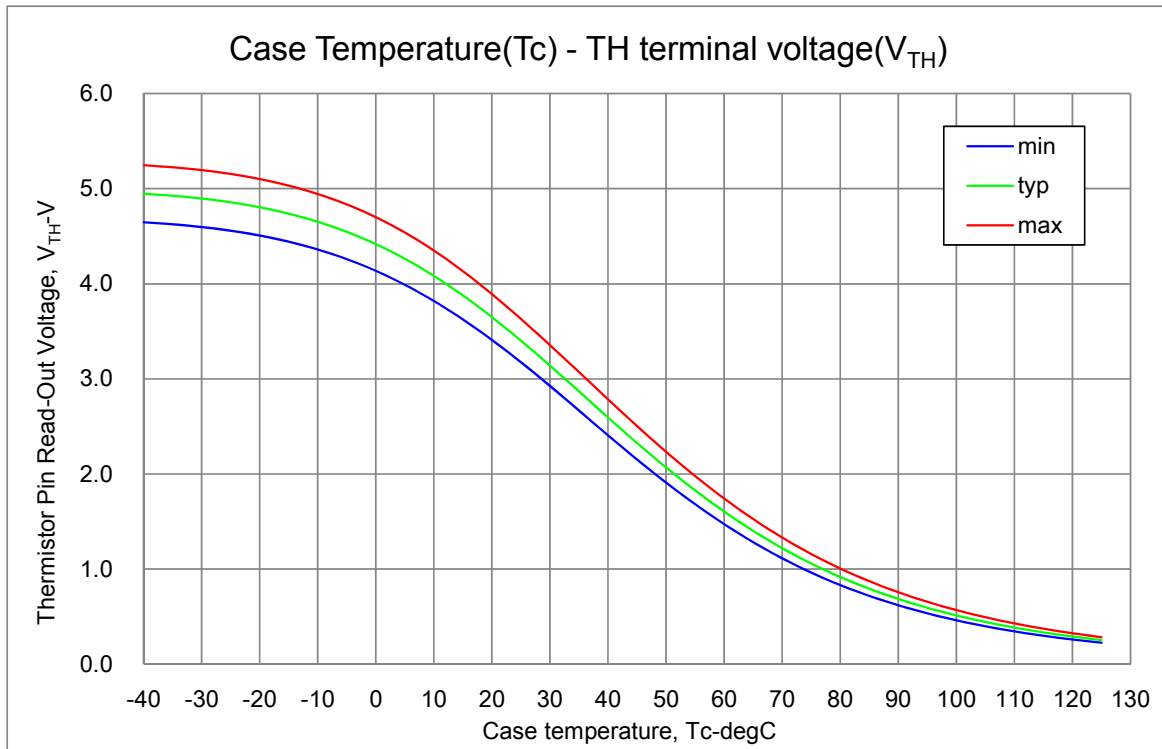

Fig.11 Variation of thermistor terminal voltage with temperature (47 k $\Omega$  pull-up resistor, 5 V)

# STK541UC62K-E

## The characteristic of PWM switching frequency

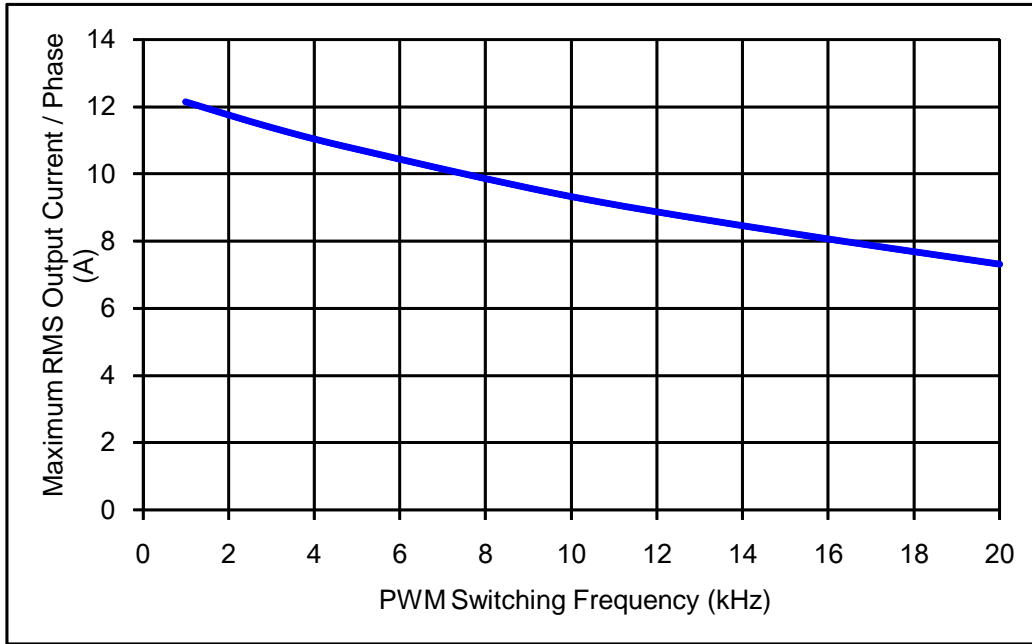

Fig. 12 Maximum sinusoidal phase current as function of switching frequency  
at  $T_c = 100^\circ\text{C}$ ,  $V_{CC} = 400\text{ V}$

# STK541UC62K-E

## CB capacitor value calculation for bootstrap circuit

### Calculate conditions

Parameter	Symbol	Value	Unit
Upper side power supply	VBS	15	V
Total gate charge of output power IGBT at 15 V	QG	89	nC
Upper limit power supply low voltage protection	UVLO	12	V
Upper side power dissipation	IDMAX	400	μA
ON time required for CB voltage to fall from 15 V to UVLO	TONMAX	–	s

### Capacitance calculation formula

Thus, the following formula are true  
 $VBS \times CB - QG - IDMAX \times TONMAX = UVLO \times CB$   
therefore,  
 $CB = (QG + IDMAX \times TONMAX) / (VBS - UVLO)$

The relationship between TONMAX and CB becomes as follows. CB is recommended to be approximately 3 times the value calculated above. The recommended value of CB is in the range of 1 to 47 μF, however, this value needs to be verified prior to production.

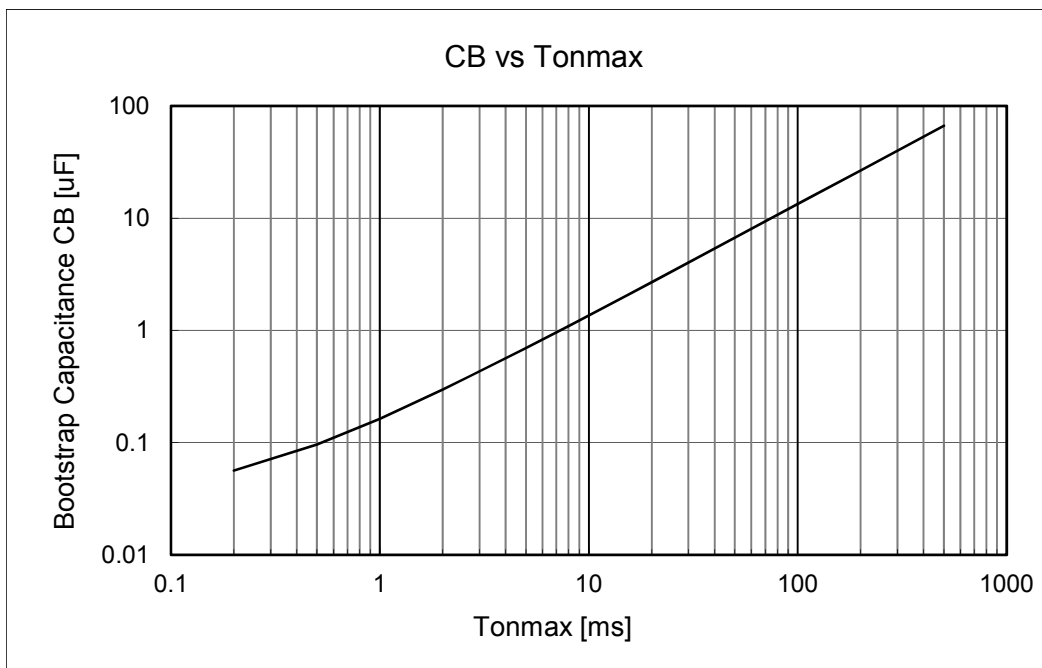

Fig. 15 Tonmax - CB characteristic

# STK541UC62K-E

## PACKAGE DIMENSIONS

unit : mm

The tolerances of length are +/- 0.5 mm unless otherwise specified.

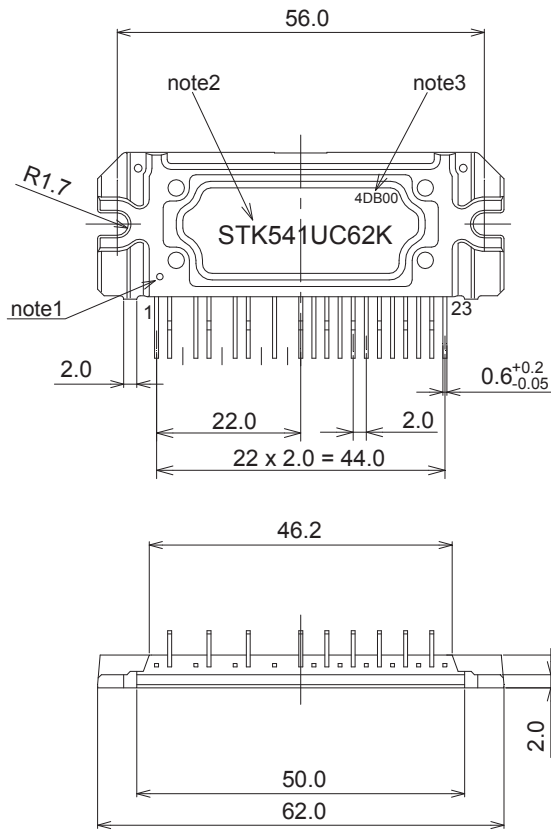

missing pin ; 3, 6, 9, 11

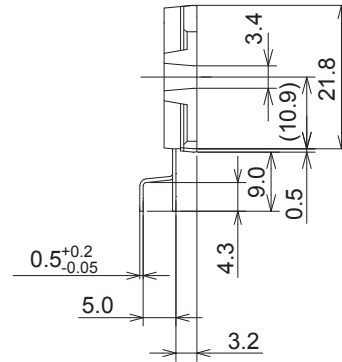

- note1 : Mark for No.1 pin identification.
- note2 : The form of a character in this drawing differs from that of IPM.
- note3 : This indicates the date code.  
The form of a character in this drawing differs from that of IPM.

# STK541UC62K-E

## ORDERING INFORMATION

Device	Package	Shipping (Qty / Packing)
STK541UC62K-E	SIP23 56x21.8 (Pb-Free)	8 / Tube

ON Semiconductor and the ON Semiconductor logo are trademarks of Semiconductor Components Industries, LLC dba ON Semiconductor or its subsidiaries in the United States and/or other countries. ON Semiconductor owns the rights to a number of patents, trademarks, copyrights, trade secrets, and other intellectual property. A listing of ON Semiconductor's product/patent coverage may be accessed at [www.onsemi.com/site/pdf/Patent-Marking.pdf](http://www.onsemi.com/site/pdf/Patent-Marking.pdf). ON Semiconductor reserves the right to make changes without further notice to any products herein. ON Semiconductor makes no warranty, representation or guarantee regarding the suitability of its products for any particular purpose, nor does ON Semiconductor assume any liability arising out of the application or use of any product or circuit, and specifically disclaims any and all liability, including without limitation special, consequential or incidental damages. Buyer is responsible for its products and applications using ON Semiconductor products, including compliance with all laws, regulations and safety requirements or standards, regardless of any support or applications information provided by ON Semiconductor. "Typical" parameters which may be provided in ON Semiconductor data sheets and/or specifications can and do vary in different applications and actual performance may vary over time. All operating parameters, including "Typicals" must be validated for each customer application by customer's technical experts. ON Semiconductor does not convey any license under its patent rights nor the rights of others. ON Semiconductor products are not designed, intended, or authorized for use as a critical component in life support systems or any FDA Class 3 medical devices or medical devices with a same or similar classification in a foreign jurisdiction or any devices intended for implantation in the human body. Should Buyer purchase or use ON Semiconductor products for any such unintended or unauthorized application, Buyer shall indemnify and hold ON Semiconductor and its officers, employees, subsidiaries, affiliates, and distributors harmless against all claims, costs, damages, and expenses, and reasonable attorney fees arising out of, directly or indirectly, any claim of personal injury or death associated with such unintended or unauthorized use, even if such claim alleges that ON Semiconductor was negligent regarding the design or manufacture of the part. ON Semiconductor is an Equal Opportunity/Affirmative Action Employer. This literature is subject to all applicable copyright laws and is not for resale in any manner.