

Product Specification

100m Dual-rate Parallel MMF 100G CFP4 Optical Transceiver FTLC9141SENM

PRODUCT FEATURES

- Hot-pluggable CFP4 form factor
- Supports 103.1Gb/s and 111.8Gb/s aggregate bit rates
- Power dissipation < 4W
- RoHS compliant
- Commercial case temperature range of 0 °C to 70 °C
- Single 3.3V power supply
- Maximum link length of 100m on OM4 Multimode Fiber (MMF)
- 4x28Gb/s 850nm VCSEL-based transmitter
- 4x28G electrical interface
- Single MPO12 receptacle
- MDIO management interface



APPLICATIONS

- 100GBASE-SR4 100G Ethernet
- 4x28Gb/s Multimode OTN

Finisar's FTLC9141SENM 100G CFP4 transceiver modules are designed for use in 100 Gigabit Ethernet links and 4x28G OTN client interfaces over multimode fiber. They are compliant with the CFP4 MSA¹, IEEE 802.3ba 100GBASE-SR4 and CAUI-4², and OIF CEI-28G-VSR⁵. Digital diagnostics functions are available via the MDIO interface, as specified by the CFP MSA and Finisar Application Note AN-20xx⁴. The transceiver is RoHS compliant per Directive 2011/65/EU³.

PRODUCT SELECTION

FTLC9141SENM

- S: OTU4 maximum bit rate (111.8 Gb/s)
- E: 4x25G/28G parallel optics
- N: Bail type release
- M: MPO receptacle

I. Pin Descriptions

Per CFP MSA¹.

Pins views from the top.

| | Top Row | | Bottom Row |
|----|------------------|----|----------------|
| 56 | GND | 1 | 3.3V_GND |
| 55 | TX3n | 2 | 3.3V_GND |
| 54 | TX3p | 3 | 3.3V |
| 53 | GND | 4 | 3.3V |
| 52 | TX2n | 5 | 3.3V |
| 51 | TX2p | 6 | 3.3V |
| 50 | GND | 7 | 3.3V_GND |
| 49 | TX1n | 8 | 3.3V_GND |
| 48 | TX1p | 9 | VND_IO_A |
| 47 | GND | 10 | VND_IO_B |
| 46 | TX0n | 11 | TX_DIS |
| 45 | TX0p | 12 | RX_LOS |
| 44 | GND | 13 | GLB_ALRMn |
| 43 | <i>{REFCLKn}</i> | 14 | MOD_LOPWR |
| 42 | <i>{REFCLKp}</i> | 15 | MOD_ABS |
| 41 | GND | 16 | MOD_RSTn |
| 40 | RX3n | 17 | MDC |
| 39 | RX3p | 18 | MDIO |
| 38 | GND | 19 | PRTADR0 |
| 37 | RX2n | 20 | PRTADR1 |
| 36 | RX2p | 21 | PRTADR2 |
| 35 | GND | 22 | VND_IO_C |
| 34 | RX1n | 23 | VND_IO_D |
| 33 | RX1p | 24 | VND_IO_E |
| 32 | GND | 25 | GND |
| 31 | RX0n | 26 | <i>{MCLKn}</i> |
| 30 | RX0p | 27 | <i>{MCLKp}</i> |
| 29 | GND | 28 | GND |

Bottom Row Pin Descriptions

| PIN # | Name | I/O | Logic | Description |
|-------|-----------|-----|----------------|--|
| 1 | 3.3V_GND | | | 3.3V Module Supply Voltage Return Ground, internally connected to Signal Ground |
| 2 | 3.3V_GND | | | 3.3V Module Supply Voltage Return Ground, internally connected to Signal Ground |
| 3 | 3.3V | | | 3.3V Module Supply Voltage |
| 4 | 3.3V | | | 3.3V Module Supply Voltage |
| 5 | 3.3V | | | 3.3V Module Supply Voltage |
| 6 | 3.3V | | | 3.3V Module Supply Voltage |
| 7 | 3.3V_GND | | | 3.3V Module Supply Voltage Return Ground, internally connected to Signal Ground |
| 8 | 3.3V_GND | | | 3.3V Module Supply Voltage Return Ground, internally connected to Signal Ground |
| 9 | VND_IO_A | I/O | | Module Vendor I/O A. Do Not Connect! |
| 10 | VND_IO_B | I/O | | Module Vendor I/O B. Do Not Connect! |
| 11 | TX_DIS | I | LVC MOS w/ PUR | Transmitter Disable for all lanes, "1" or NC = transmitter disabled, "0" = transmitter enabled |
| 12 | RX_LOS | O | LVC MOS | Receiver Loss of Optical Signal, "1": low optical signal, "0": normal condition |
| 13 | GLB_ALRMn | O | LVC MOS | Global Alarm. "0": alarm condition in any MDIO Alarm register, "1": no alarm condition, Open Drain, Pull Up Resistor on Host |
| 14 | MOD_LOPWR | I | LVC MOS w/ PUR | Module Low Power Mode. "1" or NC: module in low power (safe) mode, "0": power-on enabled |
| 15 | MOD_ABS | O | GND | Module Absent. "1" or NC: module absent, "0": module present, Pull Up Resistor on Host |
| 16 | MOD_RSTn | I | LVC MOS w/ PDR | Module Reset. "0" resets the module, "1" or NC = module enabled, Pull Down Resistor in Module |
| 17 | MDC | I/O | 1.2V CMOS | Management Data I/O bi-directional data (electrical specs as per 802.3ae and ba) |
| 18 | MDIO | I | 1.2V CMOS | Management Data Clock (electrical specs as per 802.3ae and ba) |
| 19 | PRTADR0 | I | 1.2V CMOS | MDIO Physical Port address bit 0 |
| 20 | PRTADR1 | I | 1.2V CMOS | MDIO Physical Port address bit 1 |
| 21 | PRTADR2 | I | 1.2V CMOS | MDIO Physical Port address bit 2 |
| 22 | VND_IO_C | I/O | | Module Vendor I/O C. Do Not Connect! |
| 23 | VND_IO_D | I/O | | Module Vendor I/O D. Do Not Connect! |
| 24 | VND_IO_E | I/O | | Module Vendor I/O E. Do Not Connect! |
| 25 | GND | | | |
| 26 | MCLKn | | | Monitor Clock |
| 27 | MCLKp | | | Monitor Clock |
| 28 | GND | | | |

II. Absolute Maximum Ratings

Module performance is not guaranteed beyond the operating range (see Section VI). Exceeding the limits below may damage the transceiver module permanently.

| Parameter | Symbol | Min | Typ | Max | Unit | Ref. |
|-------------------------------------|-------------------|------|-----|-----|------|------|
| Maximum Supply Voltage | V _{CC} | -0.5 | | 4.0 | V | |
| Storage Temperature | T _S | -40 | | 85 | °C | |
| Case Operating Temperature | T _{OP} | 0 | | 70 | °C | 1 |
| Relative Humidity | RH | 15 | | 85 | % | 2 |
| Receiver Damage Threshold, per Lane | P _{Rdmg} | 5.5 | | | dBm | |

Notes:

- 48-hour excursions, maximum
- Non-condensing.

III. Electrical Characteristics (EOL, T_{OP} = 0 to 70°C, V_{CC} = 3.2 to 3.4 Volts)

| Parameter | Symbol | Min | Typ | Max | Unit | Ref. |
|--|---------------------------------|--|-----|-------|------|------|
| Supply Voltage | V _{CC} | 3.2 | | 3.4 | V | |
| Supply Current | I _{CC} | | | TBD | A | |
| Module total power | P | | | 4 | W | 1 |
| Transmitter | | | | | | |
| Signaling rate per lane | | 25.78 | | 27.95 | Gb/s | 2 |
| Differential pk-pk input voltage tolerance | V _{in,pp,diff} | | | 900 | mV | |
| Single-ended voltage tolerance | V _{in,pp} | -0.35 | | +3.30 | V | |
| Module stress input test | | Per Section 13.3.11.2.1, OIF CEI-28G-VSR | | | | |
| Receiver | | | | | | |
| Signaling rate per lane | | 25.78 | | 27.95 | Gb/s | 2 |
| Differential output voltage | V _{out,pp} | | | 900 | mV | |
| Eye width | | 0.57 | | | UI | |
| Eye height, differential | | 228 | | | mV | |
| Vertical eye closure | VEC | 5.5 | | | dB | |
| Transition time (20% to 80%) | t _r , t _f | 9.5 | | | ps | |

Notes:

- Maximum total power value is specified across the full temperature and voltage range.
- +/- 100ppm

FTLC9141SENM Clocking Signals

| Clock Name | Status | I/O | Value |
|------------|--------------|-----|----------|
| REFCLK | Not Required | I | Optional |
| MCLK | Supported | O | N/A |

IV. Optical Characteristics (EOL, T_{OP} = 0 to 70°C, V_{CC} = 3.2 to 3.4 Volts)

OTU4 Operation

| Parameter | Symbol | Min | Typ | Max | Unit | Ref. |
|--|------------------|----------------------------------|-----|-------|------|------|
| Transmitter | | | | | | |
| Signaling Speed per Lane | | 27.95 | | 27.95 | Gb/s | 1 |
| Center wavelength | | 840 | 850 | 860 | nm | |
| RMS Spectral Width | SW | | | 0.6 | nm | |
| Average Launch Power per Lane | TXP _x | -9 | | 2.4 | dBm | |
| Transmit OMA per Lane | TxOMA | -7.1 | | 3.0 | dBm | |
| Launch Power [OMA] minus TDEC per Lane | P-TDEC | -8.0 | | | dBm | |
| TDEC per Lane | TDEC | | | 5.0 | dB | |
| Optical Extinction Ratio | ER | 3 | | | dB | |
| Encircled Flux | FLX | >86% at 19um, <30% at 4.5um | | | dBm | |
| Average launch power of OFF transmitter, per lane | | | | -30 | dBm | |
| Transmitter eye mask definition {X1, X2, X3, Y1, Y2, Y3} | | {0.31,0.41,0.46, 0.35,0.38,0.50} | | | | 2 |
| Optical Return Loss Tolerance | ORL | | | 12 | dB | |
| Receiver | | | | | | |
| Signaling Speed per Lane | | 27.95 | | 27.95 | Gb/s | 3 |
| Center wavelength | | | 850 | | nm | |
| Damage Threshold | DT | 3.4 | | | dBm | |
| Average Receive Power per Lane | RXP _x | -10.9 | | 2.4 | dBm | 4 |
| Receive Power (OMA) per Lane | RxOMA | | | 3.0 | dBm | |
| Stressed Receiver Sensitivity (OMA) per Lane | SRS | | | -4.7 | dBm | 5 |
| Receiver Reflectance | Rfl | | | -12 | dB | |
| Stressed receiver eye mask definition {X1, X2, X3, Y1, Y2, Y3} | | {0.29,0.50,0.50, 0.35,0.35,0.40} | | | | 6 |
| LOS De-Assert | LOS _D | | | -13 | dBm | |
| LOS Assert | LOS _A | -30 | -17 | | dBm | |
| LOS Hysteresis | | 0.5 | 2 | | dB | |

Notes:

1. Transmitter consists of 4 lasers operating at a maximum speed of 27.95Gb/s each.
2. Hit ratio = 1.5×10^{-3} hits/sample.
3. Receiver consists of 4 photodetectors operating at a maximum speed of 27.95Gb/s each.
4. Minimum value is informative only and not the principal indicator of signal strength.
5. Test conditions for measuring SRS defined as follows:

| | | | | | | |
|---|--|------|---|------|-----|--|
| Stressed eye closure, lane under test | | | | 5.0 | dB | |
| Stressed eye J2 jitter, lane under test | | 0.38 | | | UI | |
| Stressed eye J4 jitter, lane under test | | | | 0.51 | UI | |
| OMA of each aggressor lane | | | 3 | | dBm | |

Stressed Eye Closure (SEC) is measured per IEEE 802.3 95.8.8 (reference [22]), but adjusted to 1×10^{-6} instead of 1×10^{-5} bit error ratio. Thus SEC is given by $SEC = 10 \log_{10} [OMA / (2 * 4.2649 * R)]$ with R as defined by equation (95-3) in 95.8.5. The values of M1 and M2 in equation (95-3) are set to zero. The combination of the O/E and the oscilloscope used to measure the waveform has a fourth-order Bessel-Thomson filter response with a bandwidth of 19.34 GHz.

6. Hit ratio = 1×10^{-5} hits/sample.

100GBASE-SR4 Operation

| Parameter | Symbol | Min | Typ | Max | Unit | Ref. |
|--|------------------|--------------------------------------|-----|-------|------|------|
| Transmitter | | | | | | |
| Signaling Speed per Lane | | 25.78 | | 25.78 | Gb/s | 1 |
| Center wavelength | | 840 | 850 | 860 | nm | |
| RMS Spectral Width | SW | | | 0.6 | nm | |
| Average Launch Power per Lane | TXP _x | -8.4 | | 2.4 | dBm | |
| Transmit OMA per Lane | TxOMA | -6.4 | | 3.0 | dBm | |
| Launch Power [OMA] minus TDEC per Lane | P-TDEC | -7.3 | | | dBm | |
| TDEC per Lane | TDEC | | | 4.3 | dB | |
| Optical Extinction Ratio | ER | 2 | | | dB | |
| Encircled Flux | FLX | >86% at 19um, <30% at 4.5um | | | dBm | |
| Average launch power of OFF transmitter, per lane | | | | -30 | dBm | |
| Transmitter eye mask definition {X1, X2, X3, Y1, Y2, Y3} | | {0.30, 0.38, 0.45, 0.35, 0.41, 0.50} | | | | 2 |
| Optical Return Loss Tolerance | ORL | | | 12 | dB | |
| Receiver | | | | | | |
| Signaling Speed per Lane | | 25.78 | | 25.78 | Gb/s | 3 |
| Center wavelength | | | 850 | | nm | |
| Damage Threshold | DT | 3.4 | | | dBm | |
| Average Receive Power per Lane | RXP _x | -10.3 | | 2.4 | dBm | 4 |
| Receive Power (OMA) per Lane | RxOMA | | | 3.0 | dBm | |
| Stressed Receiver Sensitivity (OMA) per Lane | SRS | | | -5.2 | dBm | 5 |
| Receiver Reflectance | Rfl | | | -12 | dB | |
| Stressed receiver eye mask definition {X1, X2, X3, Y1, Y2, Y3} | | {0.28, 0.50, 0.50, 0.33, 0.33, 0.40} | | | | 5, 6 |
| LOS De-Assert | LOS _D | | | -13 | dBm | |
| LOS Assert | LOS _A | | -15 | | dBm | |
| LOS Hysteresis | | 2 | | | dB | |

Notes:

1. Transmitter consists of 4 lasers operating at a maximum speed of 25.78Gb/s each.
2. Hit ratio = 1.5×10^{-3} hits/sample.
3. Receiver consists of 4 photodetectors operating at a maximum speed of 25.78Gb/s each.
4. Minimum value is informative only and not the principal indicator of signal strength.
5. Test conditions for measuring SRS as defined in 100GBASE-SR4.
6. Hit ratio = 5×10^{-5} hits/sample.

V. General Specifications

| Parameter | Symbol | Min | Typ | Max | Units | Ref. |
|-------------------------------------|--------|-------|-----|--------------------|-------|------|
| Bit Rate (all wavelengths combined) | BR | 103.1 | | 111.8 | Gb/s | 1 |
| Bit Error Ratio @25.78Gb/s | BER1 | | | 5×10^{-5} | | 2 |
| Bit Error Ratio @27.95Gb/s | BER2 | | | 10^{-6} | | 3 |
| Maximum Supported Distances | | | | | | |
| Fiber Type | | | | | | |
| OM3 MMF | Lmax1 | | | 70 | m | 4 |
| OM4 MMF | Lmax2 | | | 100 | m | 4 |

Notes:

- Supports 100GBASE-SR4 per IEEE 802.3bm and multimode 4x28G OTN.
- Tested with a $2^{31} - 1$ PRBS.
- Tested with a $2^{31} - 1$ PRBS. The BER of 10^{-12} for the OTU4 (111.8 Gb/s) application code is required to be met only after forward error correction has been applied. ITU-T G.sup39 defines the pre-FEC BER to be met as 10^{-6} . The values for receiver sensitivity and optical path penalty measured at the receiver output at a BER of 10^{-6} will normally be conservative estimates of the values for receiver sensitivity and path penalty at the BER of 10^{-12} after the FEC decoder.
- Requires FEC on the host to support maximum link distance. Connector loss accounts for 1 dB loss.

VI. Environmental Specifications

Finisar FTLC9141 CFP4 transceivers have a commercial operating case temperature range of 0 °C to +70 °C. They can support temporary excursions to case temperatures of -5 °C and +75 °C without permanent damage (see Section II).

| Parameter | Symbol | Min | Typ | Max | Units | Ref. |
|----------------------------|------------------|-----|-----|-----|-------|------|
| Case Operating Temperature | T _{op} | 0 | | 70 | °C | |
| Storage Temperature | T _{sto} | -40 | | 85 | °C | |

VII. Regulatory Compliance

Finisar FTLC9141 CFP4 transceivers are Class 1 Laser Products. They are certified per the following standards:

| Feature | Agency | Standard | Certificate Number |
|-------------------|----------|---|--------------------|
| Laser Eye Safety | FDA/CDRH | CDRH 21 CFR 1040 and Laser Notice 50 | 9210176 |
| Laser Eye Safety | TÜV | EN 60825-1: 2007 IEC 60825-2: 2004+A1+A2 | R 72130387 |
| Electrical Safety | TÜV | EN 60950 | R 72130387 |
| Electrical Safety | UL/CSA | CLASS 3862.07 CLASS 3862.87 | 190993- 2375840 |

Copies of the referenced certificates will be available at Finisar upon request.

Complies with FDA performance standards for laser products except for deviations pursuant to Laser Notice No. 50, dated June 24, 2007.

VIII. Digital Diagnostics Functions

FTLC9141 CFP4 transceivers support the MDIO-based diagnostics interface specified by the CFP MSA¹. See Finisar Application Note AN-20xx (TBD).

IX. Memory Contents

Per the CFP MSA¹. See Finisar Application Note AN-20xx (TBD).

X. Host PCB Layout and Bezel Recommendations

Per CFP MSA Hardware Specification for CFP4¹.

XI. Mechanical Specifications

Finisar FTLC9141 CFP4 transceivers are compatible with the CFP MSA specification for CFP4 pluggable form factor modules.

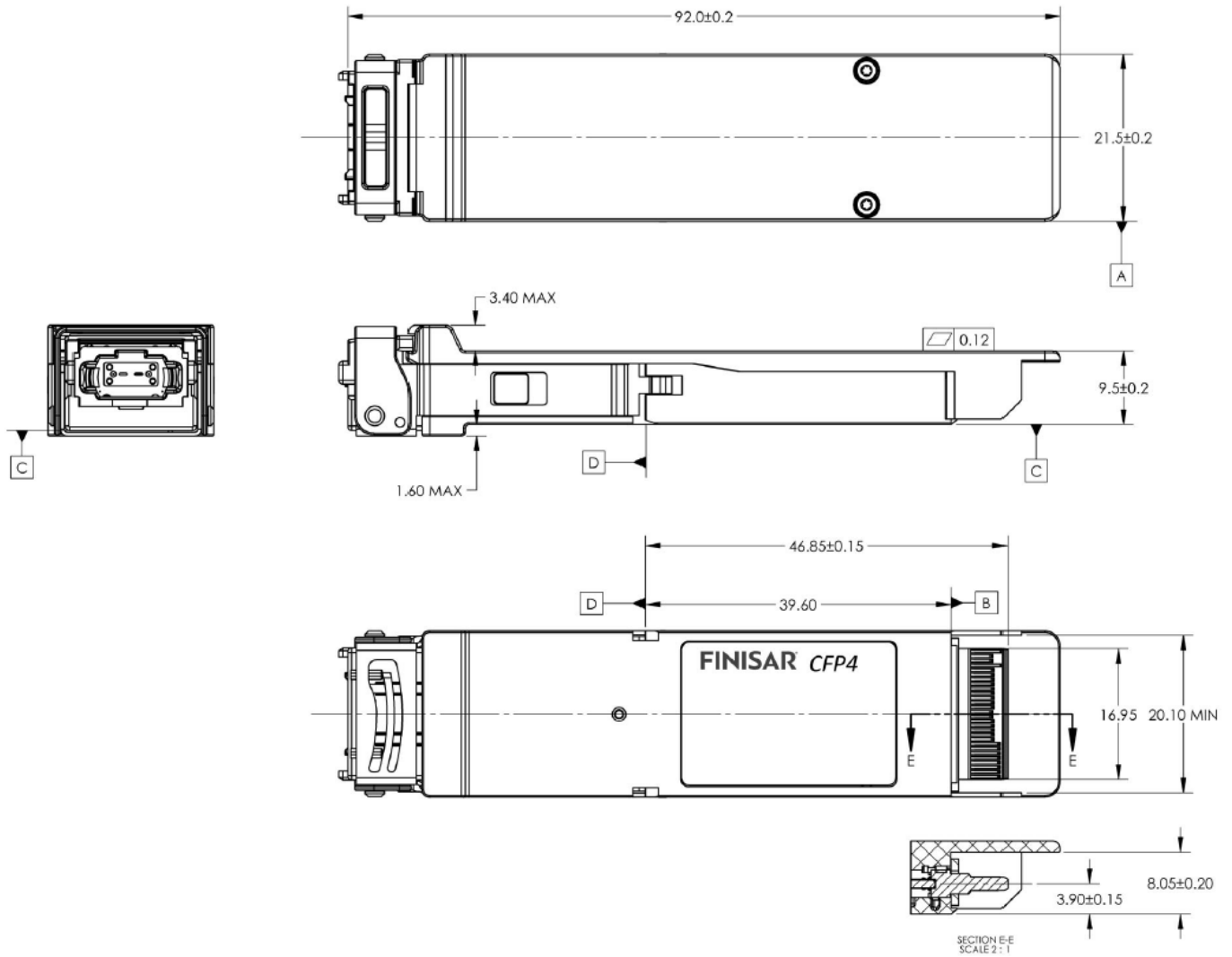

Figure 1. FTLC9141SENM Mechanical Dimensions.

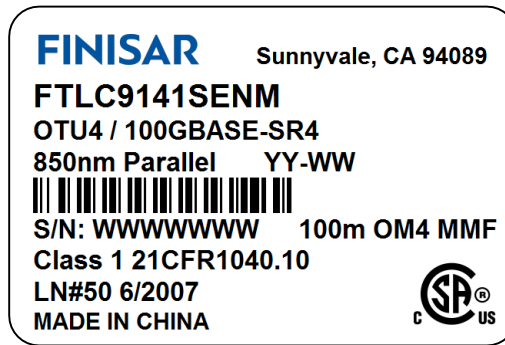

Figure 2. Standard Product Label

XII. References

1. CFP4 Hardware Specification and CFP MSA Management Interface Specifications (MIS), Rev 2.4.; CFP MSA, www.cfp-msa.org
2. IEEE 802.3bm, PMD Type 100GBASE-SR4 and Annex 83E, CAUI-4 Interface.
3. Directive 2011/65/EU of the European Parliament and of the Council, “on the restriction of the use of certain hazardous substances in electrical and electronic equipment.” Certain products may use one or more exemption as allowed by the directive.
4. Application Note AN-20xx (TBD), Finisar Corporation.
5. CEI-28G-VSR electrical interface, per Implementation Agreement OIF-CEI-03.1, Section 13, February 18, 2014.

For More Information:

Finisar Corporation
1389 Moffett Park Drive
Sunnyvale, CA 94089-1133
Tel. 1-408-548-1000
Fax 1-408-541-6138
sales@finisar.com
www.finisar.com