

# Data Sheet | Item Number: 2060-1452/998-404

THR PCB terminal block; push-button; 0.75 mm<sup>2</sup>; Pin spacing 4 mm; 2-pole; Push-in CAGE CLAMP®; in tape-and-reel packaging; white

<https://www.wago.com/2060-1452/998-404>

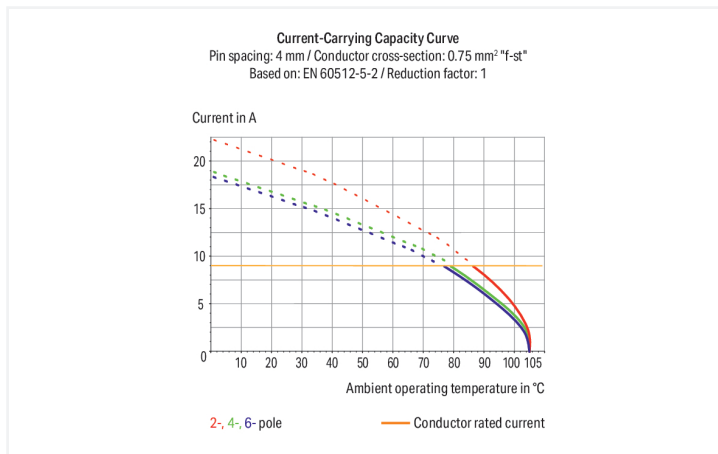

Color: ■ white

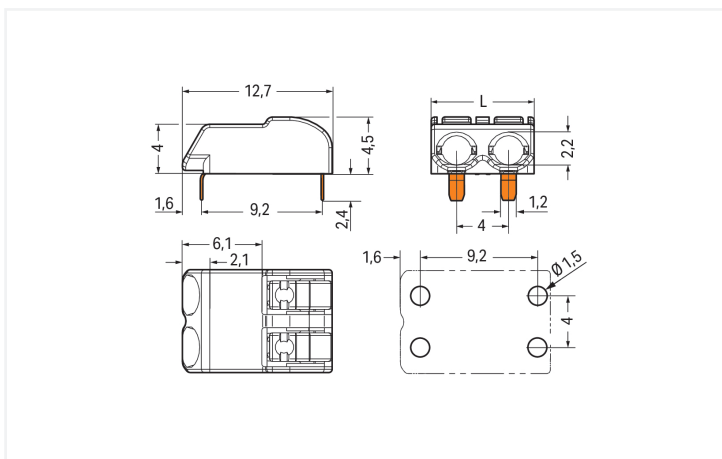

Dimensions in mm  
L = (pole no. x pin spacing) - 0.1 mm

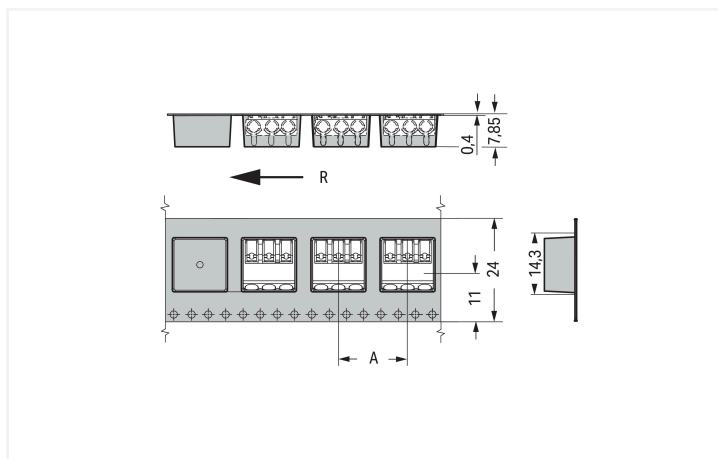

Dimensions in mm  
R = feed direction  
A = (pole no. x pin spacing) + 4 mm

## PCB terminal block, 2060 Series, Push-in CAGE CLAMP®

Easily, quickly and safely connect conductors with this PCB terminal block (item number 2060-1452/998-404). You can count on tried and tested safety with these PCB terminal blocks, perfect for a wide range of applications when designing your devices. Strip lengths must be between 6 and 7 mm when connecting conductors to this PCB terminal block. This product incorporates one conductor terminal and utilizes Push-in CAGE CLAMP®. Push-in CAGE CLAMP® connection technology is ideal for connecting all conductor types. Solid and fine-stranded conductors with ferrules can be inserted without needing to use any tools—all thanks to its pluggable design. The dimensions are (7.9 x 6.9 x 12.7) mm (width x height x depth). This PCB terminal block is suitable for conductor cross sections ranging from 0.2 mm<sup>2</sup> to 0.75 mm<sup>2</sup>.

The contact surface is coated with tin. This PCB terminal block is operated with a push-button. The PCB terminal block is designed for THR soldering. Insert the conductor into the board at a 0° angle..

## Notes

## Note

## Application notes:

Suitable for lead-free, reflow-soldering profiles per DIN EN 61760-1 and IEC 60068-2-58 up to max. 260°C peak temperature. Due to application-specific variables (component configuration and orientation, type of soldering machine, solder paste), trial runs are recommended to ensure product and process compatibility under actual manufacturing conditions.

Depending on reflow soldering temperatures and times, color deviations may occur. These deviations will have no impact on functionality.

## Recommendation

## Recommendation for stencil:

150 µm material thickness  
Stencil hole diameter identical to metal-plated PCB hole outer diameter

## Electrical data

Ratings per	IEC/EN 60664-1		
Overvoltage category	III	III	II
Pollution degree	3	2	2
Nominal voltage	63 V	160 V	320 V
Rated impulse withstand voltage	2.5 kV	2.5 kV	2.5 kV
Rated current	9 A	9 A	9 A

## Ratings

Approvals per	UL 1977
Rated voltage	600 V
Rated current	9 A

## Connection Data

Clamping units	2
Total number of potentials	2
Number of connection types	1
Number of levels	1

## Connection 1

Connection technology	Push-in CAGE CLAMP®
Actuation type	Push-button
Solid conductor	0.2 ... 0.75 mm <sup>2</sup> / 24 ... 18 AWG
Fine-stranded conductor	0.2 ... 0.75 mm <sup>2</sup> / 24 ... 18 AWG
Fine-stranded conductor; with insulated ferrule	0.25 ... 0.34 mm <sup>2</sup>
Fine-stranded conductor; with uninsulated ferrule	0.25 ... 0.34 mm <sup>2</sup>
Strip length	6 ... 7 mm / 0.24 ... 0.28 inches
Conductor connection direction to PCB	0°
Pole number	2

## Physical data

Pin spacing	4 mm / 0.157 inches
Width	7.9 mm / 0.311 inches
Height	6.9 mm / 0.272 inches
Height from the surface	4.5 mm / 0.177 inches
Depth	12.7 mm / 0.5 inches
Solder pin length	2.4 mm
Solder pin dimensions	1.2 x 0.75 mm
Plated through-hole diameter (THR)	1.5 <sup>(+0.1)</sup> mm
Reel diameter of tape-and-reel packaging	330 mm
Tape width	24 mm

### PCB contact

PCB contact	THR
Solder pin arrangement	over the entire terminal strip (in-line)
Number of solder pins per potential	2

### Material data

Note (material data)	<a href="#">Information on material specifications can be found here</a>
Color	white
Material group	I
Insulation material (main housing)	Polyphthalamide (PPA GF)
Flammability class per UL94	V0
Clamping spring material	Copper alloy
Contact material	Copper alloy
Contact Plating	Tin
Fire load	0.003 MJ
Weight	0.5 g
MSL per J-STD 020D	1

### Environmental requirements

Limit temperature range	-60 ... +105 °C
-------------------------	-----------------

### Commercial data

PU (SPU)	6750 (750) pcs
Packaging type	Box
Country of origin	CN
GTIN	4055143331203
Customs tariff number	85369010000

### Product Classification

UNSPSC	39121409
eCl@ss 10.0	27-14-11-06
eCl@ss 9.0	27-14-11-06
ETIM 9.0	EC001284
ETIM 10.0	EC001284
ECCN	NO US CLASSIFICATION

### Environmental Product Compliance

RoHS Compliance Status	Compliant, No Exemption
------------------------	-------------------------

### Approvals / Certificates

#### General approvals



Approval	Standard	Certificate Name
CCA DEKRA Certification B.V.	EN 60838	NTR NL 2168246

#### General approvals

cURus Underwriters Laboratories Inc.	UL 1977	E45171
KEMA/KEUR DEKRA Certification B.V.	EN 60838	2168246.01
KEMA/KEUR DEKRA Certification B.V.	EN 60947	71-108183
KEMA/KEUR DEKRA Certification B.V.	EN 60998	71-109040
KEMA/KEUR DEKRA Certification B.V.	EN 60947-7-4	71-114208

**General approvals**

UL	UL 1059	E45172
Underwriters Laboratories Inc.		

**Declarations of conformity and manufacturer's declarations**

Approval	Standard	Certificate Name
EU-Declaration of Conformity WAGO GmbH & Co. KG	-	-
UK-Declaration of Conformity WAGO GmbH & Co. KG	-	-

**Downloads**

**Environmental Product Compliance**

Compliance Search	
Environmental Product Compliance 2060-1452/998-404	<a href="#">↓</a>

**Documentation**

Additional Information			
Technical Section	03.04.2019	pdf 2027.26 KB	<a href="#">↓</a>
		pdf 535.32 KB	<a href="#">↓</a>

**CAD/CAE-Data**

CAD data
2D/3D Models 2060-1452/998-404

CAE data
ZUKEN Portal 2060-1452/998-404

**PCB Design**

Symbol and Footprint via SamacSys 2060-1452/998-404	<a href="#">↓</a>
Symbol and Footprint via Ultra Librarian 2060-1452/998-404	<a href="#">↓</a>

## 1 Compatible Products

### 1.1 Optional Accessories

#### 1.1.1 Ferrule

##### 1.1.1.1 Ferrule



**Item No.: 216-131**

Ferrule; Sleeve for 0.25 mm<sup>2</sup> / AWG 24; uninsulated; electro-tin plated; silver-colored

**Item No.: 216-132**

Ferrule; Sleeve for 0.34 mm<sup>2</sup> / 22 AWG; uninsulated; electro-tin plated

### 1.1.2 Tool

#### 1.1.2.1 Operating tool



**Item No.: 206-860**

Operating tool; for 2060 Series; multi-colored



**Item No.: 2060-189**

Operating tool; made of insulating material; for 2060 Series; white

## Installation Notes

### Conductor termination



Insert solid conductors via push-in termination.

### Conductor termination



Insert/remove fine-stranded conductors by lightly pressing on push-button, e.g., via optional operating tool (206-860).