

Verpackt im Gurt in Anlehnung an DIN IEC 60286-3
 tape on reel packaging according to DIN IEC 60286-3
 Verpackungseinheit: 400 Stück
 packaging unit: 400 pcs

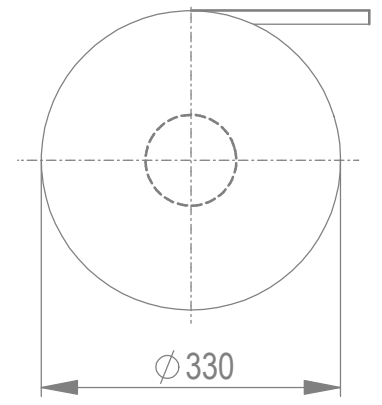

Abspulrichtung - reel off direction

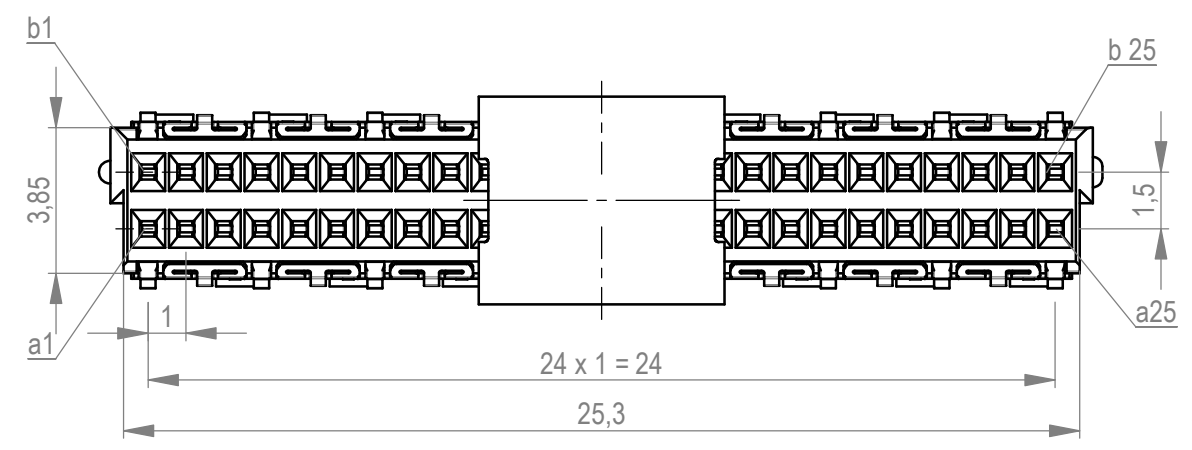
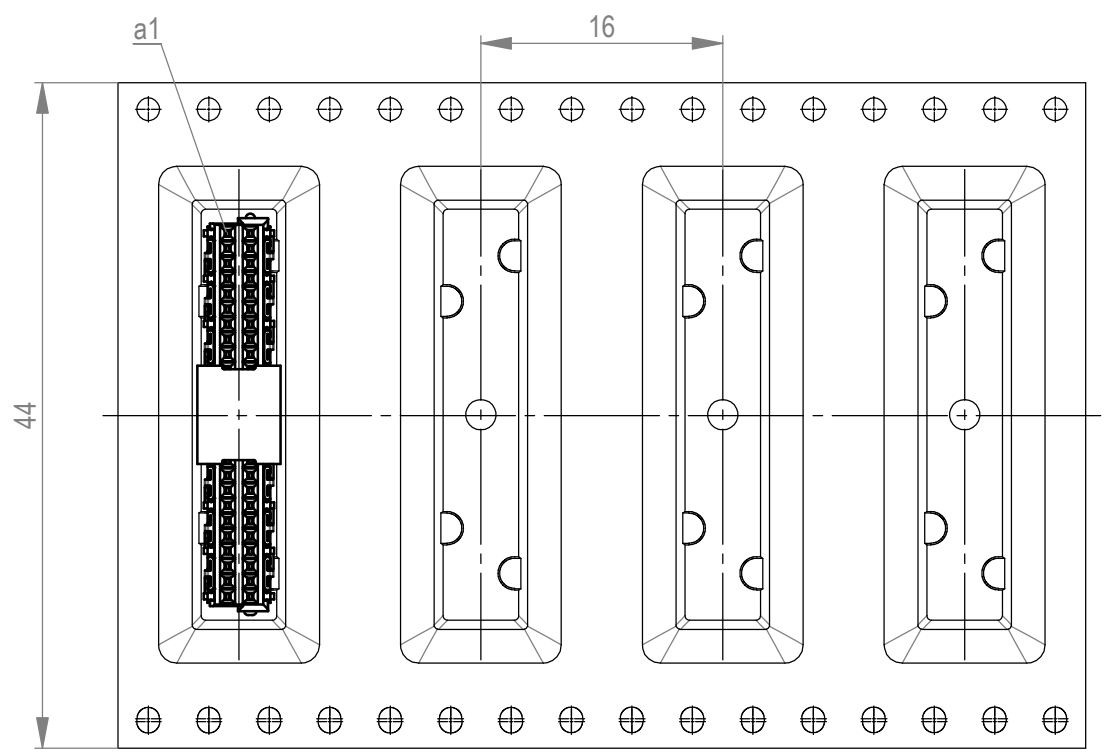

- Anforderungsstufe 1
performance level 1
- Kontaktbereich vergoldet
mating area gold plating
- Anschlussbereich verzinkt 4-6 µm
terminal area 4-6 µm tin plating
- Koplanarität der Anschlüsse ≤ 0,1 mm
coplanarity area of termination ≤ 0,1 mm

Leiterplatten-Layout Vorschlag
 PCB-Layout Proposal

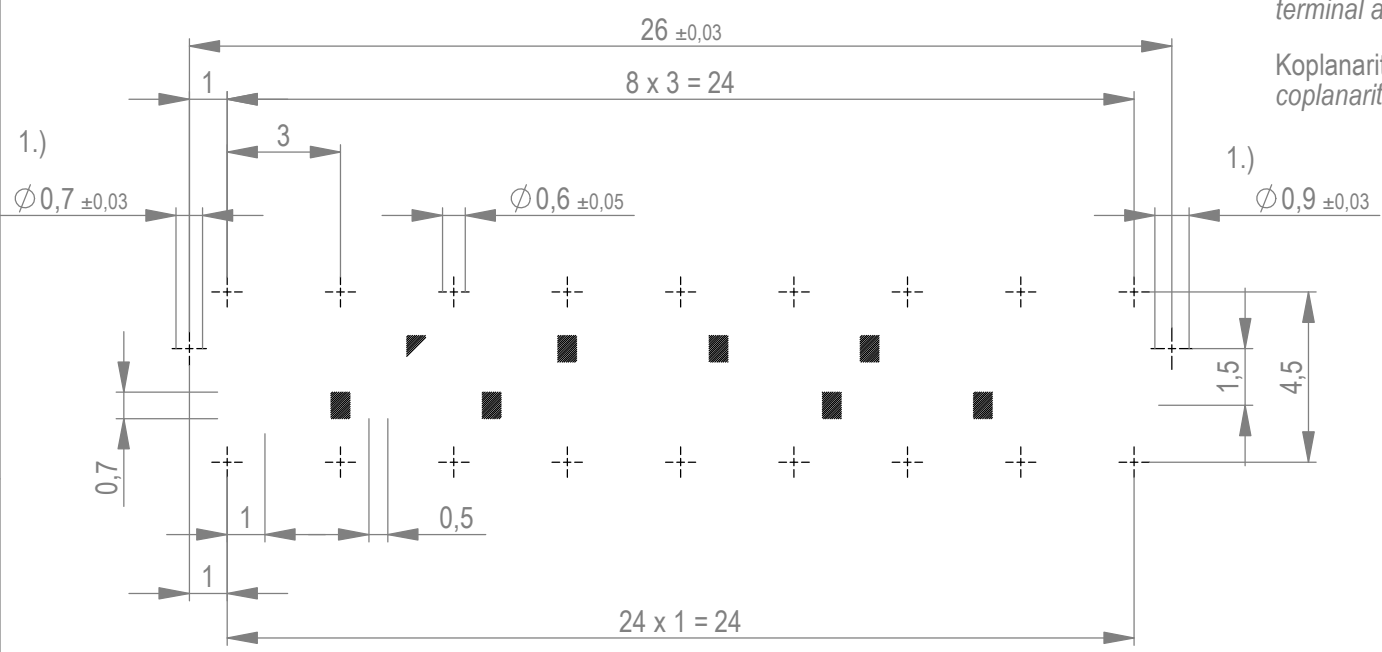

1.) Durchmesser des Bohrers / Drill tool

Weitergabe sowie Vervielfältigung dieses Dokuments, Verwertung und Mitteilung seines Inhalts sind verboten, soweit nicht ausdrücklich gestattet. Zuwiderhandlungen verpflichten zu Schadenersatz. Alle Rechte für den Fall der Patent-, Gebrauchsmuster- oder Geschmacksmustererhaltung vorbehalten. The reproduction, distribution and utilization of this document as well as the communication of its contents to others without express authorization is prohibited. Offenders will be held liable for the payment of damages. All rights reserved in the event of the grant of a patent, utility model or design.

Die deutsche Version dieser Zeichnung dient nur zur Erleichterung der Handhabung. Bei Abweichungen von dem englischen Original gilt das englische Original. The german version of this drawing has been offered for convenience only and may deviate from the english original. In case of any deviation the English version shall prevail.

Dimension no.	Tolerances		Scale	5:1
	ISO 8015	All Dimensions in mm	Material	
Customer drawing:	This Drawing is a controlled Document.		Subject to modification without prior notice. Drawing will not be updated.	
j1	18.05.2023			
Index	Date			
			Federleiste 4mm THR, 50 polig Female 4mm THR, 50 contacts C-144663-E	
			Class	MSPEED
				c A3