

THE INFORMATION CONTAINED HEREIN IS CONSIDERED "PROPRIETARY" TO BEL FUSE INC. AND SHALL NOT BE COPIED, REPRODUCED OR DISCLOSED WITHOUT THE WRITTEN APPROVAL OF BEL FUSE INC.

PRELIMINARY

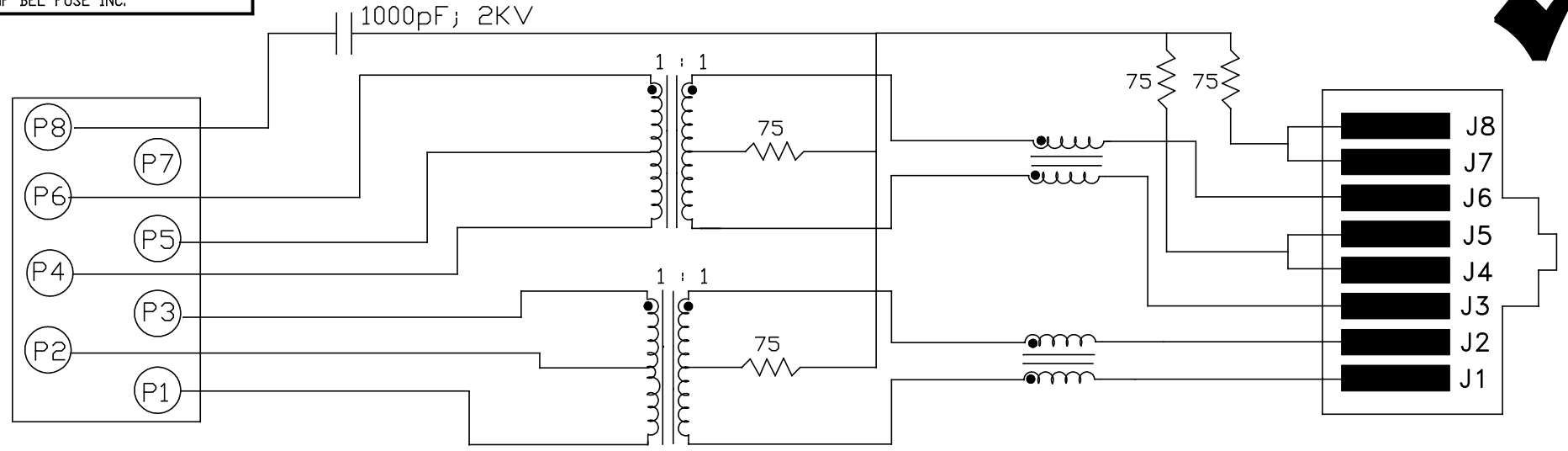

ELECTRICAL SPECIFICATIONS:

- 1.0 TURNS RATIO: (P6-P5-P4) : (J6-J3) : 1CT : 1CT ± 3%  
(P3-P2-P1) : (J2-J1) : 1CT : 1CT ± 3%
- 2.0 INDUCTANCE: (P6-P4) : 350uH MIN. @ 0.1V, 100KHz, 8mA DC Bias  
(P3-P1) : 350uH MIN. @ 0.1V, 100KHz, 8mA DC Bias
- 3.0 LEAKAGE INDUCTANCE: P6-P4 (WITH J6 AND J3 SHORT) : 0.3 MAX. @ 1MHz  
P3-P1 (WITH J2 AND J1 SHORT) : 0.3 MAX. @ 1MHz
- 4.0 INTERWINDING CAPACITANCE: (P6,P5,P4) TO (J6,J3) : 30pf MAX. @ 1MHz  
(P3,P2,P1) TO (J2,J1) : 30pf MAX. @ 1MHz
- 5.0 DC RESISTANCE: (J6-J3)=(J2-J1) : 1.2 ohms Max.

NOTES

1.0 PINS WITHOUT ELECTRICAL CONNECTION ARE OMITTED.

|   |  |   |   |      |  |                  |   |  |
|---|--|---|---|------|--|------------------|---|--|
| <b>ORIGINATED BY</b><br>CHOW WANCHUNG<br><b>DATE</b> 2018-01-31 |  | <b>TITLE</b><br><br>10/100BT MagJack®<br>TAB DOWN, SHIELDED | <b>PART NO. / DRAWING NO.</b><br>SI-60002-F |      | <b>STANDARD DIM. TOL. IN INCH</b> [ ] <b>METRIC DIM. AS REF.</b> |                  | <b>REV. :</b> PA <b>PAGE :</b> 2  |  |
| <b>DRAWN BY</b><br>XIE YIMING<br><b>DATE</b> 2018-01-31         |  |   | <b>FILE NAME</b><br>SI-60002-F_PA.DWG       |      | .X   | UNIT : INCH [mm] |  |  |
|   |  |   |   |      | .XX  | SCALE : N/A      |   |  |
|   |  |   |   | .XXX | SIZE : A4  |                  |   |  |

DC002(2)120214

This document is electronically generated. This is a controlled copy if used internally

THE INFORMATION CONTAINED HEREIN IS CONSIDERED "PROPRIETARY" TO BEL FUSE INC. AND SHALL NOT BE COPIED, REPRODUCED OR DISCLOSED WITHOUT THE WRITTEN APPROVAL OF BEL FUSE INC.

PRELIMINARY



RECEIVE

6.0 RETURN LOSS: 1MHz TO 30MHz : 18dB MIN.  
 60MHz TO 80MHz : 12dB MIN.

NOTE: 100 OHMS CONNECTED TO (J2-J1) OR (J6-J3).

7.0 DIELECTRIC WITHSTAND: (J1, J2) TO (P1, P3) : 1500 VAC  
 (J3, J6) TO (P4,P6) : 1500 VAC

8.0 INSERTION LOSS: RS=RL=100 ohms : 1.1 dB TYP  
 100KHz TO 100MHz

9.0 RISE TIME: RS=100 OHMS AND RL = 100 OHMS : 3.0 nS MAX  
 OUTPUT VOLTAGE = 1 V peak : 3.0 nS MAX  
 PULSE WIDTH= 112nS

10.0 CROSS TALK: 1MHz TO 100MHz : 40 dB TYP

11.0 COMMON TO COMMON MODE ATTENUATION: 30MHz TO 100MHz : 35dB TYP

|   |  |  |                                      |           |   |  |           |          |
|---|--|--|--------------------------------------|-----------|---|--|-----------|----------|
| ORIGINATED BY<br>CHOW WANCHUNG<br>DATE 2018-01-31 |  | TITLE<br>10/100BT MagJack®<br>TAB DOWN, SHIELDED | PART NO. / DRAWING NO.<br>SI-60002-F |           | STANDARD DIM. [ ] METRIC DIM.<br>TOL. IN INCH AS REF. |  | REV. : PA | PAGE : 3 |
| DRAWN BY<br>XIE YIMING<br>DATE 2018-01-31         |  |  | FILE NAME<br>SI-60002-F_PA.DWG       |           | UNIT : INCH [mm]                                      |  |           |          |
|   |  |  |                                      |           | SCALE : N/A   |  |           |          |
|   |  |  |                                      | SIZE : A4 |   |  |           |          |

DC002(2)120214

This document is electronically generated. This is a controlled copy if used internally

THE INFORMATION CONTAINED HEREIN IS CONSIDERED "PROPRIETARY" TO BEL FUSE INC. AND SHALL NOT BE COPIED, REPRODUCED OR DISCLOSED WITHOUT THE WRITTEN APPROVAL OF BEL FUSE INC.

PRELIMINARY



NOTES:

- CONNECTOR MATERIALS:  
HOUSING: THERMOPLASTIC UL94 V-0  
CONTACT/SHIELD: COPPER ALLOY  
SHIELD PLATING: NICKEL OR TIN  
CONTACT PLATING: SELECTIVE GOLD,  
50 MICRO-INCHES MIN. IN CONTACT AREA.
- PIN NOT ELECTRICALLY CONNECTED MAYBE OMITTED.  
SEE ELECTRICAL DRAWING FOR OMITTED PINS.
- TOLERANCES COMPLY WITH F.C.C. DIMENSION REQUIREMENTS.
- THE PRODUCT IS RoHS COMPLIANT.
- THE PART IS RECOMMENDED FOR WAVE SOLDERING.  
THE SUGGESTED PEAK WAVE SOLDERING CONDITION IS 260°C MAX  
AND 10 SECONDS MAX.

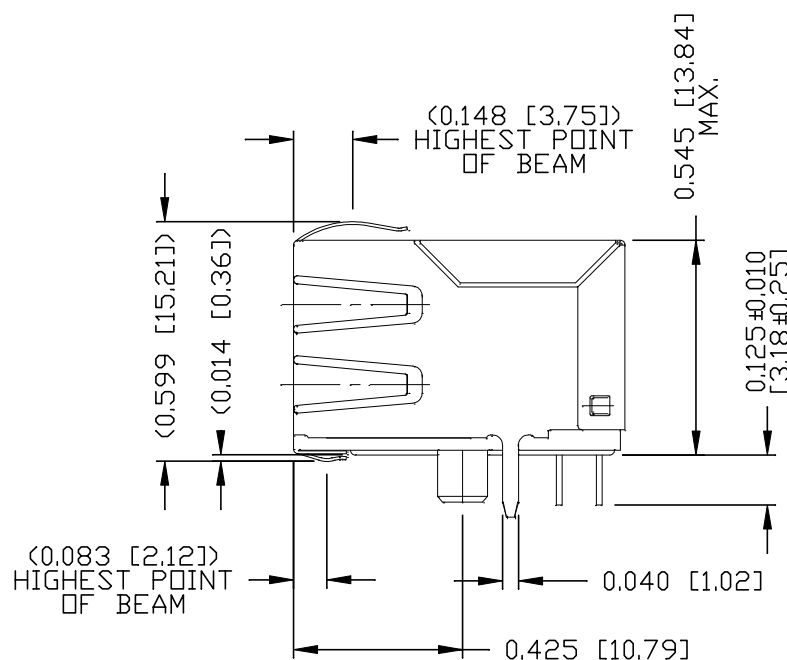
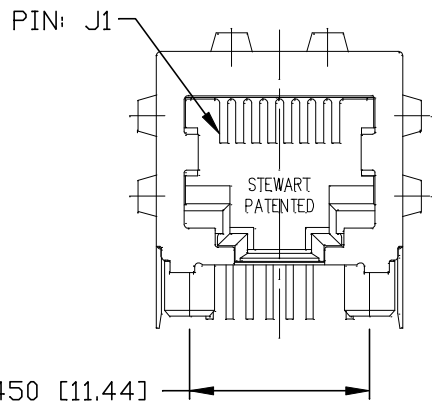
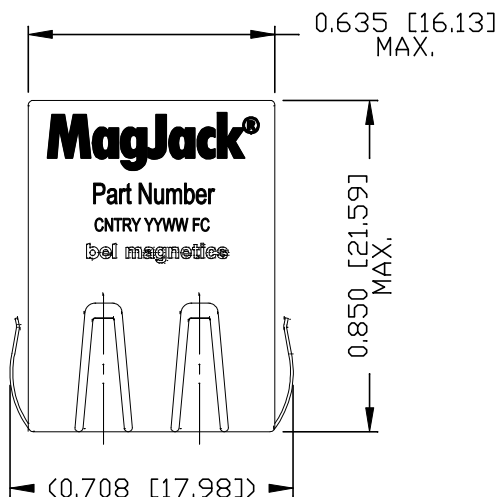

REV. : PA PAGE : 4

ORIGINATED BY  
ANTON LIAO  
DATE 2018-01-31  
DRAWN BY  
LIU DONGJUN  
DATE 2018-01-31

TITLE  
10/100BT MagJack®  
TAB DOWN, SHIELDED

PART NO. / DRAWING NO.  
SI-60002-F  
FILE NAME  
SI-60002-F\_PA.DWG

| STANDARD DIM. TOL. IN INCH | [ ] METRIC DIM. AS REF. |
|----------------------------|-------------------------|
| .X                         | UNIT : INCH [mm]        |
| .XX                        | SCALE : N/A             |
| .XXX                       | ±0.005                  |
|                            | SIZE : A4               |



THE INFORMATION CONTAINED HEREIN IS CONSIDERED "PROPRIETARY" TO BEL FUSE INC. AND SHALL NOT BE COPIED, REPRODUCED OR DISCLOSED WITHOUT THE WRITTEN APPROVAL OF BEL FUSE INC.

PRELIMINARY

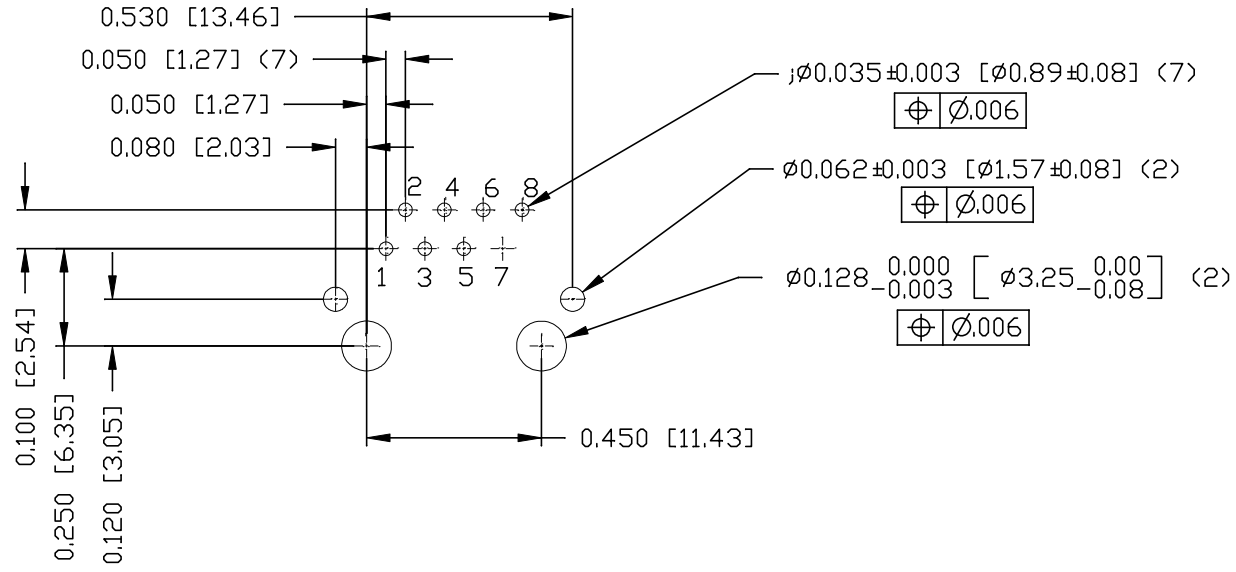

PCB RECOMMENDED HOLE LAYOUT  
 (SEEN FROM COMPONENT SIDE)  
 ALL CENTERLINE DIMENSIONS ARE BASIC

|  |  |   |   |                   |   |  |                  |                 |
|--|--|---|---|-------------------|---|--|------------------|-----------------|
| <b>ORIGINATED BY</b><br>ANTON LIAO<br><b>DATE</b> 2018-01-31 |  | <b>TITLE</b><br>10/100BT MagJack®<br>TAB DOWN, SHIELDED | <b>PART NO. / DRAWING NO.</b><br>SI-60002-F |                   | <b>STANDARD DIM. TOL. IN INCH</b> [ ] METRIC DIM. AS REF. |  | <b>REV. :</b> PA | <b>PAGE :</b> 5 |
| <b>DRAWN BY</b><br>LIU DONGJUN<br><b>DATE</b> 2018-01-31     |  |   | <b>FILE NAME</b><br>SI-60002-F_PA.DWG       | .X<br>.XX<br>.XXX | UNIT : INCH [mm]<br>SCALE : N/A<br>SIZE : A4              |  |                  |                 |
|  |  |   |   | ±0.005            |   |  |                  |                 |

DC002(2)120214

This document is electronically generated. This is a controlled copy if used internally

THE INFORMATION CONTAINED HEREIN IS CONSIDERED "PROPRIETARY" TO BEL FUSE INC. AND SHALL NOT BE COPIED, REPRODUCED OR DISCLOSED WITHOUT THE WRITTEN APPROVAL OF BEL FUSE INC.

SUGGESTED PANEL OPENING

PRELIMINARY

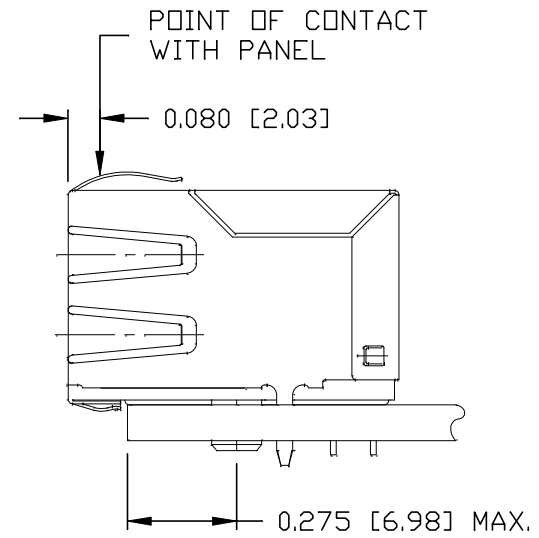
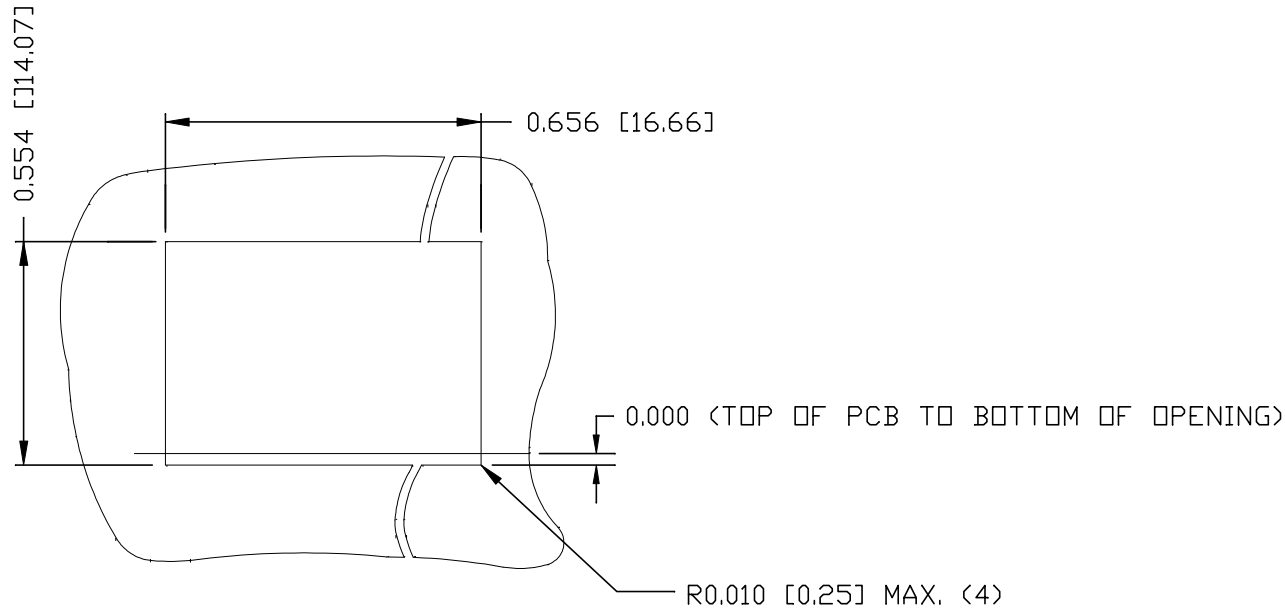

NOTES:

THE SUGGESTED PANEL OPENING IS INTENDED TO GIVE THE USER THE ABILITY TO HAVE REASONABLE JACK / PANEL CLEARANCES YET MAINTAIN RELIABLE GROUNDING CAPABILITY.

|  |  |   |  |   |  |   |
|--|--|---|--|---|--|---|
| <b>ORIGINATED BY</b><br>ANTON LIAO<br><b>DATE</b> 2018-01-31<br><b>DRAWN BY</b><br>LIU DONGJUN<br><b>DATE</b> 2018-01-31 |  | <b>TITLE</b><br><br>10/100BT MagJack®<br>TAB DOWN, SHIELDED | <b>PART NO. / DRAWING NO.</b><br>SI-60002-F<br><b>FILE NAME</b><br>SI-60002-F_PA.DWG | <b>STANDARD DIM. TOL. IN INCH</b><br>.X<br>.XX<br>.XXX ±0.005 | <b>[ ] METRIC DIM. AS REF.</b><br>UNIT : INCH [mm]<br>SCALE : N/A<br>SIZE : A4 | <b>REV. :</b> PA <b>PAGE :</b> 6<br> |
|--|--|---|--|---|--|---|

DC002(2)120214

This document is electronically generated. This is a controlled copy if used internally