

Plastic Push-Pull Lock Connectors

RP13 Series

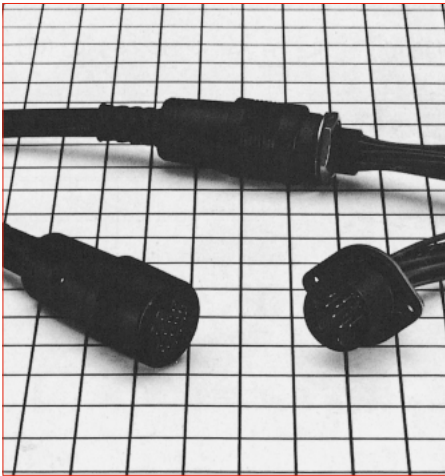

■ Features

1. Superior mating operability

- A secure mating condition is achieved by simply pushing the plug on to the receptacle; Pull back on the locking sleeve to easily un-mate the connector.
- Index marks are provided on the plug for easy mating alignment.
- Our proprietary guide keys aid with making a correct mating orientation in blind or low light conditions.

2. Light weight and robust design

The strong outer shell is made of glass-reinforced polycarbonate resin, producing light but durable connectors.

3. Available in an anti-static version

The metal plates in the receptacle protect the signal lines from static electricity.

4. Variation

Items	
Number of contacts	13, 20
Connector type	Plug and jack: Straight, Receptacle: Straight, right angle
Plug termination type	Crimp
Receptacle termination type	Crimp, PCB dip
Receptacle mounting style	Flange, jam nut

■ Product Specifications

Ratings	Rated current	Standard type : 2A (when using a wire of at least 24 AWG) Anti-static type : 2A (when using a wire of at least 22 AWG)	Operating temperature range	-10 to +60°C
	Rated voltage	For 13 contact positions : AC 100V, DC 140V 20 contacts : AC 100V, DC 140V or AC 30V, DC 42V	Storage temperature range	-10 to +60°C

Items	Specifications	Conditions
1. Contact resistance	For 13 contact positions : 15mΩ max. 20 contacts : 30mΩ max.	Measured at DC 1A
2. Insulation resistance	1,000MΩ min.	Measured at DC 250V
3. Withstanding voltage	No flashover or dielectric breakdown.	AC 300V for 1 minute
4. Vibration resistance	No electrical discontinuity for 10μs or greater.	10 to 55Hz/cycle, amplitude : 0.75mm, 3 axis directions, 2 hours each
5. Shock resistance	No electrical discontinuity for 10μs or greater.	Acceleration : 490m/s ² , duration : 11ms, 3 axis directions, 3 cycles each
6. Mating cycles	Contact resistance : For 13 contact positions : 20mΩ max. For 20 contact positions : 45mΩ max.	1,000 times
7. Temperature cycle	Insulation resistance : 100MΩ min.	-55°C : 30 minutes → Normal temperature : 10 to 15 minutes → 85°C : 30 minutes → Normal temperature : 10 to 15 minutes, leave total 5 cycles
8. Moisture resistance	Insulation resistance : 10MΩ min. (at high humidity) 100MΩ min. (when dry)	Temperature : 40°C, relative humidity : 90 to 95%, leave 96 hours

■ Materials / Finish

Items	Material	Finish	
Plug	Exterior, insulator	Polycarbonate resin	
	Clamp	Brass	
	Bushing	Vinyl chloride resin	
Receptacle	Exterior, insulator	Polycarbonate resin	
		PBT resin	
		Steel	Nickel plating
	Female contact	Phosphor bronze	Silver plating
	Male contact	Brass	
Crimp contact	Female contact	Phosphor bronze	Silver plating, gold plating
Crimp contact	Male contact		

■ Product Number Structure

Refer to the chart below when determining the product specifications from the product number.
Please select from the product numbers listed in this catalog when placing orders.

● Plug

RP13A - 12 P A - 13 S C (01)

①
②
③
④
⑤
⑥
⑦
⑧

<p>① Model name : RP13A Series</p>	<p>⑥ Contact form S : Female contact P : Male contact</p>
<p>② Shell size : The shell size is the outer diameter of the mating end of the plug.</p>	<p>⑦ Contact termination type: A : Straight, PCB dip B : Right-angle, PCB dip C : Contact termination by crimping</p>
<p>③ Shell type P : Straight plug R : Receptacle J : Jack</p>	<p>⑧ Other specifications : A two-digit character is added to indicate other specifications as needed.</p>
<p>④ Shell variation : Connectors are distinguished by A, B, or C if a variation is made within the series.</p>	
<p>⑤ Number of contacts</p>	

● Crimp contact

RP13A - SC - 2 1 1

①
⑨
⑩
⑪
⑫

<p>① Model name : Indicates the series name. RP13, RP13A, RP19</p>	<p>⑪ Barrel form : RP13, RP13A 1 : For 18 to 22 AWG 2 : For 24 to 28 AWG RP19 For 24 to 30 AWG</p>
<p>⑨ Contact type : SC : Socket type crimp contact (female) PC : Pin type crimp contact (male)</p>	<p>⑫ Identification of plating : 1 : Gold plating 2 : Silver plating</p>
<p>⑩ Contact form : 1 : Loose piece contacts 2 : Reel contacts</p>	

■ Standard type

● Standard plug

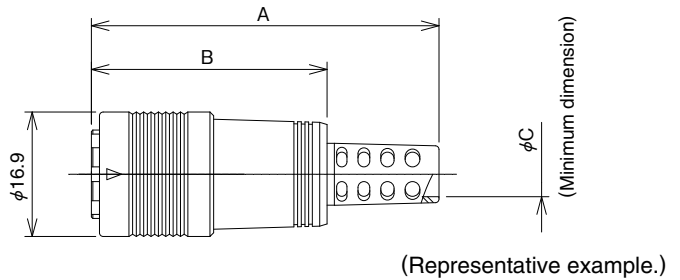

Part No.	HRS No.	No. of contacts	A	B	φC	Weight	Part No.	HRS No.	No. of contacts	A	B	φC	Weight		
RP13A-12PA-13SC(71)	113-0182-4 71	13	47.2	32	6.1	6.0g	RP13A-12PD-20SC(71)	113-0214-9 71	20	52.2	37	6.1	6.0g		
RP13A-12PB-13SC(31)	113-0184-0 31				5.7			RP13A-12PG-20SC(71)		113-0210-8 71				7.5	
RP13A-12PD-13SC(71)	113-0186-5 71		52.2	37	6.1		47.2	32		6.4					
RP13A-12PE-13SC(71)	113-0201-7 71		47.2	32	6.4		52.2	37		7.1					
RP13A-12PK-13SC(71)	113-1006-7 71				7.1					8.1					
RP13A-12PS-13SC(71)	113-1026-4 71		52.2	37	8.1										

(Note) Cable clamping, cable rotation, and other forces may vary with the cable construction. Please make sure that your cable is suitable for use with these connectors before usage and production.

● Receptacle (Flange type)

(Crimp type)

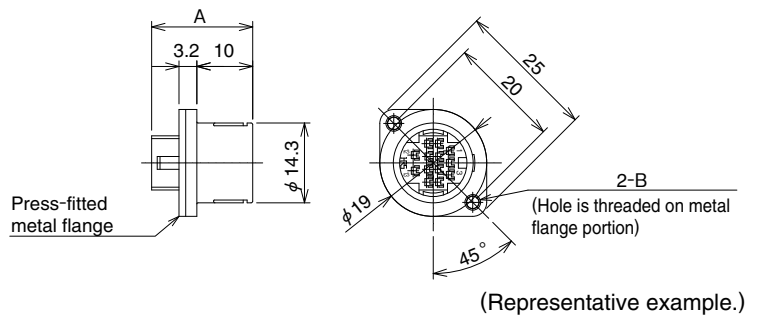

Part No.	HRS No.	No. of contacts	A	B	Weight
RP13A-12RA-13PC(71)	113-0183-7 71	13	18.1	M2.6×0.45	4.0g
RP13A-12RA-20PC(71)	113-0215-1 71	20	16		

(Remarks) See page 5 for details on mounting hole dimensions.

(Dip type)

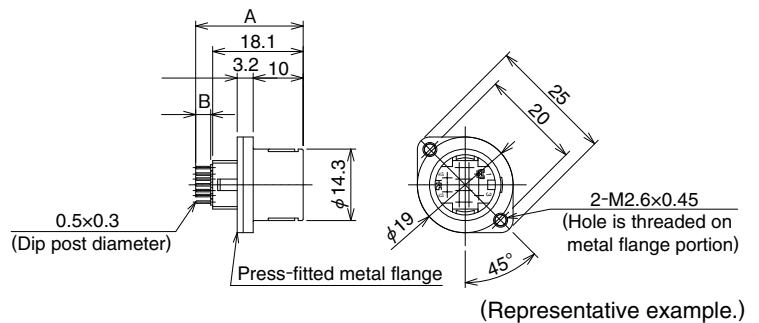

Part No.	HRS No.	No. of contacts	A	B	Weight
RP13A-12RA-13PA(71)	113-0202-0 71	13	21.5	3	5.0g

(Remarks) See page 5 for details on mounting dimensions and page 7 for details on dip post arrangement sizes.

● Receptacle (Jam nut to be fastened)

(Dip type)

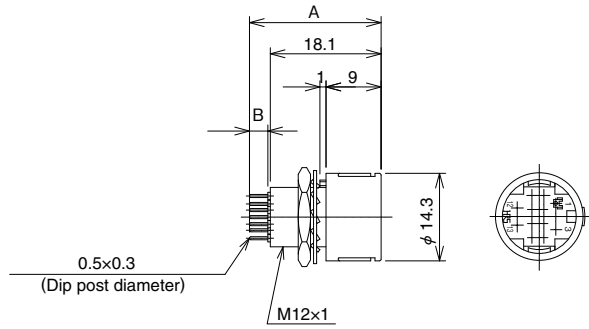

Part No.	HRS No.	A	B	No. of contacts	Weight
RP13A-12RB-13PA(71)	113-0203-2 71	21.5	3	13	3.5g

(Remarks) See page 5 for details on mounting hole dimensions and page 7 for details on dip post arrangement sizes.

● Right-angle, dip type

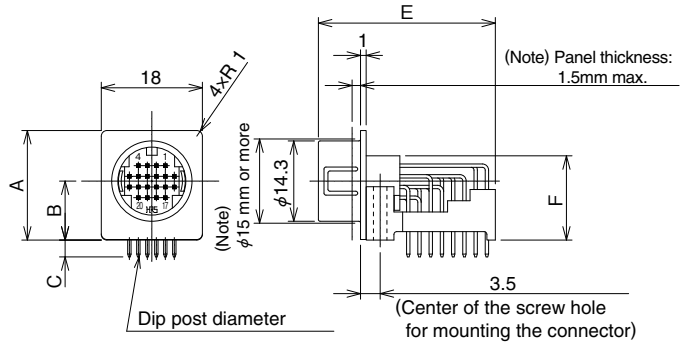

(Note) The mounting panel thickness should be 1.5mm or less. Mounting hole should be φ15 mm or more.

Part No.	HRS No.	No. of contacts	A	B	C	φD	E	F	Weight
RP13A-12RC-13PB	113-1020-8	13	17.5	8.5	3.5	0.64	23.5	13	4.0g
RP13A-12RC-20PB	113-0211-0	20	19.5	10.5	3	0.6	31.5	15	5.0g

(Remarks) See page 7 for details on dip post arrangement sizes.

● Jack

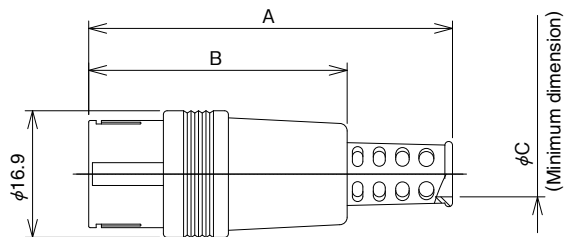

(Representative example.)

Part No.	HRS No.	No. of contacts	A	B	φC	Weight
RP13A-12J-13PC(71)	113-0166-8 71	13	49.1	34.6	6.1	4.5g
RP13A-12JG-20PC(71)	113-1004-1 71	20	52.6	37.4	7.4	

(Note) Cable clamping, cable rotation, and other forces may vary with the cable construction. Please make sure that your cable is suitable for use with these connectors before usage and production.

◆ **Contact**

(Male contact)

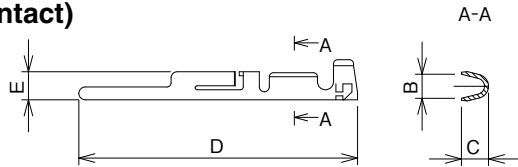

(Representative example.)

For 13 contact positions

Type	Part No.	HRS No.	Plating	B	C	D	E	Applicable wire size
Loose piece contacts	RP13-PC-122	113-0179-0	Silver plating	1.2	1.35	13.9	1.4	24 to 28 AWG
Reel contacts	RP13-PC-221	113-0360-0	Partial gold plating					
	RP13-PC-222	113-0141-7	Silver plating					

13 contact position for super-thick wires (available for contact position numbers 12 and 13 only)

Type	Part No.	HRS No.	Plating	B	C	D	E	Applicable wire size
Loose piece contacts	RP13-PC-112	113-0178-7	Silver plating	1.6	2.1	13.9	1.4	18 to 22 AWG
Reel contacts	RP13-PC-212	113-0140-4						

For 20 contact positions

Type	Part No.	HRS No.	Plating	B	C	D	E	Applicable wire size
Loose piece contacts	RP19-PC-122	113-0268-8	Silver plating	1.2	1.35	12	1.18	24 to 30 AWG
Reel contacts	RP19-PC-222	113-0264-7						

(Female contact)

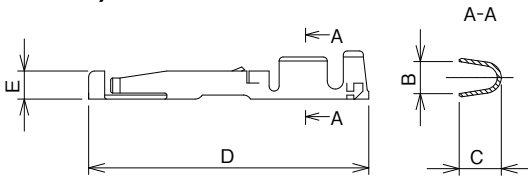

(The form shown above represents an example.)

For 13 contact positions

Type	Part No.	HRS No.	Plating	B	C	D	E	Applicable wire size
Loose piece contacts	RP13A-SC-121	113-0363-9	Partial gold plating	1.2	1.35	13.9	1.4	24 to 28 AWG
	RP13A-SC-122	113-0181-1	Silver plating					
Reel contacts	RP13A-SC-221	113-0362-6	Partial gold plating					
	RP13A-SC-222	113-0151-0	Silver plating					

13 contact position for super-thick wires (available for contact position numbers 12 and 13 only)

Type	Part No.	HRS No.	Plating	B	C	D	E	Applicable wire size
Loose piece contacts	RP13A-SC-112	113-0180-9	Silver plating	1.6	2.1	13.9	1.4	18 to 22 AWG
Reel contacts	RP13A-SC-212	113-0150-8						

For 20 contact positions

Type	Part No.	HRS No.	Plating	B	C	D	E	Applicable wire size
Loose piece contacts	RP19-SC-122	113-0270-0	Silver plating	1.2	1.35	11	1.18	24 to 30 AWG
Reel contacts	RP19-SC-222	113-0266-2						

(Note 1) Use connectors with gold-plated contacts if the connectors will be subjected to constant vibration.

(Note 2) Loose piece contacts are available in 100 piece packs. Reel contacts are available as 10,000 piece reels.

◆ **Panel mounting hole dimensions**

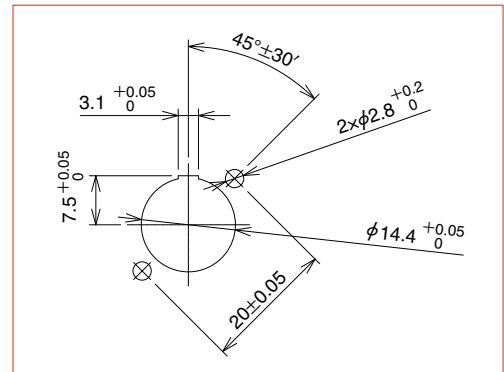

(Flange type)

● **Applicable connector**

Part No.	HRS No.
RP13A-12RA-13PC(71)	113-0183-7 71
RP13A-12RA-13PA(71)	113-0202-0 71
RP13A-12RA-20PC(71)	113-0215-1 71

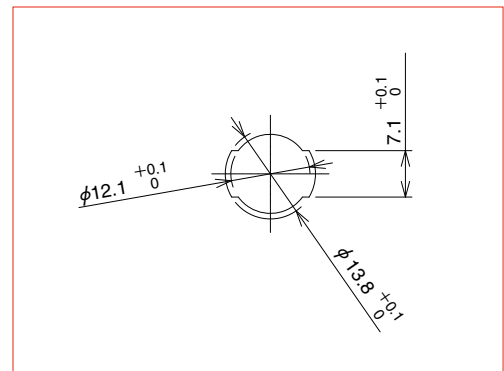

(Jam nut to be tightened)

● **Applicable connector**

Part No.	HRS No.
RP13A-12RB-13PA(71)	113-0203-2 71

(Note 1) Above figures show the arrangement viewed from the panel surface. The mating guide of flange type is located on the top position.

(Note 2) The applicable panel thickness for the flange type receptacle is 2.7mm max., since this type is mounted from the back surface of the panel.

(Note 3) The applicable panel thickness for a hex nut fastening type is 5mm max. and 1mm min.

■ RP13A anti-static type

● Plug

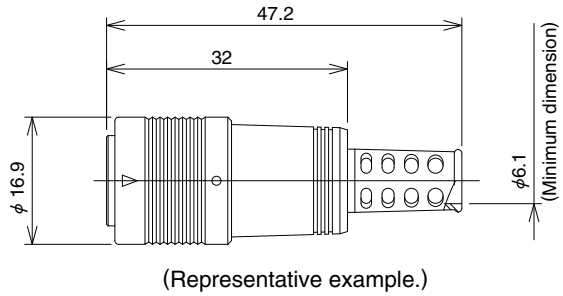

Part No.	HRS No.	No. of contacts	Weight
RP13A-12PA-13PC(71)	113-4003-5 71	13	6.0g

(Note) Cable clamping, cable rotation, and other forces may vary with the cable construction. Please make sure that your cable is suitable for use with these connectors before usage and production.

● Receptacle (flange type)

(Crimp type)

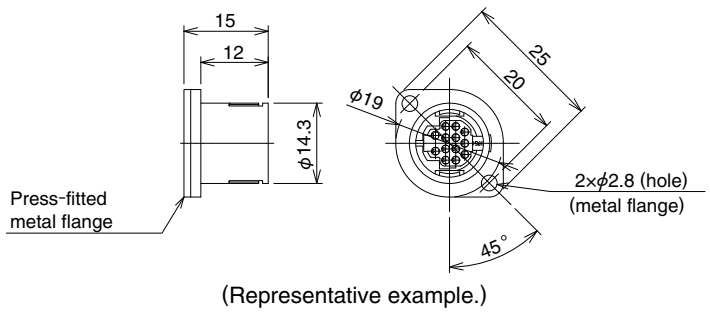

Part No.	HRS No.	No. of contacts	Weight
RP13A-12R-13SC(71)	113-4002-2 71	13	4.0g

(Remarks) See page 7 for details on mounting hole dimensions.

◆ Contact

(Male contact)

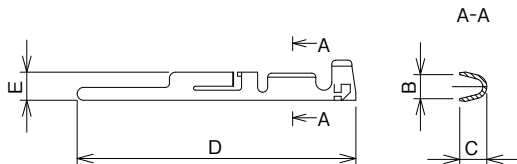

(Female contact)

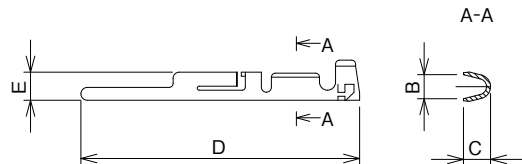

Type	Part No.	HRS No.	B	C	D	E	Applicable wire size
Loose piece contacts	RP19-PC-122	113-0268-8	1.2	1.35	12	1.18	24 to 30 AWG
Reel contacts	RP19-PC-222	113-0264-7					

Type	Part No.	HRS No.	B	C	D	E	Applicable wire size
Loose piece contacts	RP19-SC-122	113-0270-0	1.2	1.35	11	1.18	24 to 30 AWG
Reel contacts	RP19-SC-222	113-0266-2	1.2	1.35			

(Note) Loose piece contacts are available in 100 piece packs. Reel contacts are available as 10,000 piece reels.

◆ Panel mounting hole dimensions (for anti-static type)

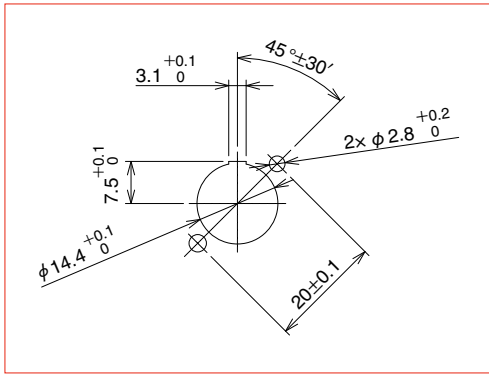

(Flange type)

(Note 1) Above figures show the arrangement viewed from the panel surface. The mating guide of flange type is located on top the position.

(Note 2) The applicable panel thickness for a flange type receptacle is maximum 4.7mm, as this type is mounted from the back surface of the panel.

◆ Dip post arrangement sizes for receptacles

● Straight dip type

13 contacts

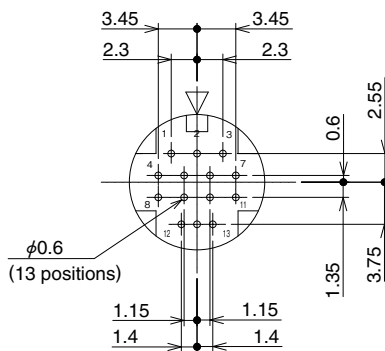

(Remarks) 1. The figure shown above for 13 contact positions is viewed from the receptacle mating end.

2. A machining tolerance of ± 0.05 is recommended for the PCB layout dimensions.

● Right-angle, dip type

13 contacts

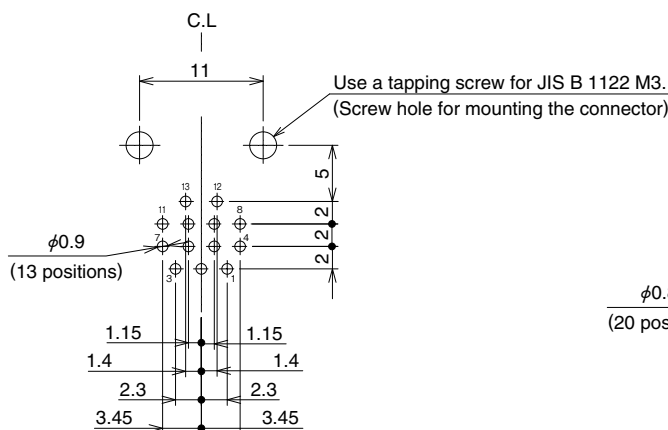

20 contacts

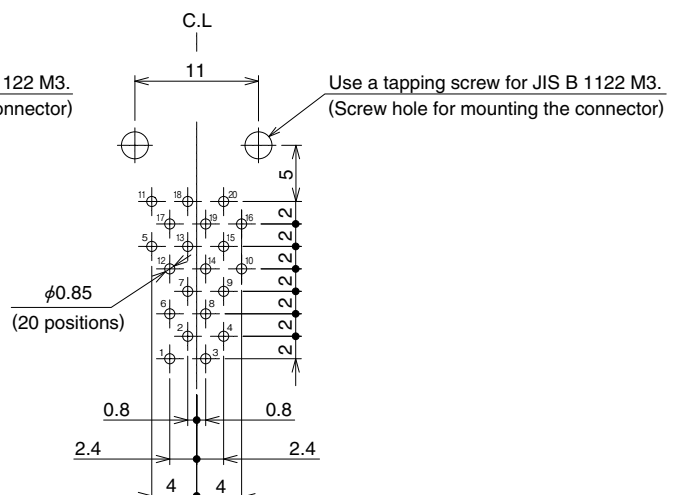

(Remarks) 1. The figures shown above are viewed from the contact insertion end.

2. A machining tolerance of ± 0.05 mm is recommended for the PCB layout dimensions.

◆ Applicable tools

Type	Items	Part No.	HRS No.	Applicable contact	Applicable wire size and applicable cable diameter
Manual	Manual crimping tool	RP13-TC-11	150-0024-3	RP13-PC-112	18 to 22 AWG
		RP13-TC-12	150-0025-6	RP13-PC-121, 122	24 to 28 AWG
		RP13A-TC-11	150-0026-9	RP13A-SC-112	18 to 22 AWG
		RP13A-TC-12	150-0027-1	RP13A-SC-121, 122	24 to 28 AWG
		RP19-TC-12	150-0049-4	RP19-PC-122 RP19-SC-122	24 to 28 AWG
Auto	Automatic crimping press	CM-105C	901-0001-0	—————	—————
	Applicator	AP105-RP13-2	901-2024-0	RP13-PC-221, 222 RP13A-SC-221, 222	24 to 28 AWG
		AP105-RP19-2	901-2014-6	RP19-PC-222 RP19-SC-222	24 to 28 AWG
Cable crimping tool		RP13A-TC-01	150-0070-0	—————	φ4.6~φ5.8 φ7~φ7.5
		RP13A-TC-02	150-0071-3	—————	φ6.3, φ7.8
Extraction tool		RP13-PC-TP	150-0021-5	Male contact	—————
		RP13A-SC-TP	150-0022-8	Female contact	—————
		RP6-SC-TP	150-0039-0	Male/female contact for RP19	—————

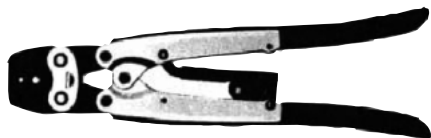

RP13A-TC-02
Cable crimping tool
(handle shape is shown as an example.)



RP13-TC-11
Manual crimping tool



Extraction tools



Automatic crimping press (Type CM-105C)

May.1.2026 Copyright 2026 HIROSE ELECTRIC CO., LTD. All Rights Reserved.

◆ Termination/assembly procedure

● Plug

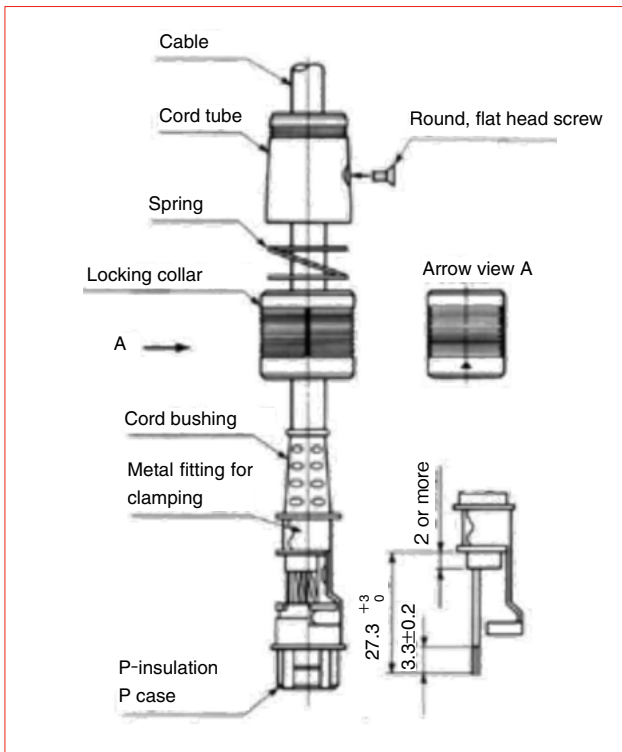

○ Assembly procedure

1. First, pass the terminated cable through the cord tube in the following order: spring, connection sleeve, and cord bushing, and then crimp and terminate the contacts.
2. Assemble the crimped and terminated contacts to the contact holes of the P-insulation P case. At this time, please make sure that the crimped contacts are securely engaged onto the contact holes of the P-insulation P case by lightly pulling the cable.
3. Attach the metal fitting by clamping to it the cord bushing and assemble these into the P-insulation P case. Then crimp the metal fitting by clamping it with the applicable tool.
4. Next, attach in the following order to the P-insulation P case: connection sleeve, spring, and cord. Then align the screw hole of the cord tube and that of the metal fitting for clamping, and tighten the round flat screw to the specified torque of 0.15 to 0.2N·m.
In addition, in order to prevent loosening of the screw, please apply Locktight 243 manufactured by Henkel Japan Ltd., Tokyo or equivalent.
5. After the assembly procedure described above has been completed, test the parts to make sure that the locking collar moves correctly.

◆ Contact Arrangement

(Standard type)

Contact arrangement		
No. of contacts	13	20

(Anti-static type)

Contact arrangement	
No. of contacts	13

(Remarks) 1. The figures shown above are viewed from the receptacle and jack mating end (plug connection end).

◆ Precautions

This product series uses silver plated contacts. Silver reacts easily to exposure to sulfur gas so the below conditions may cause tarnishing.

- Dusty environments
- Area with a high concentration area of gases such as sulfur dioxide gas, hydrogen sulfide gas, nitrogen dioxide gas and so on.
Example; In close proximity to factory exhaust, automotive emissions, etc.
- Close to heaters, or in other areas marked by extreme temperature differences or high humidity.
- Close to rubber products includes rubber adhesives.

The Electrical connection is not affected by tarnishing on a silver surface due to the wiping effect of the contact pins.

Storage

Packing state; Packed in original packing or equivalent container

Temperature -10 to +60°C

Humidity 85% Max

(It is recommended that the product be stored in an area of normal level of temperature and humidity, and free of any temperature fluctuation)

Please use this products within 6 months of delivery.

(After 6 month, please check the solderability before use)

“Storage” means long-term storage of the unused products in sealed packaging, prior to assembly to PCB.

Please note that the white label on the connector may come off due to solvents such as alcohol.

