



NPS3102A; NPS3102B

12 V, 2 A to 13.5 A, 17 mΩ eFuse

Rev. 2 — 16 January 2026

Product data sheet

1. General description

NPS3102A and NPS3102B are low-ohmic (17 mΩ), high current (13.5 A), resettable electronic fuses that are targeted for 12 V applications. They are designed to protect downstream loads from exposure to excessive voltage and protect the power supply from load faults and large inrush currents.

Output slew rate is controlled by a capacitor at dVdt pin. Current limit can be adjusted in the 2 A to 13.5 A range using a resistor at ILIM pin. The voltage at ILIM pin can also be used as a measure of the load current in real-time. The devices include a built-in over voltage clamp that will limit the output voltage during input over voltage conditions.

The devices also include a multi-function EN/FLT pin. When the pin is left floating and the voltage at IN is greater than the under voltage lock-out, the devices turn on. During operation, the voltage at the pin can be used as a fault indicator to determine if the devices are operating normally. Pulling the EN/FLT pin low will turn off the devices.

During thermal shutdown, both devices disable the integrated pass-FET if the die temperature crosses the over temperature threshold. The NPS3102A latches off under a thermal shutdown event and requires user reset by toggling the EN/FLT pin or cycling the voltage at the IN pin. The NPS3102B integrates auto-retry, which safely attempts to re-enable the pass-FET without the need for user intervention.

2. Features and benefits

- Up to 18 V operating range, 21 V absolute maximum
- Integrated 17 mΩ pass MOSFET
- 15 V output voltage clamp
- 2 A to 13.5 A adjustable output current clamp
- 2 μs short circuit protection response time
- Programmable output rise time control
- Built-In thermal shutdown with fault alert pin
- Fault response options: latch-off, auto-retry
- Leadless plastic package; 10 terminals, body 3.0 x 3.0 x 0.75 mm (DFN3030-10/SOT8037-1)
- ESD protection:
 - HBM ANSI/ESDA/JEDEC JS-001 class 2 exceeds 2000 V
 - CDM ANSI/ESDA/JEDEC JS-002 class C3 exceeds 1000 V
- Specified from $T_j = -40\text{ °C}$ to $+125\text{ °C}$

3. Applications

- Server
- Solid State Drive (SSD) and Hard Disk Drive (HDD)
- Mobile infrastructure
- Fan control
- Hot-Swap/Plug

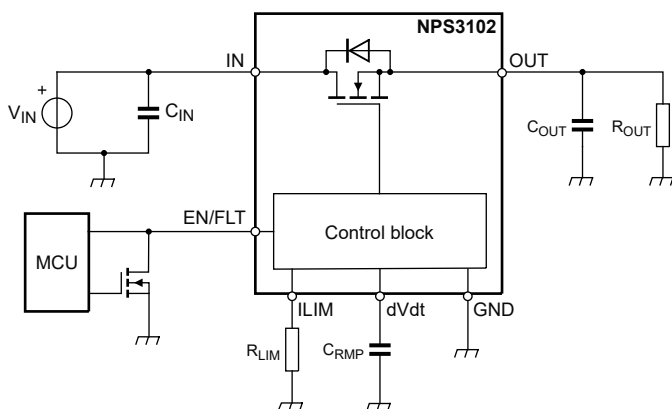

aaa-040448

Fig. 1. Typical Application

4. Ordering information

Table 1. Ordering information

Type number	Package			Version
	Temperature range	Name	Description	
NPS3102AGB NPS3102BGB	-40 °C to +125 °C	DFN3030-10	leadless plastic package; 10 terminals; body 3.0 × 3.0 × 0.75 mm	SOT8037-1

5. Marking

Table 2. Marking codes

Type number	Marking code
NPS3102AGB	s2A
NPS3102BGB	s2B

6. Block diagram

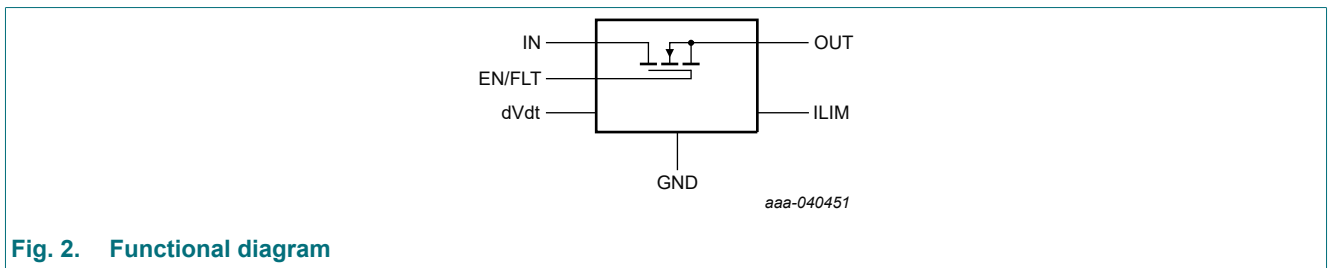

Fig. 2. Functional diagram

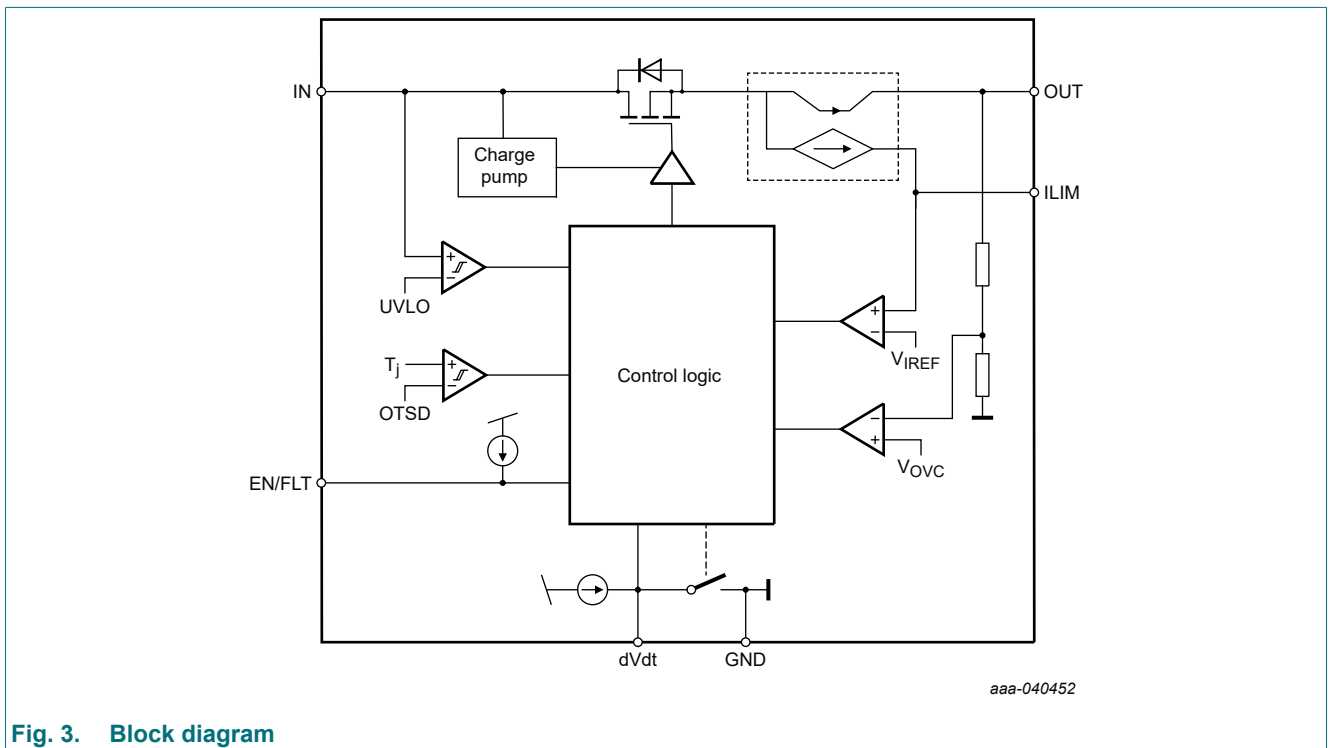
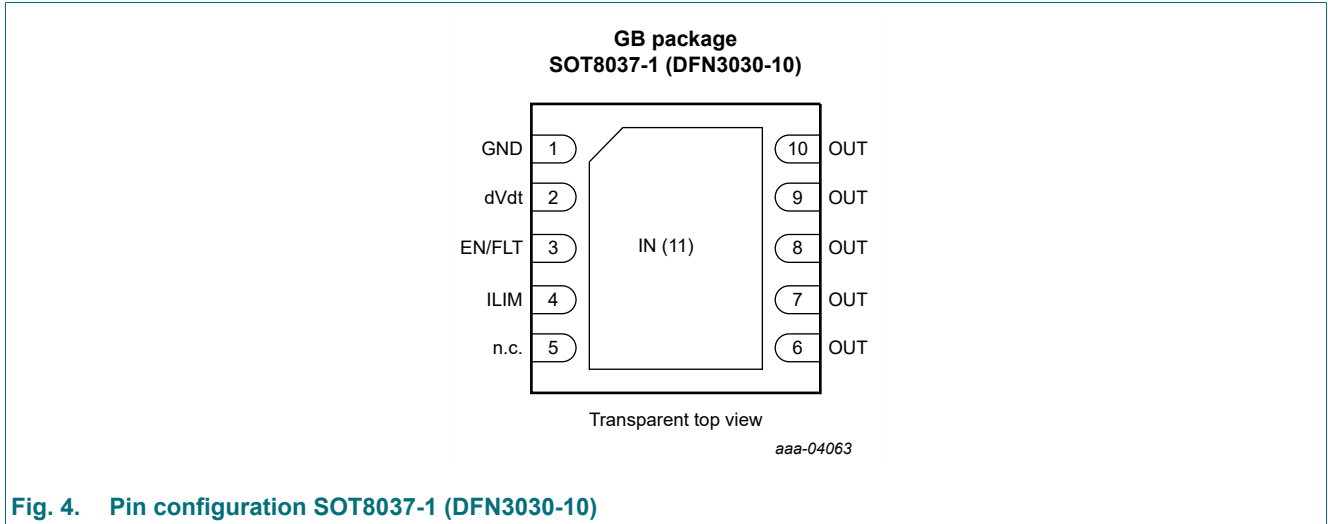

Fig. 3. Block diagram

7. Pinning information

7.1. Pinning



7.2. Pin description

Table 3. Pin description

Symbol	Pin	Description
GND	1	Ground (0 V)
dVdt	2	Controls the output voltage rise time once the device has been enabled. Rise times are proportional to the value of the capacitor at this pin. A minimum of 4.7 nF is recommended at this pin. Do not actively drive this pin.
EN/FLT	3	A 3-state, bidirectional interface that serves to enable/disable the output, and alert monitoring circuits when the eFuse enters or exits thermal shutdown. Do not actively drive this pin to any voltage except for GND. Use an open-drain or open-collector pull-down component to set the EN/FLT logic. See Section 13 for more details.
ILIM	4	Current limit configuration. Connect a resistor between this pin and GND to set the current limit. The voltage at this pin can be monitored for real-time load current information.
n.c.	5	Not connected. Do not connect this pin to a trace on the PCB.
OUT	6, 7, 8, 9, 10	Output voltage of the device, connected to the downstream loads.
IN	11	Positive input supply voltage to the device.

8. Limiting values

Table 4. Limiting values

In accordance with the Absolute Maximum Rating System (IEC 60134).

Symbol	Parameter	Conditions	Min	Typ	Max	Unit
V _{IN}	input voltage pin IN		-0.3	-	21	V
V _{OUT}	output voltage pin OUT		-0.3	-	V _{IN} + 0.3	V
V _{EN/FLT}	EN/FLT pin voltage		-0.3	-	3	V
V _{dVdt}	dVdt pin voltage		-0.3	-	3	V
V _{ILIM}	ILIM pin voltage		-0.3	-	V _{IN}	V
I _{OUT}	continuous load current		internally limited			A
T _j	junction temperature		-40		Internally Limited	°C
T _{stg}	storage temperature		-65		150	°C

9. ESD ratings

Table 5. ESD ratings

Symbol	Parameter	Conditions	Min	Typ	Max	Unit
V _{ESD}	electrostatic discharge voltage	HBM ANSI/ESDA/JEDEC JS-001 class 2	-2000	-	2000	V
		CDM ANSI/ESDA/JEDEC JS-002 class C3	-1000	-	1000	V

10. Recommended operating conditions

Table 6. Operating conditions

Symbol	Parameter	Conditions	Min	Typ	Max	Unit
V _{IN}	input voltage pin IN		9	-	18	V
R _{LIM}	external resistor at pin ILIM		226	-	1870	Ω
V _{dVdt}	voltage rating of external capacitor at dVdt pin		6.3	-	-	V
C _{dVdt}	capacitance at dVdt pin		4.7	-	-	nF
T _j	junction temperature		-40	-	125	°C

11. Thermal characteristics

Table 7. Thermal characteristics

Symbol	Parameter	Conditions	Min	Typ	Max	Unit
R _{θja}	junction to ambient thermal resistance	As per JEDEC JESD51-7	-	62	-	°C/W
		4 layers, 1oz copper, 4 thermal vias	-	38	-	°C/W
Ψ _{JT}	junction to top characterization parameter		-	3.7	-	°C/W

12. Electrical characteristics

Table 8. Electrical characteristics

At recommended operating conditions; voltages are referenced to GND (ground = 0 V)

$V_{IN} = 12\text{ V}$, $EN/FLT = \text{open}$, $C_{dV/dt} = \text{open}$, $R_{LIM} = 604\ \Omega$, $R_L = \text{open}$, $C_{IN} = 0.1\ \mu\text{F}$,

$C_L = 0.1\ \mu\text{F}$, unless otherwise stated.

Symbol	Parameter	Conditions	$T_j = -40\text{ °C to }125\text{ °C}$			Unit
			Min	Typ[1]	Max	
Power consumption						
I_{IN}	quiescent current		-	320	500	μA
I_{OFF}	OFF-state (disabled) current	$EN/FLT = \text{GND}$	-	100	200	μA
I_{TSD} [2]	thermal shutdown current	$T_j = T_{SD}$; EN/FLT is driven to V_{FAULT} by eFuse	-	-	1000	μA
Undervoltage lockout						
V_{UVLO_R}	undervoltage lockout rising threshold	EN/FLT changes from V_{EN_UVLO} to V_{IPU}	7.8	8.4	8.9	V
V_{UVLO_F}	undervoltage lockout falling threshold	EN/FLT changes from V_{IPU} to V_{EN_UVLO}	7.0	7.6	8.1	V
V_{UVLO_HYS}	undervoltage lockout hysteresis		-	0.8	-	V
Overvoltage and overcurrent protection						
V_{OVC}	output voltage clamp	$V_{CC} = 18\text{ V}$; $R_L = 100\ \Omega$;	13.5	15	16	V
I_{LIM} [2]	output hold/limit current	$R_{LIM} = 226\ \Omega$; $V_{IN} - V_{OUT} = 0.5\text{ V}$	12.4	13.8	15.1	A
		$R_{LIM} = 604\ \Omega$; $V_{IN} - V_{OUT} = 0.5\text{ V}$	5	5.55	6.1	A
$I_{LIM_R_OPEN}$ [2]	output hold/limit current - open I_{LIM}	$R_{LIM} = \text{Open}$	-	0	-	A
$I_{LIM_R_SHORT}$ [2]	output hold/limit current - short I_{LIM}	$R_{LIM} = 0\ \Omega$	-	20	-	A
G_{IMON}	current monitor gain	I_{LIM} / I_{OUT}	184	203	216	$\mu\text{A/A}$
Power MOSFET						
R_{ON}	ON-state resistance		-	17	30	mΩ
I_{LKG}	leakage current (from IN to OUT)	$EN/FLT = \text{GND}$; $R_L = 10\ \text{k}\Omega$; $T_j = 25\text{ °C}$	-	0.1	6	μA
		$EN/FLT = \text{GND}$; $R_L = 10\ \text{k}\Omega$; $T_j = -40\text{ °C to }+85\text{ °C}$	-	-	30	
		$EN/FLT = \text{GND}$; $R_L = 10\ \text{k}\Omega$; $T_j = -40\text{ °C to }+125\text{ °C}$	-	-	100	
Bi-directional enable and fault functionality						
V_{IL}	input voltage to reset eFuse	EN/FLT pin pulled low externally	-	-	0.4	V
V_{IPU}	EN/FLT voltage in normal operation	EN/FLT pin voltage set by NPS3102	2.2	2.35	2.5	V
V_{FAULT}	EN/FLT voltage due to thermal shutdown	EN/FLT pin voltage set by NPS3102	0.7	0.9	1.3	V
V_{EN_UVLO}	EN/FLT voltage when $V_{IN} < V_{UVLO_F}$	EN/FLT pin voltage set by NPS3102	-	-	0.3	V
I_{IL}	current sourced out of EN/FLT pin when in thermal shutdown		-	17	25	μA
N [2]	fault signal fanout	number of devices that can be paralleled	-	-	3	-

Symbol	Parameter	Conditions	T _j = -40 °C to 125 °C			Unit
			Min	Typ[1]	Max	
Thermal shutdown						
T _{SD}	[2] thermal shutdown temperature	rising T _j	150	185	200	°C
T _{HYST}	[2] temperature hysteresis	falling T _j	-	30	-	°C

[1] Typical values are measured at T_j = 25 °C.
 [2] Not production tested. Guaranteed by Design and/or Characterization.

Table 9. Dynamic characteristics

V_{CC} = 12 V, EN/FLT = open, C_{dV/dt} = open, R_{LIM} = 604 Ω, R_L = open, C_{IN} = 0.1 μF, C_L = 0.1 μF, unless otherwise stated.

Symbol	Parameter	Conditions	T _j = 25 °C			Unit
			Min	Typ	Max	
t _{ONDLY}	EN on delay time	V _{ENFLT} = V _{IPU} to V _{OUT} = 10% of V _{IN} ; C _{OUT} = 10 μF	-	170	-	μs
t _{OFFDLY}	EN off delay time	V _{ENFLT} < V _{IL} to V _{OUT} =90% of V _{IN} ; C _{OUT} = 10 μF	-	18	-	μs
SR	output slew rate	C _{dV/dt} =10 nF; C _{OUT} = 10 μF	-	3.3	-	V/ms
		C _{dV/dt} =33 nF; C _{OUT} = 10 μF	-	1	-	V/ms
t _{OVC}	output voltage clamp response time	V _{IN} rises above V _{OVC} to peak V _{OUT} ; R _L = 100 Ω	-	5	-	μs
t _{ILIM}	output current clamp response time	I _{OUT} > I _{LIM} + 20% to I _{OUT} within 5% of I _{LIM} ; R _L = 1.5 Ω	-	20	-	μs
t _{SC}	output short circuit response time	I _{OUT} > I _{LIM} + 20% to I _{OUT} peak; R _L = 0.1 Ω	-	2.5	-	μs
t _{TSD_ARI}	thermal shutdown auto-retry interval	NPS3102B T _j = T _{SD} - T _{HYST}	-	1	2	ms

12.1. Typical characteristics graphs

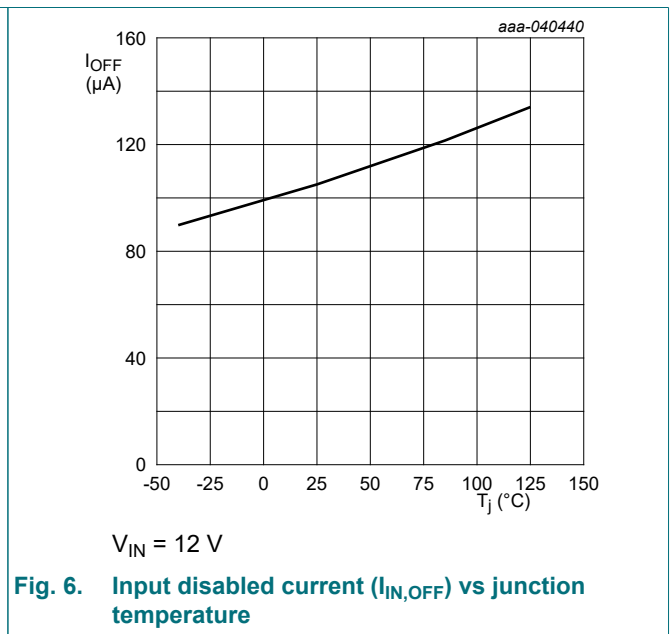
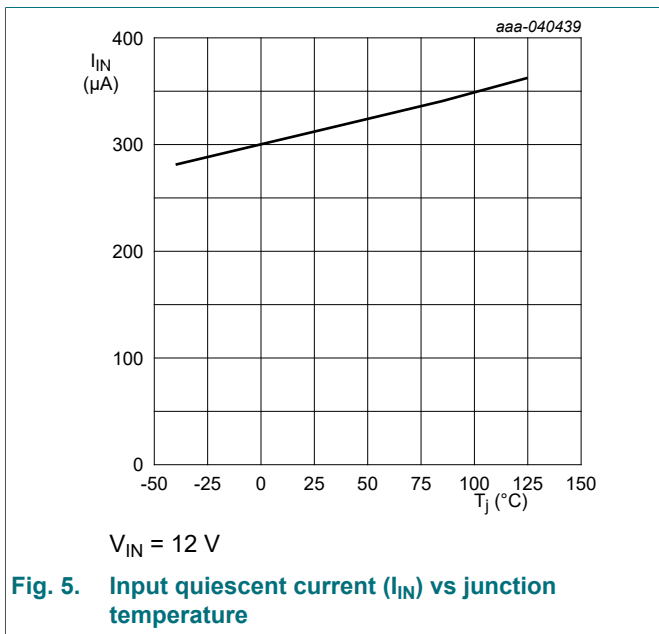

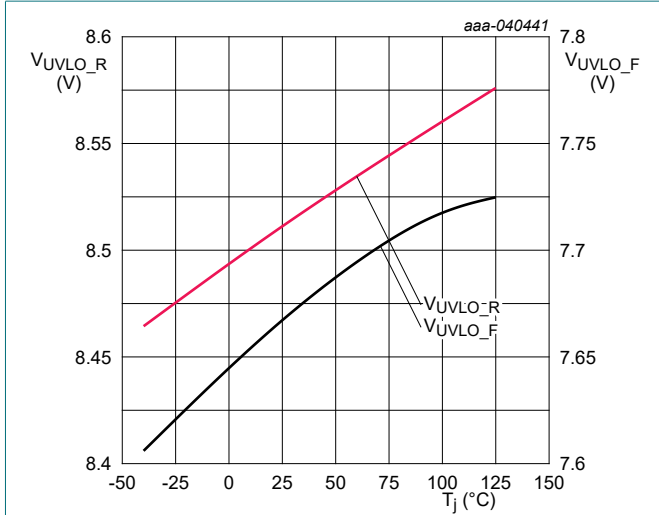

Fig. 7. UVLO rise and fall thresholds (V_{UVLO_R}) and V_{UVLO_F}) vs junction temperature

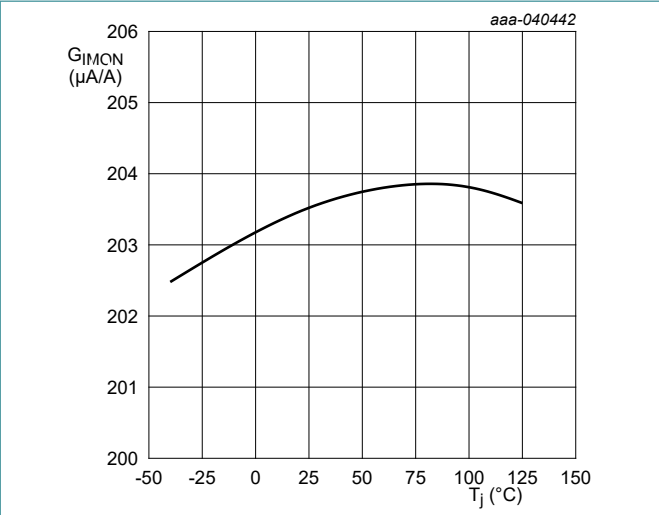

Fig. 8. Current gain (G_{IMON}) vs junction temperature
 $V_{IN} = 12 V$

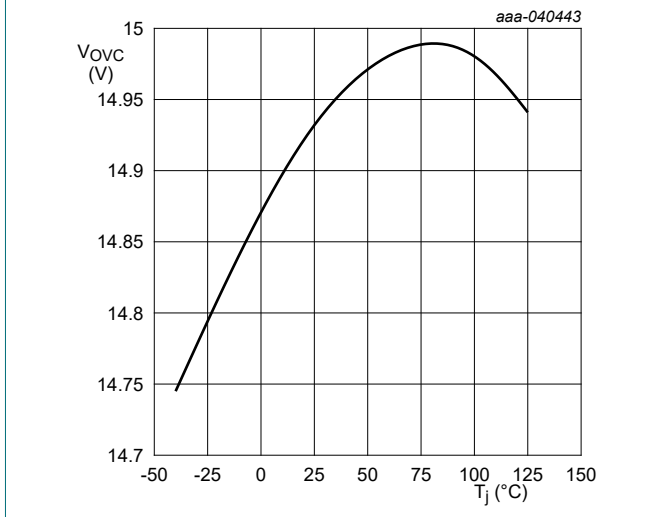

Fig. 9. Output clamp voltage (V_{OVC}) vs junction temperature
 $V_{IN} = 18 V$

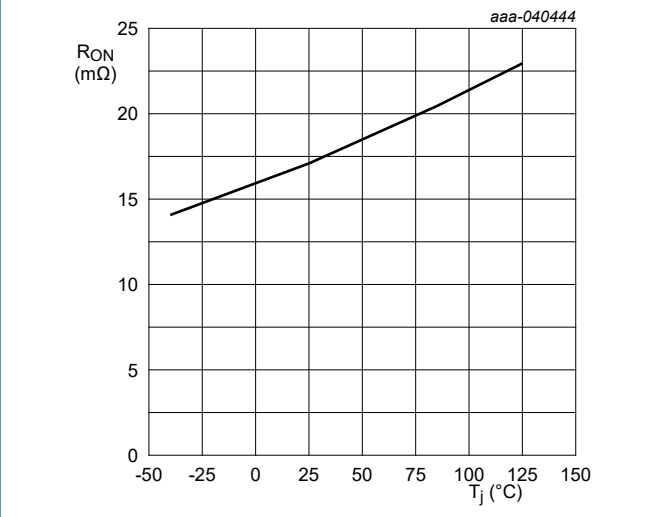

Fig. 10. On-state resistance (R_{ON}) vs junction temperature
 $V_{IN} = 12 V$

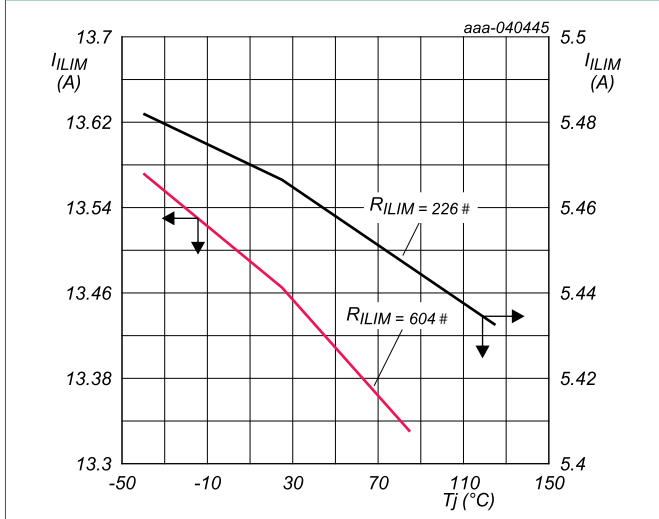

Fig. 11. Current limit (I_{LIM}) vs junction temperature
 $V_{IN} = 12 V$

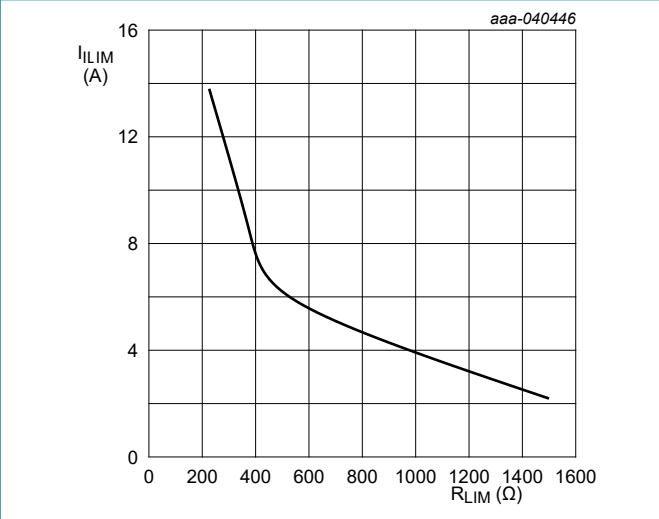
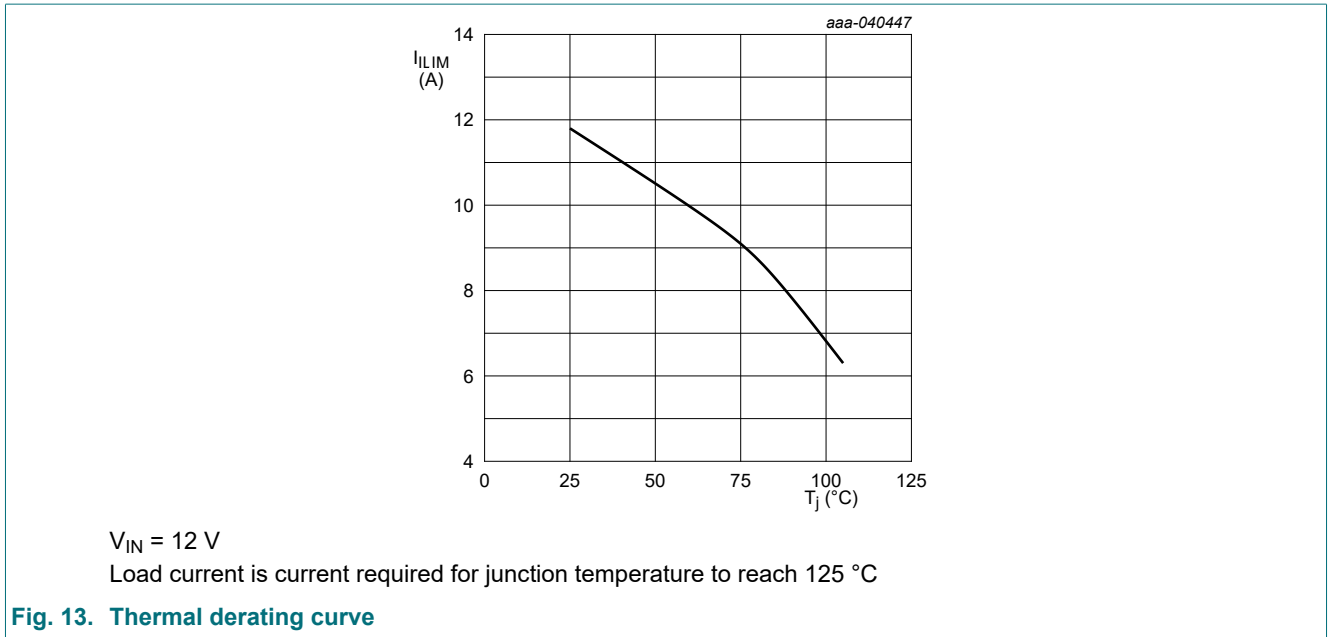

Fig. 12. Current limit (I_{LIM}) vs resistance (R_{LIM})
 $V_{IN} = 12 V; T_j = 25 \text{ }^\circ\text{C}$



12.2. Typical waveforms

$V_{IN} = 12\text{ V}$, $EN/FLT = \text{open}$, $C_{dV/dt} = 10\text{ nF}$, $R_{LIM} = 1.5\text{ k}\Omega$, $R_L = \text{open}$, $C_{IN} = 10\text{ }\mu\text{F}$,
 $C_L = 10\text{ }\mu\text{F}$, $T_j = 25\text{ }^\circ\text{C}$ unless otherwise stated.

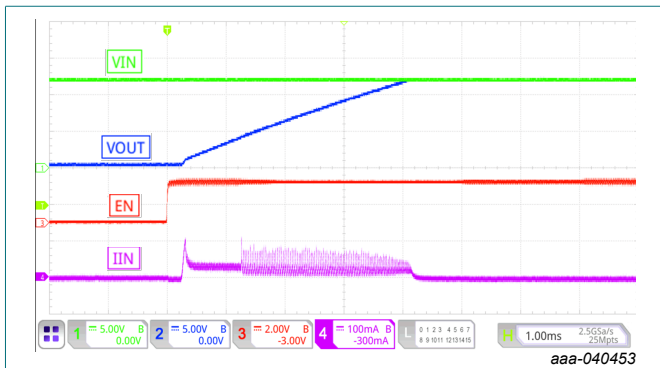
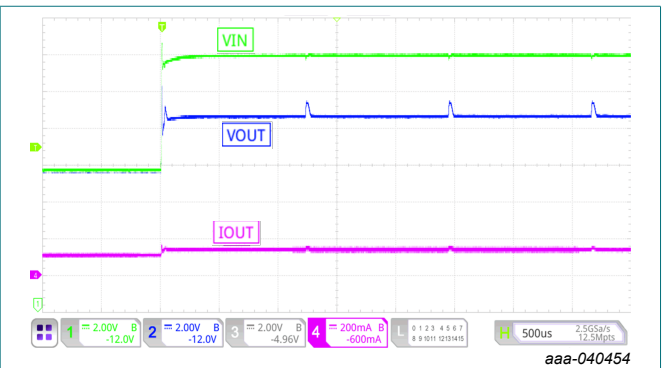
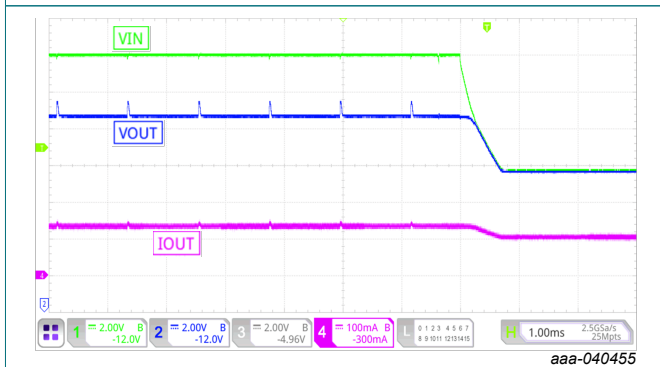

Fig. 14. Soft start with 10 nF at dVdt pin



V_{IN} step up from 12 V to 18 V, $R_L=100\text{ }\Omega$

Fig. 15. Over voltage clamp operation



V_{IN} drops from 18 V to 12 V, $R_L=100\text{ }\Omega$

Fig. 16. Recovery from an over voltage clamp

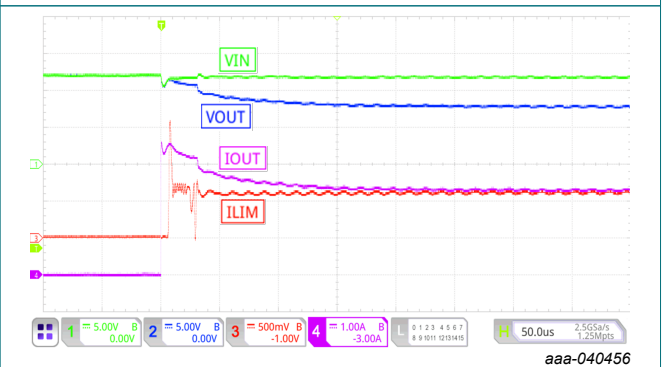

R_L step from open to 3.3 Ω

Fig. 17. Current limit operation in an overload condition

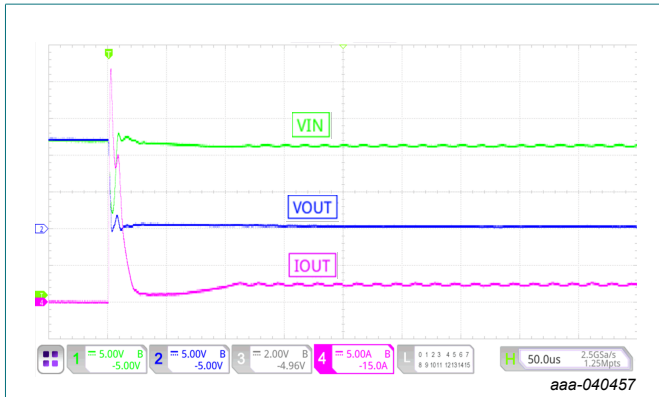

OUT shorted with 0.1 Ω resistor

Fig. 18. Short circuit response

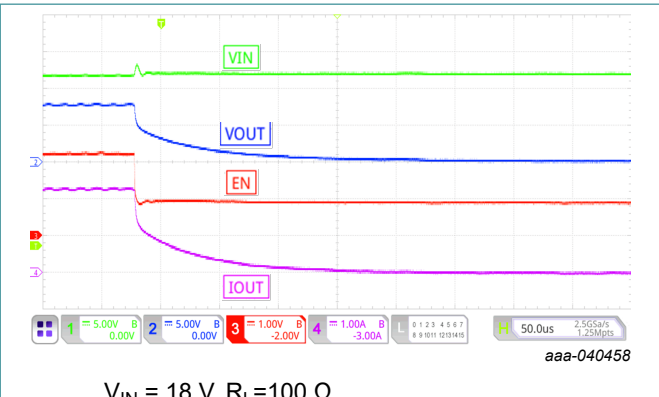

$V_{IN} = 18\text{ V}$, $R_L = 100\ \Omega$

Fig. 19. Over temperature shutdown due to persistent input over voltage

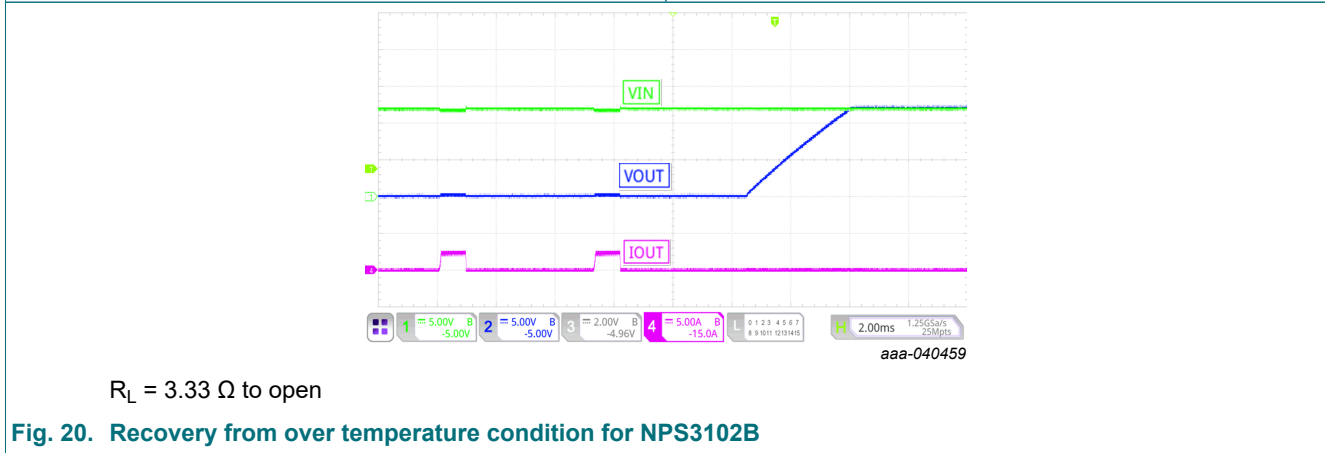

$R_L = 3.33\ \Omega$ to open

Fig. 20. Recovery from over temperature condition for NPS3102B

13. Feature description

Basic operation

NPS3102 is an electronic fuse device, integrating a low ohmic pass FET along with several system protection features to ensure safe power delivery to a downstream load.

NPS3102 starts its operation by monitoring the voltage on its IN pin and its EN/FLT pin. Once the pin voltages cross their respective thresholds (V_{UVLO_R} and V_{IPU}), NPS3102 will enable the pass FET, delivering power to the load that is connected to the OUT pins. The power ramp is regulated by the configuration of the dVdt pin.

In normal operation, NPS3102 monitors the load current and input voltage, using both characteristics to regulate the pass FET configuration. If the load current crosses the programmed over-current limit threshold (I_{LIM}) or if the load voltage crosses the over-voltage limit threshold (V_{OVC}), the device will reduce the conductivity of the pass FET to restrict load current and voltage to the respective threshold values. NPS3102 has a built-in mechanism to provide a rapid protection response to rapid over-current events (i.e., short-circuit).

NPS3102 also integrates a junction temperature monitoring block that will disconnect power delivery before the junction temperature rises to a point where it would be permanently damage the device.

Start-up

NPS3102 starts up when the input voltage V_{IN} exceeds the rising under-voltage lockout threshold (V_{UVLO_R}) and the voltage at the EN/FLT pin reaches V_{IPU} . Both V_{IN} and $V_{EN/FLT}$ are continuously monitored. If the input voltage falls below V_{UVLO_F} or if the EN/FLT pin voltage drops below V_{IL} , the device turns off.

Soft start

Once the device starts up, the device starts charging the output capacitor at a slew rate determined by the capacitor connected at the dVdt pin. There are a few modes of operation during the soft start period.

- While the EN/FLT pin is held low, the internal charge pump is turned off.
- When the EN/FLT pin exceeds V_{IPU} , the internal charge pump is turned on in a low power mode. This mode lasts for approximately 1 ms. This mode is intended to act as a fail-safe to limit the output slew rate in case there is insufficient capacitance at the dVdt pin.
- After the 1 ms time, the charge pump is switched to a high power mode.

Once the charge pump shifts to the high power mode, the device uses an internal resistor divider to step down the output voltage and compares this voltage to the voltage at the dVdt pin.

- If the slew rate of the output voltage is less than the slew rate of the dVdt pin voltage, the charge pump is turned on in the strong mode.
- If the slew rate of the output voltage is more than the slew rate of the dVdt pin voltage, the charge pump is turned off.

Thus, by turning the charge pump off and on, the device regulates the output slew rate to match the slew rate of the dVdt pin.

The capacitor that is required at the dVdt pin can be computed based on the rise time desired for the output voltage.

$$C_{dVdt} = (3.4 \times 10^{-6}) \times t_R$$

where C_{dVdt} is the capacitor at the dVdt pin and t_R is the desired 10% - 90% rise time of the output voltage.

[Fig. 14](#) shows the start-up waveform with a 10 μF load capacitor and a 10 nF capacitor at the dVdt pin.

Note that the maximum capacitor at dVdt pin is determined by the load capacitance.

$$C_{dVdt,max} = \frac{C_{OUT}}{60}$$

where C_{OUT} is the total output capacitance including those of any downstream loads. For example, a 10 μF load capacitance leads to a maximum capacitance of 167 nF at the dVdt pin.

Normal operation

Once the device completes inrush, the pass FET is completely turned on to achieve a low on-state resistance. The device constantly monitors the output voltage and the current through the device.

Output over-voltage clamp

The over-voltage protection in the NPS3102 is designed to be fast acting and consume low power in normal operation. When the NPS3102 is enabled, the over-voltage comparator continuously monitors the OUT pin voltage. Once the OUT pin voltage rises above the threshold value V_{OVC} , the internal over-voltage comparator quickly turns off the pass-FET and clamps its gate voltage.

As the output voltage droops due to the load, the IC detects that the output is lower than the clamp voltage. At this point, the device releases the over-voltage circuitry and turns on the pass-FET. This causes the output to rise and detect over voltage (if the input is still above the over voltage limit) and restarts the clamp circuit.

Activation of the over-voltage clamp elevates the power dissipation of the pass FET due to the increased voltage difference between the IN and OUT pins. This increased power dissipation will also elevate the NPS3102 junction temperature, depending on the load current. A prolonged over-voltage condition can increase the junction temperature high enough to trigger a thermal shutdown (see [Thermal shutdown protection](#)).

[Fig. 15](#) shows the device entering over voltage protection with a 100 mA load. When the input voltage jumps from 12 V to 18V, the output voltage clamps to 15 V. The short spikes seen in the output voltage are due to the periodic release of the over voltage circuitry as described. [Fig. 16](#) shows the recovery of the part when the input over voltage condition disappears. In both cases, there is no disruption to the load.

Current monitoring and over current protection

During normal operation, the device constantly monitors the output current (I_{OUT}). The current is mirrored and sourced out of the ILIM pin. The ratio of the current sourced out of the ILIM pin and the current through the pass FET is G_{IMON} . A resistor to ground at ILIM pin (R_{LIM}) converts this current into a voltage (V_{ILIM}), which can be used a real time measurement of the load current.

$$I_{OUT} = \frac{V_{ILIM}}{G_{IMON} \times R_{LIM}}$$

R_{LIM} is chosen to program the over current limit (I_{LIM}).

$$R_{LIM} = \frac{0.63 \text{ V}}{G_{IMON} \times I_{LIM}}$$

When the load current exceeds the programmed I_{LIM} value, the device limits the current to I_{LIM} . This is done in a hysteretic manner by turning the pass FET on and off. The FET turn off is done quickly to ensure no large over current conditions occur, whereas the FET turn-on is controlled so that the hysteresis frequency does not become too large. The device remains in this mode until the overload condition resolves or the device hits its over temperature shut down limit (see [Thermal shutdown protection](#)).

[Fig. 17](#) shows the behavior of the device to an over current event. In this case, R_{LIM} is set to 1.5 kΩ, which is about a 2 A current limit. When a 3 A over current event occurs, the device limits the output current to the programmed value. This also causes the output voltage drop and increases the power dissipation in the device (in this case, to approximately 8 W).

The NPS3102 is protected against ILIM pin open or short to ground conditions. If the ILIM pin is left open, the device will not allow any current to pass. If ILIM pin is shorted to ground, then the over current limit is set to 22 A internally. In either case, the device will not get damaged.

Short circuit protection

When the output of the NPS3102 is shorted to ground, the current through the device increases rapidly. Short circuit protection comparator is activated when the voltage at ILIM pin exceeds 1.2 V. At this point, the device pulls down the gate of the NFET rapidly to prevent high peak currents and limit the output current to the programmed value.

[Fig. 18](#) shows the behavior of the device to a short circuit condition which is initiated by shorting the output with a 0.1 Ω load. The device reduces the gate voltage to the FET within 2 μs, which causes the load current to drop. Once the load current drops to a safe value, the output current limit circuit is engaged.

Bi-directional enable/fault functionality

The EN/FLT pin is a bi-directional I/O. The pin has a weak pull-up internal to the device. This pin can be used to control the device, monitor the status of the device, and connect multiple devices in parallel.

To use this pin as a control input, connect it to an open-drain FET or a GPIO pin of a micro-controller configured as an open-drain output. Pulling the pin down to GND (less than V_{IL}) turns off the NPS3102. Turning off the pull-down FET turns on the NPS3102.

The pin can be used as a status pin by monitoring the voltage at the pin.

Low level (V_{IL}) – A voltage below this level indicates NPS3102 has been turned off.

Mid level (V_{FAULT}) – A voltage within this range indicates NPS3102 is in Thermal Shutdown.

High level (V_{IPU}) – A voltage above this level indicates NPS3102 has been turned ON.

Multiple eFuses can be paralleled to increase the load current.

The EN/FLT pin is designed so that if two or three NPS3102 are paralleled, their EN/FLT pins can be tied together as shown by [Fig. 22](#). If one of the eFuses enters thermal shutdown, it will pull down the EN/FLT common node to V_{FAULT} so that an external control circuit can detect the overheating event and ground the EN/FLT common node to stop all the eFuses simultaneously. (see [Paralleling eFuses](#)).

Thermal shutdown protection

The NPS3102 has internal SOA management to prevent an elevated junction temperature (T_j) from permanently damaging the pass FET. In normal operation, the NPS3102 continuously monitors its internal junction temperature. If it crosses the over temperature threshold (T_{SD}), the pass FET is disabled and the load is disconnected. The EN/FLT pin will be driven internally to V_{FAULT} while the NPS3102 remains in thermal shutdown (see [Bi-directional enable/fault functionality](#)).

In NPS3102A, there are two options to exit thermal shutdown and attempt to resume normal operation

- power cycle the IN pin, or
- toggle the EN/FLT pin.

Note that if T_j has not fallen below ($T_{SD} - T_{HYST}$), NPS3102 will re-enter thermal shutdown.

If user-trigger to resume normal operation is not a viable option, then NPS3102B is recommended due to its auto-retry feature. This feature enables the NPS3102B to automatically resume normal operation once T_j has dropped to ($T_{SD} - T_{HYST}$). Once T_j has sufficiently dropped, the device will wait for an additional delay of t_{TSD_ARI} , and then attempt to re-enable the pass FET. The pin voltage will return to V_{IPU} .

- The junction temperature of the NPS3102 can exceed its internal limit TSD in a few scenarios.
- The rms current through the device exceeds the maximum current in the temperature de-rating curve (see [Fig. 13](#))
- The device is in over current protection mode causing excessive power dissipation
- The device is in the over voltage clamp mode with a load current causing excess power dissipation
- Start-up with a large load capacitor which causes excessive power dissipation.

Behavior of the NPS3102 to an over temperature condition is shown in [Fig. 19](#). In this case, a persistent over current condition causes the device to heat up and shut down. When the device shuts down, the EN/FLT pin is pulled to V_{FAULT} to indicate that the device is in thermal shutdown.

[Fig. 20](#) shows the recovery of the NPS3102B device from a persistent overload condition. The device keeps trying to restart until both the over temperature condition and overload conditions disappear. At this point, the device enters soft start and ramps up the load capacitor.

14. Application information

Basic operation

The NPS3102 is an electronic fuse intended to overcome the disadvantages of one shot fuses, PTC fuses or discrete protection circuits. It protects the downstream components against overvoltage and limits the maximum current flow during a fault ensuring maximal safety. With an input voltage range of 9 V to 18 V and a programmable current limit between 2 A and 13.5 A, it can be used in a broad range of applications where protection is needed.

Typical standalone application

Fig. 21 depicts a standard standalone application. This application is designed to limit the current to 13.5 A and an output voltage rise time of 3 ms.

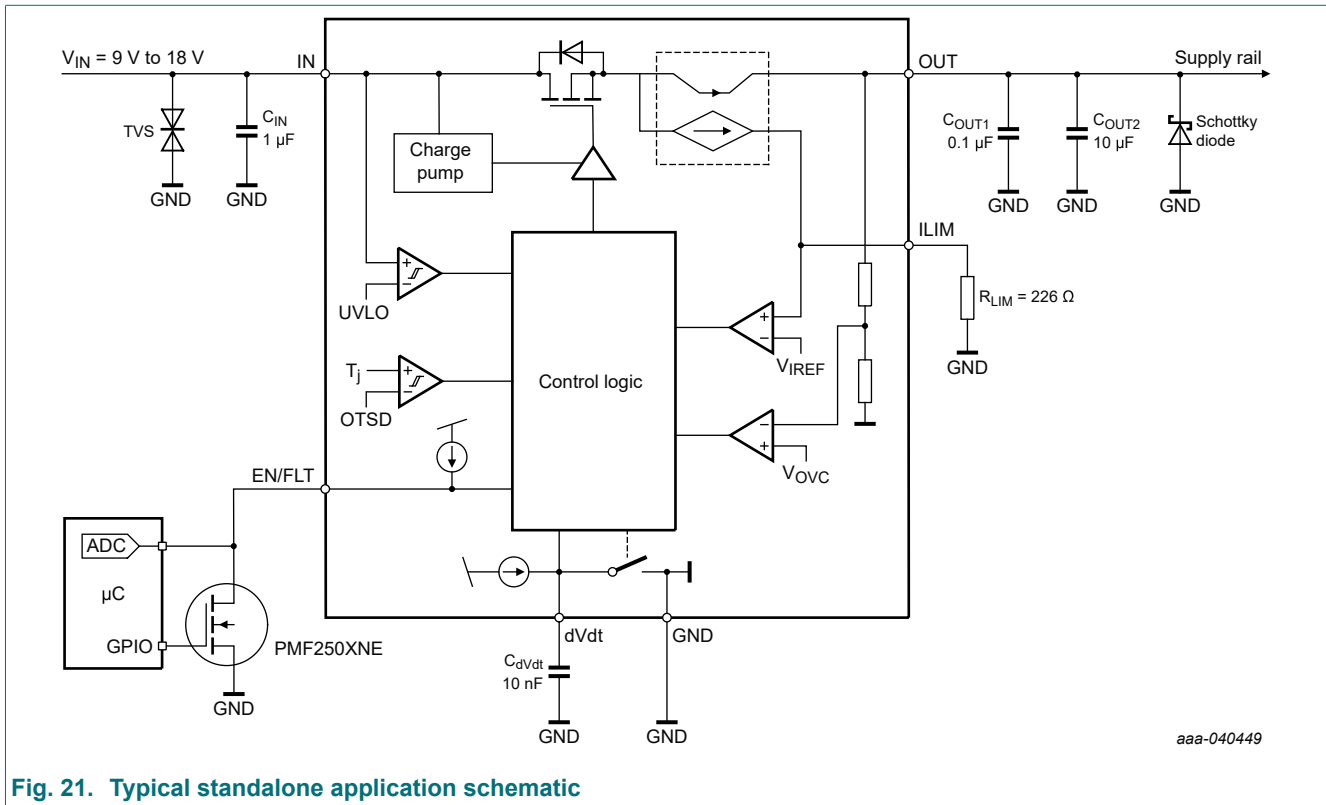

Fig. 21. Typical standalone application schematic

The current limit threshold is controlled by the value of R_{LIM} and can be calculated by:

$$R_{LIM} = \frac{0.63 \text{ V}}{G_{IMON} \times I_{LIM}} = \frac{0.63 \text{ V}}{203 \frac{\mu\text{A}}{\text{A}} \times 13.5 \text{ A}} = 229 \Omega$$

Rounded to an E96 resistor value this result in 226 Ω.

Both C_{IN} and C_{OUT} are needed for decoupling and transient suppression. The input transient voltage suppressor protects the eFuse against large voltage transients that might exceed the recommended voltage operating range during switching of load circuitry. These transients might occur due to parasitic inductance from the supply connection to the input of the eFuse. The Schottky diode on the output protects the eFuse from negative voltage transients. Both the TVS and the Schottky diode can be omitted, but for robustness, these are recommended. C_{dVdt} sets the output slew rate to 3 ms as per the equation below.

$$C_{dVdt} = (34 \times 10^{-6}) \times t_R = (34 \times 10^{-6}) \times 3 \text{ ms} = 102 \text{ nF}$$

Rounding the value to a standard value results in a 10 nF capacitor at dVdt pin. It is recommended to choose either a ≥ 6.3 V rated NP0/C0G or a ≥ 10 V rated X7R capacitor to minimize capacitance change due to DC bias. The minimum slew rate achievable is 1 ms, which occurs when the dVdt pin is left floating.

The bi-directional EN/FLT pin is used to disable the device using an open drain NMOS which in turn is controlled by a micro controller. During normal operation, the voltage of the EN/FLT pin can be monitored using an ADC to monitor for fault situations. The voltage across R_{LIM} can be used as a real time current monitor and can also be connected to an ADC. When using an analog switch both signals can be monitored sequentially.

If the input range of the ADC is lower than the maximum voltages at either EN/FLT or ILIM pins, the voltages need to be stepped down using external buffers. The pins are not capable of sourcing more than 1 μA to external circuitry.

Paralleling eFuses

If the current rating of a single eFuse is insufficient, or if there is a need to distribute power dissipation across the PCB, it is possible to parallel multiple eFuses. Each NPS3102 can be designed independently like if used alone. If two or three NPS3102 are operated in parallel, an external controller can be used to force a simultaneous turn off all the eFuses when the thermal shutdown of one of them trips. Fig. 22 illustrates the appropriate connection of these devices.

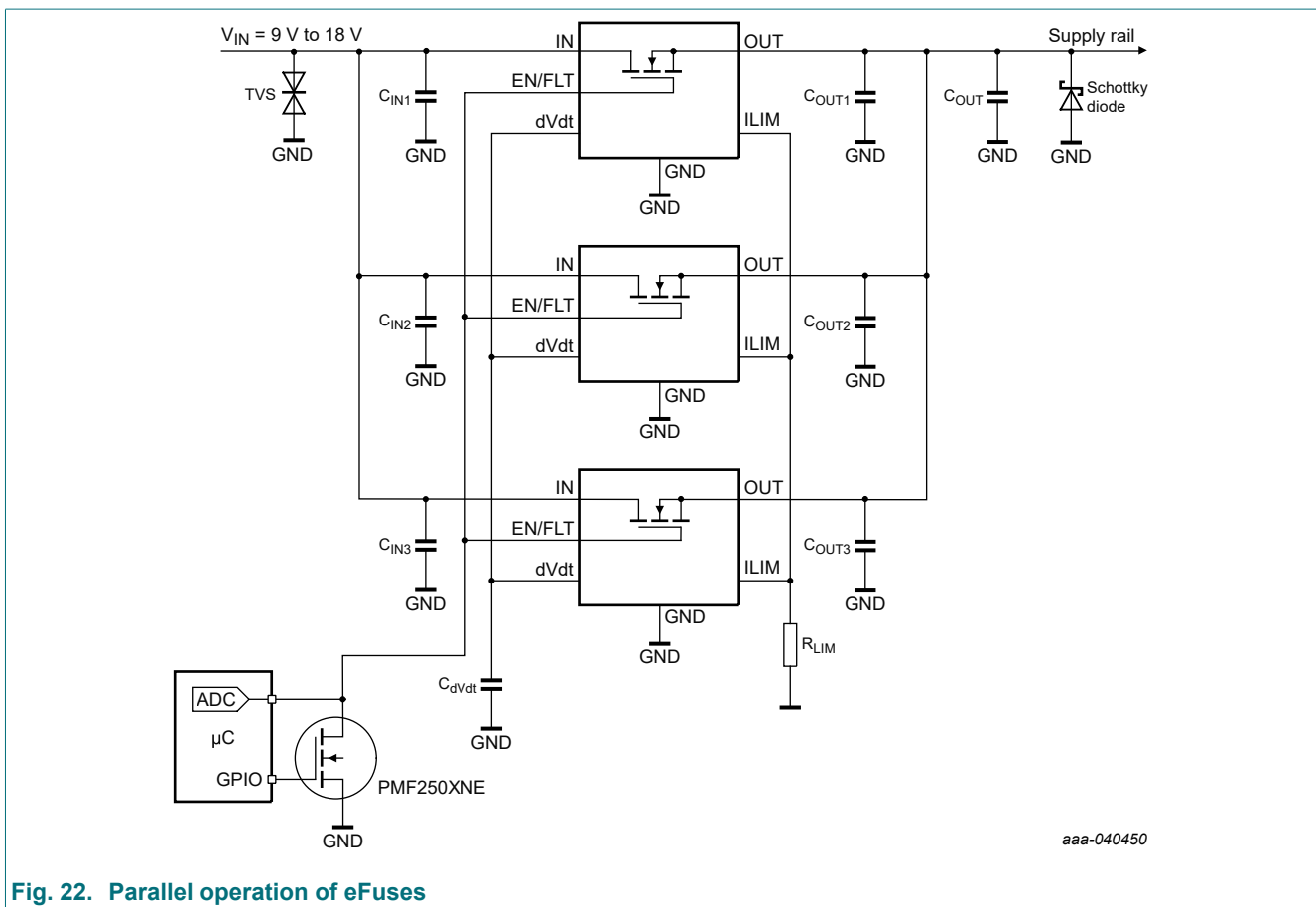

Fig. 22. Parallel operation of eFuses

Several considerations must be taken into account:

- The current charging the dVdt capacitor will be three times the value of a single device, resulting in a ramp rate that is three times faster, if the capacitor is not adjusted accordingly.
- The current through the current-limiting resistor will be three times the value of a single device. Since the voltage across this resistor triggers the current-limiting circuit, it should be one-third of the value of a single device.
- Their EN/FLT pins should be tied together to form an EN/FLT common node. This ensures that the EN/FLT common node will be set to V_{FAULT} if the thermal shutdown of one of the paralleled NPS3102 trips. In this case, the external controller can detect this situation and ground the EN/FLT pin and stop all the NPS3102 simultaneously to ensure a clean interruption of the current flow if one of the eFuses happens to get too hot.
- Each device should have its own decoupling capacitors at input and output pins.
- Careful attention must be paid to the layout. The distribution of current will significantly depend on the added series resistance, which should be equal for every eFuse. Failure to comply may result in variations in power dissipation per product, potentially leading to thermal shutdown of the system.

PCB Layout

Fig. 23 depicts a proven layout example. Both C_{IN} and C_{OUT} should be as close as possible to the device to keep the inductivity of the current loop as low as possible. Transient protection devices can be placed next to these capacitors.

To prevent unwanted activation of the thermal protection, it is advised to connect as much as possible copper area to the exposed pad of the device using thermal via's in the pad distributing the dissipated power to the V_{CC} plane.

To optimize the thermal performance of the device, it is important to design the board stack-up and copper areas on each layer correctly. A stack-up example based on the NPS3102 evaluation module is shown in Fig. 24. The minimum copper areas connected to the thermal pad of the IC for each layer is listed in Table 10. Using this PCB stack-up and a similar layout, it is possible to achieve a junction to ambient thermal impedance of 33 °C/W.

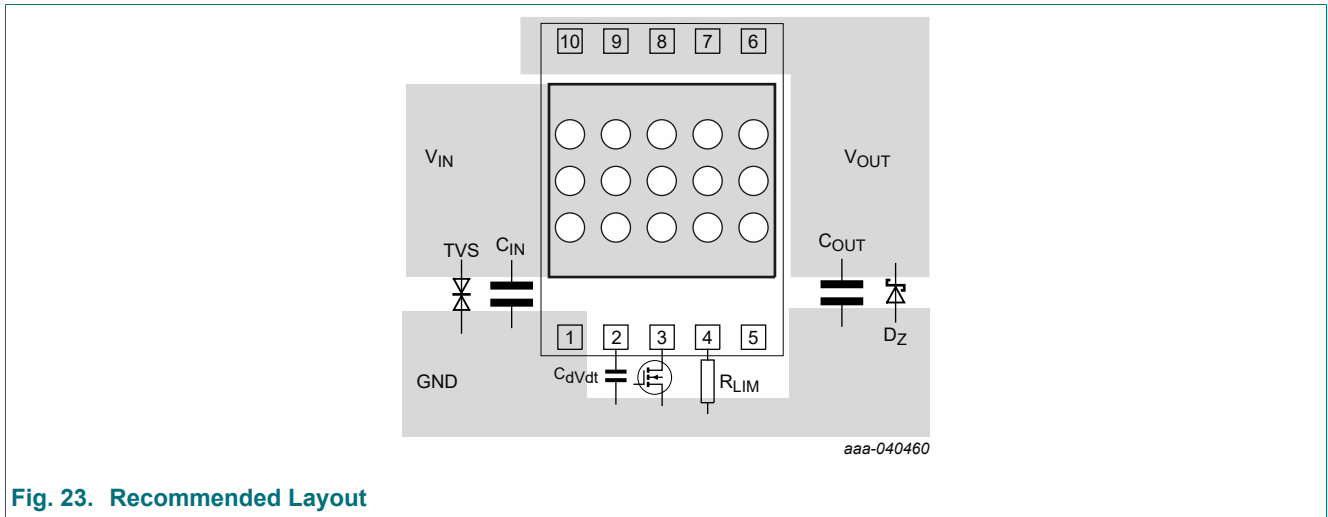

Fig. 23. Recommended Layout

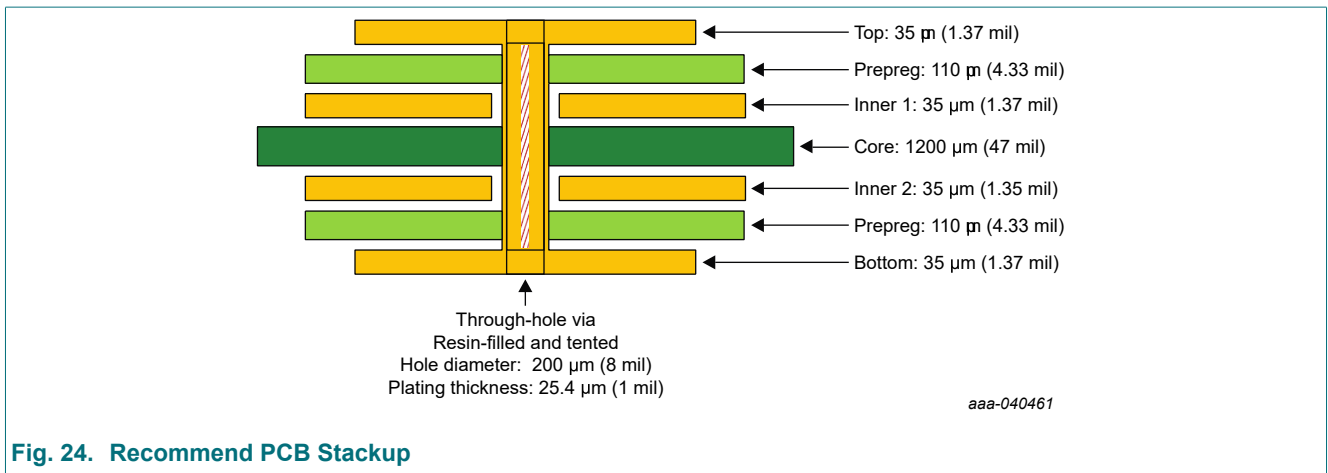

Fig. 24. Recommend PCB Stackup

Table 10. Recommended copper area in each layer

Layer	Minimum Copper area connected to thermal pad	Number of vias in thermal pad
Top	30 mm ²	15 vias arranged in a 5 x 3 pattern
Inner 1	100 mm ²	
Inner 2	20 mm ²	
Bottom	50 mm ²	

15. Package outline

DFN3030-10: Leadless plastic package; 10 terminals, body 3.0 x 3.0 x 0.75 mm

SOT8037-1

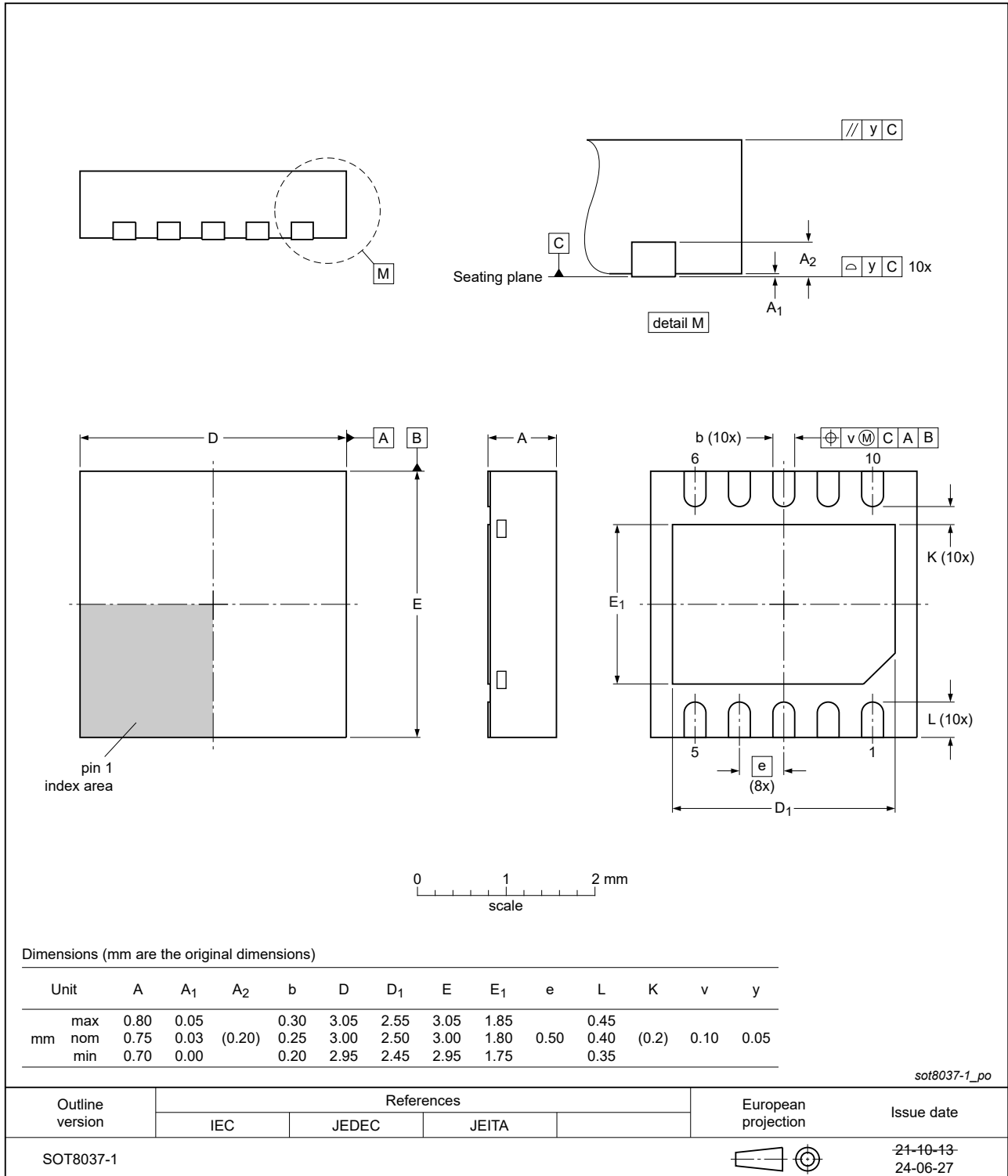

Fig. 25. Package outline SOT8037-1 (DFN3030-10)

16. Abbreviations

Table 11. Abbreviations

Acronym	Description
DUT	Device Under Test
ESD	ElectroStatic Discharge
PCB	Printed-Circuit Board
TDB	To Be Determined

17. Revision history

Table 12. Revision history

Data sheet ID	Release date	Data sheet status	Change notice	Supersedes
NPS3102 v.2	20260116	Product data sheet	-	NPS3102 v.1
Modifications:	<ul style="list-style-type: none">• Table 8 and Table 9 updated. (errata)• Section 13 and Section 14 updated.			
NPS3102 v.1	20240718	Product data sheet	-	-

18. Legal information

Data sheet status

Document status [1][2]	Product status [3]	Definition
Objective [short] data sheet	Development	This document contains data from the objective specification for product development.
Preliminary [short] data sheet	Qualification	This document contains data from the preliminary specification.
Product [short] data sheet	Production	This document contains the product specification.

- [1] Please consult the most recently issued document before initiating or completing a design.
- [2] The term 'short data sheet' is explained in section "Definitions".
- [3] The product status of device(s) described in this document may have changed since this document was published and may differ in case of multiple devices. The latest product status information is available on the internet at <https://www.nexperia.com>.

Definitions

Draft — The document is a draft version only. The content is still under internal review and subject to formal approval, which may result in modifications or additions. Nexperia does not give any representations or warranties as to the accuracy or completeness of information included herein and shall have no liability for the consequences of use of such information.

Short data sheet — A short data sheet is an extract from a full data sheet with the same product type number(s) and title. A short data sheet is intended for quick reference only and should not be relied upon to contain detailed and full information. For detailed and full information see the relevant full data sheet, which is available on request via the local Nexperia sales office. In case of any inconsistency or conflict with the short data sheet, the full data sheet shall prevail.

Product specification — The information and data provided in a Product data sheet shall define the specification of the product as agreed between Nexperia and its customer, unless Nexperia and customer have explicitly agreed otherwise in writing. In no event however, shall an agreement be valid in which the Nexperia product is deemed to offer functions and qualities beyond those described in the Product data sheet.

Disclaimers

Limited warranty and liability — Information in this document is believed to be accurate and reliable. However, Nexperia does not give any representations or warranties, expressed or implied, as to the accuracy or completeness of such information and shall have no liability for the consequences of use of such information. Nexperia takes no responsibility for the content in this document if provided by an information source outside of Nexperia.

In no event shall Nexperia be liable for any indirect, incidental, punitive, special or consequential damages (including - without limitation - lost profits, lost savings, business interruption, costs related to the removal or replacement of any products or rework charges) whether or not such damages are based on tort (including negligence), warranty, breach of contract or any other legal theory.

Notwithstanding any damages that customer might incur for any reason whatsoever, Nexperia's aggregate and cumulative liability towards customer for the products described herein shall be limited in accordance with the Terms and conditions of commercial sale of Nexperia.

Right to make changes — Nexperia reserves the right to make changes to information published in this document, including without limitation specifications and product descriptions, at any time and without notice. This document supersedes and replaces all information supplied prior to the publication hereof.

Suitability for use — Nexperia products are not designed, authorized or warranted to be suitable for use in life support, life-critical or safety-critical systems or equipment, nor in applications where failure or malfunction of an Nexperia product can reasonably be expected to result in personal

injury, death or severe property or environmental damage. Nexperia and its suppliers accept no liability for inclusion and/or use of Nexperia products in such equipment or applications and therefore such inclusion and/or use is at the customer's own risk.

Quick reference data — The Quick reference data is an extract of the product data given in the Limiting values and Characteristics sections of this document, and as such is not complete, exhaustive or legally binding.

Applications — Applications that are described herein for any of these products are for illustrative purposes only. Nexperia makes no representation or warranty that such applications will be suitable for the specified use without further testing or modification.

Customers are responsible for the design and operation of their applications and products using Nexperia products, and Nexperia accepts no liability for any assistance with applications or customer product design. It is customer's sole responsibility to determine whether the Nexperia product is suitable and fit for the customer's applications and products planned, as well as for the planned application and use of customer's third party customer(s). Customers should provide appropriate design and operating safeguards to minimize the risks associated with their applications and products.

Nexperia does not accept any liability related to any default, damage, costs or problem which is based on any weakness or default in the customer's applications or products, or the application or use by customer's third party customer(s). Customer is responsible for doing all necessary testing for the customer's applications and products using Nexperia products in order to avoid a default of the applications and the products or of the application or use by customer's third party customer(s). Nexperia does not accept any liability in this respect.

Limiting values — Stress above one or more limiting values (as defined in the Absolute Maximum Ratings System of IEC 60134) will cause permanent damage to the device. Limiting values are stress ratings only and (proper) operation of the device at these or any other conditions above those given in the Recommended operating conditions section (if present) or the Characteristics sections of this document is not warranted. Constant or repeated exposure to limiting values will permanently and irreversibly affect the quality and reliability of the device.

Terms and conditions of commercial sale — Nexperia products are sold subject to the general terms and conditions of commercial sale, as published at <http://www.nexperia.com/profile/terms>, unless otherwise agreed in a valid written individual agreement. In case an individual agreement is concluded only the terms and conditions of the respective agreement shall apply. Nexperia hereby expressly objects to applying the customer's general terms and conditions with regard to the purchase of Nexperia products by customer.

No offer to sell or license — Nothing in this document may be interpreted or construed as an offer to sell products that is open for acceptance or the grant, conveyance or implication of any license under any copyrights, patents or other industrial or intellectual property rights.

Export control — This document as well as the item(s) described herein may be subject to export control regulations. Export might require a prior authorization from competent authorities.

Non-automotive qualified products — Unless this data sheet expressly states that this specific Nexperia product is automotive qualified, the product is not suitable for automotive use. It is neither qualified nor tested in accordance with automotive testing or application requirements. Nexperia accepts no liability for inclusion and/or use of non-automotive qualified products in automotive equipment or applications.

In the event that customer uses the product for design-in and use in automotive applications to automotive specifications and standards, customer (a) shall use the product without Nexperia's warranty of the product for such automotive applications, use and specifications, and (b) whenever customer uses the product for automotive applications beyond Nexperia's specifications such use shall be solely at customer's own risk, and (c) customer fully indemnifies Nexperia for any liability, damages or failed product claims resulting from customer design and use of the product for automotive applications beyond Nexperia's standard warranty and Nexperia's product specifications.

Translations — A non-English (translated) version of a document is for reference only. The English version shall prevail in case of any discrepancy between the translated and English versions.

Trademarks

Notice: All referenced brands, product names, service names and trademarks are the property of their respective owners.

Contents

1. General description	1
2. Features and benefits	1
3. Applications	1
4. Ordering information	2
5. Marking	2
6. Block diagram	2
7. Pinning information	3
7.1. Pinning.....	3
7.2. Pin description.....	3
8. Limiting values	4
9. ESD ratings	4
10. Recommended operating conditions	4
11. Thermal characteristics	4
12. Electrical characteristics	5
12.1. Typical characteristics graphs.....	6
12.2. Typical waveforms.....	8
13. Feature description	9
14. Application information	13
15. Package outline	16
16. Abbreviations	17
17. Revision history	17
18. Legal information	18

© Nexperia B.V. 2026. All rights reserved

For more information, please visit: <http://www.nexperia.com>

For sales office addresses, please send an email to: salesaddresses@nexperia.com

Date of release: 16 January 2026