

DF2002S thru DF2010S

Bridge Rectifiers

Reverse Voltage 200V to 1000V Forward Current 2.0A

Features

- Glass passivated bridge rectifiers
- Ideal for automated placement
- High surge current capability
- Moisture sensitivity: level 1, per J-STD-020
- High temperature soldering guaranteed: 260°C/10 seconds



DFS

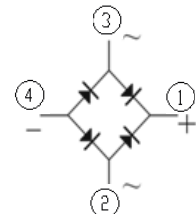

Schematic Diagram

Mechanical Data

- Case: DFS, molding compound meets UL 94V-0 flammability rating

Applications

General purpose use in ac-to dc bridge full wave rectification for SMPS, lighting, adapter, charger, home appliances, office equipment, and telecommunication applications

Maximum Ratings & Electrical Characteristics (T_A=25°C unless otherwise noted)

Parameter	Symbol	DF2002S	DF2006S	DF2008S	DF2010S	Unit
Maximum Repetitive Peak Reverse Voltage	V _{RRM}	200	600	800	1000	V
Maximum RMS Voltage	V _{RMS}	140	420	560	700	V
Maximum DC Blocking Voltage	V _{DC}	200	600	800	1000	V
Maximum Average Forward Output Rectified Current	I _{F(AV)}	2.0				A
Peak Forward Surge Current 8.3 ms Single Half Sine-Wave Superimposed on Rated Load	I _{FSM}	60				A
Rating for Fusing (t≤8.3ms)	I ² t	15.0				A ² sec
Maximum Instantaneous Forward Voltage	V _F	1A	1.0			V
		2A	1.1			
Maximum DC Reverse Current at Rated DC Blocking Voltage	I _R	T _A =25°C	5			µA
		T _A =125°C	50			
Typical Reverse Recovery Time	T _{rr}	I _F =0.5A, I _R =1.0A, I _{rr} =0.25A	2.0			µs
Typical Junction Capacitance at 4.0V, 1MHz	C _J	15.9			pF	
Typical Thermal Resistance, Junction to Ambient ¹	R _{θJA}	32			°C/W	
Typical Thermal Resistance, Junction to Case ¹	R _{θJC}	11				
Operating Junction and Storage Temperature Range	T _J , T _{STG}	-55 to +150				°C

Note:

1. Device mounted P.C.B with 13x13mm copper pads, 2 OZ, FR4 PCB.

Ratings and Characteristics Curves ($T_A=25^\circ\text{C}$ unless otherwise noted)

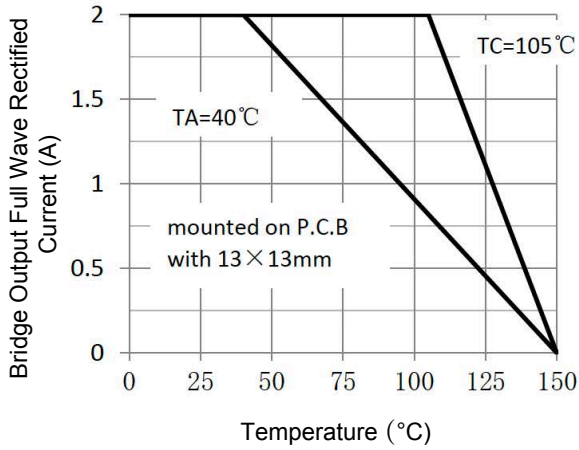

Figure 1. Forward Current Derating Curve

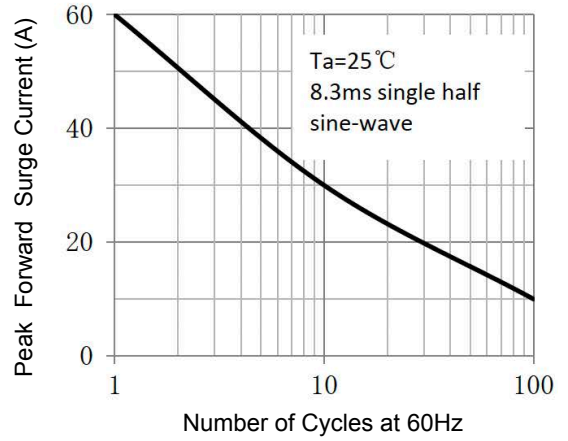

Figure 2. Maximum Non-Repetitive Peak Forward Surge Current

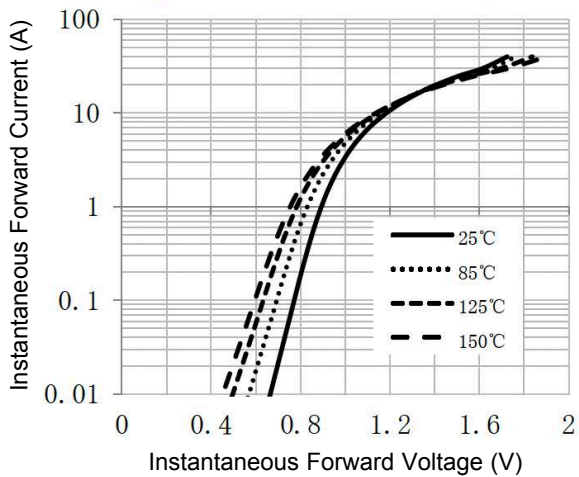

Figure 3. Typical Instantaneous Forward Characteristics

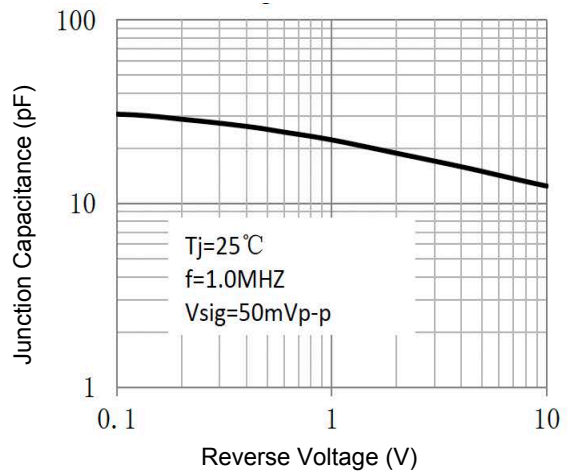

Figure 4. Typical Junction Capacitance

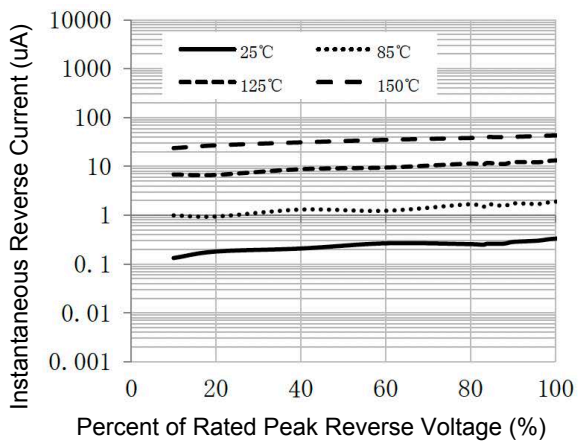
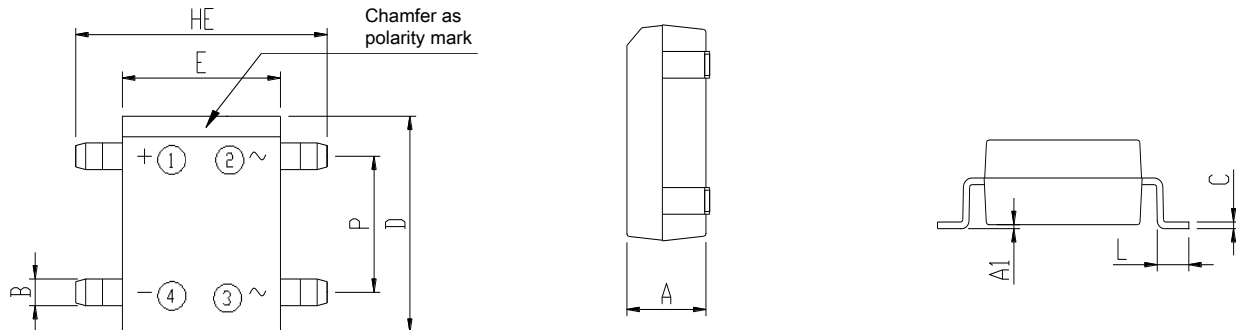

Figure 5. Typical Reverse Characteristics

Package Outline Dimensions (DFS)



Symbol	Dimensions In Millimeters		Dimensions In Inches	
	Min	Max	Min	Max
A	3.050	3.300	0.120	0.130
A1	0.076	0.330	0.003	0.013
B	1.020	1.200	0.040	0.047
C	0.220	0.330	0.009	0.013
D	8.000	8.510	0.315	0.335
E	6.200	6.500	0.244	0.256
HE	9.800	10.300	0.386	0.406
L	1.020	1.520	0.040	0.060
P	5.000	5.200	0.197	0.205

Recommended Pad Layout

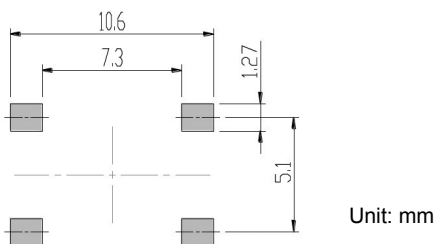

Order Information

Device	Package	Marking	Carrier	Quantity
DF2002S	DFS	DF2002S	Tape & Reel	1,500pcs / Reel
DF2006S	DFS	DF2006S	Tape & Reel	1,500pcs / Reel
DF2008S	DFS	DF2008S	Tape & Reel	1,500pcs / Reel
DF2010S	DFS	DF2010S	Tape & Reel	1,500pcs / Reel