

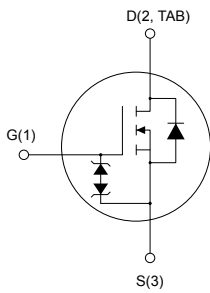

STF10N105K5, STP10N105K5, STW10N105K5

Datasheet

N-channel 1050 V, 1 Ω typ., 6 A MDmesh K5 Power MOSFET in a TO-220FP, TO-220 and TO-247 packages

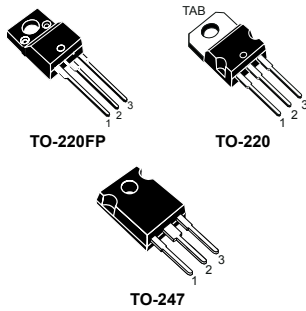

AM01476v1_tab



Features

Order code	V_{DS}	$R_{DS(on)}$ max.	I_D
STF10N105K5	1050 V	1.3 Ω	6 A
STP10N105K5			
STW10N105K5			

- Ultra-low gate charge
- Very low FoM (figure of merit)
- Zener-protected
- 100% avalanche tested

Applications

- Switching applications

Description

These very high voltage N-channel Power MOSFETs are designed using MDmesh K5 technology based on an innovative proprietary vertical structure. The result is a dramatic reduction in on-resistance and ultra-low gate charge for applications requiring superior power density and high efficiency.

Product status link

[STF10N105K5](#)

[STP10N105K5](#)

[STW10N105K5](#)

1 Electrical ratings

Table 1. Absolute maximum ratings

Symbol	Parameter	Value			Unit
		TO-220	TO-247	TO-220FP	
V_{GS}	Gate-source voltage	30			V
I_D	Drain current (continuous) at $T_C = 25\text{ °C}$	6			A
	Drain current (continuous) at $T_C = 100\text{ °C}$	3.78			
$I_{DM}^{(1)}$	Drain current (pulsed)	24			A
P_{TOT}	Total power dissipation at $T_C = 25\text{ °C}$	130		30	W
V_{ISO}	Insulation withstand voltage (RMS) from all three leads to external heat sink ($t = 1\text{ s}$; $T_C = 25\text{ °C}$)	-		2.5	kV
$dv/dt^{(2)}$	Peak diode recovery voltage slope	4.5			V/ns
$dv/dt^{(3)}$	MOSFET dv/dt ruggedness	50			V/ns
T_{stg}	Storage temperature range	-55 to 150			°C
T_J	Operating junction temperature range				°C

1. Pulse width is limited by safe operating area.
2. $I_{SD} \leq 6\text{ A}$, $di/dt = 100\text{ A}/\mu\text{s}$, $V_{DS}(\text{peak}) < V_{(BR)DSS}$.
3. $V_{DD} \leq 840\text{ V}$.

Table 2. Thermal data

Symbol	Parameter	Value			Unit
		TO-220	TO-247	TO-220FP	
R_{thJC}	Thermal resistance, junction-to-case	0.96			°C/W
R_{thJA}	Thermal resistance, junction-to-ambient	62.5	50	62.5	°C/W

Table 3. Avalanche characteristics

Symbol	Parameter	Value	Unit
I_{AR}	Avalanche current, repetitive or non-repetitive (pulse width limited by T_J max.)	2	A
E_{AS}	Single pulse avalanche energy (starting $T_J = 25\text{ °C}$, $I_D = I_{AR}$, $V_{DD} = 50\text{ V}$)	140	mJ

2 Electrical characteristics

$T_C = 25\text{ }^\circ\text{C}$ unless otherwise specified.

Table 4. Static

Symbol	Parameter	Test conditions	Min.	Typ.	Max.	Unit
$V_{(BR)DSS}$	Drain-source breakdown voltage	$V_{GS} = 0\text{ V}$, $I_D = 1\text{ mA}$	1050	-	-	V
I_{DSS}	Zero gate voltage drain current	$V_{GS} = 0\text{ V}$, $V_{DS} = 1050\text{ V}$	-	-	1	μA
		$V_{GS} = 0\text{ V}$, $V_{DS} = 1050\text{ V}$, $T_C = 125\text{ }^\circ\text{C}^{(1)}$	-	-	50	
I_{GSS}	Gate-body leakage current	$V_{DS} = 0\text{ V}$, $V_{GS} = \pm 20\text{ V}$	-	-	± 10	μA
$V_{GS(th)}$	Gate threshold voltage	$V_{DS} = V_{GS}$, $I_D = 100\text{ }\mu\text{A}$	3	4	5	V
$R_{DS(on)}$	Static drain-source on-resistance	$V_{GS} = 10\text{ V}$, $I_D = 3\text{ A}$	-	1	1.3	Ω

1. Specified by design, not tested in production.

Table 5. Dynamic

Symbol	Parameter	Test conditions	Min.	Typ.	Max.	Unit
C_{iss}	Input capacitance	$V_{DS} = 100\text{ V}$, $f = 1\text{ MHz}$, $V_{GS} = 0\text{ V}$	-	545	-	pF
C_{oss}	Output capacitance		-	30	-	pF
C_{rss}	Reverse transfer capacitance		-	1.3	-	pF
$C_{o(tr)}^{(1)}$	Equivalent output capacitance time related	$V_{DS} = 0$ to 840 V , $V_{GS} = 0\text{ V}$	-	65	-	pF
$C_{o(er)}^{(2)}$	Equivalent output capacitance energy related	$V_{DS} = 0$ to 840 V , $V_{GS} = 0\text{ V}$	-	22	-	pF
R_g	Intrinsic gate resistance	$f = 1\text{ MHz}$, $I_D = 0\text{ A}$	-	7	-	Ω
Q_g	Total gate charge	$V_{DD} = 840\text{ V}$, $I_D = 6\text{ A}$, $V_{GS} = 0$ to 10 V (see the Figure 18. Test circuit for gate charge behavior)	-	21.5	-	nC
Q_{gs}	Gate-source charge		-	3.3	-	nC
Q_{gd}	Gate-drain charge		-	15.5	-	nC

1. $C_{o(tr)}$ is a constant capacitance value that gives the same charging time as C_{oss} while V_{DS} is rising from 0 to 80% V_{DSS} .

2. $C_{o(er)}$ is a constant capacitance value that gives the same stored energy as C_{oss} while V_{DS} is rising from 0 to 80% V_{DSS} .

Table 6. Switching times

Symbol	Parameter	Test conditions	Min.	Typ.	Max.	Unit
$t_{d(on)}$	Turn-on delay time	$V_{DD} = 525\text{ V}$, $I_D = 3\text{ A}$, $R_G = 4.7\text{ }\Omega$, $V_{GS} = 10\text{ V}$	-	19	-	ns
t_r	Rise time		-	8	-	ns
$t_{d(off)}$	Turn-off delay time	(see the Figure 17. Test circuit for resistive load switching times and Figure 22. Switching time waveform)	-	50	-	ns
t_f	Fall time		-	21.5	-	ns

Table 7. Source-drain diode

Symbol	Parameter	Test conditions	Min.	Typ.	Max.	Unit
I_{SD}	Source-drain current		-	-	6	A
$I_{SDM}^{(1)}$	Source-drain current (pulsed)		-	-	24	A
$V_{SD}^{(2)}$	Forward on voltage	$V_{GS} = 0\text{ V}$, $I_{SD} = 6\text{ A}$	-	-	1.5	V
t_{rr}	Reverse recovery time	$I_{SD} = 6\text{ A}$, $di/dt = 100\text{ A}/\mu\text{s}$,	-	345	-	ns
Q_{rr}	Reverse recovery charge	$V_{DD} = 60\text{ V}$	-	3.53	-	μC
I_{RRM}	Reverse recovery current	(see the Figure 19. Test circuit for inductive load switching and diode recovery times)	-	20.5	-	A
t_{rr}	Reverse recovery time	$I_{SD} = 6\text{ A}$, $di/dt = 100\text{ A}/\mu\text{s}$,	-	540	-	ns
Q_{rr}	Reverse recovery charge	$V_{DD} = 60\text{ V}$, $T_J = 150\text{ }^\circ\text{C}$	-	5.05	-	μC
I_{RRM}	Reverse recovery current	(see the Figure 19. Test circuit for inductive load switching and diode recovery times)	-	18.5	-	A

1. Pulse width is limited by safe operating area.
2. Pulse test: pulse duration = 300 μs , duty cycle 1.5%.

2.1 Electrical characteristics (curves)
Figure 1. Safe operating area for TO-220FP

Figure 2. Normalized transient thermal impedance for TO-220FP

Figure 3. Safe operating area for TO-220

Figure 4. Normalized transient thermal impedance for TO-220

Figure 5. Safe operating area for TO-247

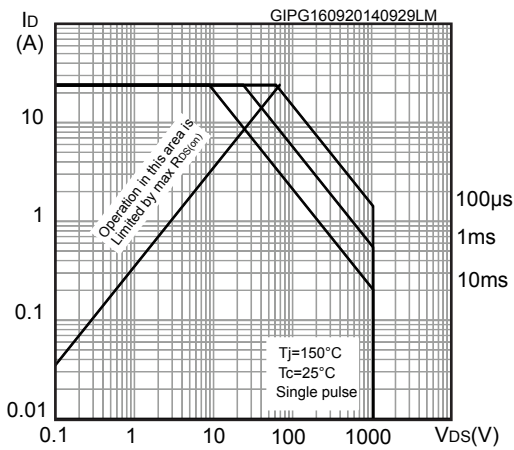
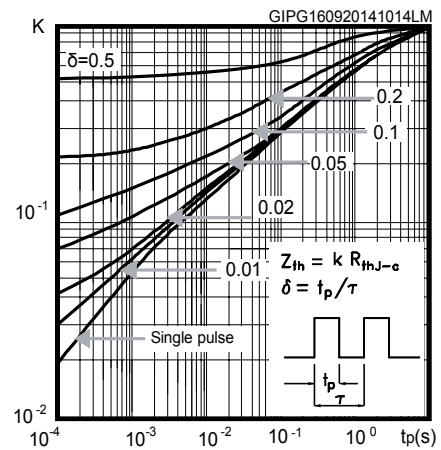
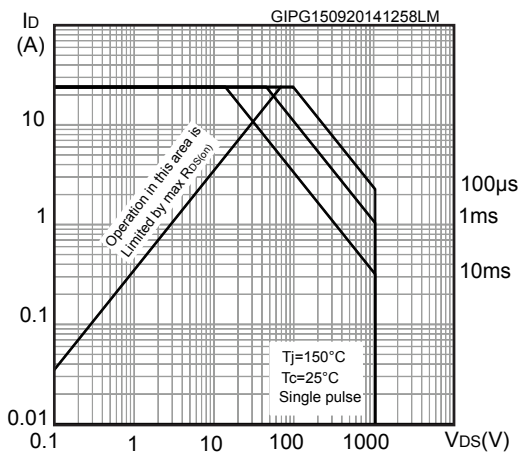
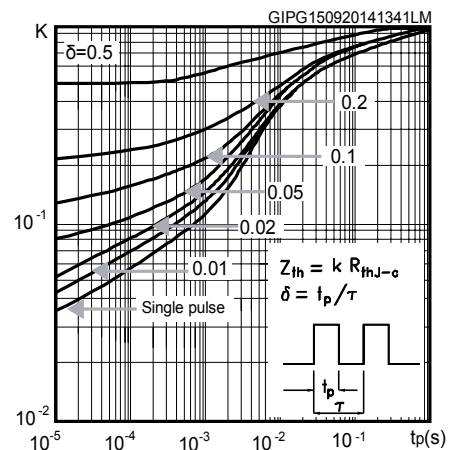
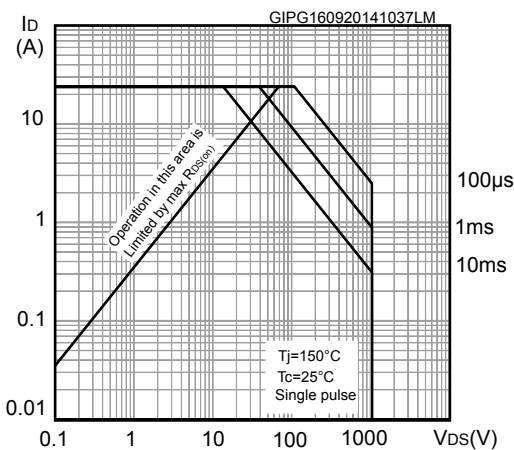
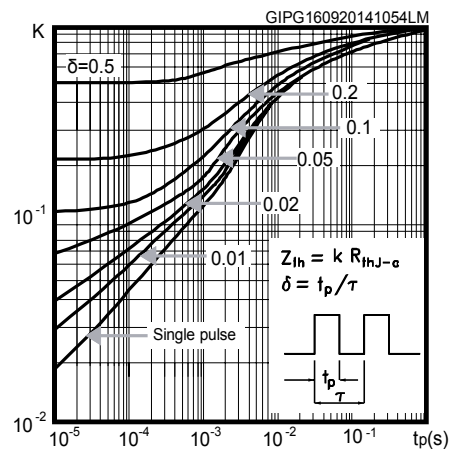
Figure 6. Normalized transient thermal impedance for TO-247

Figure 7. Typical output characteristics

Figure 8. Typical transfer characteristics

Figure 9. Typical gate charge characteristics

Figure 10. Typical drain-source on-resistance

Figure 11. Typical capacitance characteristics

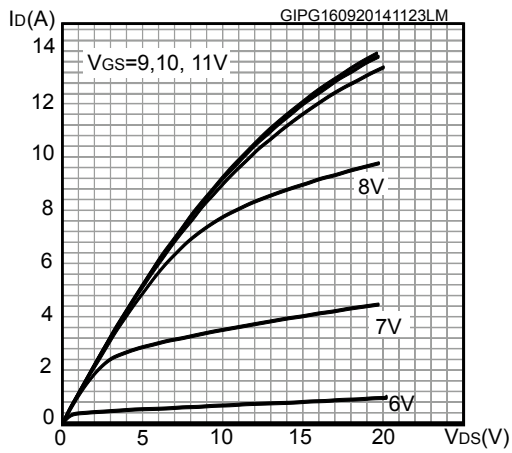
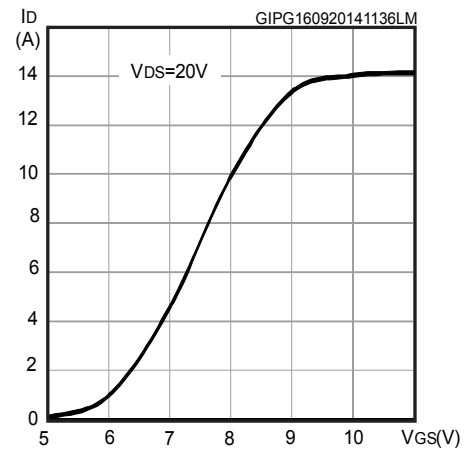
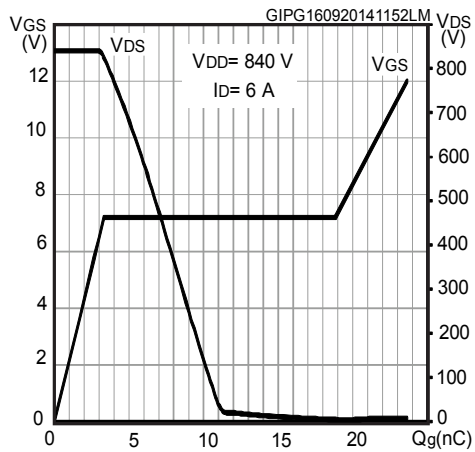
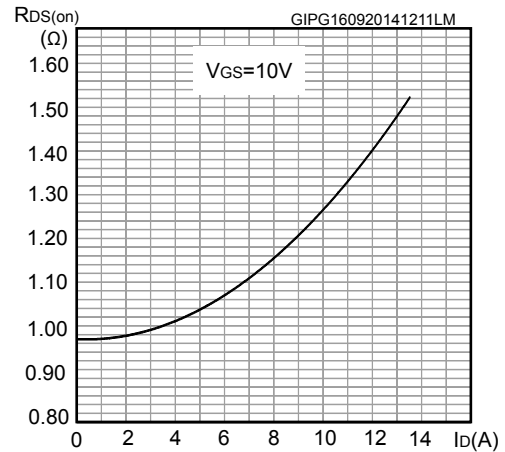
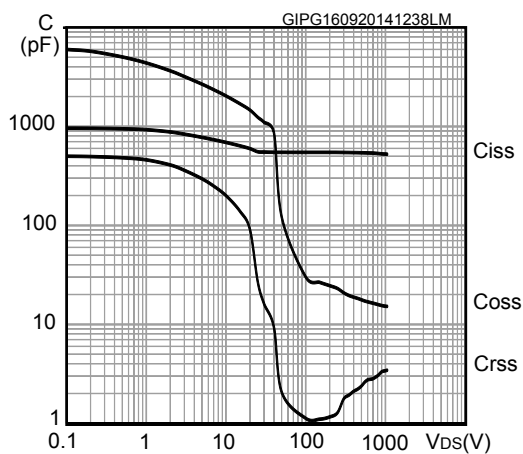
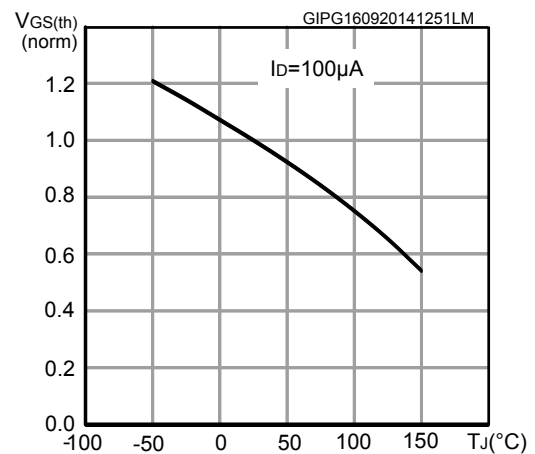
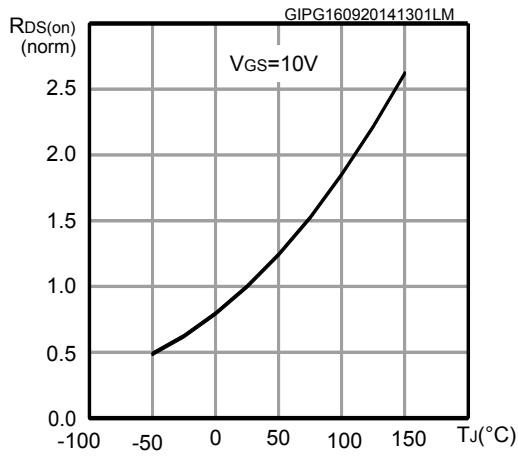
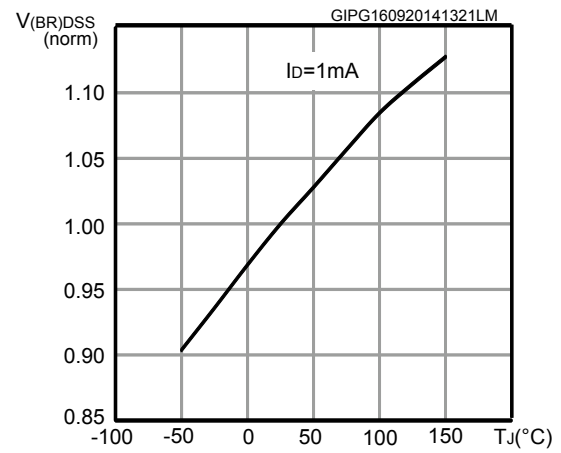
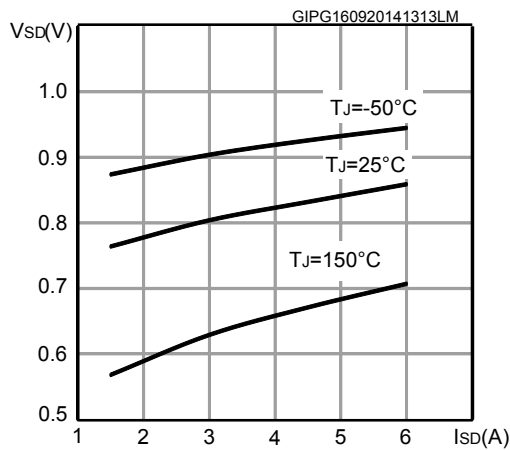
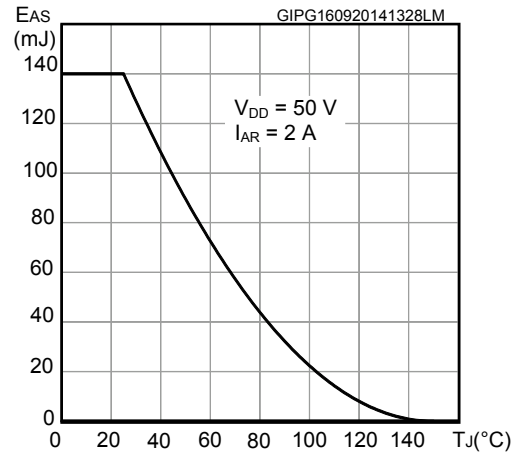
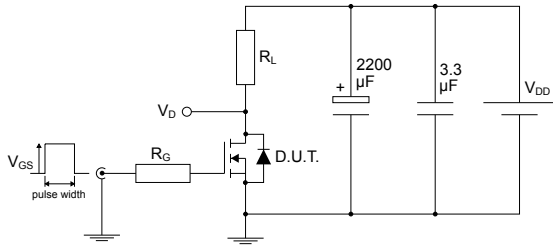
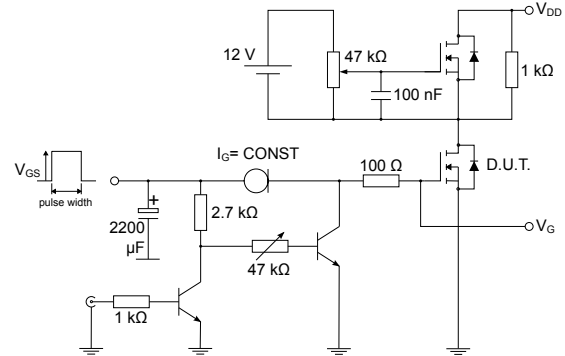
Figure 12. Normalized gate threshold vs temperature

Figure 13. Normalized on-resistance vs temperature

Figure 14. Normalized breakdown voltage vs temperature

Figure 15. Typical reverse diode forward characteristics

Figure 16. Maximum avalanche energy vs temperature

3 Test circuits

Figure 17. Test circuit for resistive load switching times

AM01468v1

Figure 18. Test circuit for gate charge behavior

AM01469v1

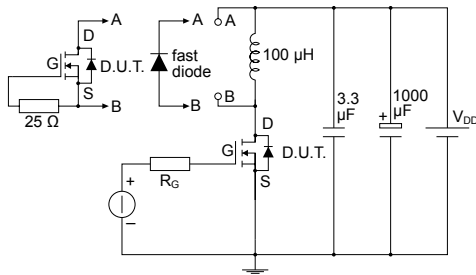
Figure 19. Test circuit for inductive load switching and diode recovery times

AM01470v1

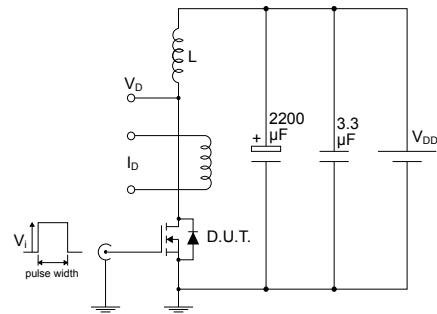
Figure 20. Unclamped inductive load test circuit

AM01471v1

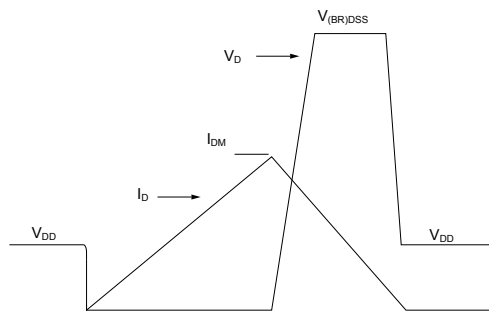
Figure 21. Unclamped inductive waveform

AM01472v1

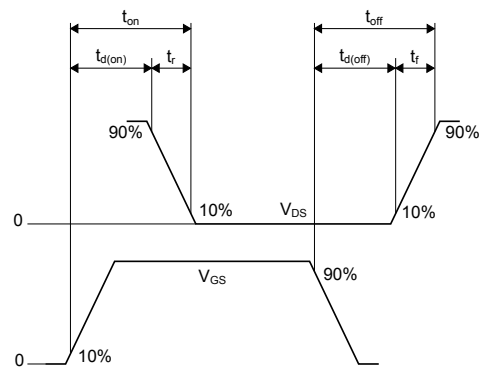
Figure 22. Switching time waveform

AM01473v1

4 Package information

To meet environmental requirements, ST offers these devices in different grades of **ECOPACK** packages, depending on their level of environmental compliance. ECOPACK specifications, grade definitions, and product status are available at: www.st.com. ECOPACK is an ST trademark.

4.1 TO-220FP type B package information

Figure 23. TO-220FP type B package outline

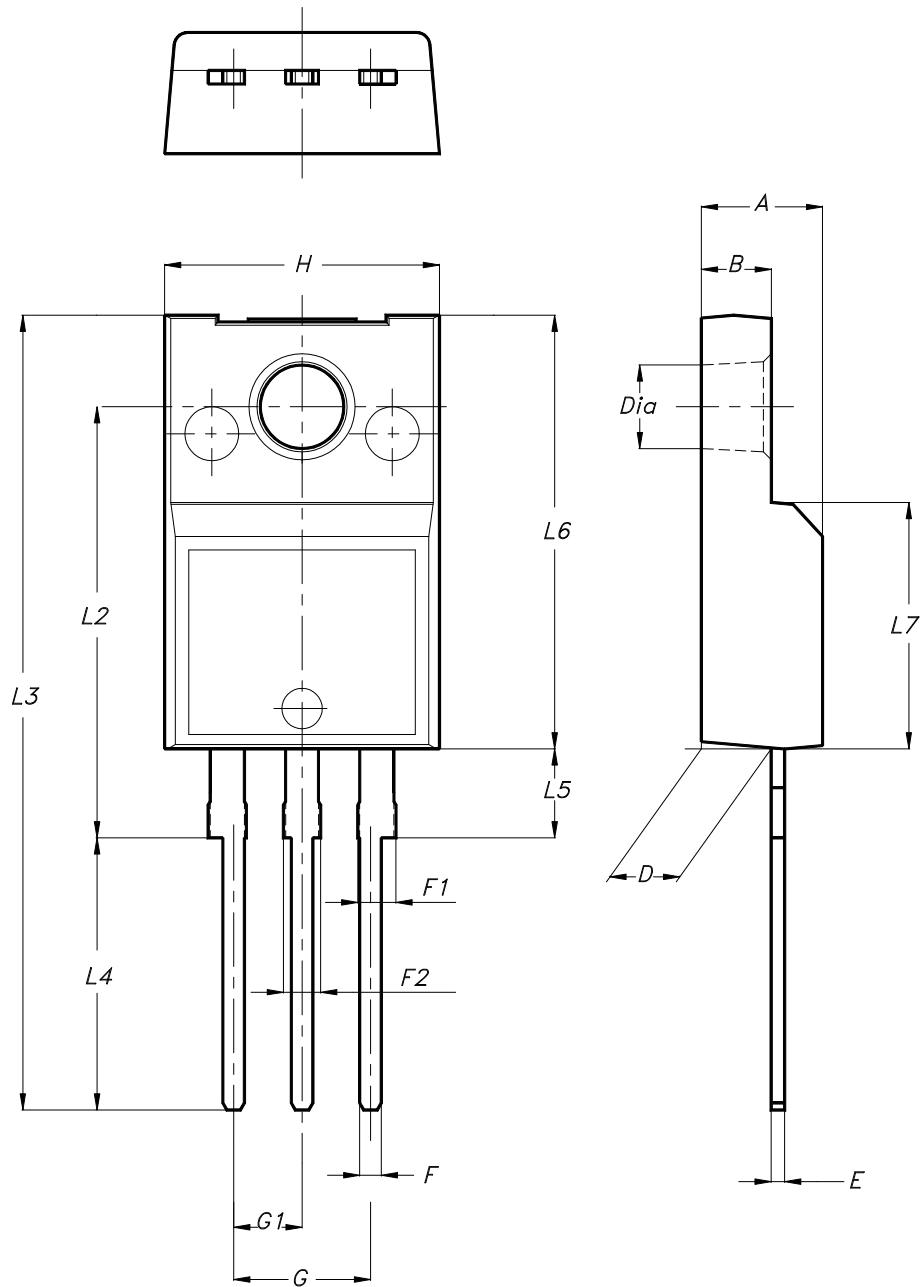

7012510_B_rev.14

Table 8. TO-220FP type B package mechanical data

Dim.	mm		
	Min.	Typ.	Max.
A	4.40		4.60
B	2.50		2.70
D	2.50		2.75
E	0.45		0.70
F	0.75		1.00
F1	1.15		1.70
F2	1.15		1.70
G	4.95		5.20
G1	2.40		2.70
H	10.00		10.40
L2		16.00	
L3	28.60		30.60
L4	9.80		10.60
L5	2.90		3.60
L6	15.90		16.40
L7	9.00		9.30
Dia	3.00		3.20

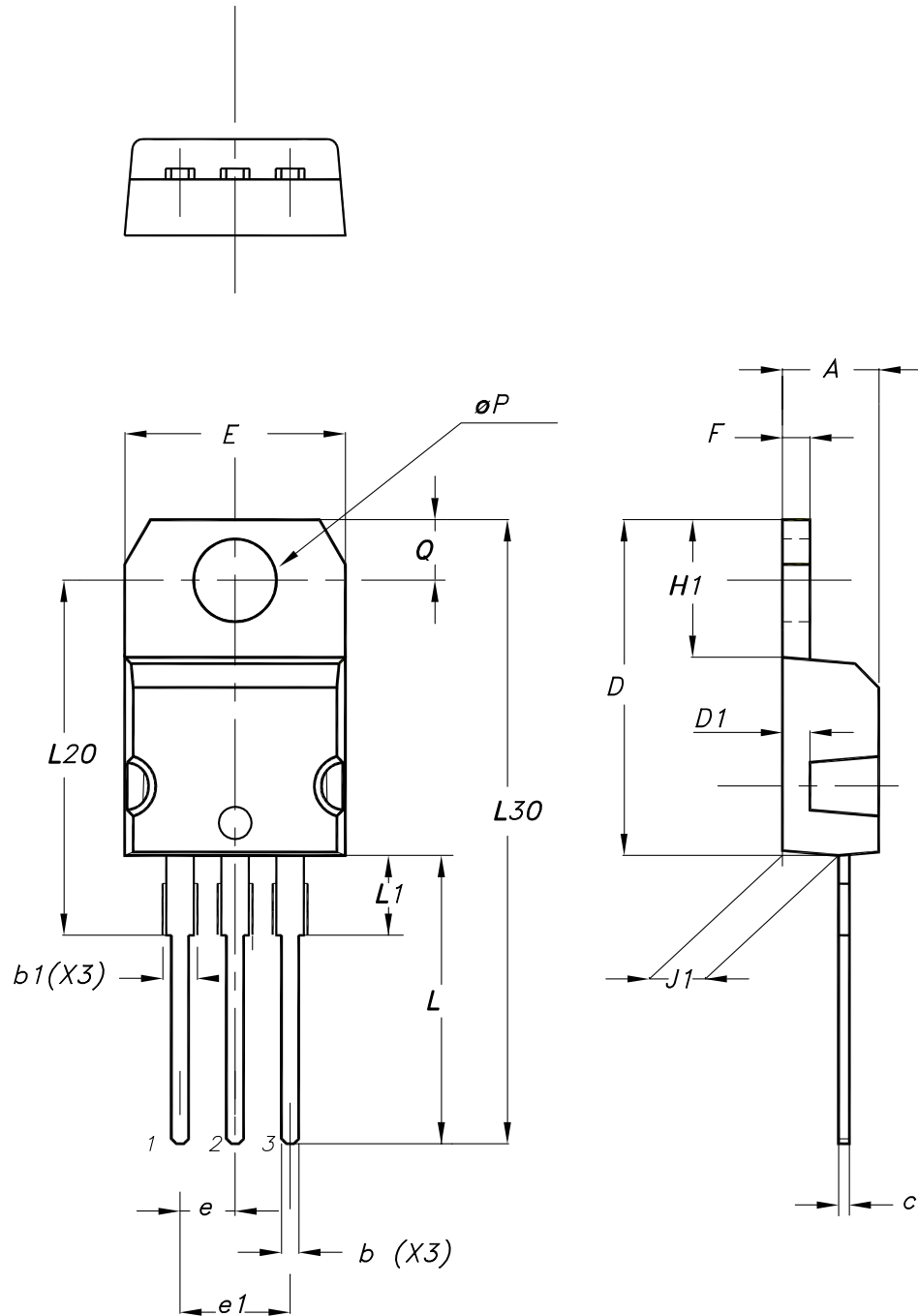
4.2 TO-220 type A package information
Figure 24. TO-220 type A package outline

0015988_typeA_Rev_24

Table 9. TO-220 type A package mechanical data

Dim.	mm		
	Min.	Typ.	Max.
A	4.40		4.60
b	0.61		0.88
b1	1.14		1.55
c	0.48		0.70
D	15.25		15.75
D1		1.27	
E	10.00		10.40
e	2.40		2.70
e1	4.95		5.15
F	1.23		1.32
H1	6.20		6.60
J1	2.40		2.72
L	13.00		14.00
L1	3.50		3.93
L20		16.40	
L30		28.90	
øP	3.75		3.85
Q	2.65		2.95
Slug flatness		0.03	0.10

Table 10. TO-247 package mechanical data

Dim.	mm		
	Min.	Typ.	Max.
A	4.85		5.15
A1	2.20		2.60
A2		1.27	
b	1.0		1.40
b1	2.0		2.40
b2	3.0		3.40
c	0.40		0.80
D	19.85		20.15
E	15.45		15.75
e	5.30	5.45	5.60
L	14.20		14.80
L1	3.70		4.30
L2		18.50	
ØP	3.55		3.65
ØR	4.50		5.50
S	5.30	5.50	5.70



5 Ordering information

Table 11. Order codes

Order codes	Marking	Package	Packing
STF10N105K5	10N105K5	TO-220FP	Tube
STP10N105K5		TO-220	
STW10N105K5		TO-247	

Revision history

Table 12. Document revision history

Date	Revision	Changes
07-Oct-2014	1	First release.
14-Oct-2014	2	Document status promoted from preliminary to production data.
14-Jan-2026	3	Updated Section 4: Package information . Minor text changes.



Contents

1	Electrical ratings	2
2	Electrical characteristics	3
2.1	Electrical characteristics (curves)	5
3	Test circuits	8
4	Package information	9
4.1	TO-220FP type B package information	9
4.2	TO-220 type A package information	11
4.3	TO-247 package information	13
5	Ordering information	15
	Revision history	16



IMPORTANT NOTICE – READ CAREFULLY

STMicroelectronics NV and its subsidiaries (“ST”) reserve the right to make changes, corrections, enhancements, modifications, and improvements to ST products and/or to this document at any time without notice.

In the event of any conflict between the provisions of this document and the provisions of any contractual arrangement in force between the purchasers and ST, the provisions of such contractual arrangement shall prevail.

The purchasers should obtain the latest relevant information on ST products before placing orders. ST products are sold pursuant to ST’s terms and conditions of sale in place at the time of order acknowledgment.

The purchasers are solely responsible for the choice, selection, and use of ST products and ST assumes no liability for application assistance or the design of the purchasers’ products.

No license, express or implied, to any intellectual property right is granted by ST herein.

Resale of ST products with provisions different from the information set forth herein shall void any warranty granted by ST for such product.

If the purchasers identify an ST product that meets their functional and performance requirements but that is not designated for the purchasers’ market segment, the purchasers shall contact ST for more information.

ST and the ST logo are trademarks of ST. For additional information about ST trademarks, refer to www.st.com/trademarks. All other product or service names are the property of their respective owners.

Information in this document supersedes and replaces information previously supplied in any prior versions of this document.

© 2026 STMicroelectronics – All rights reserved