

THIS DRAWING IS UNPUBLISHED. RELEASED FOR PUBLICATION 20
 © COPYRIGHT 20 BY - ALL RIGHTS RESERVED.

REVISIONS				
P	LTR	DESCRIPTION	DATE	APVD
A		RELEASE PER ECR-19-000700	16JAN2019	JS DD
A1		REVISED PER ECR-25-264392	20MAR2026	GIC MM

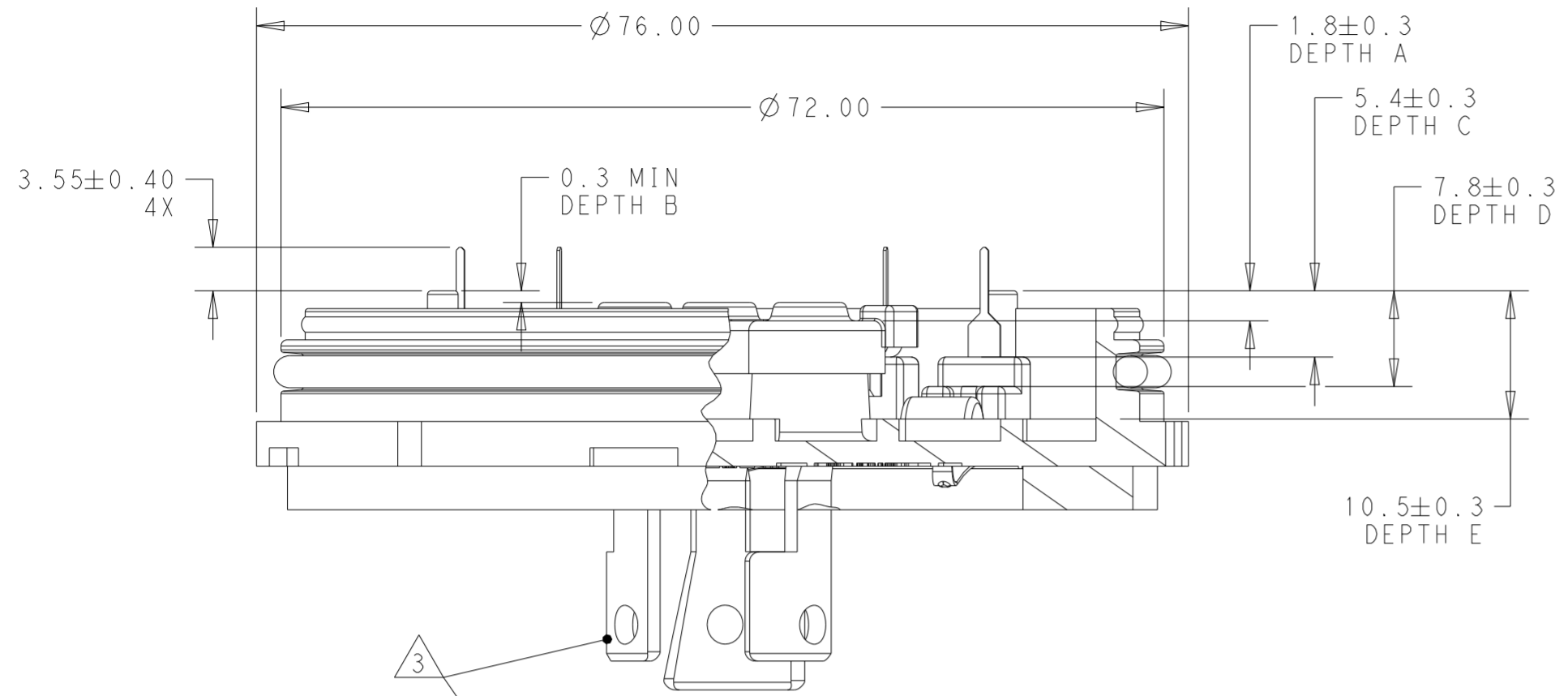

1 MATERIALS:
 HOUSING AND CAP: PBT
 DIMMING CONTACTS: COPPER ALLOY
 LINE VOLTAGE CONTACTS: COPPER ALLOY
 SHORTING CLIP: COPPER ALLOY
 GASKET: NBR/PVC BLEND
 O-RING: SILICONE RUBBER
 MEMBRANE VENT: PTFE

2 FINISH:
 DIMMING CONTACTS: NICKEL UNDERPLATE ENTIRE
 CONTACT 0.127 µm MIN THICK. SELECTIVE GOLD PLATE CONTACT
 MATING AREA (MATING FACE SIDE ONLY) 0.76 µm MIN THICK.
 MATTE TIN PLATE TAB ON BOTH SIDES 0.30 µm MIN THICK.
 LINE VOLTAGE CONTACTS: MATTE TIN PLATE

3 MATING INTERFACE PER ANSI C136.41-2013.

4 ADHESIVE BACKED GASKET SUPPLIED BUT NOT INSTALLED

5. THIS PRODUCT HAS NOT COMPLETED VALIDATION TESTING.

6 VENT FEATURES ONLY ON 1-2325661-1

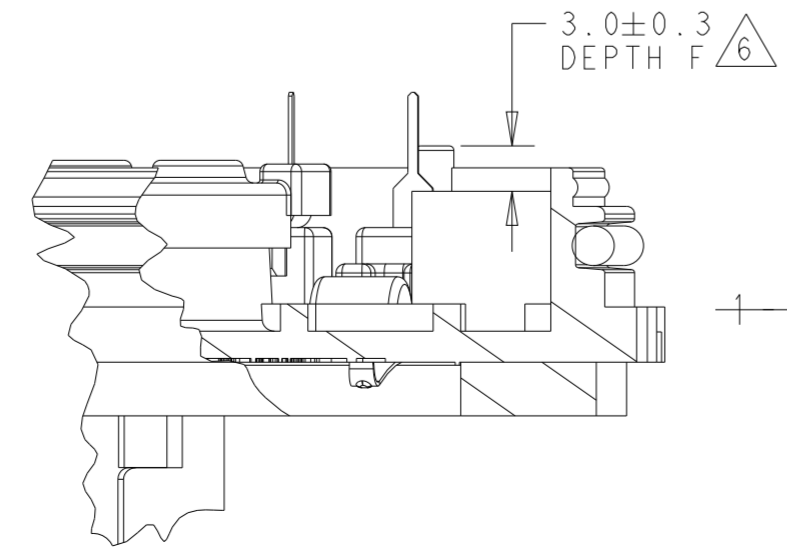
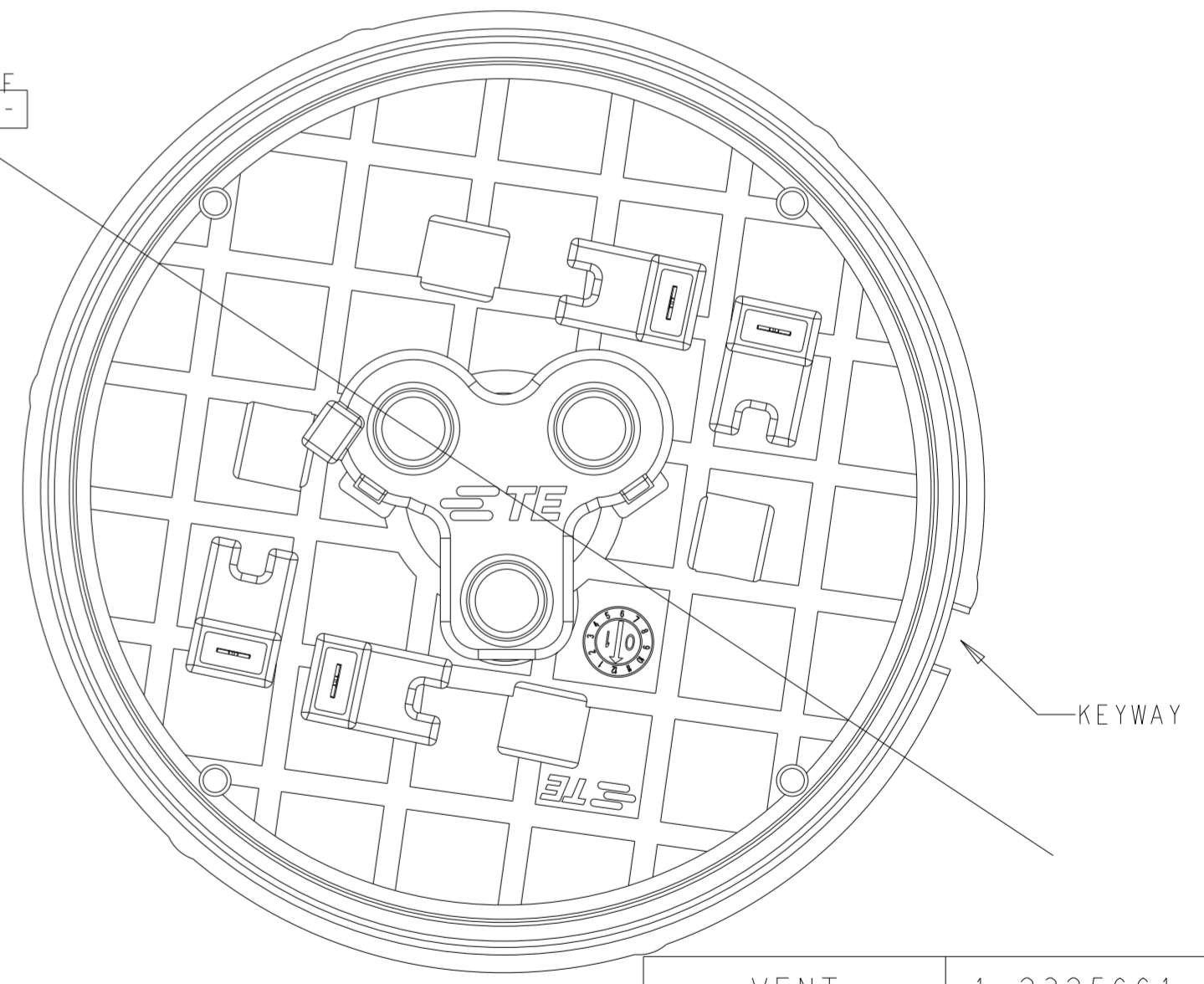
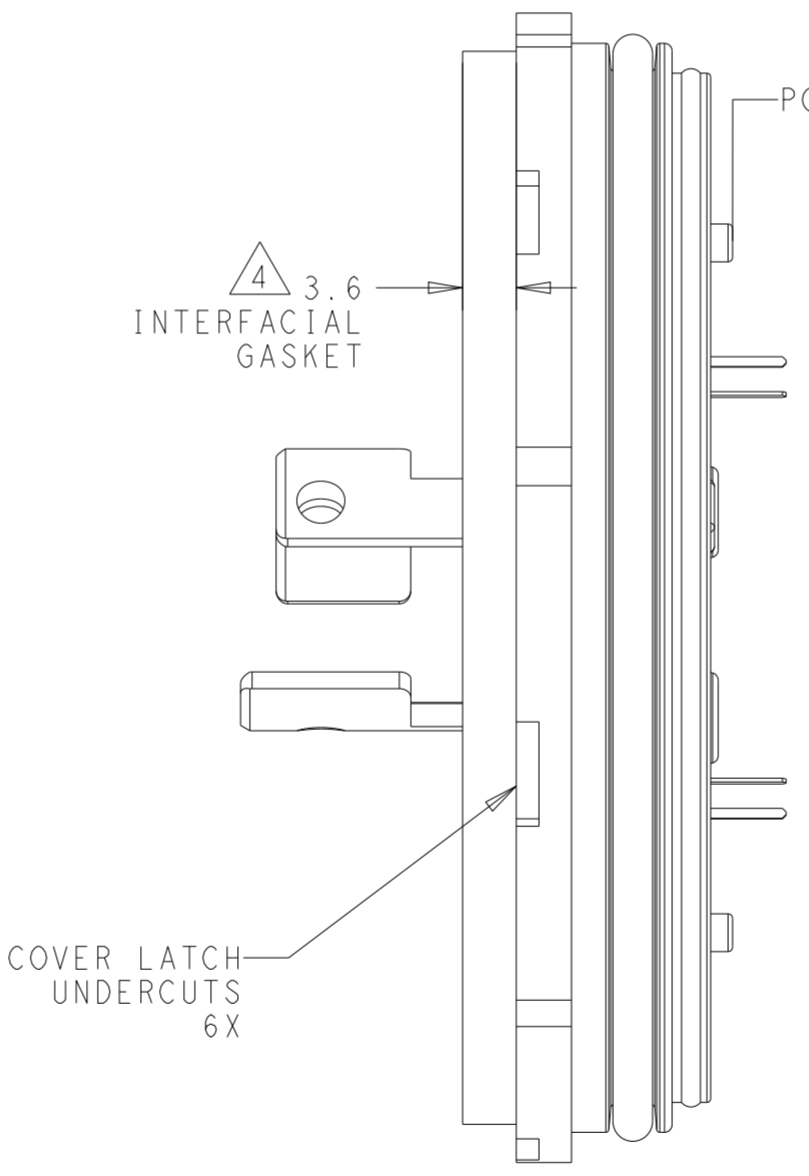
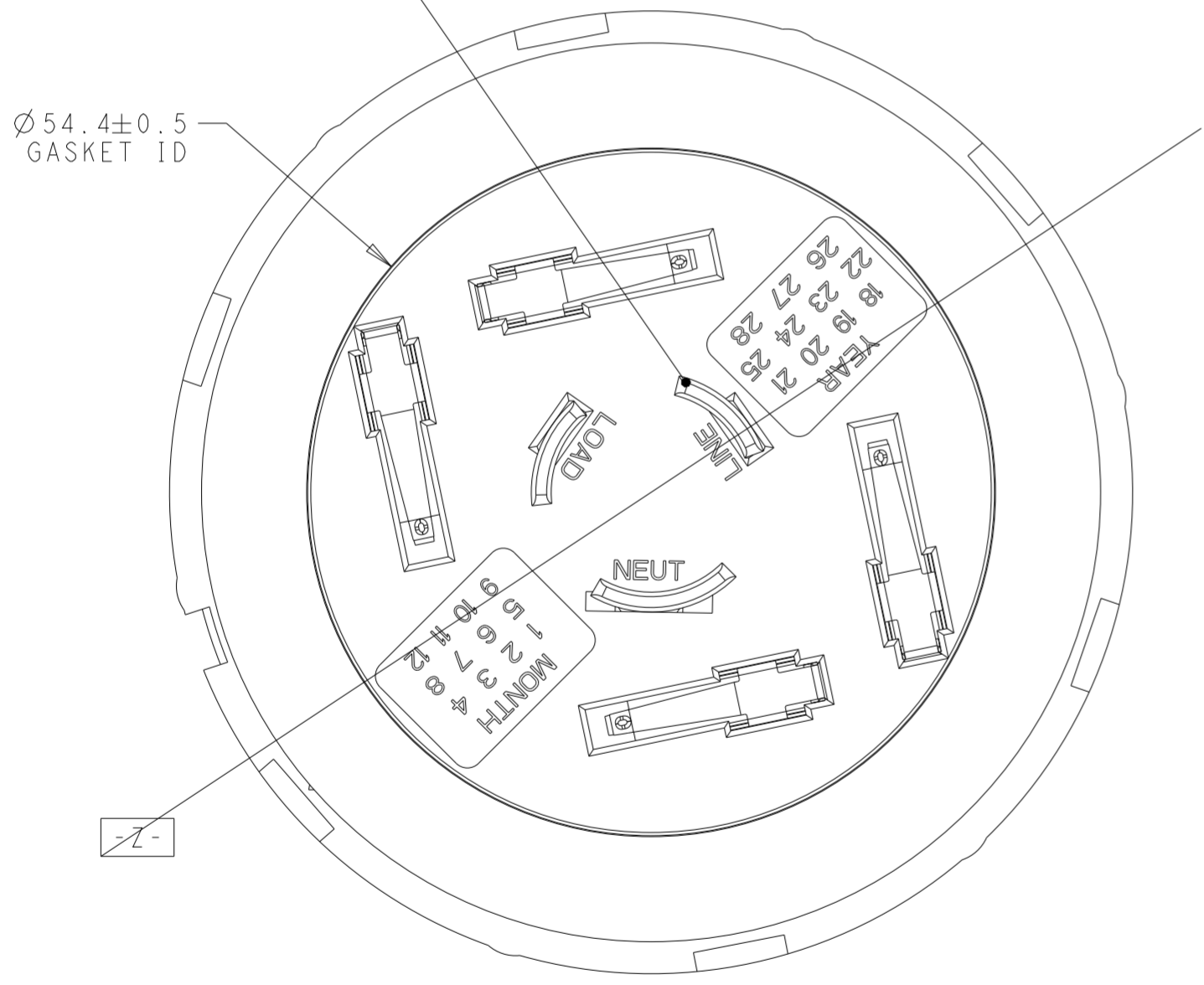

1-2325661-1 SHOWN

OBSOLETE	VENT	1-2325661-1
OBSOLETE	NO VENT	2325661-1
	NOTES	PART NO.

THIS DRAWING IS A CONTROLLED DOCUMENT.		DWN C DAILY 03OCT2017	TE Connectivity	
		CHK MOSTOLLER 03OCT2017		
DIMENSIONS:	TOLERANCES UNLESS OTHERWISE SPECIFIED:	APVD -	NAME SHORTING BASE ASSEMBLY, LUMAWISE ENDURANCE N	
mm	0 PLC ± 1 PLC ±0.2 2 PLC ±0.25 3 PLC ± 4 PLC ±	PRODUCT SPEC 108-32125	SIZE A2	
	ANGLES ± FINISH	APPLICATION SPEC 114-32159	CAGE CODE -	DRAWING NO C-2325661
MATERIAL 1	2	WEIGHT -	RESTRICTED TO -	
CUSTOMER DRAWING		SCALE 1:1	SHEET 1 OF 2	REV A1

THIS DRAWING IS UNPUBLISHED. RELEASED FOR PUBLICATION 20
 © COPYRIGHT 20 BY - ALL RIGHTS RESERVED.

REVISIONS				
P	LTR	DESCRIPTION	DATE	APVD
-	-	SEE SHEET 1	-	-

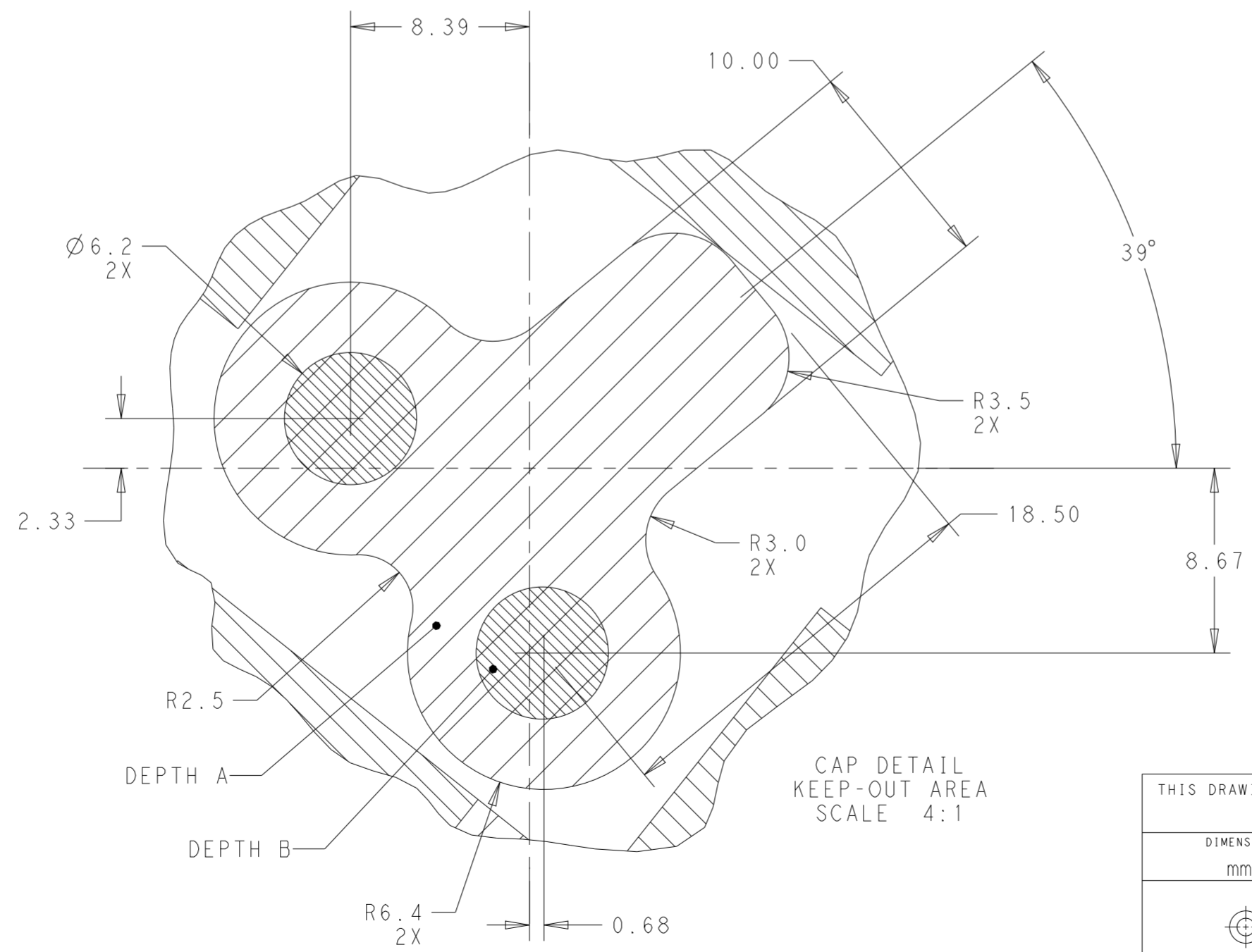
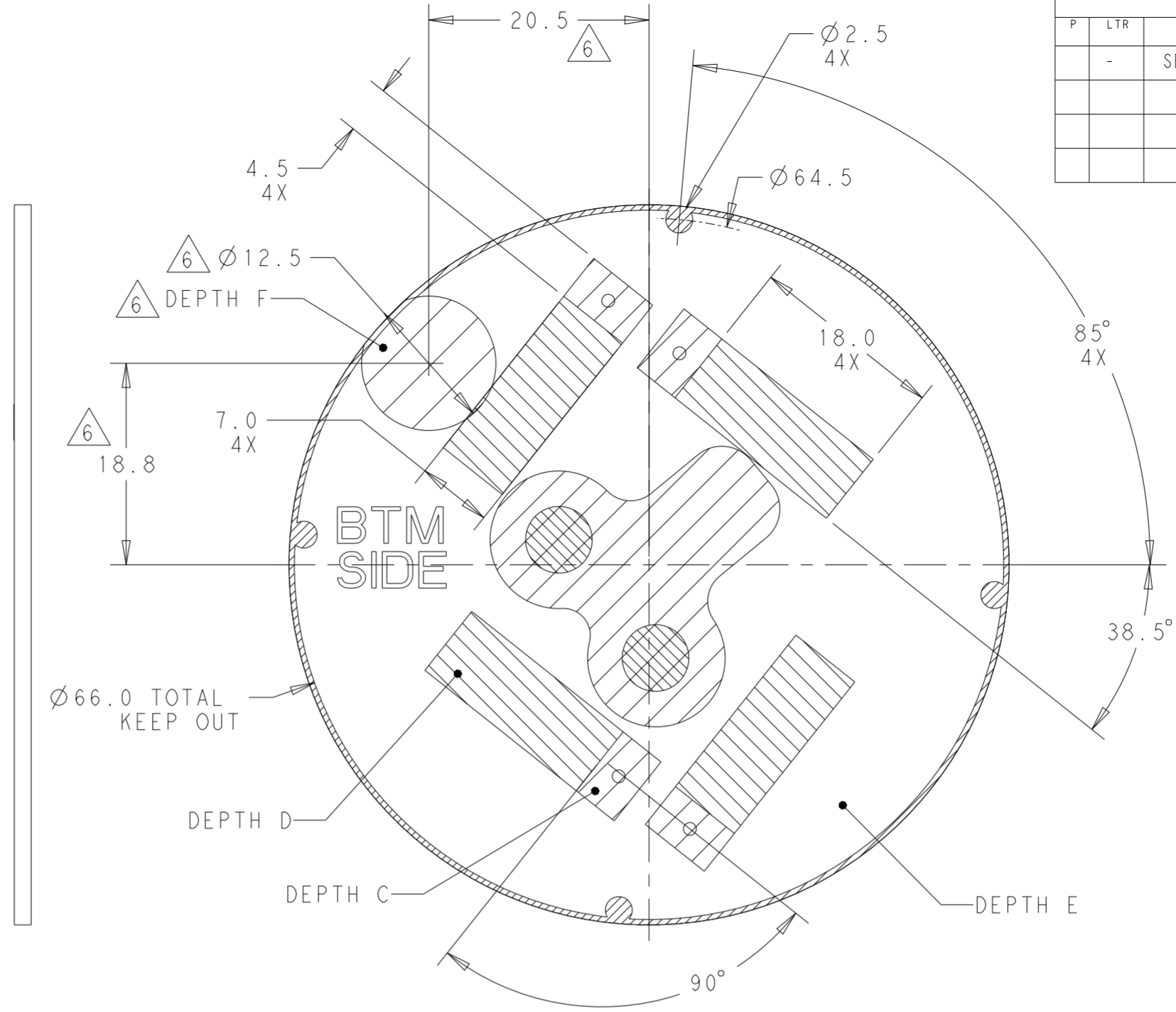
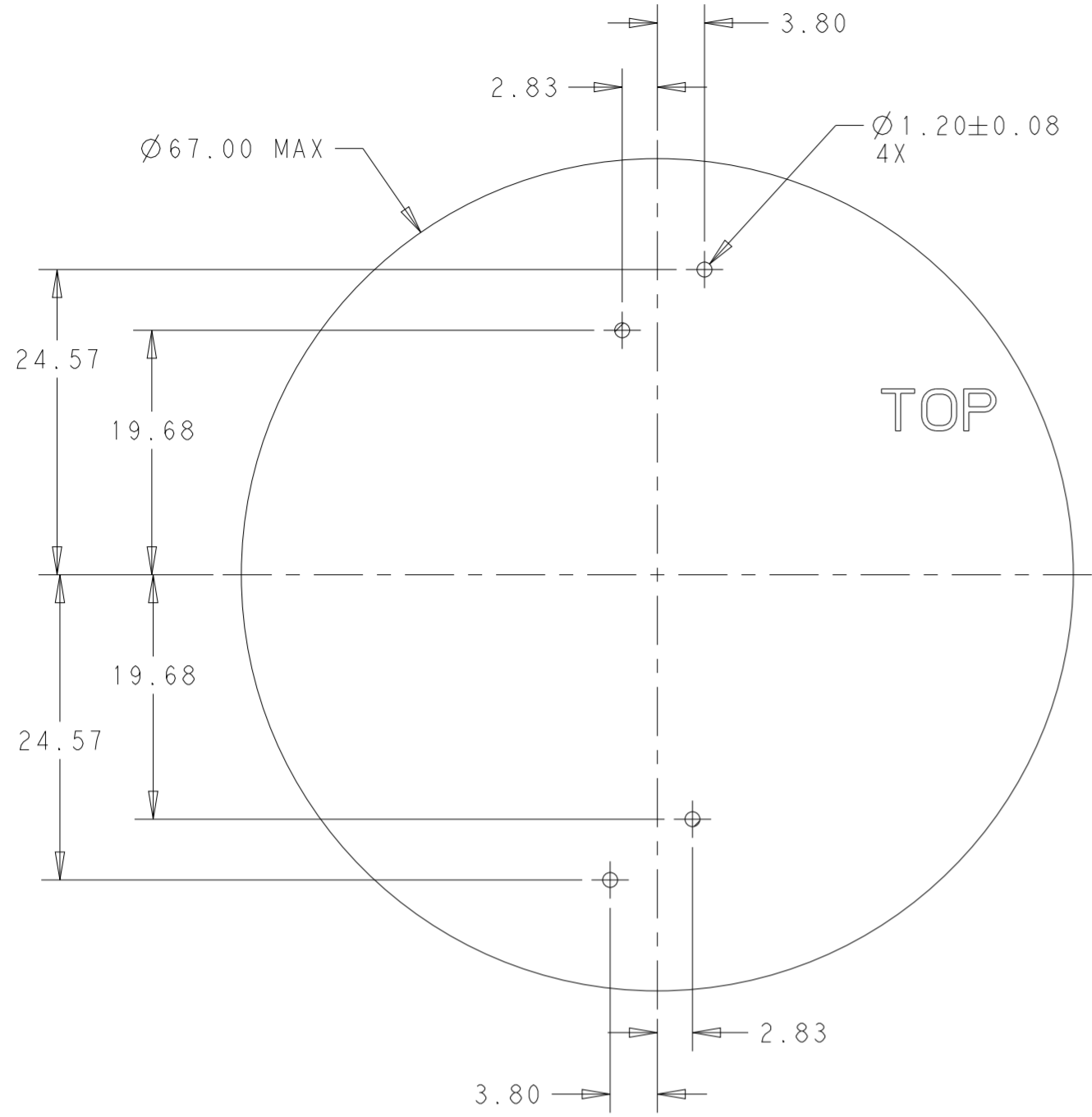

RECOMMENDED PCB

THIS DRAWING IS A CONTROLLED DOCUMENT.		DWN C. DAILY	03OCT2017	TE Connectivity	
DIMENSIONS: mm		CHK MSTOLLER	03OCT2017		
TOLERANCES UNLESS OTHERWISE SPECIFIED:		APVD	-	NAME SHORTING BASE ASSEMBLY, LUMAWISE ENDURANCE N	
0 PLC ±		PRODUCT SPEC	108-32125	SIZE A2	
1 PLC ±0.2		APPLICATION SPEC	114-32159	CAGE CODE	-
2 PLC ±0.25		WEIGHT	-	DRAWING NO	C-2325661
3 PLC ±		CUSTOMER DRAWING	SCALE 1:1	SHEET 2 OF 2	REV A1
4 PLC ±					
ANGLES ±					
FINISH ±					