

Color: ■ black

Dimensions in mm

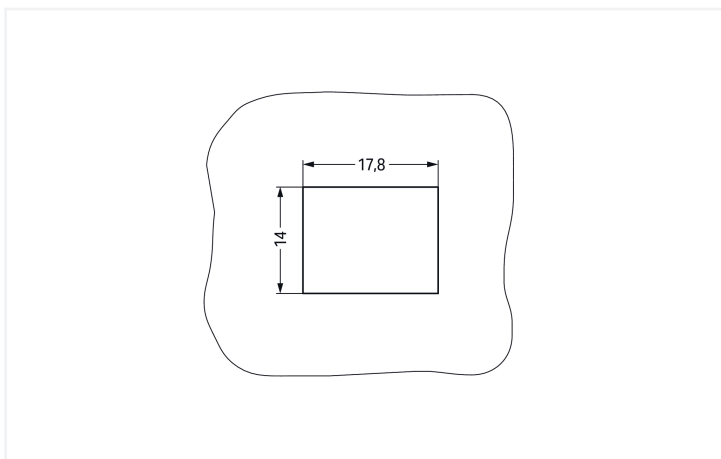

Dimensions in mm

Plate thickness: 0.5 ... 2 mm Cutout tolerance: + 0.1 mm Please note!

Male connector/plug WINSTA® MINI 2-pole

The WINSTA® MINI male connector/plug with protection type IP20 supports rapid, correct installation. The pluggable installation connectors with spring pressure connection technology function without screw connections. They allow flexible, error-free installation in numerous possible uses. The mechanical coding and color coding of the pluggable installation connector ensure error-free installation of the individual components – including protection against mismatching. The WINSTA® MINI pluggable installation connector with A coding in black or white is usually used for general mains applications in power distribution. Particularly where space is tight, our smallest pluggable connection system, WINSTA® MINI, conveniently displays its advantages. It saves space, and, thanks to Push-in CAGE CLAMP® spring pressure connection technology, it additionally can be installed quickly, since the connection is low-maintenance and can be performed without screw connections.

Lower costs through fast commissioning and elimination of service expenses – solutions from WINSTA® MINI

The WINSTA® Pluggable Connection System allows pluggable electrical installation. This saves time, lowers costs, and reduces the need for servicing. Choose quality and durability – with protection against mismatching from WAGO makes the installation of electrical components significantly easier.

- effective protection against mismatching
- easy tool-free operation, a wide range of coding options
- suitable for any application
- exact dimensions
- rapid, structured electrical installation

Notes

General safety information

1. Only to be used by a qualified electrician or by a person electrically instructed for the task (EIP per DIN VDE 0105-100).
2. Do not install while energized or under load.
3. Use only for its intended purpose.
4. Observe applicable national regulations, standards and directives.
5. Observe the technical specifications of the products.
6. Ensure correct polarity assignment.
7. Do not use damaged or contaminated components.
8. Observe conductor types, conductor cross-sections, strip lengths and cable diameters.
9. Insert conductors up to the stop.
10. Use only with locking lever and strain relief.
11. Use original accessories only.

To be sold only with installation instructions!

Note

The snap-in connectors must be relieved of tensile and transverse forces. A surface finish can influence the edge radius of the cutouts. This may affect the snap-in socket fit, so ensure an adequate fit before use. In addition, the punched edge should be on the inside for punched cutouts. The wings of the snap-in connectors must not be mechanically stressed for a long period before use (e.g., due to a pre-locking position).

Electrical data

Ratings per	IEC/EN 60664-1		
Overvoltage category	III	III	II
Pollution degree	3	2	2
Nominal voltage	250 V	-	-
Rated impulse withstand voltage	4 kV	-	-
Rated current	16 A	-	-

Approvals per

UL 1977

Rated voltage	600 V
Rated current	14 A

General information

Note on contact resistance	approx. 1 mΩ of contact resistance approx. 0.25 mΩ contact transition plug/ socket
----------------------------	--

Connection Data

Clamping units	2
Total number of potentials	2

Connection 1

Connection technology	Push-in CAGE CLAMP®
Actuation type	Operating tool Push-in
Nominal cross-section	1.5 mm ² / 16 AWG
Solid conductor	0.25 ... 1.5 mm ² / 22 ... 16 AWG
Solid conductor; push-in termination	0.75 ... 1.5 mm ² / 20 ... 16 AWG
Stranded conductor	0.25 ... 1 mm ² / 22 ... 18 AWG
Fine-stranded conductor	0.25 ... 1.5 mm ² / 22 ... 16 AWG
Fine-stranded conductor; with insulated ferrule	0.25 ... 0.75 mm ² / 22 ... 20 AWG
Fine-stranded conductor; with uninsulated ferrule	0.25 ... 0.75 mm ² / 22 ... 20 AWG
Fine-stranded conductor; with ferrule; push-in termination	0.75 mm ² / 20 AWG
Strip length	9 mm / 0.35 inches
Pole number	2
Conductor entry direction to mating direction	0°

Physical data

Pin spacing	4.4 mm / 0.173 inches
Width	19.8 mm / 0.78 inches
Height	16 mm / 0.63 inches
Depth	39.85 mm / 1.569 inches

Mechanical data

Use	General mains applications
Coding	A
Variable coding	No
Marking	N L
Potential marking	N L
Mating force of a plug-in connection	approx. 20 ... 70 N (depending on pole number)
Retention force of a plug-in connection	Locked: > 80 N
Unmating force of a plug-in connection	Unlocked: approx. 20 ... 70 N (depending on pole number)
Number of mating cycles	200, without resistive load
Housing sheet thickness	0.5 ... 2 mm / 0.02 ... 0.079 inches
Mounting type	Snap-in flange
Protection type	IP20; IP40 when mated
Suitable for through-panel applications	Yes

Plug-in connection

Contact type (pluggable connector)	Male connector/plug
Connector (connection type)	for conductor
Mismating protection	Yes
Note on mismating protection	All <i>WINSTA</i> ® components are 100% protected against mismating when: a.) plugging different numbers of poles b.) plugging while rotated 180 c.) plugging while laterally staggered d.) plugging one pole
Locking lever	Yes
Locking of plug-in connection	Locking lever
Note on locking system	All connectors for mounted installations (snap-in versions for lighting fixtures or devices, all types of PCB and distribution connectors) are factory-equipped with locking levers to ensure plugs and sockets are securely locked. Additional locking levers are only required for flying leads (plug/socket).

Material data

Note (material data)	Information on material specifications can be found here
Color	black
Cover color	gray
Material group	I
Insulation material (main housing)	Polyamide (PA66)
Flammability class per UL94	V0
Clamping spring material	Chrome-nickel spring steel (CrNi)
Contact material	Copper or copper alloy; surface-treated
Contact Plating	Tin
Fire load	0.096 MJ
Weight	4.3 g

Environmental requirements

Processing temperature	-5 ... +40 °C
Continuous operating temperature	-35 ... +85 °C
Note on continuous operating temperature	Insulating parts for temperatures ≤ 105 °C

Commercial data

Product Group	20 (Winsta)
PU (SPU)	50 (50) pcs
Packaging type	Box
Country of origin	PL
GTIN	4045454233457
Customs tariff number	85366990990

Product Classification

UNSPSC	39121402
eCl@ss 10.0	27-44-06-02
eCl@ss 9.0	27-44-06-02
ETIM 9.0	EC002566
ETIM 10.0	EC002566
ECCN	NO US CLASSIFICATION

Environmental Product Compliance

RoHS Compliance Status	Compliant, No Exemption
------------------------	-------------------------

Approvals / Certificates

General approvals



Approval	Standard	Certificate Name
CCA DEKRA Certification B.V.	EN 61535	71-123231
CCA DEKRA Certification B.V.	IEC 61535	NL-85020
cURus Underwriters Laboratories Inc.	UL 1977	E45171

Declarations of conformity and manufacturer's declarations

Approval	Standard	Certificate Name
EU-Declaration of Confor- mity WAGO GmbH & Co. KG	-	-
UK-Declaration of Confor- mity WAGO GmbH & Co. KG	-	-

Approvals for marine applications



Approval	Standard	Certificate Name
ABS American Bureau of Ship- ping	Steel Vessel Rules	24-0095973-PDA
DNV GL Det Norske Veritas, Ger- manischer Lloyd	-	TAE00001Z6
LR Lloyds Register	EN 61535	LR23317167TA
PRS Polski Rejestr Statków	-	TE/1096/880590/23

Downloads

Environmental Product Compliance

Compliance Search			
Environmental Product Compliance 890-712			↓

Documentation

Bid Text			
890-712	19.02.2019	xml 2.92 KB	↓
890-712	30.11.2018	doc 23.00 KB	↓

CAD/CAE-Data

CAD data	
2D/3D Models 890-712	↓

CAE data	
EPLAN Data Portal 890-712	↓
WSCAD Universe 890-712	↓
ZUKEN Portal 890-712	↓

1 Compatible Products

1.1 System counterpart

1.1.1 Cable assembly



Item No.: 891-8992/105-101
pre-assembled connecting cable; Eca; Socket/open-ended; 2-pole; Cod. A; H05VV-F 2 x 1.0 mm²; 1 m; 1,00 mm²; black

Item No.: 891-8992/005-101
pre-assembled interconnecting cable; Eca; Socket/plug; 2-pole; Cod. A; H05VV-F 2 x 1.0 mm²; 1 m; 1,00 mm²; black

1.1.2 Female connector/socket



Item No.: 890-202
Socket; 2-pole; Cod. A; 1,50 mm²; black

Item No.: 890-102
Socket; with strain relief housing; 2-pole; Cod. A; 1,50 mm²; black

Item No.: 890-202/342-000
Socket; with strain relief housing; 2-pole; Cod. A; 1,50 mm²; black

1.2 Optional Accessories

1.2.1 Cover

1.2.1.1 Cover



Item No.: 890-642

Lockout cap; 2-pole; for cutouts; Plastic; black

Item No.: 890-692

Lockout cap; 2-pole; for cutouts; Plastic; white

1.2.2 Tool

1.2.2.1 Operating tool



Item No.: 890-382

Operating tool; 2-way; green

Item No.: 210-719

Operating tool; Blade: 2.5 x 0.4 mm; with a partially insulated shaft

Installation Notes

Conductor termination

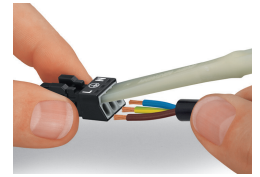
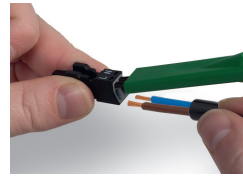
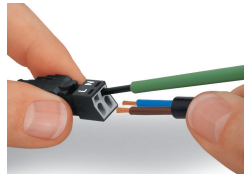

1. Strip length, outer insulation = 30 mm (2-pole), 37 mm (3-pole), 45 mm (4- and 5-pole)
2. Strip length = 9 mm
3. Extended ground conductor = 8 mm

To terminate fine-stranded conductors, open the clamping unit via screwdriver – 2.5 mm blade width – and insert a stripped conductor until it hits the backstop. Terminate solid conductors by simply pushing them in.

To terminate fine-stranded conductors, open clamping units via operating tool (890-382) and insert stripped conductors until they hit backstop. Terminate solid conductors by simply pushing them in.