

Customer Information Sheet

DRAWING No.: M80-461XXXX

SHEET 2 OF 2

IF IN DOUBT - ASK

©

NOT TO SCALE

THIRD ANGLE PROJECTION

ALL DIMENSIONS IN mm

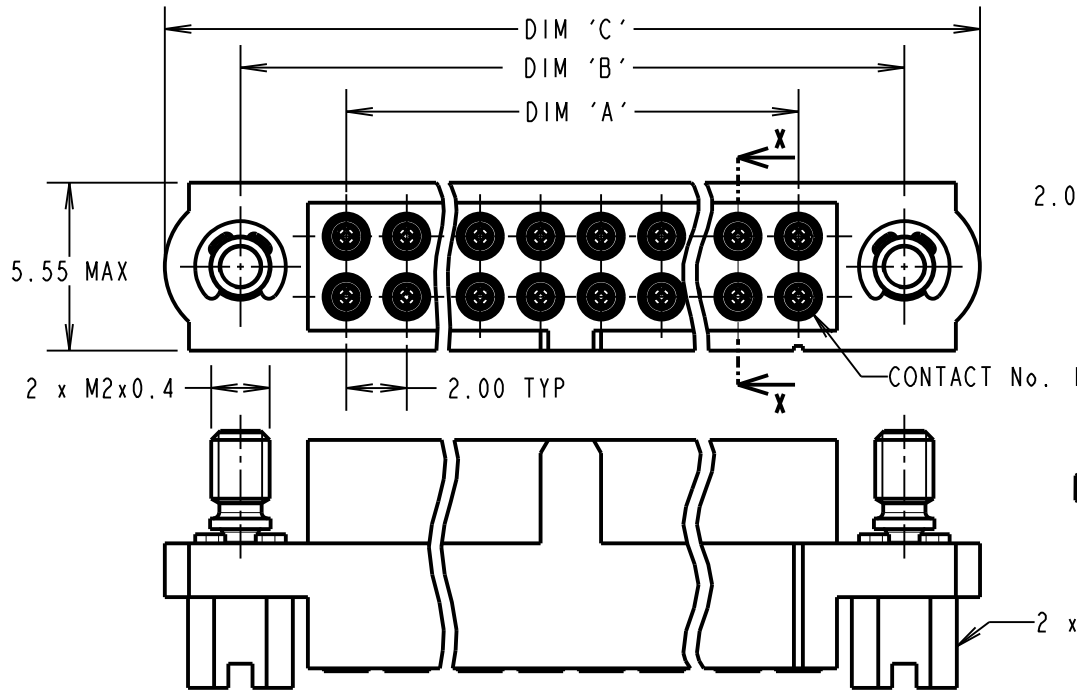

PART SECTION X-X

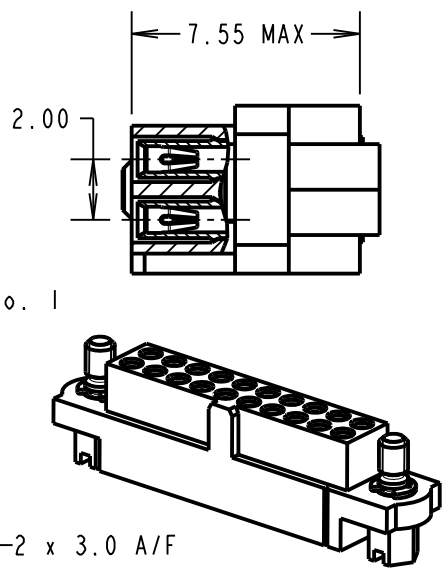

SPECIFICATIONS:

MATERIAL:
 MOULDING = GLASS-FILLED PPS, UL94V-0, BLACK
 CONTACT CLIP = BERYLLIUM COPPER
 CONTACT SHELL = COPPER ALLOY
 JACKSCREW, CIRCLIP = STAINLESS STEEL
FINISH (ALL OVER NICKEL):
 05 = 0.3µ GOLD CLIP, 0.25-0.3µ GOLD SHELL
 42 = 0.3µ GOLD CLIP, 3.5-5.0µ 100% TIN SHELL
ELECTRICAL:
 CURRENT RATING AT 25°C = 3.0A MAX
 CURRENT RATING AT 85°C = 2.2A MAX
 WORKING VOLTAGE = 120V AC/DC
 VOLTAGE PROOF = 360V AC/DC
 CONTACT RESISTANCE = 25 mΩ MAX
 INSULATION RESISTANCE = 100 MΩ MIN
MECHANICAL:
 DURABILITY = 500 OPERATIONS
 INSERTION FORCE (∅0.5mm GAUGE) = 2.8N MAX
 WITHDRAWAL FORCE (∅0.5mm GAUGE) = 0.2N MIN
ENVIRONMENTAL:
 TEMPERATURE RANGE = -55°C TO +125°C
 PACKING: LOOSE
 FOR COMPLETE SPECIFICATION, SEE COMPONENT SPECIFICATION C005XX (LATEST ISSUE)

DIMENSION	CALCULATION
DIM 'A'	TOTAL No. OF CONTACTS - 2
DIM 'B'	TOTAL No. OF CONTACTS + 5
DIM 'C'	TOTAL No. OF CONTACTS + 10

EXAMPLE: CONNECTOR WITH 20 CONTACTS, GOLD ON CONTACT AREA AND 100% TIN ON TAIL, M80-4612042

DIM 'A' = 18.00mm, DIM 'B' = 25.00mm
 DIM 'C' = 30.00mm

ORDER CODE:
M80-461XXXX

TOTAL No. OF CONTACTS —
 04 TO 50
 (EVEN NUMBERS ONLY)

FINISH —
 05 - GOLD CLIP, GOLD SHELL
 42 - GOLD CLIP, 100% TIN SHELL

- NOTES:
- CONNECTORS ARE SUPPLIED WITH CONTACTS LOOSE.
 - FOR EXTRA CONTACTS, USE PART NUMBER M80-0130005 FOR M80-461XX05 AND M80-0130001 FOR M80-461XX42.
 - RECOMMENDED WIRE TYPE = BS 3G 210 TYPE A, PTFE INSULATED 24-28 AWG. MAX INSULATION DIAMETER = ∅1.10mm, STRIP WIRE BY 2.00mm.
 - RECOMMENDED HAND CRIMP TOOL = M22520/2-01 WITH POSITIONER T5747. REFER TO TOOLING INSTRUCTION SHEET IS-01 FOR COMPLETE CRIMPING INSTRUCTIONS.
 - CONTACT INSERTION AND EXTRACTION TOOL = Z80-280. REFER TO TOOLING INSTRUCTION SHEET IS-25 FOR ASSEMBLY INSTRUCTIONS.

SM	4	22.07.11	11389
NAME	ISS.	DATE	C/NOTE
APPROVED: S. MCCULLAGH			
CHECKED: M. G. PLESTED			
DRAWN: W. J. BOURNE			
CUSTOMER REF.:			
ASSEMBLY DRG:			

HARWIN

HARWIN USA TEL: 603 893 5376 FAX: 603 893 5396 mis@harwin.com	HARWIN Europe (UK) TEL: 023 9231 4545 FAX: 023 9231 4590 mis@harwin.co.uk	HARWIN Asia TEL: +65 6 779 4909 FAX: +65 6 779 3868 mis@harwin.com.sg
--	--	--

THIS DRAWING AND ANY INFORMATION OR DESCRIPTIVE MATTER SET OUT HEREON ARE CONFIDENTIAL AND COPYRIGHT PROPERTY OF THE HARWIN GROUP AND MUST NOT BE DISCLOSED, LOANED, COPIED OR USED FOR MANUFACTURING, TENDERING OR FOR ANY OTHER PURPOSE WITHOUT THEIR WRITTEN PERMISSION.

TOLERANCES
 X. = ±1mm
 X.X = ±0.25mm
 X.XX = ±0.10mm
 X.XXX = ±0.01mm
 ANGLES = ±5°
 UNLESS STATED

MATERIAL:
 SEE ABOVE

FINISH: SEE ABOVE

S/AREA: mm²

TITLE: JACKSCREW DATAMATE DIL CRIMP (SMALL BORE) FEMALE ASSEMBLY

DRAWING NUMBER: M80-461XXXX

SHT 2 OF 2