

DATA SHEET

**CURRENT SENSOR - LOW TCR
AUTOMOTIVE GRADE**

PK series

5%, 1%, 0.5%

size 1206/2512

RoHS compliant & Halogen free



SCOPE

This specification describes PK series current sensor – high power and low TCR with lead-free terminations made by metal substrate.

APPLICATIONS

- Consumer goods
- Telecom/servers
- Industrial / Power supply
- Alternative Energy
- Car electronics

FEATURES

- AEC-Q200 qualified
- RoHS compliant
- Pb free without RoHS exemption
- Halogen-free Epoxy
- Environmental hazards reduction
- High component and equipment reliability
- Non-forbidden materials used in products/production
- Low resistances applied to current sensing
- Sulfur resistant

ORDERING INFORMATION - GLOBAL PART NUMBER

Global part numbers are identified by the series, size, tolerance, packing type, temperature coefficient, taping reel and resistance value.

GLOBAL PART NUMBER

PK XXXX X X X XX XXXX L
 (1) (2) (3) (4) (5) (6) (7)

(1) SIZE

1206/2512

(2) TOLERANCE

D = ±0.5%
 F = ±1%
 J = ±5%

(3) PACKAGING TYPE

R = Paper taping reel (PK1206)
 K = Embossed taping reel (PK2512)

(4) TEMPERATURE COEFFICIENT OF RESISTANCE

E = ± 50 ppm/°C
 F = ±100 ppm/°C

(5) TAPING REEL

7T = 7 inch dia. Reel & standard power (2512, 3W)
 57 = 7 inch dia. Reel & standard power (2512, 5W)
 87 = 7 inch dia. Reel & standard power (1206, 2W)

(6) RESISTANCE VALUE

0.5mΩ to 20mΩ

(7) DEFAULT CODE

Letter L is the system default code for ordering only. (Note)

Resistance rule of global part number	
Resistance code rule	Example
0RXXX	0R001 = 0.001Ω
0RXX	0R02 = 0.02Ω
0UX	0U5 = 0.0005Ω
1UX	1U5 = 0.0015Ω

ORDERING EXAMPLE

The ordering code of a PK2512 5W chip resistor, TCR50, value 0.005Ω with ± 1% tolerance, supplied in 7-inch tape reel is: PK2512FKE570R005L

NOTE

1. All our RChip products are RoHS compliant. "LFP" of the internal 2D reel label mentions "Lead-Free Process"

MARKING

PK1206



PK2512

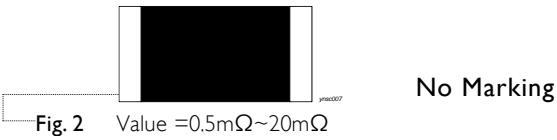

CONSTRUCTION

The resistors are constructed using outstanding TCR level material, which makes YAGEO PK resistors excellent for current sensing application in battery charger circuit & DC-DC converter.

The composition of the resistive material is adjusted to give the approximate required resistance and is covered with a protective coating.

Finally, the three external terminations (Cu / Ni / matte Tin) are added, as shown in Fig. 3.

Outlines

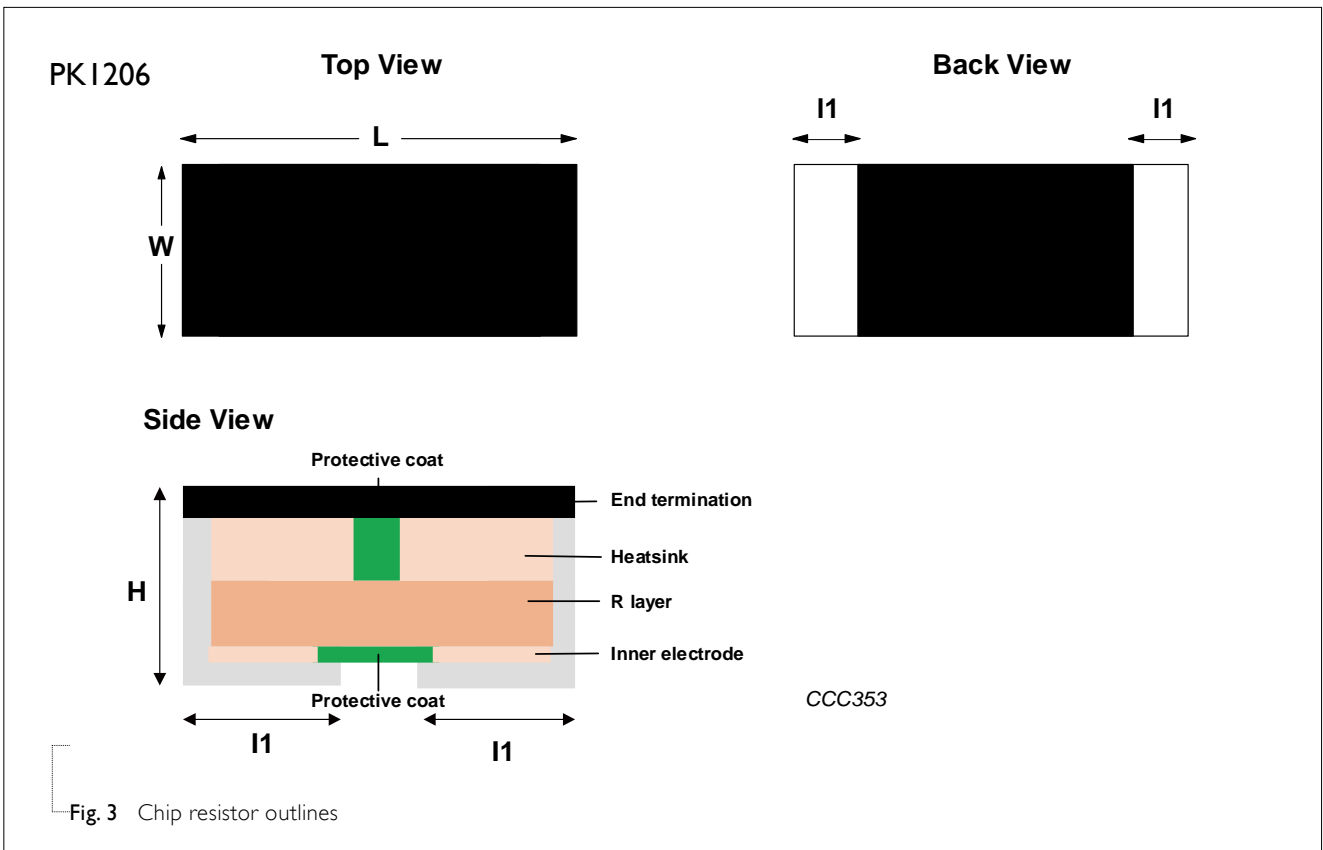

Outlines

PK2512

$$0.5\text{m}\Omega \leq R < 5\text{m}\Omega$$

$$5\text{m}\Omega \leq R \leq 20\text{m}\Omega$$

Top view



Top view

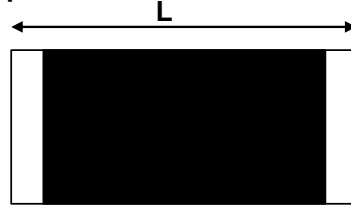

Side view

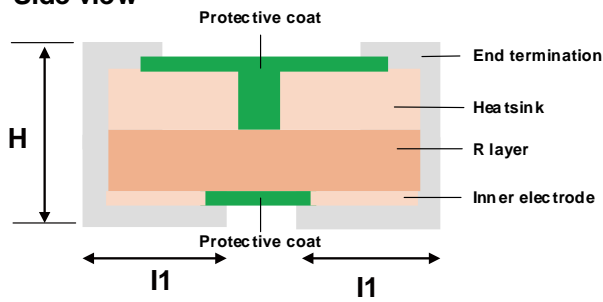

Side view

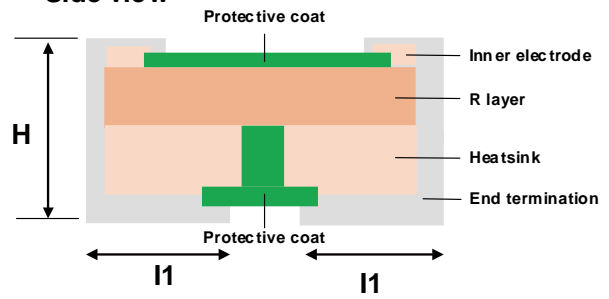

Bottom view

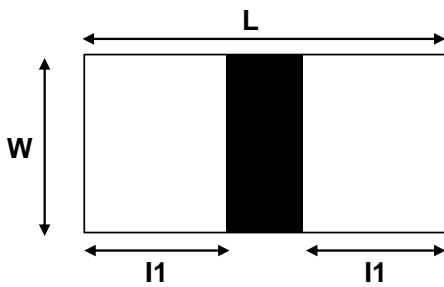

Bottom view

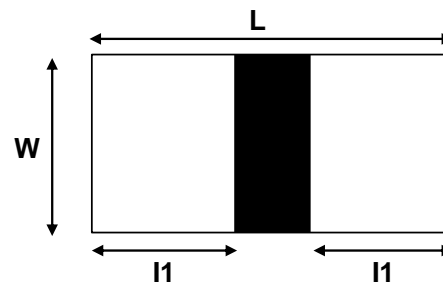

CCC352-2

Fig. 4 Chip resistor outlines

DIMENSION

Table 1 For outlines, please refer to Fig. 2

TYPE	RESISTANCE RANGE	L (mm)	W (mm)	H (mm)	l ₁ (mm)
PK1206	1mΩ	3.20±0.25	1.6±0.25	0.7±0.25	1.00±0.25
	1mΩ < R ≤ 10mΩ	3.20±0.25	1.6±0.25	0.55±0.25	0.5±0.25
	0.5mΩ ≤ R < 1mΩ				2.72±0.25
PK2512	1mΩ ≤ R < 5mΩ	6.35±0.25	3.18±0.25	0.65±0.25	2.5±0.25
	5mΩ ≤ R ≤ 20mΩ	6.35±0.25	3.18±0.25	0.60±0.25	2.72±0.25

Note:

1. For relevant physical dimensions, please refer to construction outlines.
2. Please contact with sales offices, distributors and representatives in your region before ordering.

ELECTRICAL CHARACTERISTICS

Table 2

TYPE	SIZE ⁽¹⁾	POWER RATING ⁽⁴⁾ @70°C			TOLERANCE ⁽²⁾	RESISTANCE RANGE ⁽⁶⁾	TEMPERATURE COEFFICIENT OF RESISTANCE ⁽⁴⁾
		7T	57	87			
PK	1206	-	-	2W	±1% (F)	1mΩ ≤ R < 2mΩ	±100ppm/°C(F)
						2mΩ ≤ R ≤ 10mΩ	±50ppm/°C(E)
	2512	3W	5W	-	±0.5%(D) ±1% (F) ±5% (J)	0.5mΩ ≤ R < 5mΩ	±100ppm/°C(F)
					±1% (F) ±5% (J)	5mΩ ≤ R ≤ 20mΩ	±50ppm/°C(E)

Note: 1. Please contact with sales offices, distributors, and representatives in your region before ordering.

2. Global part number (code 7)
3. Global part number (code 9)
4. Global part number (code 10-11) The shunt resistors' rated power is highly related to the combine heat equivalent from PCB and resistance element. It is recommended to consider design principles such as larger pad surfaces, increasing copper weights, etc., to keep the terminal under its thermal limit.

FUNCTIONAL DESCRIPTION

OPERATING TEMPERATURE RANGE

PK1206, PK2512 Range: -55°C to +170°C

POWER RATING

Standard rated power at 110°C:

For detail power value, please refer to Table 2.

RATED VOLTAGE

The DC or AC (rms) continuous working voltage corresponding to the rated power is determined by the following formula:

$$V = \sqrt{(P \times R)}$$

Where

V = Continuous rated DC or AC (rms) working voltage (V)

P = Rated power (W)

R = Resistance value (Ω)

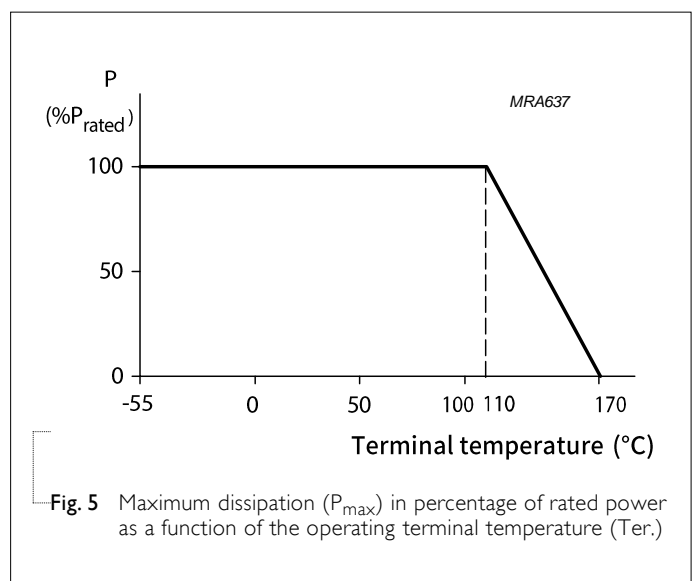

Fig. 5 Maximum dissipation (P_{max}) in percentage of rated power as a function of the operating terminal temperature (T_{er}.)

PACKING STYLE AND PACKAGING QUANTITY

Table 3 Packing style and packaging quantity

PACKING STYLE	REEL DIMENSION	PK1206	PK2512
Paper taping reel (R)	7" (178 mm)	4,000	-
Embossed taping reel (K)	7" (178 mm)	-	4,000

PAPER TAPE

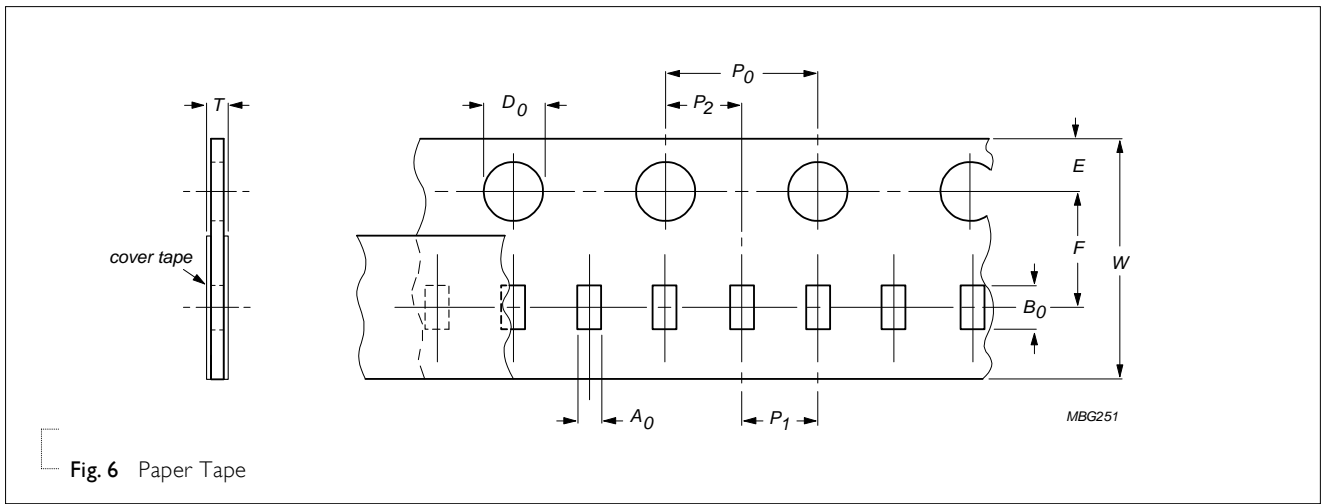

Fig. 6 Paper Tape

EMBOSED TAPE

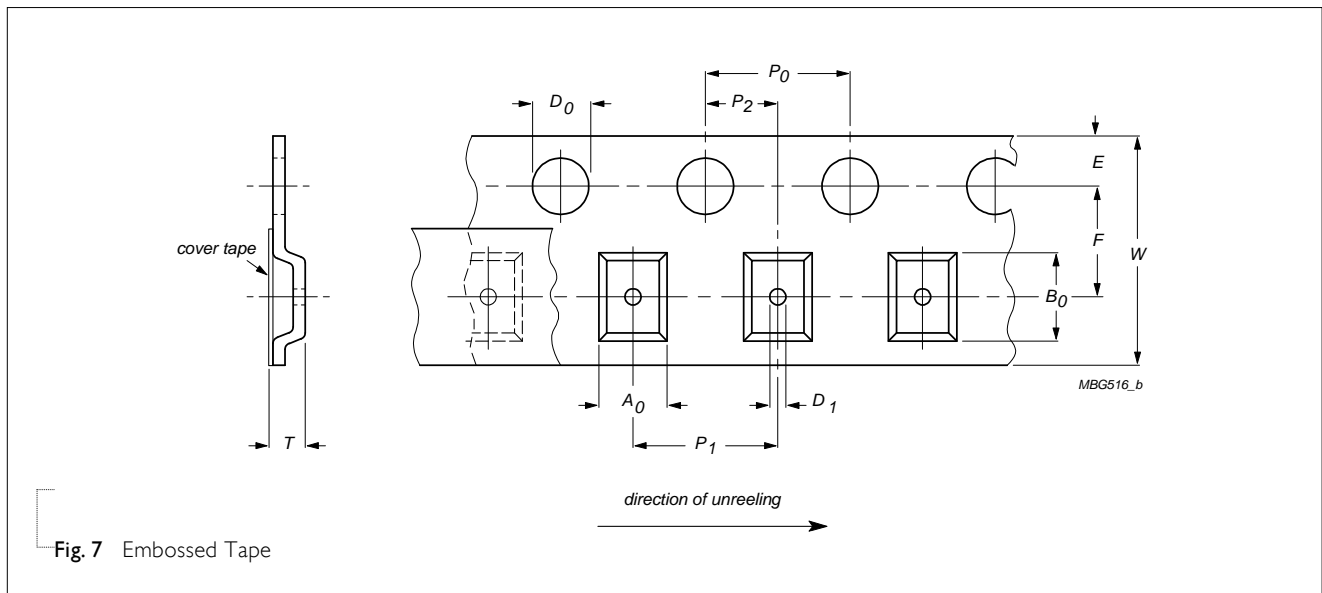

Fig. 7 Embossed Tape

Table 4 Dimensions of embossed tape for relevant chip resistors size

SIZE	SYMBOL											Unit: mm
	A_0	B_0	W	E	F	P_0	P_1	P_2	$\varnothing D_0$	$\varnothing D_1$	T	
PK1206	1.90 ± 0.10	3.50 ± 0.10	8.00 ± 0.30	1.75 ± 0.10	3.50 ± 0.10	4.00 ± 0.10	4.00 ± 0.10	2.00 ± 0.10	1.55 ± 0.05	-	0.85 ± 0.15	
PK2512	3.55 ± 0.15	6.80 ± 0.15	12.00 ± 0.30	1.75 ± 0.10	5.50 ± 0.10	4.00 ± 0.10	4.00 ± 0.10	2.00 ± 0.10	1.55 ± 0.05	1.00 ± 0.15	1.15 ± 0.15	

REEL SPECIFICATION

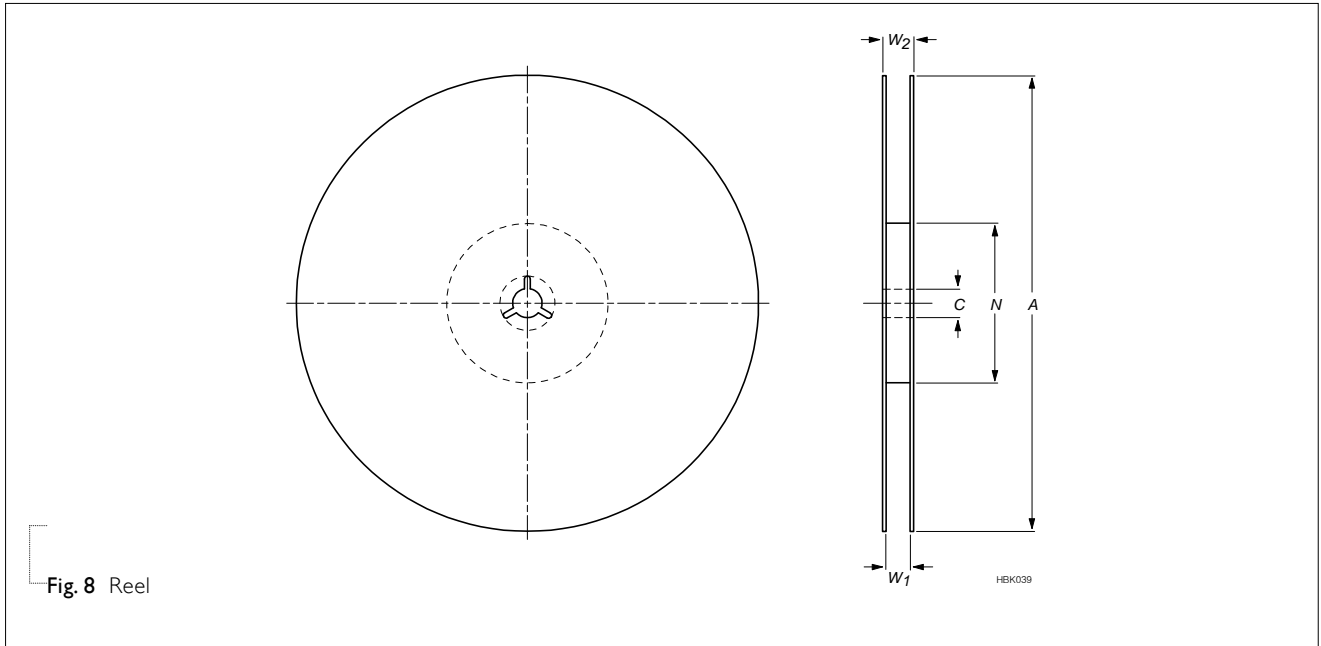
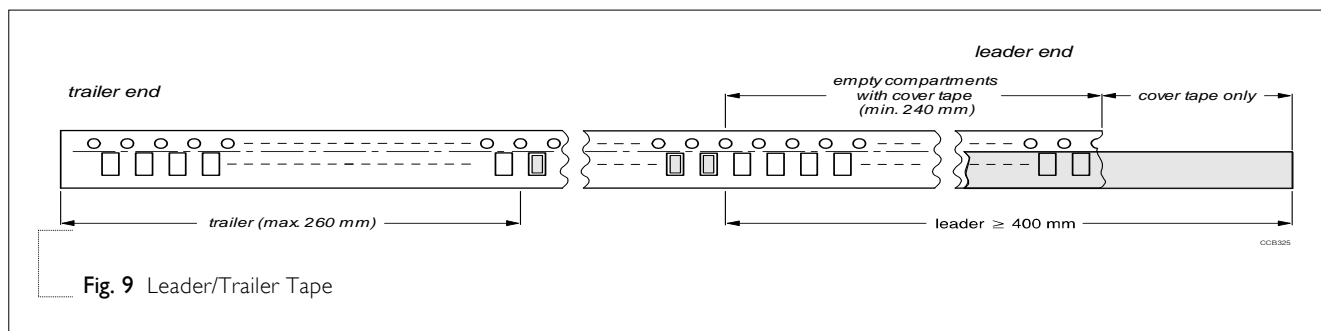

Table 5 Dimensions of reel specification for relevant chip resistors size

SIZE	QUANTITY PER REEL	SYMBOL		Unit: mm			
		12 mm TAPE WIDE	A	N	C	W ₁	W ₂ MAX.
PK1206	4000	7" (Ø178 mm)	178.0±1.0	60.0+1/-0	13.50±0.5	21.0±0.8	9.0±0.5
PK2512	4000	7" (Ø178 mm)	178.0±1.0	60.0+1/-0	13.50±0.5	13.6±0.5	16.5±0.5

LEADER/TRAILER TAPE SPECIFICATION



FOOTPRINT AND SOLDERING PROFILES

For recommended soldering profiles, please refer to data sheet “Chip resistors mounting”.

FOOTPRINT

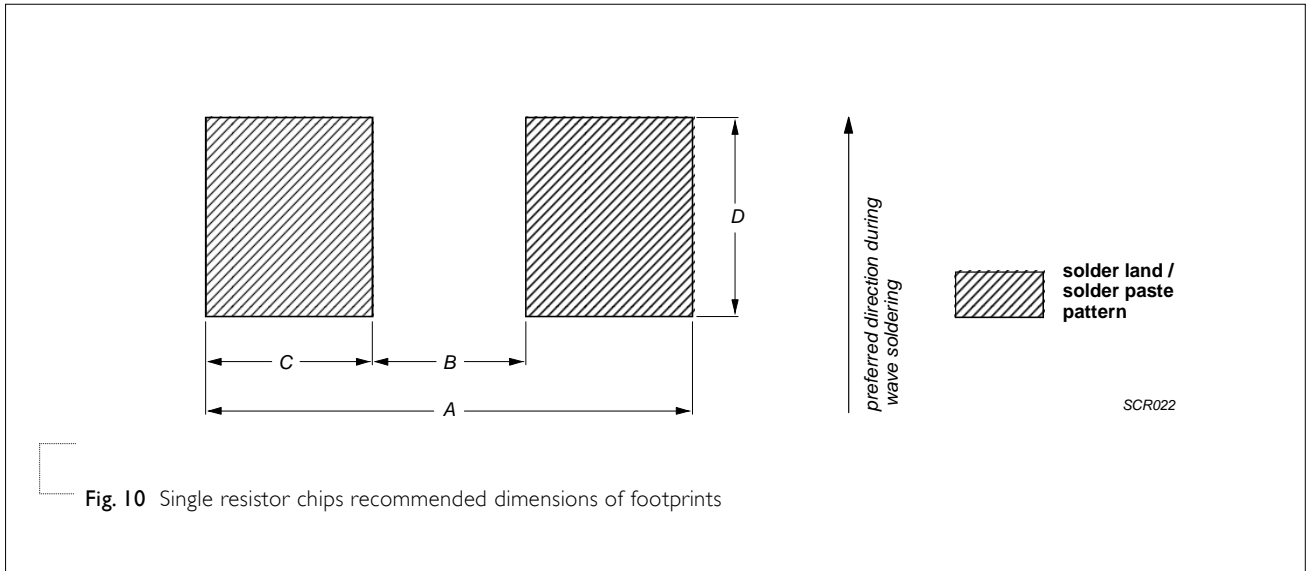

Table 6 Footprint dimensions

SIZE	RESISTANCE RANGE	A	B	C	D	Unit: mm
PK1206	1mΩ	4.20	1.00	1.60	1.84	
	1mΩ < R ≤ 10mΩ	4.20	1.80	1.20	1.84	
PK2512	0.5mΩ ≤ R < 5mΩ	7.37	1.27	3.05	3.68	
	5mΩ ≤ R ≤ 20mΩ	7.46	0.6	3.43	3.68	

TESTS AND REQUIREMENTS

Table 7 Test condition, procedure and requirements

TEST	TEST METHOD	PROCEDURE	REQUIREMENT
Short time overload	IEC 60115-1 8.1	5 times of rated power for 5 seconds at room temperature	±(1%+0.0005 Ω) No visible damage
High Temperature Exposure	MIL-STD-202 method 108 IEC 60068-2-2	1,000 hours at 170 °C unpowered,	±(1%+0.0005 Ω)
Temperature Cycling	JESD22-A104	-55/+155°C, 1000 cycles Dwell time is 15 minutes. Devices mounted Air – Air.	±(1%+0.0005 Ω)
Biased Humidity	MIL-STD-202 Method 103	1,000 hours; 85°C / 85% RH 10% of operating power	±(1%+0.0005 Ω)
Life Endurance	MIL-STD-202 method 108 IEC 60115-1 7.1	1,000 hours at terminal temperature 110 °C applied rated power 1.5 hours on, 0.5 hour off	±(1%+0.0005 Ω)
Resistance to Solvents	MIL-STD-202 Method 215	Immerse in isopropyl alcohol for 5 min with ultrasonic at room temperature	No visible damage
Board Flex / Bending	AEC-Q200-005	Chips mounted on a glass epoxy resin PCB (FR4) Bending: 2 mm Holding time: minimum 60 seconds	±(1%+0.0005 Ω)
Vibration	MIL-STD-202 Method 204	5 g's for 20 min., 12 cycles each of 3 orientations Test from 10-2000 Hz	±(1%+0.0005 Ω)
Resistance to Soldering Heat	MIL-STD-202-method 210	Specimen passed 3 times reflow temperature at 260°C, with solder.	±(0.5%+0.0005Ω) No visible damage
Solderability	J-STD-002	(a) Baking 4 hours @155 °C dry heat, dipping at @245 ±3 °C for 5±0.5 second. (b) Baking 4 hours @155 °C dry heat, dipping at @260 ±3 °C for 30±0.5 second.	Good tinning (95% covered); no visual damage.
Temperature Coefficient of Resistance (T.C.R.)	MIL-STD-202 Method 304	1206/2512 : at+25/150 °C Formula: $T.C.R = \frac{R_2 - R_1}{R_1(t_2 - t_1)} \times 10^6(\text{ppm}/^\circ\text{C})$ Where t ₁ =+25°C or specified room temperature PK1206 at t ₂ =125 °C PK2512 at t ₂ =150 °C test temperature R ₁ =resistance at reference temperature in ohms R ₂ =resistance at test temperature in ohms	Refer to table 2

REVISION HISTORY

REVISION	DATE	CHANGE NOTIFICATION	DESCRIPTION
Version 2	Oct. 30, 2025	-	- Extend 2512 resistor value
Version 1	Sep. 02, 2025	-	- Add size 1206 resistance value
Version 0	Feb. 24, 2025	-	- First issue of this specification

LEGAL DISCLAIMER

YAGEO, its distributors and agents (collectively, "YAGEO"), hereby disclaims any and all liabilities for any errors, inaccuracies or incompleteness contained in any product related information, including but not limited to product specifications, datasheets, pictures and/or graphics. YAGEO may make changes, modifications and/or improvements to product related information at any time and without notice.

YAGEO makes no representation, warranty, and/or guarantee about the fitness of its products for any particular purpose or the continuing production of any of its products. To the maximum extent permitted by law, YAGEO disclaims (i) any and all liability arising out of the application or use of any YAGEO product, (ii) any and all liability, including without limitation special, consequential or incidental damages, and (iii) any and all implied warranties, including warranties of fitness for a particular purpose, non-infringement and merchantability.

YAGEO products are designed for general purpose applications under normal operation and usage conditions. Please contact YAGEO for the applications listed below which require especially high reliability for the prevention of defects which might directly cause damage to the third party's life, body or property: Aerospace equipment (artificial satellite, rocket, etc.), Atomic energy-related equipment, Aviation equipment, Disaster prevention equipment, crime prevention equipment, Electric heating apparatus, burning equipment, Highly public information network equipment, data-processing equipment, Medical devices, Military equipment, Power generation control equipment, Safety equipment, Traffic signal equipment, Transportation equipment and Undersea equipment, or for any other application or use in which the failure of YAGEO products could result in personal injury or death, or serious property damage. Particularly **YAGEO Corporation and its affiliates do not recommend the use of commercial or automotive grade products for high reliability applications or manned space flight.**

Information provided here is intended to indicate product specifications only. YAGEO reserves all the rights for revising this content without further notification, as long as products are unchanged. Any product change will be announced by PCN.