

Data Sheet | Item Number: 216-101

Ferrule; Sleeve for 0.5 mm² / AWG 22; uninsulated; electro-tin plated; silver-colored

<https://www.wago.com/216-101>

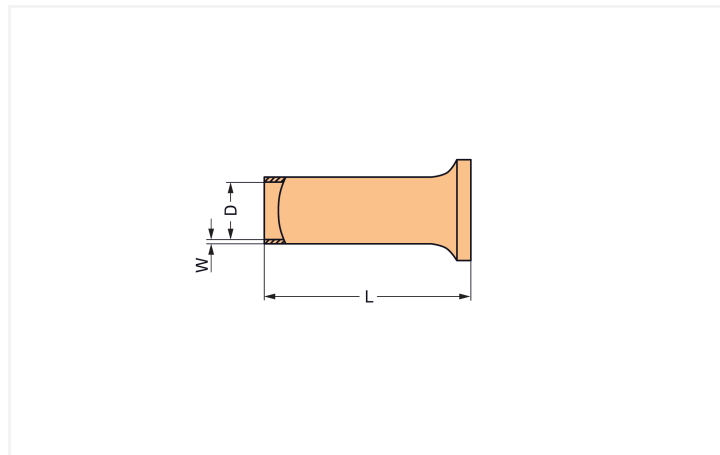

Color: ■ silver-colored

Dimensions in mm

Connection Data

Metric cross-section of the ferrule	0.5 mm ²
Strip length	8 ... 9 mm / 0.31 ... 0.35 inches
Cross-section (AWG) of ferrule	20 AWG

Physical data

Total length	8 mm
Wall thickness of crimp sleeve	0.15 mm
Diameter crimp sleeve inside	1 mm

Mechanical data

Plastic collar	No
----------------	----

Material data

Color	silver-colored
Fire load	0 MJ
Weight	0 g

Commercial data

Product Group	2 (Terminal Block Accessories)
PU (SPU)	5000 (1000) pcs
Packaging type	Box
Country of origin	DE
GTIN	4017332277617
Customs tariff number	85369010000

Product Classification

UNSPSC	39121405
eCl@ss 10.0	27-40-02-01
eCl@ss 9.0	27-40-02-01
ETIM 9.0	EC000005
ETIM 10.0	EC000005
ECCN	NO US CLASSIFICATION

Environmental Product Compliance

RoHS Compliance Status	Compliant, No Exemption
------------------------	-------------------------

Downloads

Environmental Product Compliance

Compliance Search	
Environmental Product Compliance 216-101	↓

Documentation

Bid Text			
216-101	11.09.2017	doc 24.00 KB	↓
216-101	19.02.2019	xml 2.77 KB	↓

Installation Notes

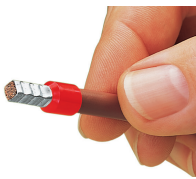

A perfect gas-tight crimp – both electrically and mechanically reliable

Subject to changes. Please also observe the further product documentation!

Current addresses can be found at: www.wago.com