

# Ultra Compact Chip Antenna Data Guide

**Wireless made simple<sup>®</sup>**

# Table of Contents

- 1 Description
- 1 Features
- 2 Applications
- 2 Ordering Information
- 2 Electrical Specifications
- 3 Footprints
- 3 Pin Configuration
- 4 Theory of Operation
- 4 Layout Considerations
- 5 Microstrip Details
- 6 Assembly Considerations
- 8 Test Boards
- 9 VSWR Graphs
- 10 Tape Dimensions
- 12 Reel Dimensions
- 13 Mismatch Conversion Table

## Ultra Compact Chip Antenna

# Data Guide

### Description

The exciting ANT-\*\*\*-CHP family is among the world's smallest high-performance chip antennas. They are ideal for embedding in wireless products including Bluetooth, 802.11, Home RF, ZigBee and other popular standards. These tiny antennas use advanced Low Temperature Co-fired Ceramic (LTCC) technology and proprietary elements to achieve superior size and performance characteristics. The entire family is compatible with hand and reflow-assembly. Excellent electrical specifications, stability, and outstanding cost-effectiveness make CHP Series antennas the logical choice for a wide variety of applications.

### Features

- Incredibly compact SMD package
- Superior LTCC technology
- 50Ω characteristic impedance
- Low loss
- Wide bandwidth
- Favorable linear polarization
- > Unity gain
- No external matching required
- Highly stable over temperature & time
- Hand and reflow-assembly compatible
- RoHS compliant
- Cost-effective

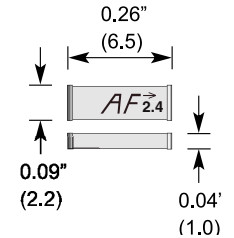

Figure 1: 2.4GHz Dimensions

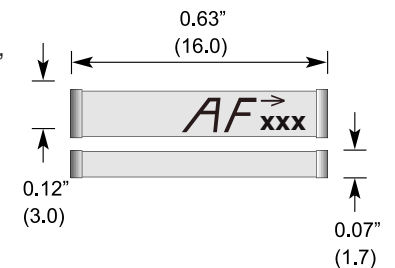

Figure 2: 868MHz and 916MHz Dimensions

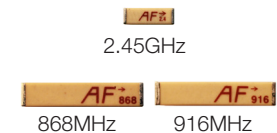

Figure 3: Actual Sizes

## Applications

- Bluetooth
- 802.11
- ZigBee
- Wireless PCMCIA cards
- Telemetry
- Data collection
- Industrial process monitoring
- Compact wireless products
- External antenna elimination

## Ordering Information

| Ordering Information |                      |
|----------------------|----------------------|
| Part Number          | Description          |
| ANT-868-CHP-x        | 868Mhz Chip Antenna  |
| ANT-916-CHP-x        | 916MHz Chip Antenna  |
| ANT-2.45-CHP-x       | 2.45GHz Chip Antenna |

x = "T" for tape/reel, "B" for bulk

All parts are RoHS compliant.  
Standard reel is 3,000pcs. (868/916MHz), 1,500pcs. (2.45GHz)  
Quantities less than reel size are supplied in bulk.

Figure 4: Ordering Information

## Electrical Specifications

| Specifications         |                          |                           |                           |
|------------------------|--------------------------|---------------------------|---------------------------|
| Parameter              | 2.45GHz                  | 868MHz                    | 916MHz                    |
| Physical               |                          |                           |                           |
| Dimensions (mm)        | 6.5(L) x 2.2(W) x 1.0(H) | 16.0(L) x 3.0(W) x 1.7(H) | 16.0(L) x 3.0(W) x 1.7(H) |
| Operating/Storage Temp | -40 to +85°C             | -40 to +85°C              | -40 to +85°C              |
| Construction           | LTCC                     | LTCC                      | LTCC                      |
| Electrical             |                          |                           |                           |
| Center Frequency       | 2.45GHz                  | 868MHz                    | 916MHz                    |
| Bandwidth              | 180MHz                   | 10MHz                     | 10MHz                     |
| Wavelength             | ¼-wave                   | ¼-wave                    | ¼-wave                    |
| Pattern                | Omni-directional         | Omni-direction            | Omni-directional          |
| Polarization           | Linear                   | Linear                    | Linear                    |
| VSWR                   | ≤2.0 (Max.)              | ≤2.0 (Max.)               | ≤2.0 (Max.)               |
| Maximum Gain           | +0.5dBi                  | +0.5dBi                   | +0.5dBi                   |
| Impedance              | 50Ω                      | 50Ω                       | 50Ω                       |
| Power Handling         | 3W (Max.)                | 3W (Max.)                 | 3W (Max.)                 |

Figure 5: Ordering Information

## Footprints

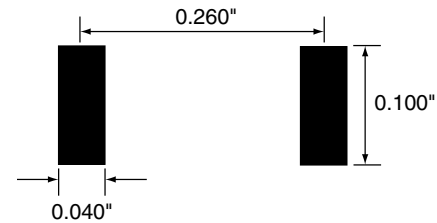

Figure 6: 2.4GHz Footprint

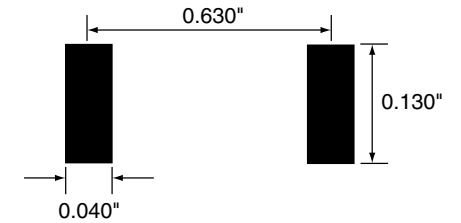

Figure 7: 868MHz and 916MHz Footprint

## Pin Configuration

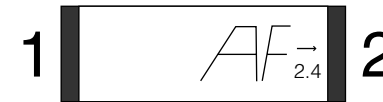

Figure 8: Pin Configuration

| Pin Descriptions |   |
|------------------|---|
| Pin Number       | Description   |
| 1                | Feed Termination<br>This pin connects to the transmitter or receiver.   |
| 2                | Solder Termination<br>This pin is soldered down for physical support only. There is no electrical connection. |

Figure 9: Pin Configurations

## Theory of Operation

The CHP Series antennas utilize Low Temperature Cofired Ceramic (LTCC) technology to embed the antenna element into a ceramic substrate. Advances in this technology have resulted in materials that are extremely stable over time and temperature, producing an antenna that is highly reliable across a wide range of applications. The high-frequency characteristics of this technology enable exceptional performance in a very small package. The construction techniques for LTCC devices lends itself well to favorable pricing in high volume.

## Layout Considerations

Proper layout is vital to ensure correct operation and optimum performance. Improper placement of planes, traces, or system components will result in nulls or complete de-tuning. Ideally, the antenna will be mounted on the board in such a way as to allow an unobstructed field of view. The area underneath the antenna must be free of components, traces, and planes. Components may be placed to the rear of the antenna in the ground plane counterpoise area. The feed trace from the RF stage to the antenna must be a microstrip trace or coax transmission line and should be kept as short as practical.

The layout of our reference jigs is illustrated on the following pages. While they demonstrate various aspects of a layout, it is not necessary to replicate them exactly. While your board size and layout may differ, it is important to recognize that the counterpoise plays an important role in resonance and stability since it acts, in essence, as part of the antenna. After your own layout is complete, the performance of the antenna in your specific product should be carefully checked using tools like a network analyzer. In some cases, the size of the product's PCB, proximity of the case, or other factors may make a custom version of the antenna necessary. Contact Linx for more information.

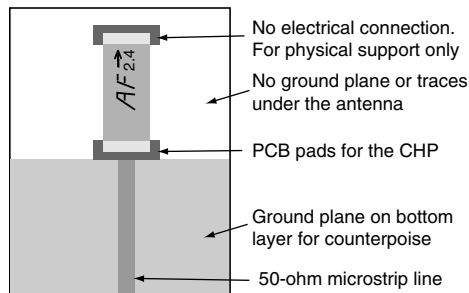
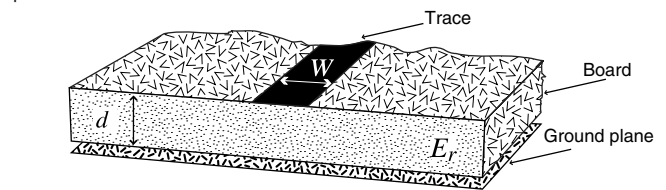

Figure 10: Layout

## Microstrip Details

A transmission line is a medium whereby RF energy is transferred from one place to another with minimal loss. This is a critical factor, especially in high-frequency products like Linx RF modules, because the trace leading to the module's antenna can effectively contribute to the length of the antenna, changing its resonant bandwidth. In order to minimize loss and detuning, some form of transmission line between the antenna and the module should be used unless the antenna can be placed very close (<1/8in.) to the module. One common form of transmission line is a coax cable and another is the microstrip. This term refers to a PCB trace running over a ground plane that is designed to serve as a transmission line between the module and the antenna. The width is based on the desired characteristic impedance of the line, the thickness of the PCB and the dielectric constant of the board material. For standard 0.062in thick FR-4 board material, the trace width would be 111 mils. The correct trace width can be calculated for other widths and materials using the information in Figure 11 and examples are provided in Figure 12. Software for calculating microstrip lines is also available on the Linx website.



$$E_e = \frac{E_r + 1}{2} + \frac{E_r - 1}{2} \cdot \frac{1}{\sqrt{1 + 12d/W}}$$

$$Z_0 = \begin{cases} \frac{60}{\sqrt{E_e}} \cdot \ln\left(\frac{8d}{W} + \frac{W}{4d}\right) & \text{For } \frac{W}{d} \leq 1 \\ \frac{120\pi}{\sqrt{E_e} \cdot \left(\frac{W}{d} + 1.393 + 0.667 \cdot \ln\left(\frac{W}{d} + 1.444\right)\right)} & \text{For } \frac{W}{d} \geq 1 \end{cases}$$

$E_r$  = Dielectric constant of PCB material

Figure 11: Microstrip Formulas

| Example Microstrip Calculations |                              |                               |                                       |
|---------------------------------|------------------------------|-------------------------------|---------------------------------------|
| Dielectric Constant             | Width / Height Ratio (W / d) | Effective Dielectric Constant | Characteristic Impedance ( $\Omega$ ) |
| 4.80                            | 1.8                          | 3.59                          | 50.0                                  |
| 4.00                            | 2.0                          | 3.07                          | 51.0                                  |
| 2.55                            | 3.0                          | 2.12                          | 48.8                                  |

Figure 12: Example Microstrip Calculations

## Assembly Considerations

The antenna is RoHS Compliant and designed to support hand or automated assembly. To avoid damage to the part, the reflow solder guidelines found below should be carefully followed. The antenna is single ended meaning that one pad is electrically connected while the other is for mechanical support only. The antenna terminals are not interchangeable so the polarity indicated in the Pin Configuration section must be observed during assembly.

## Hand Soldering

This antenna is designed for high-volume automated assembly, however, it may be successfully attached by hand assembly techniques. A hand-solder temperature of 225°C or lower should be used. Do not exceed a 10sec. heating time.

## Reflow Temperature Profile

The single most critical stage in the automated assembly process is the reflow process. The reflow profile below should be closely followed since excessive temperatures or transport times during reflow will irreparably damage the antennas. Assembly personnel will need to pay careful attention to the oven's profile to ensure that it meets the requirements necessary to successfully reflow all components while still meeting the limits mandated by the antennas themselves.

## Reflow Soldering Profile

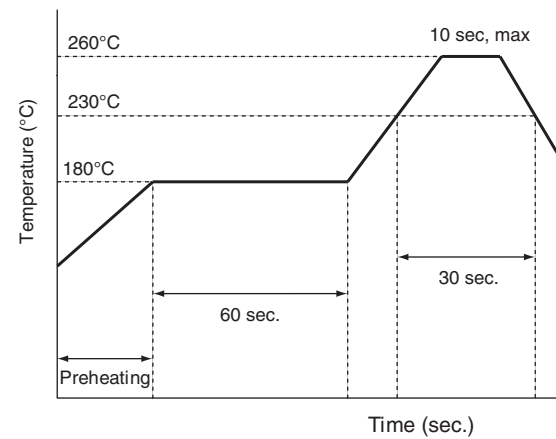

Figure 13: Reflow Soldering Profile

**Warning:** Pay attention to the absolute maximum solder times.

### Absolute Maximum Solder Times

Hand Solder Temperature: TX +225°C for 10 seconds

Hand Solder Temperature: RX +225°C for 10 seconds

Recommended Solder Melting Point: +180°C

Reflow Oven: +225°C max (see Figure 13)

Figure 14: Absolute Maximum Solder Times

## Test Boards

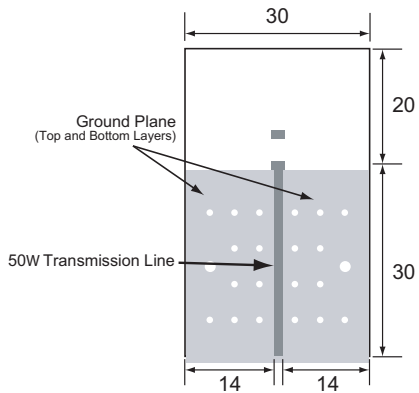

Figure 15: 2.4GHz Test Board

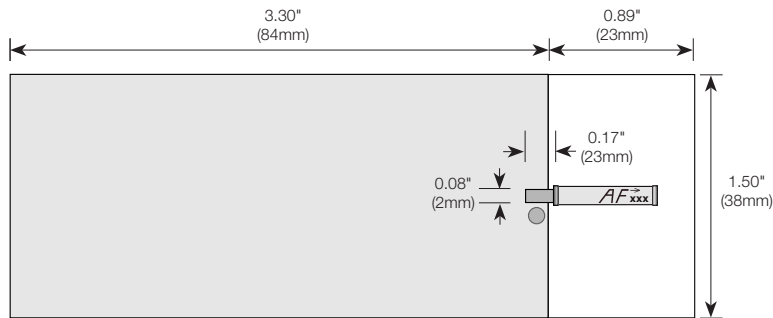

Figure 16: 868MHz and 916MHz Test Board

## VSWR Graphs

### What is VSWR?

The Voltage Standing Wave Ratio (VSWR) is a measurement of how well an antenna is matched to a source impedance, typically 50-ohms. It is calculated by measuring the voltage wave that is headed toward the load versus the voltage wave that is reflected back from the load. A perfect match will have a VSWR of 1:1. The higher the first number, the worse the match, and the more inefficient the system. Since a perfect match cannot ever be obtained, some benchmark for performance needs to be set. In the case of antenna VSWR, this is usually 2:1. At this point, 88.9% of the energy sent to the antenna by the transmitter is radiated into free space and 11.1% is either reflected back into the source or lost as heat on the structure of the antenna. In the other direction, 88.9% of the energy recovered by the antenna is transferred into the receiver. As a side note, since the “:1” is always implied, many data sheets will remove it and just display the first number.

### How to Read a VSWR Graph

VSWR is usually displayed graphically versus frequency. The lowest point on the graph is the antenna's operational center frequency. In most cases, this will be different than the designed center frequency due to fabrication tolerances. The VSWR at that point denotes how close to 50-ohms the antenna gets. Linx specifies the recommended bandwidth as the range where the typical antenna VSWR is less than 2:1.

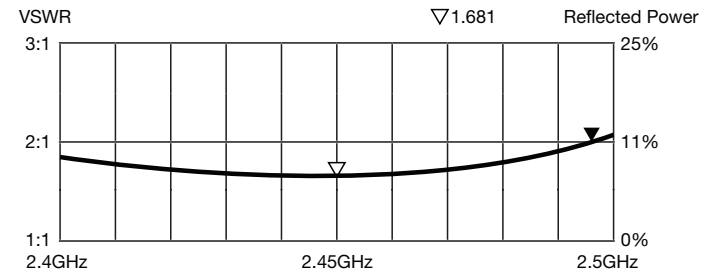

Figure 17: 2.4GHz Typical VSWR

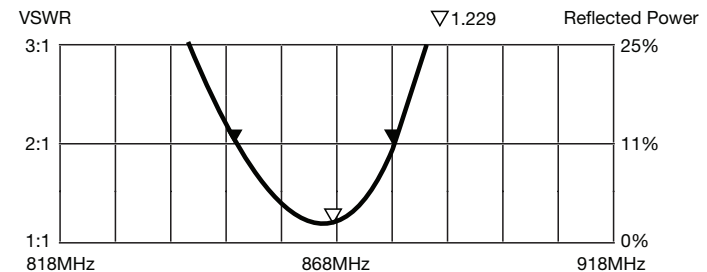

Figure 18: 868MHz and 916MHz Typical VSWR

## Tape Dimensions

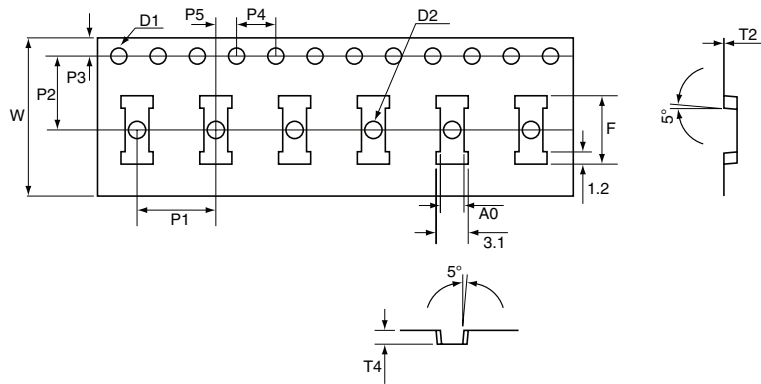

Figure 19: 2.4GHz Tape Dimensions

| 2.4GHz Tape Dimensions |           |                |      |
|------------------------|-----------|----------------|------|
| Symbol                 | Dimension | Tolerance      | Unit |
| A0                     | 2.30      | ±0.10          | mm   |
| D1                     | 1.50      | ±0.10<br>-0.00 | mm   |
| D2                     | 1.50      | ±0.25<br>-0.00 | mm   |
| F                      | 6.60      | ±0.10          | mm   |
| P1                     | 8.00      | ±0.10          | mm   |
| P2                     | 7.50      | ±0.10          | mm   |
| P3                     | 1.75      | ±0.10          | mm   |
| P4                     | 4.00      | ±0.10          | mm   |
| P5                     | 2.00      | ±0.10          | mm   |
| T2                     | 0.30      | ±0.05          | mm   |
| T4                     | 1.30      | ±0.10          | mm   |
| W                      | 16.00     | ±0.10          | mm   |

Figure 20: 2.4GHz Tape Dimensions Table

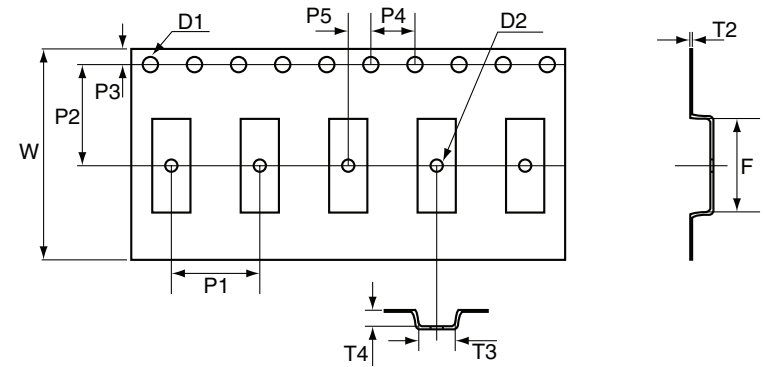

Figure 21: 868MHz and 916MHz Tape Dimensions

| 868MHz and 916MHz Tape Dimensions |           |           |      |
|-----------------------------------|-----------|-----------|------|
| Symbol                            | Dimension | Tolerance | Unit |
| D1                                | 1.50      | ±0.10     | mm   |
| D2                                | 1.50      | ±0.10     | mm   |
| F                                 | 10.6      | ±0.10     | mm   |
| P1                                | 8.00      | ±0.10     | mm   |
| P2                                | 11.50     | ±0.10     | mm   |
| P3                                | 1.75      | ±0.10     | mm   |
| P4                                | 4.00      | ±0.10     | mm   |
| P5                                | 2.00      | ±0.10     | mm   |
| T2                                | 0.30      | ±0.05     | mm   |
| T3                                | 3.30      | ±0.10     | mm   |
| T4                                | 1.90      | ±0.10     | mm   |
| W                                 | 24.00     | ±0.30     | mm   |

Figure 21: 868MHz and 916MHz Tape Dimensions Table

## Reel Dimensions

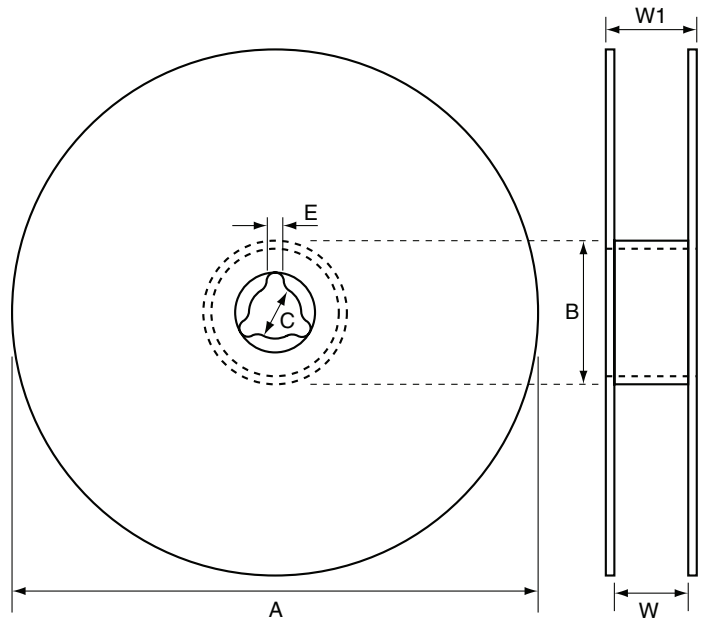

Figure 22: Reel Dimensions

| Reel Dimensions |            |         |      |
|-----------------|------------|---------|------|
| Symbol          | 868/916MHz | 2.45GHz | Unit |
| QTY per reel    | 3,000      | 1,500   | pcs  |
| Tape width      | 24         | 16      | mm   |
| A               | 330±1      | 180±1   | mm   |
| B               | 100±0.5    | 62±0.5  | mm   |
| C               | 13±0.5     | 13±0.2  | mm   |
| E               | 2.2±0.5    | 2.2±0.5 | mm   |
| W               | 24±0.5     | 16±0.5  | mm   |
| W1              | 28.9±0.2   | 20±0.2  | mm   |

Figure 23: Reel Dimensions Table

## Mismatch Conversion Table

| Mismatch Conversion Table |                     |                       |                     |
|---------------------------|---------------------|-----------------------|---------------------|
| VSWR                      | Insertion Loss (dB) | Power Transmitted (%) | Power Reflected (%) |
| 17.391                    | -6.87               | 20.57%                | 79.43%              |
| 11.610                    | -5.35               | 29.21%                | 70.79%              |
| 8.724                     | -4.33               | 36.90%                | 63.10%              |
| 6.997                     | -3.59               | 43.77%                | 56.23%              |
| 5.848                     | -3.02               | 49.88%                | 50.12%              |
| 5.030                     | -2.57               | 55.33%                | 44.67%              |
| 4.419                     | -2.20               | 60.19%                | 39.81%              |
| 3.946                     | -1.90               | 64.52%                | 35.48%              |
| 3.570                     | -1.65               | 68.38%                | 31.62%              |
| 3.010                     | -1.26               | 74.88%                | 25.12%              |
| 2.615                     | -0.97               | 80.05%                | 19.95%              |
| 2.323                     | -0.75               | 84.15%                | 15.85%              |
| 2.100                     | -0.58               | 87.41%                | 12.59%              |
| 1.925                     | -0.46               | 90.00%                | 10.00%              |
| 1.433                     | -0.14               | 96.84%                | 3.15%               |
| 1.222                     | -0.04               | 99.00%                | 1.00%               |
| 1.119                     | -0.01               | 99.68%                | 0.32%               |
| 1.065                     | 0.00                | 99.90%                | 0.10%               |
| 1.034                     | 0.00                | 99.97%                | 0.03%               |
| 1.020                     | 0.00                | 99.99%                | 0.01%               |

Figure 24: Mismatch Conversion Table

(This page is intentionally blank.)

(This page is intentionally blank.)

---

## TE TECHNICAL SUPPORT CENTER

|                   |                       |
|-------------------|-----------------------|
| USA:              | +1 (800) 522-6752     |
| Canada:           | +1 (905) 475-6222     |
| Mexico:           | +52 (0) 55-1106-0800  |
| Latin/S. America: | +54 (0) 11-4733-2200  |
| Germany:          | +49 (0) 6251-133-1999 |
| UK:               | +44 (0) 800-267666    |
| France:           | +33 (0) 1-3420-8686   |
| Netherlands:      | +31 (0) 73-6246-999   |
| China:            | +86 (0) 400-820-6015  |

### te.com

TE Connectivity, TE, TE connectivity (logo), Linx and Linx Technologies are trademarks owned or licensed by the TE Connectivity Ltd. family of companies. All other logos, products and/or company names referred to herein might be trademarks of their respective owners.

The information given herein, including drawings, illustrations and schematics which are intended for illustration purposes only, is believed to be reliable. However, TE Connectivity makes no warranties as to its accuracy or completeness and disclaims any liability in connection with its use. TE Connectivity's obligations shall only be as set forth in TE Connectivity's Standard Terms and Conditions of Sale for this product and in no case will TE Connectivity be liable for any incidental, indirect or consequential damages arising out of the sale, resale, use or misuse of the product. Users of TE Connectivity products should make their own evaluation to determine the suitability of each such product for the specific application.

TE Connectivity warrants to the original end user customer of its products that its products are free from defects in material and workmanship. Subject to conditions and limitations TE Connectivity will, at its option, either repair or replace any part of its products that prove defective because of improper workmanship or materials. This limited warranty is in force for the useful lifetime of the original end product into which the TE Connectivity product is installed. Useful lifetime of the original end product may vary but is not warranted to exceed one (1) year from the original date of the end product purchase.

©2023 TE Connectivity. All Rights Reserved.

05/23 Original