

MODEL NO.	PACKAGING
145-0711-812	ONE PCS PER BAG

REV	ECO	DATE
001	ECO-19-0024	07/05/2019

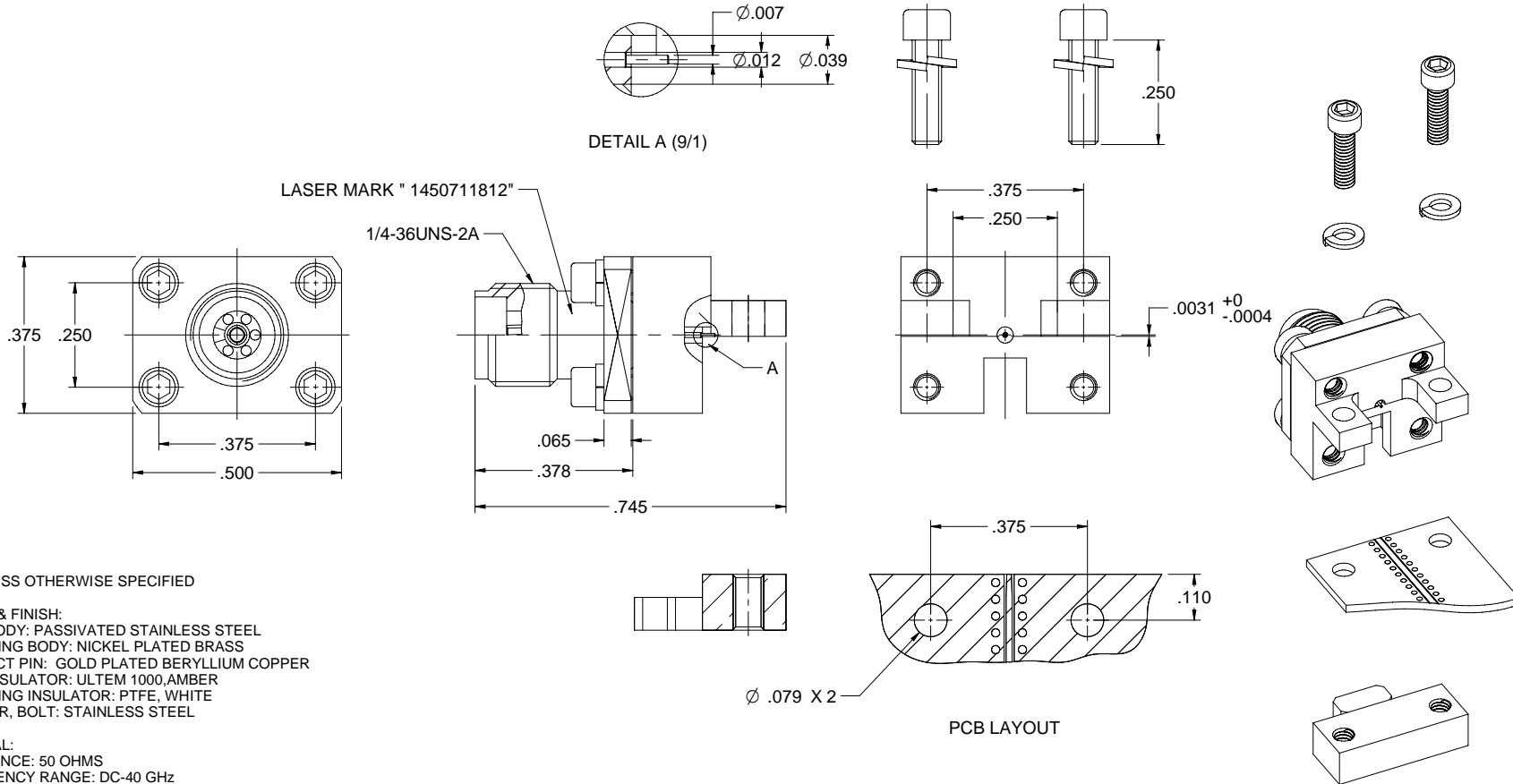

NOTES: UNLESS OTHERWISE SPECIFIED

1. MATERIAL & FINISH:

- 1.1 MAIN BODY: PASSIVATED STAINLESS STEEL
- 1.2 MOUNTING BODY: NICKEL PLATED BRASS
- 1.3 CONTACT PIN: GOLD PLATED BERYLLIUM COPPER
- 1.4 MAIN INSULATOR: ULTEM 1000, AMBER
- 1.5 MOUNTING INSULATOR: PTFE, WHITE
- 1.6 WASHER, BOLT: STAINLESS STEEL

2. ELECTRICAL:

- 2.1 IMPEDANCE: 50 OHMS
- 2.2 FREQUENCY RANGE: DC-40 GHz
- 2.3 VOLTAGE STANDING WAVE RATIO: 1.2 MAX
- 2.4 DIELECTRIC WITHSTANDING VOLTAGE: 750 VRMS MIN
- 2.5 CONTACT RESISTANCE:
  - 2.5.1 CENTER CONTACT: 3 MILLIOHMS MAX
  - 2.5.2 OUTER CONTACT: 2 MILLIOHMS MAX

3. MECHANICAL:

- 3.1 DURABILITY: 500CYCLES MIN

4. ENVIRONMENT:

- 4.1 OPERATING TEMPERATURE: -55 TO 125°C
- 4.2 THERMAL SHOCK: MIL-STD-202, METHOD 107, CONDITION B.
- 4.3 SHOCK: MIL-STD-202, METHOD 213, CONDITION I
- 4.4 VIBRATION: MIL-STD-202, METHOD 204, CONDITION D
- 4.5 MOISTURE RESISTANCE: MIL-STD-202, METHOD 106
- 4.6 SALT SPRAY: MIL-STD-202, METHOD 101, CONDITION B

	Model No.	145-0711-811/820	
	RoHS2	2011/65/EU	