

Recommended P/N 20455-0\*\*E-76 (30P/40P/50P) 20455-A20E-76 (20P)

PART NO.	Pos.	A	B	C	D
20455-020E-#2	20	9.50	11.30	16.25	14.47
20455-030E-##	30	14.50	16.30	21.25	19.47
20455-040E-##	40	19.50	21.30	26.25	24.47
20455-050E-##	50	24.50	26.30	31.25	29.47

P/N:20455-0 \*\* E-##

SEE TABLE.1

Pos.



Halogen Free



RoHS Compliant

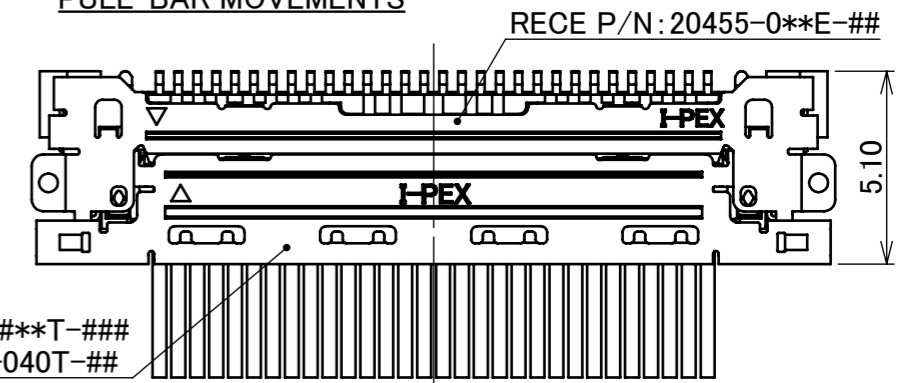
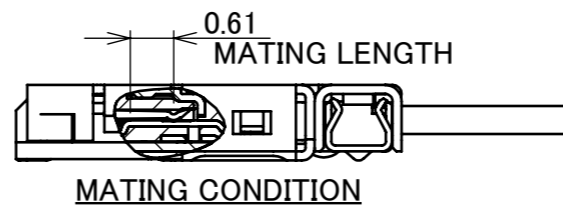
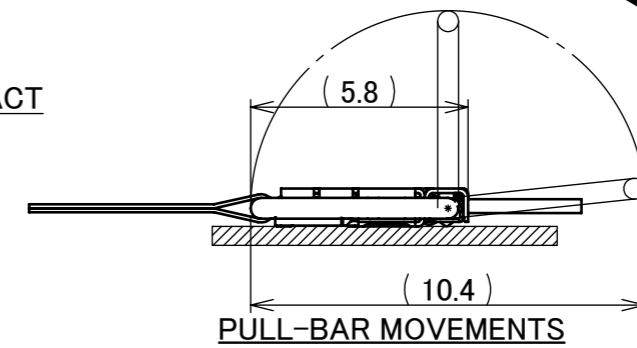
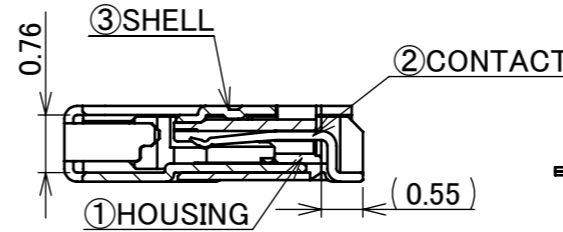
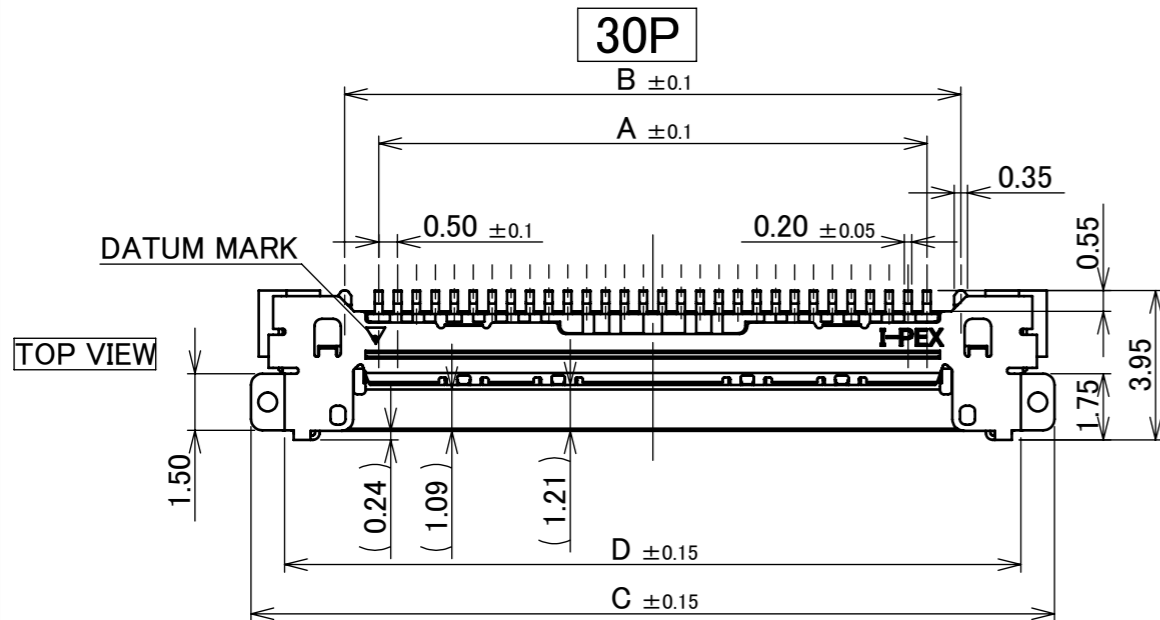
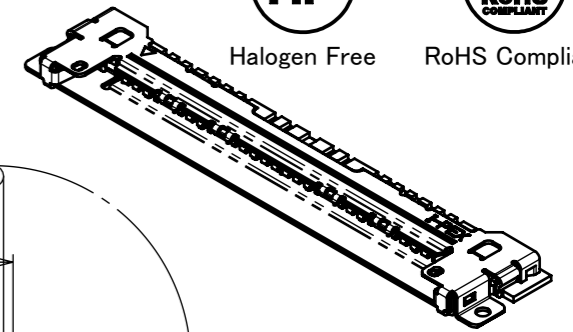

PLUG P/N: 20453-##\*T-###  
20508-040T-##

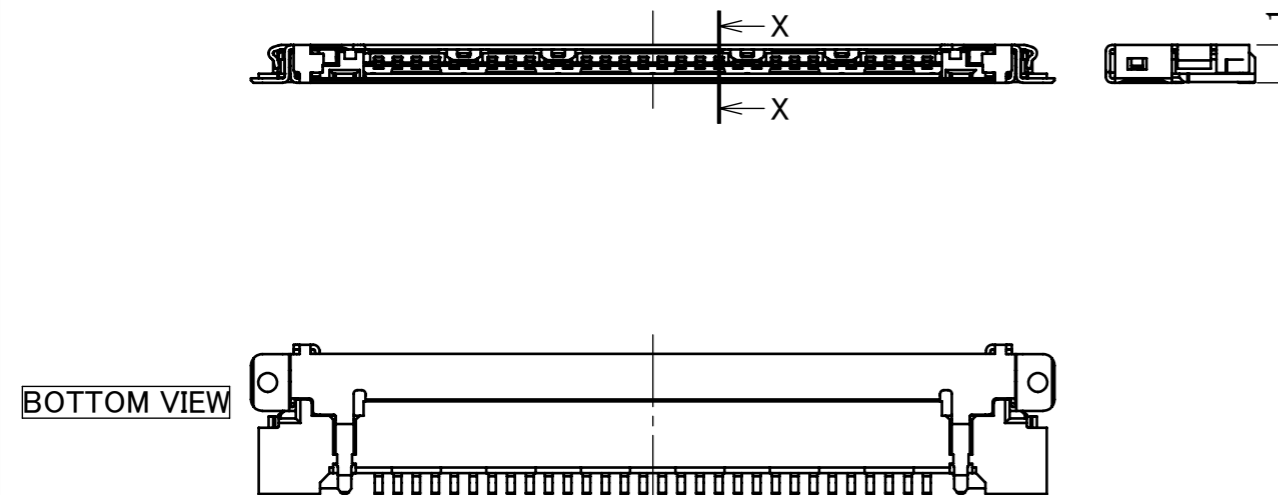

TABLE.1

PART NO.	DATUM MARK	CONTACT FINISH	SHELL FINISH
20455-0**E-02	WITH	CONTACT AREA Au 0.1 μm MIN. OVER Ni 1.00 μm MIN.	Au 0.02 μm MIN. OVER Ni 1.00 μm MIN.
20455-0**E-12	WITHOUT	SOLDERING AREA Au 0.05 μm MIN. OVER Ni 1.00 μm MIN.	
20455-0**E-66	WITH	CONTACT AREA Au 0.1 μm MIN. OVER Ni 1.00 μm MIN.	Au 0.01 μm MIN. OVER Ni 1.00 μm MIN.
20455-0**E-76	WITHOUT	SOLDERING AREA Au 0.05 μm MIN. OVER Ni 1.00 μm MIN.	

NO.	DISCRIPTION	MATERIAL	FINISH , REMARKS
3	SHELL	PHOSPHOR BRONZE	SEE ABOVE TABLE.1
2	CONTACT	PHOSPHOR BRONZE	SEE ABOVE TABLE.1
1	HOUSING	LCP	UL94V-0, BLACK

REV.	ECN	BY	DATE	APP.	APP.	DATE	DWG. No.	20455	SIZE	SHEET	REV.
29	Z211259	R.M	Oct./18/'21	H.I	ANGLE	±2°	6 OVER 30 MAX.	±0.3	PROJECTION SERIES No. R7 TITLE CABLINER <sup>®</sup> -VS RECE ASS'Y SCALE 5:1 UNIT mm A3	1/6	CUSTOMER COPY I-PEX
28	Z201153	T.Ono	Nov./05/'20	H.I	6 MAX.	±0.2	30 OVER 120 MAX.	±0.5			
27	Z190697	Y.Sasa	May/27/'19	H.I	GENERAL TOLERANCE.						
26	Z181510	Y.M	Nov./19/'18	H.I	DWG.	H.Ikari	DATE	2007/09/27			
25	Z181146	Y.M	Aug./31/'18	H.I	CHK.						
24	Z181018	A.K	Aug./02/'18	H.I							
REV.	ECN	BY	DATE	APP.	APP.	DATE	DWG. No.	20455	A3	1/6	29

Recommended P/N 20455-0\*\*E-76 (30P/40P/50P) 20455-A20E-76 (20P)

PART NO.	Pos.	A	B	C	D	H	J
20455-A20E-##	20	9.50	11.30	16.25	14.47	15.32	15.84

**TYPE-A**

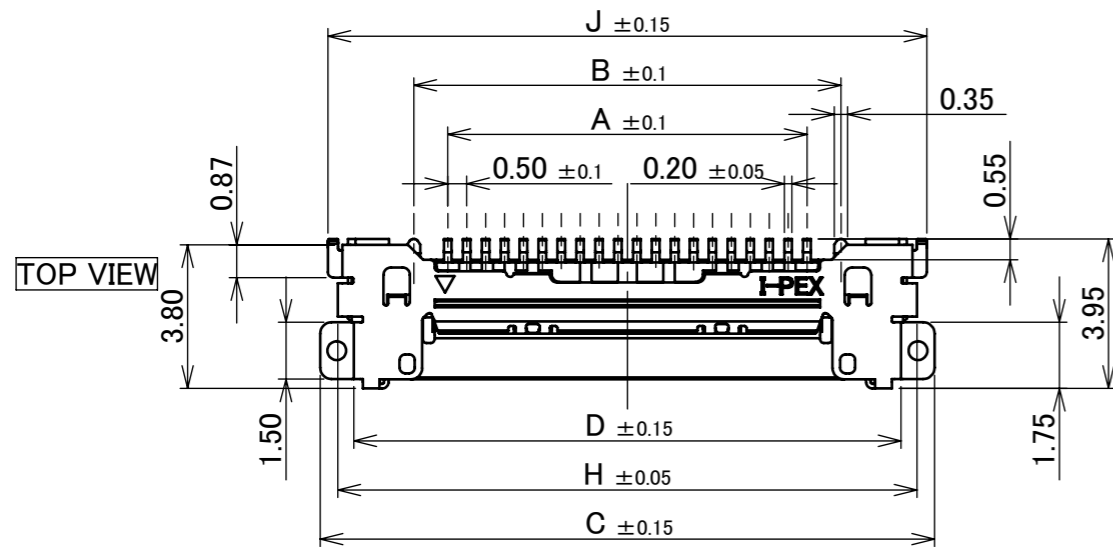

**BOTTOM VIEW**

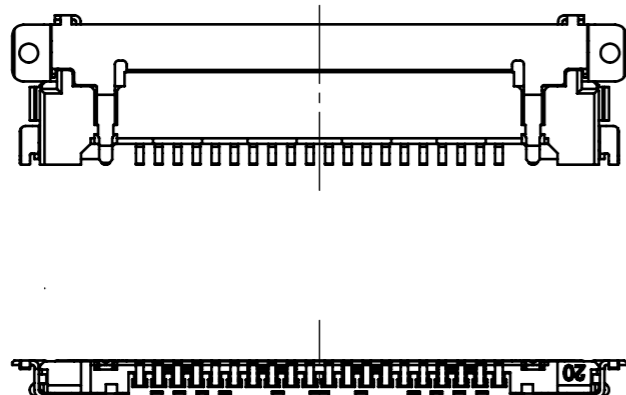

P/N:20455-A20E-##  
A : TYPE-A  
SEE TABLE.2



Halogen Free



RoHS Compliant

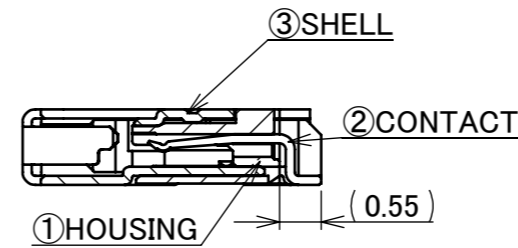
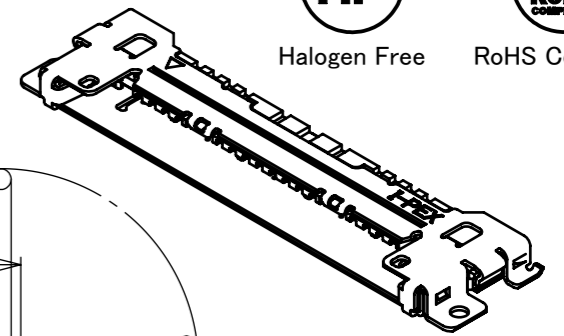

SECT X-X  
S= 10 : 1

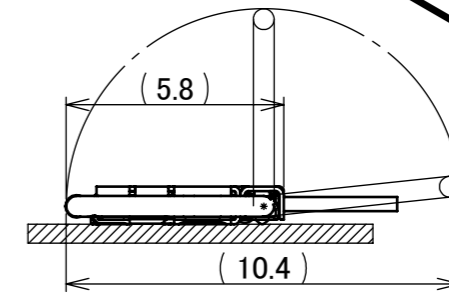

PULL-BAR MOVEMENTS

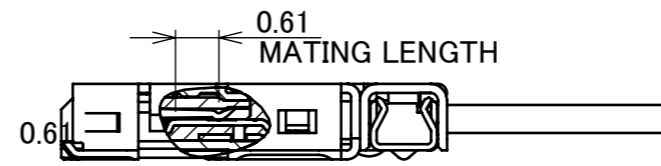

MATING CONDITION

PLUG P/N: 20453-020T-##

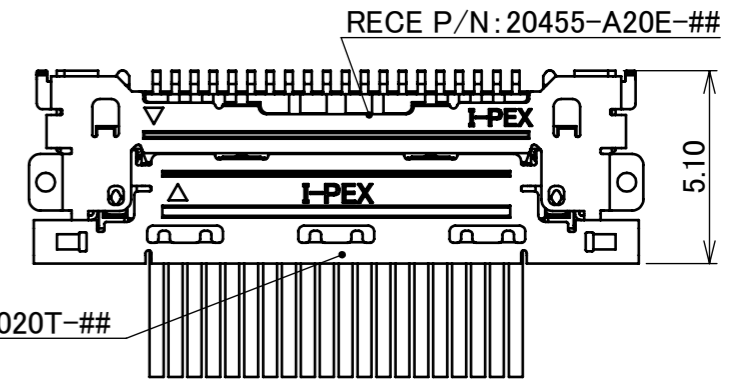

TABLE.2

PART NO.	DATUM MARK	CONTACT FINISH	SHELL FINISH
20455-A20E-02	WITH	CONTACT AREA Au 0.1 μm MIN. OVER Ni 1.00 μm MIN. SOLDERING AREA Au 0.05 μm MIN. OVER Ni 1.00 μm MIN.	Au 0.02 μm MIN. OVER Ni 1.00 μm MIN.
20455-A20E-12	WITHOUT	CONTACT AREA Au 0.1 μm MIN. OVER Ni 1.00 μm MIN. SOLDERING AREA Au 0.05 μm MIN. OVER Ni 1.00 μm MIN.	Au 0.01 μm MIN. OVER Ni 1.00 μm MIN.
20455-A20E-66	WITH	CONTACT AREA Au 0.1 μm MIN. OVER Ni 1.00 μm MIN. SOLDERING AREA Au 0.05 μm MIN. OVER Ni 1.00 μm MIN.	Au 0.01 μm MIN. OVER Ni 1.00 μm MIN.
20455-A20E-76	WITHOUT	CONTACT AREA Au 0.1 μm MIN. OVER Ni 1.00 μm MIN. SOLDERING AREA Au 0.05 μm MIN. OVER Ni 1.00 μm MIN.	Au 0.01 μm MIN. OVER Ni 1.00 μm MIN.

NO.	DISCRIPTION	MATERIAL	FINISH , REMARKS
3	SHELL	PHOSPHOR BRONZE	SEE ABOVE TABLE.1
2	CONTACT	PHOSPHOR BRONZE	SEE ABOVE TABLE.1
1	HOUSING	LCP	UL94V-0, BLACK

REVISION RECORD					ANGLE	±2°	6 OVER 30 MAX.	±0.3	PROJECTION ⊕	SERIES No. R7	CUSTOMER COPY		
						6 MAX.	±0.2	30 OVER 120 MAX.			±0.5	TITLE CABLIN® -VS RECE ASS'Y	SCALE
					GENERAL TOLERANCE.				DWG. No. 20455	UNIT	I-PEX		
					DWG.	DATE				SIZE	SHEET	REV.	
					CHK.					A3	2/6	29	
REV.	ECN	BY	DATE	APP.	APP.								

PART NO.	Pos.	A	B	E	F	G	H	J	K
20455-#20E-##	20	9.50	11.30	14.30	10.60	18.20	15.32	15.84	14.84
20455-030E-##	30	14.50	16.30	19.30	15.60	23.20	-	-	-
20455-040E-##	40	19.50	21.30	24.30	20.60	28.20	-	-	-
20455-050E-##	50	24.50	26.30	29.30	25.60	33.20	-	-	-

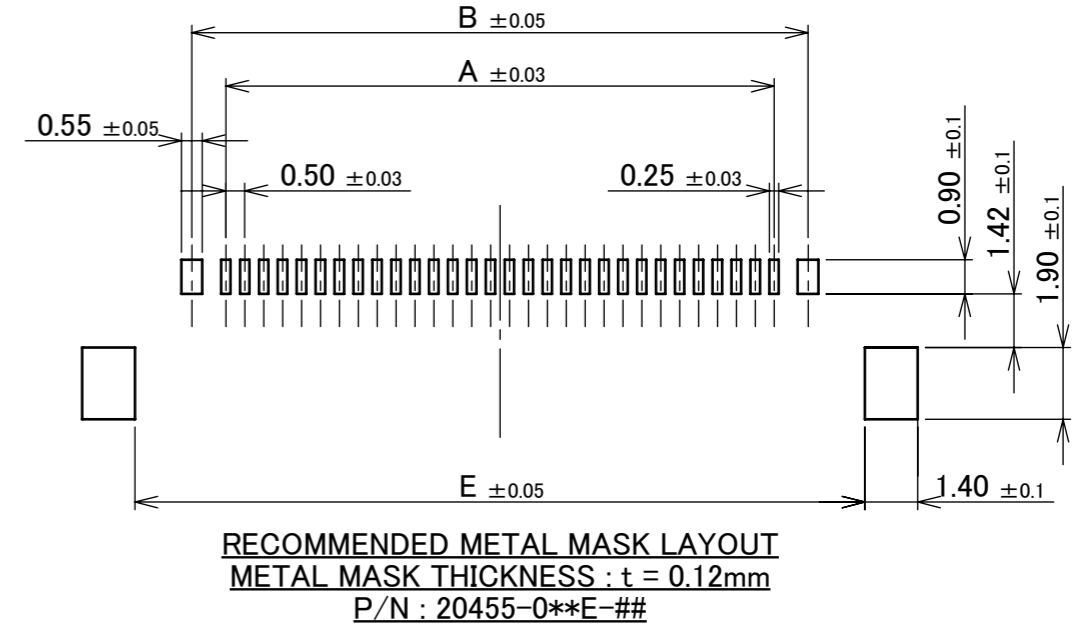
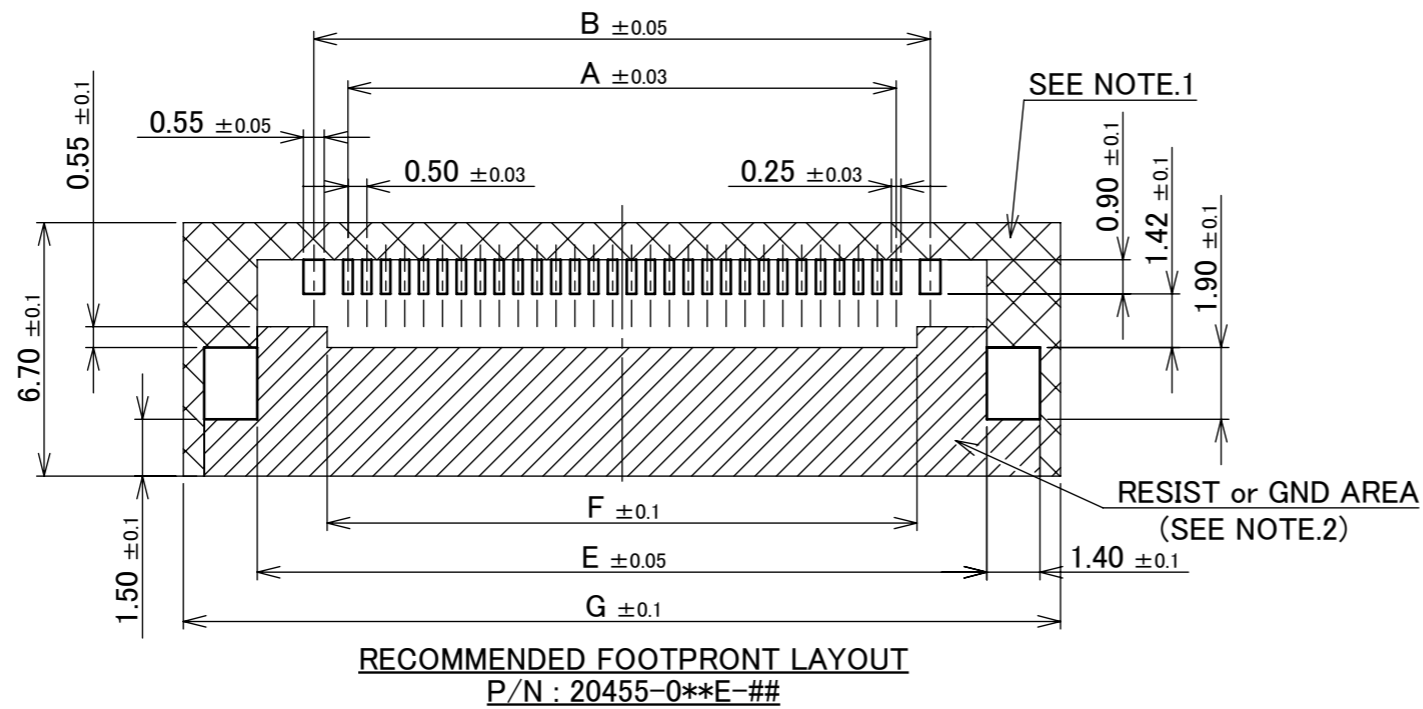

**TYPE-A**

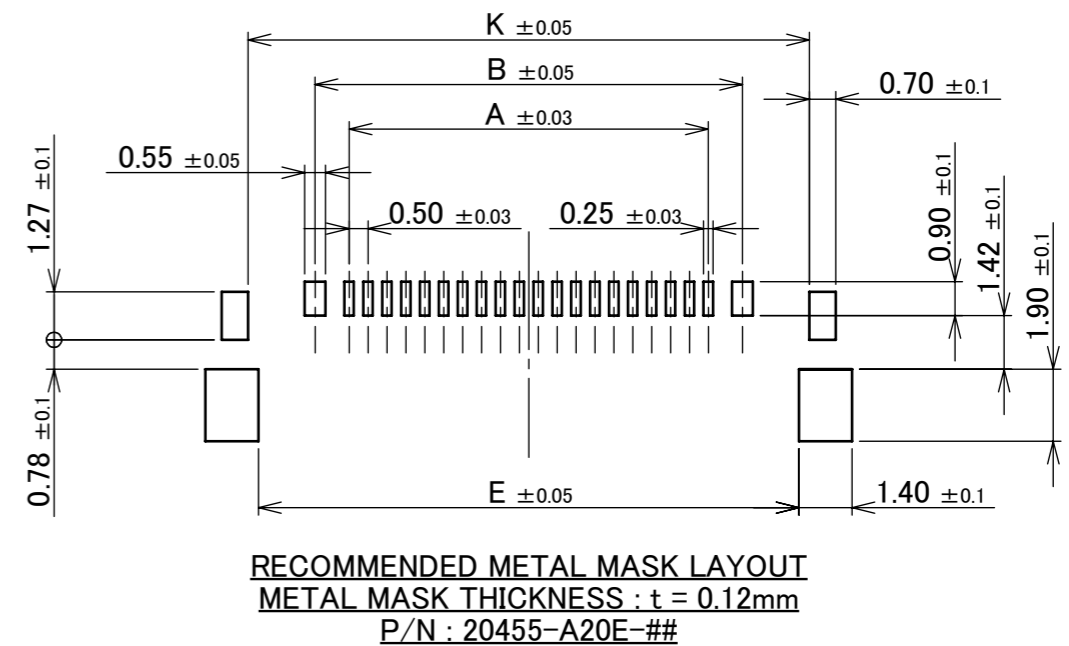
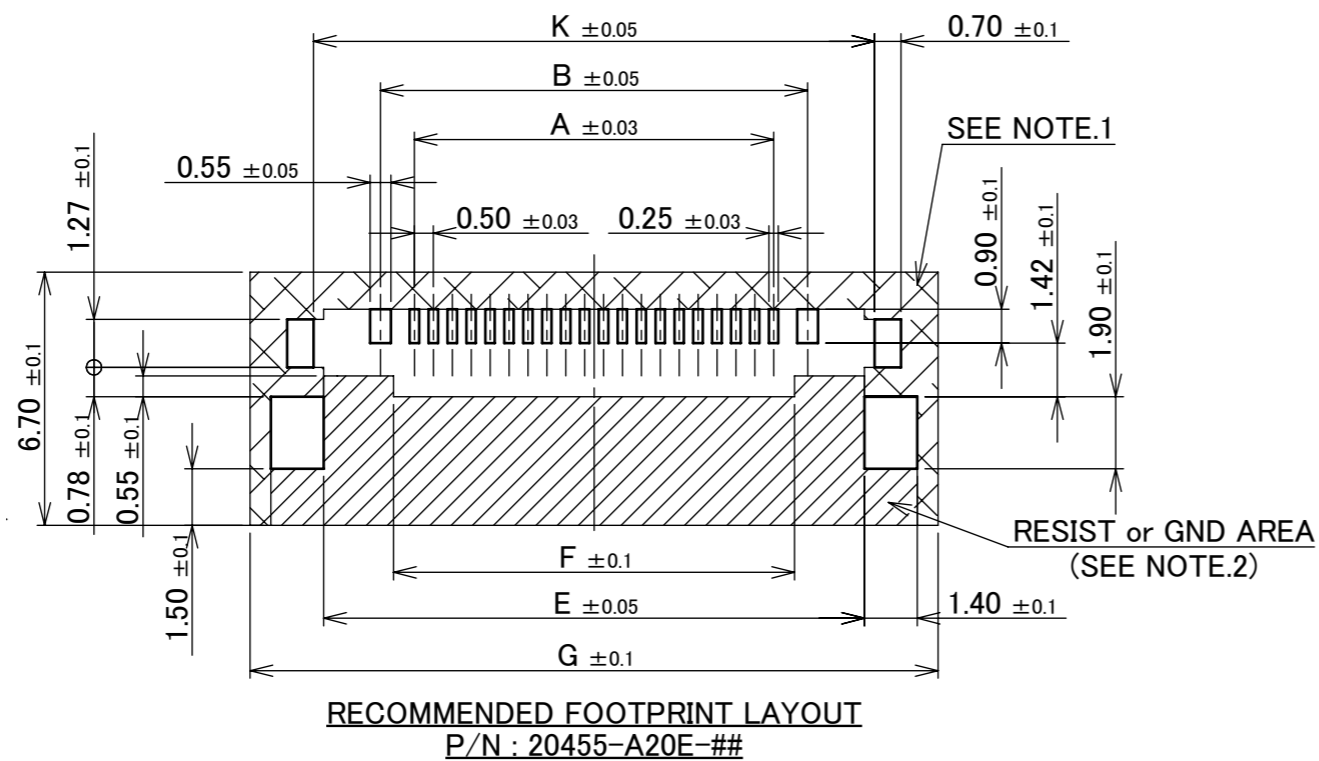

**NOTES.**

1. IN CASE OF PLUG WITH PULL-BAR, THIS AREA CANNOT MOUNT ANOTHER COMPONENTS.
2. SOLDER RESIST SHALL BE APPLIED TO PREVENT SHORT CIRCUITS WHEN PLACING SIGNAL LINES ON GROUND AREA.

ANGLE	±2°	6 OVER 30 MAX.	±0.3	PROJECTION ⊕	SERIES No. R7	CUSTOMER COPY		
6 MAX.	±0.2	30 OVER 120 MAX.	±0.5					
GENERAL TOLERANCE.				TITLE CABLIN <sup>®</sup> -VS RECE ASS'Y	SCALE 5:1	<b>I-PEX</b>		
DWG.	DATE							
CHK.								
APP.								
				DWG. No.	20455	SIZE A3	SHEET 3/6	REV. 29

ITEMS	SPECIFICATION
APPLICABLE CABLE	MICRO COAX : AWG# 44, 42, 40, 38, 36 DISCRETE : AWG# 36, 34, 32 TWINCOAX : AWG# 40
RATING VOLTAGE	100V AC (PER CONTACT)
RATING AMPERAGE (FOR CONTACT)	0.1A AC/DC [AWG#44] PER CONTACT/UP TO 50 CONTACTS 0.24A AC/DC [AWG#42] PER CONTACT/UP TO 50 CONTACTS 0.3A AC/DC [AWG#40] PER CONTACT/UP TO 50 CONTACTS 0.5A AC/DC [AWG#38] PER CONTACT/UP TO 14 CONTACTS 0.8A AC/DC [AWG#36] PER CONTACT/UP TO 10 CONTACTS 1.0A AC/DC [AWG#34] PER CONTACT/UP TO 6 CONTACTS 1.0A AC/DC [AWG#32] PER CONTACT/UP TO 6 CONTACTS TESTING BY A REAL MACHINE IS RECOMMENDED BECAUSE TEMPURECHER RISE MAY AFFECTED BY ACTUAL SITUATION.
OPERATING TEMPERATURE	233~358K(-40°C~+85°C)
OPERATING HUMIDITY	85% R.H. MAX.(NON-CONDENSING)
CONTACT RESISTANCE	INITIAL : 140mohm MAX.(AWG#32) / AFTER TEST : $\triangle$ 40mohm MAX. 180mohm MAX.(AWG#34) 275mohm MAX.(AWG#36) 360mohm MAX.(AWG#38) 600mohm MAX.(AWG#40) 700mohm MAX.(AWG#42) 1080mohm MAX.(AWG#44)
GROUND SHELL RESISTANCE	INITIAL : 50mohm MAX. / AFTER TEST : $\triangle$ 40mohm MAX.
INSULATION RESISTANCE	INITIAL : 1000Mohm MIN. / AFTER TEST : 500Mohm MIN.
DIELECTRIC WITHSTANDING VOLTAGE	AC250V 1min
DURABILITY	30 CYCLES
MATING FORCE (INITIAL / AFTER TEST)	20P : 9.45N MAX. 30P : 12.15N MAX. 40P : 16.20N MAX. 50P : 20.25N MAX.
UNMATING FORCE (INITIAL / AFTER TEST)	20P : 2.0N MIN. 30P : 3.0N MIN. 40P : 4.0N MIN. 50P : 5.0N MIN.
CABLE RETENTION FORCE	20P : 9.80N MIN. 30P : 14.70N MIN. 40P : 19.60N MIN. 50P : 24.50N MIN.
COPLANARITY	0.10 MAX.
PRODUCT SPECIFICATION	PRS-1427
TEST REPORT	TR-08047 (20455-***E-#2) TR-13084 (20455-***E-#6, 20455-0**E-#8)
PACKING STANDARD	300-643
INSTRUCTION MANUAL	HIM-08004
APPEARANCE CRITERIA NO.	QLS-A***

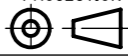
ANGLE	$\pm 2^\circ$	6 OVER 30 MAX.	$\pm 0.3$	PROJECTION 	SERIES No. R7	CUSTOMER COPY		
	6 MAX.	$\pm 0.2$	30 OVER 120 MAX.					$\pm 0.5$
GENERAL TOLERANCE.				TITLE CABLIN <sup>®</sup> -VS RECE ASS'Y	SCALE 5:1 UNIT mm	I-PEX		
DWG.	DATE							
CHK.								
APP.								
				DWG. No.	20455	SIZE A3	SHEET 4/6	REV. 29

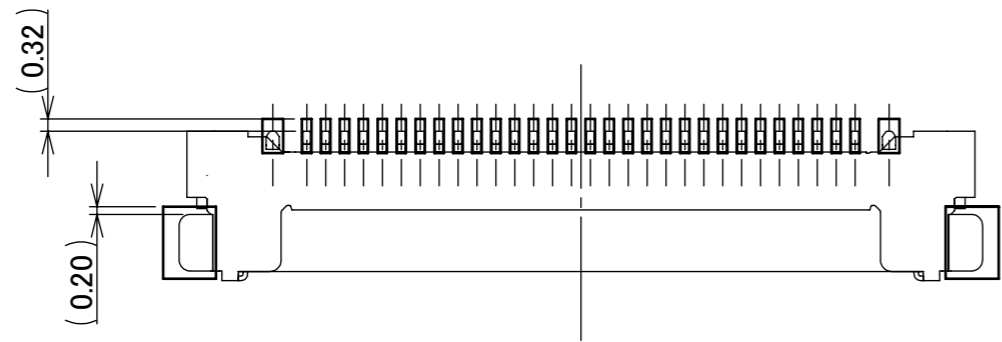

CONNECTOR ON RECOMMENDED FOOTPRINT PATTERN  
P/N : 20455-0\*\*E-##

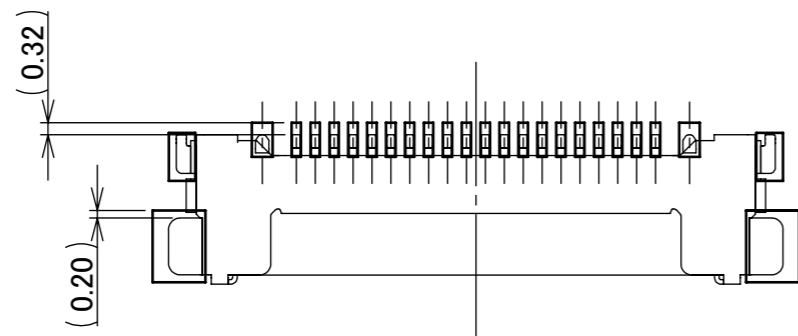

TYPE-A

CONNECTOR ON RECOMMENDED FOOTPRINT PATTERN  
P/N : 20455-A20E-##

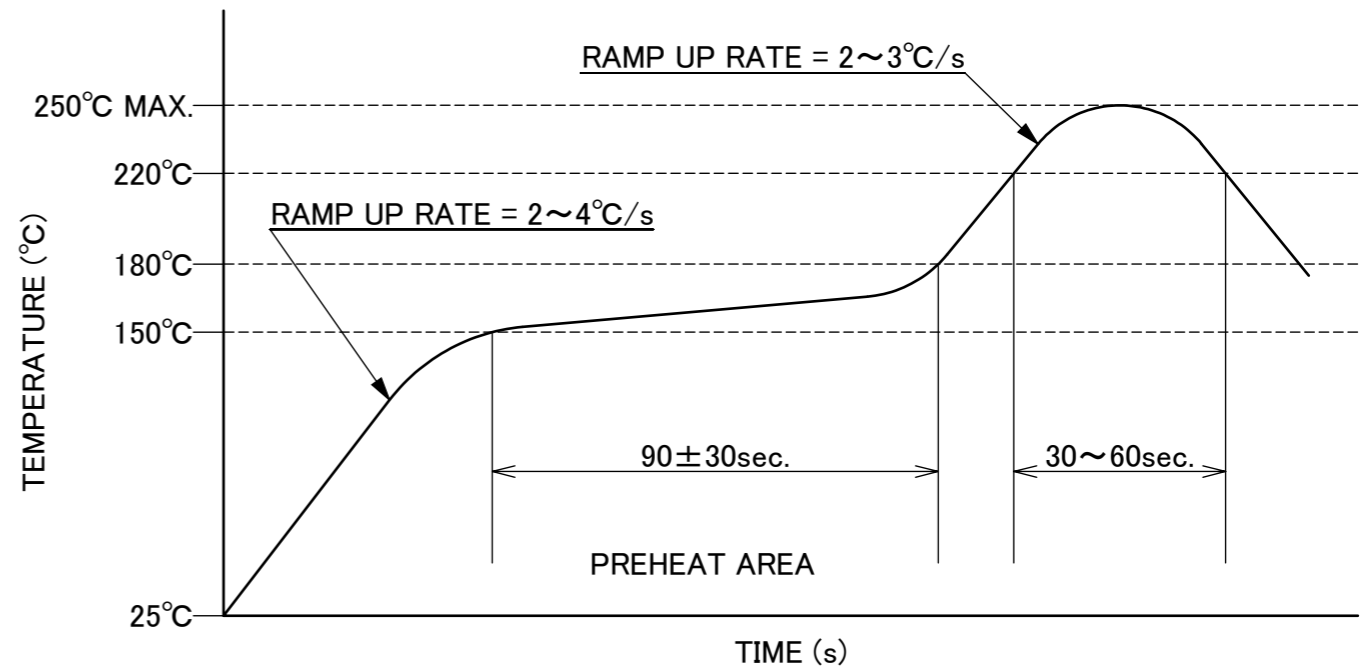

REFLOW TEMPERATURE PROFILE  
SENJU METAL INDUSTRY CO., LTD. : M705-SHF(Sn96.5 Ag3.0 Cu0.5)

ANGLE	±2°	6 OVER 30 MAX.	±0.3	PROJECTION ⊕	SERIES No. R7	CUSTOMER COPY				
6 MAX.	±0.2	30 OVER 120 MAX.	±0.5							
GENERAL TOLERANCE.				TITLE CABLINE® -VS RECE ASS'Y		SCALE	<b>I-PEX</b>			
DWG.	DATE					5:1				
CHK.						UNIT				mm
APP.						SIZE				SHEET
				DWG. No.	20455	A3	5/6	29		

PART NO.	L	M	N	P	Q	R	S	T	QTY. PER EMBOSS REEL (PIECES / REEL)	QTY. PER PACKING CARTON (REELS / CARTON)
20455-#20E-##	24.0	11.5	-	11.7	16.2	14.6	11.1	16.6	5000 / REEL	5 REELS / CARTON = 25000
20455-030E-##	32.0	14.2	28.4	16.7	21.2	19.6	16.1	21.6		3 REELS / CARTON = 15000
20455-040E-##	44.0	20.2	40.4	21.7	26.2	24.6	21.1	26.6		3 REELS / CARTON = 15000
20455-050E-##	44.0	20.2	40.4	26.7	31.2	29.6	26.1	31.6		3 REELS / CARTON = 15000

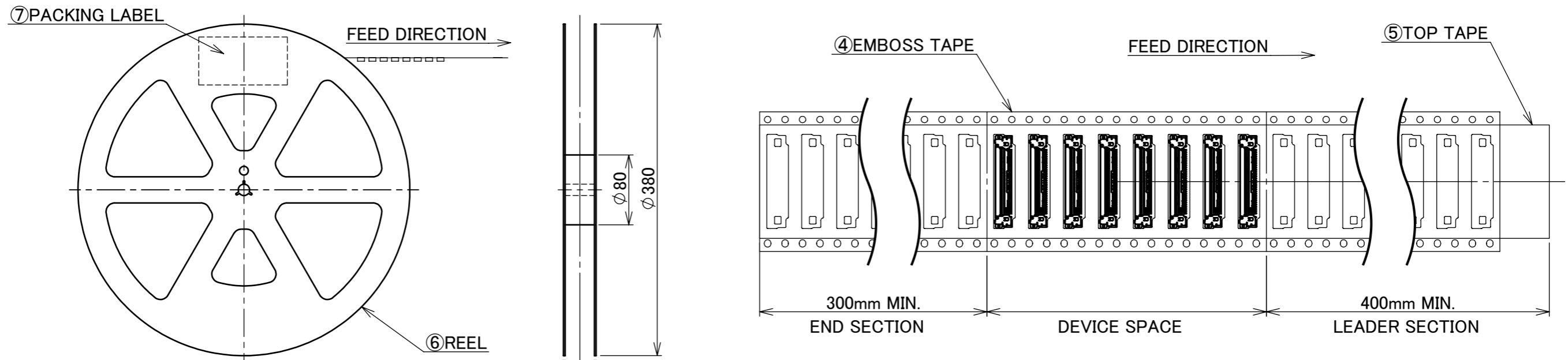

- NOTES.
- TAPING SPECIFICATION FOLLOWS JIS C 0806 (IEC 60286-3).
  - MAKE EMPTY SECTION OF LEADER AND END ON EACH END OF THE TAPE.
  - TOP TAPE SHALL NOT STICK OUT FROM EMBOSS TAPE.
  - TOP TAPE SHALL NOT COVER FEED HOLE.

NO.	DISCRIPTION	MATERIAL	FINISH , REMARKS
7	PACKING LABEL	-	-
6	REEL	PS	ANTI-STATIC TYPE BLACK
5	TOP TAPE	PET t=0.062 TRANSPARENCY	ANTI-STATIC TYPE
4	EMBOSS TAPE	PS t=0.3 TRANSPARENCY	ANTI-STATIC TYPE

ANGLE	±2°	6 OVER 30 MAX.	±0.3	PROJECTION	SERIES No.	CUSTOMER COPY	
6 MAX.	±0.2	30 OVER 120 MAX.	±0.5		R7	SCALE	<b>I-PEX</b>
GENERAL TOLERANCE.						TITLE	
DWG.	DATE			CABLIN <sup>®</sup> -VS RECE ASS'Y		mm	SHEET 6/6
CHK.				DWG. No.		REV.	
APP.				20455		29	

Confidential C

I-PEX Inc.

QKE-DFE06-02 REV.12