

Halogen free SHOW AS 60PIN

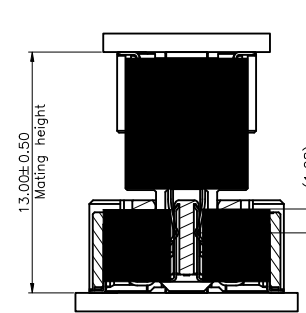

SECTION X-X
 FLOATING RANGE TOWARD X
 X DIRECTION: ±0.60
 Y DIRECTION: ±0.60
 Z DIRECTION: ±0.50
 ASSEMBLY DRAWING

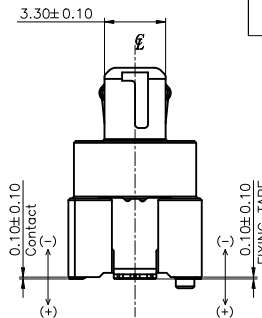
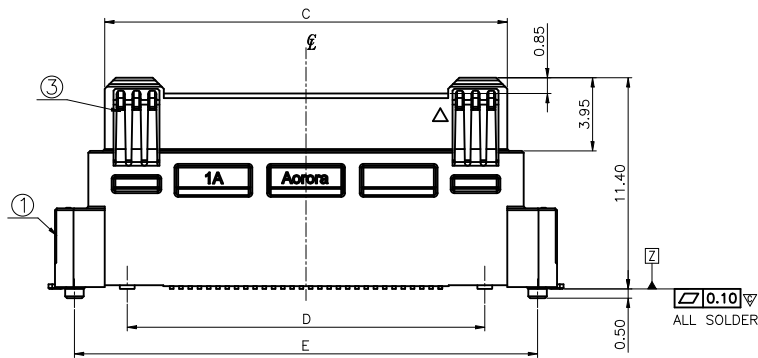
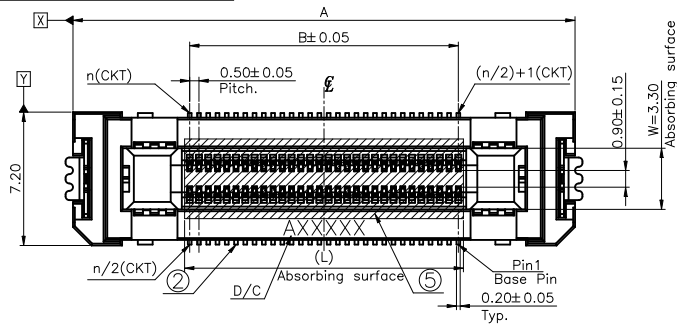
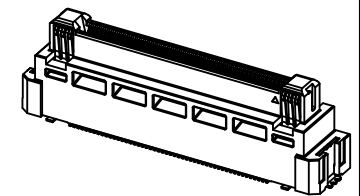

3D VIEW.

DIMENSION LIST:

| PIN No. | A | B | C | D | E | L |
|---------|-------|-------|-------|-------|-------|-------|
| 10 | 14.60 | 2.00 | 9.23 | 6.80 | 12.50 | 2.55 |
| 20 | 17.10 | 4.50 | 11.73 | 9.30 | 15.00 | 5.05 |
| 30 | 19.60 | 7.00 | 14.23 | 11.80 | 17.50 | 7.55 |
| 40 | 22.10 | 9.50 | 16.73 | 14.30 | 20.00 | 10.05 |
| 50 | 24.60 | 12.00 | 19.23 | 16.80 | 22.50 | 12.55 |
| 60 | 27.10 | 14.50 | 21.73 | 19.30 | 25.00 | 15.05 |
| 70 | 29.60 | 17.00 | 24.23 | 21.80 | 27.50 | 17.55 |
| 80 | 32.10 | 19.50 | 26.73 | 24.30 | 30.00 | 20.05 |
| 90 | 34.60 | 22.00 | 29.23 | 26.80 | 32.50 | 22.55 |
| A0(100) | 37.10 | 24.50 | 31.73 | 29.30 | 35.00 | 25.05 |
| B0(120) | 42.10 | 29.50 | 36.73 | 34.30 | 40.00 | 30.05 |
| A3(130) | 44.60 | 32.00 | 39.23 | 36.80 | 42.50 | 32.55 |
| A4(140) | 47.10 | 34.50 | 41.73 | 39.30 | 45.00 | 35.05 |

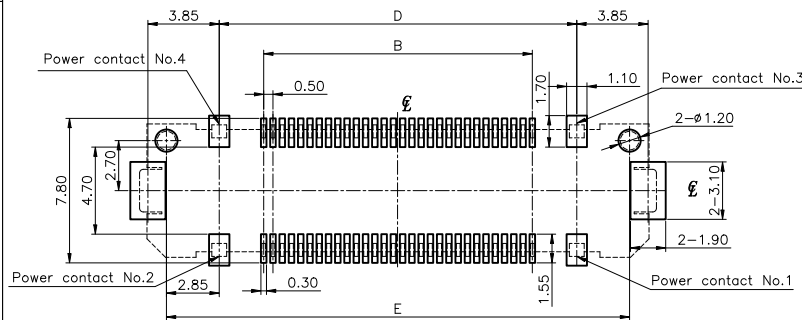
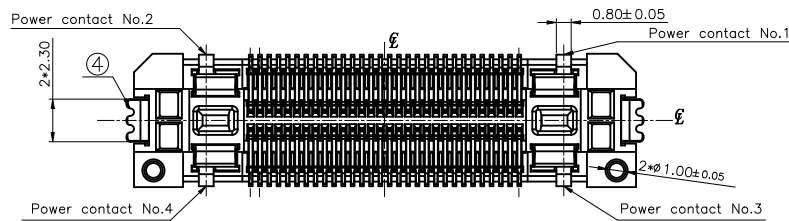

RECOMMENDED PCB SIZE(TOP SIDE)
 GENERAL TOLERANCE:±0.05

| REV. | ECR/ECN No. | DESCRIPTION | DRAWN/DATE | CHECKED/DATE | APPROVED/DATE |
|------|-------------|-------------------|-----------------------|---------------------|--------------------|
| A | / | New Release | SH Chen 2022-10-20 | May 2022-10-20 | Rain 2022-10-20 |
| B | / | Update appearance | SH Chen 2022-11-30 | May 2022-11-30 | Rain 2022-11-30 |
| C | / | Add Pin Number | SH Chen 2024-03-04 | Elven 2024-03-04 | Rain 2024-03-04 |

| NO. | COMPONENTS | MATERIALS | SPECIFICATION:FINISH/COLOR | QTY. |
|-----|----------------|------------------------------|---|------|
| 1 | HOUSING | GLASS FILLED LCP, UL94V-0 | BLACK | 1 |
| 2 | SIGNAL CONTACT | COPPER ALLOY T=0.15mm | ALL OVER Ni UNDER PLATING:40u''~120u'' CONTACT AREA: Au 4u'' MIN. SOLDER AREA: Au 2u'' Min. | N |
| 3 | POWER CONTACT | COPPER ALLOY T=0.20mm | ALL OVER Ni UNDER PLATING:40u''~120u'' CONTACT AREA: Au 4u'' Min. SOLDER AREA: Au 2u'' Min. | 4 |
| 4 | FIXING TAP | COPPER ALLOY T=0.25mm | ALL OVER Ni UNDER PLATING:40u''~120u'' SOLDER AREA: Au 2u'' Min. | 2 |
| 5 | MYLAR | THERMOSTABLE T=0.10mm | YELLOW | 1 |

- NOTES:
 1. BURRS OF CONTACT AREA ARE NOT ALLOWED AND INTERPOSITION AREA SHOULD BE 0.03MM MAX.
 2. "∇" MARK IS CRITICAL CHARACTERISTIC DIMENSION.
 3. ALL MATERIAL MUST BE COMPLY RoHS.
 4. D/C:AXXXXX
 Aorora — SHIFT
 YEAR — LINE
 MONTH — DAY
 5. RECE. PART NO.:B329-1B7L1-112**-E100 SERIES
 6. PLUG PART NO.: B344-1B7L1-112**-E100

| UNLESS OTHERWISE SPECIFIED TOLERANCES | | ANGLE OF PROJECTION | | Customer Drw | TITLE: FloatCombo™ 0.5mm Pitch SH13 Floating BTB Plug Conn. |
|---------------------------------------|-----------------------|---------------------|-------|--------------|---|
| X. | ±0.30 | X. ° | ± 5' | | |
| X.X | ±0.25 | X.X ° | ± 4' | DRAWN | DATE |
| X.XX | ±0.20 | X.XX ° | ± 3' | SH Chen | 2024-03-04 |
| X.XXX | ±0.15 | X.XXX ° | ± 2' | DESIGN | DATE |
| LINEAR DIMS | | ANGLES DIMS | | SH Chen | 2024-03-04 |
| DWG NO.: | A-S0798 | | | CHECKED | DATE |
| MATERIAL | SEE NOTES | | | Elven | 2024-03-04 |
| FINISHED | SEE NOTES | | | APPROVED | DATE |
| | | | | Rain | 2024-03-04 |
| SIZE | PART NUMBER: | | REV. | | |
| A4 | B344-1B7L1-112**-E100 | | C | | |
| SCALE | 4:1 | UNIT : mm | SHEET | 1 OF 2 | |

This document is the property of and embodies CONFIDENTIAL and PROPRIETARY information of AOR. No part of the information shown on this document may be used in any way or disclosed to others without the written consent of AOR. © 2019 AOR

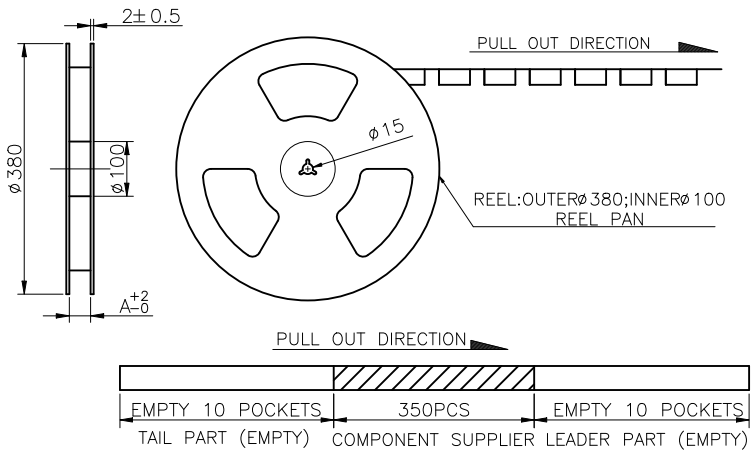
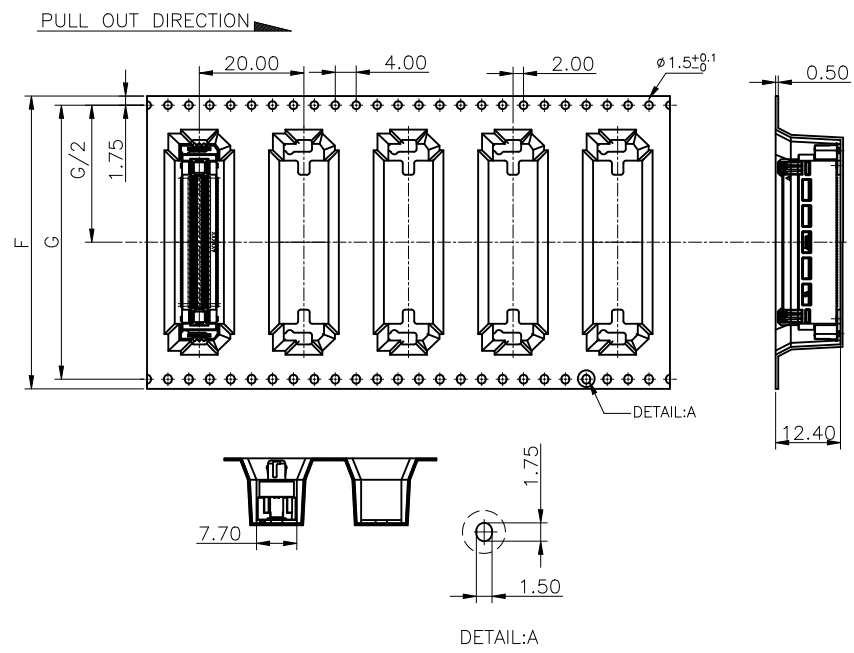

5. QTY LIST:

| DIM NO. | 10pin | 20~60pin | 70~100pin | 120~140pin |
|------------|-------|----------|-----------|------------|
| F | 32.00 | 44.00 | 56.00 | 72.00 |
| G | 25.50 | 40.40 | 52.40 | 68.40 |
| N | 8 | 6 | 5 | 4 |
| TOTAL(PCS) | 2800 | 2100 | 1750 | 1400 |

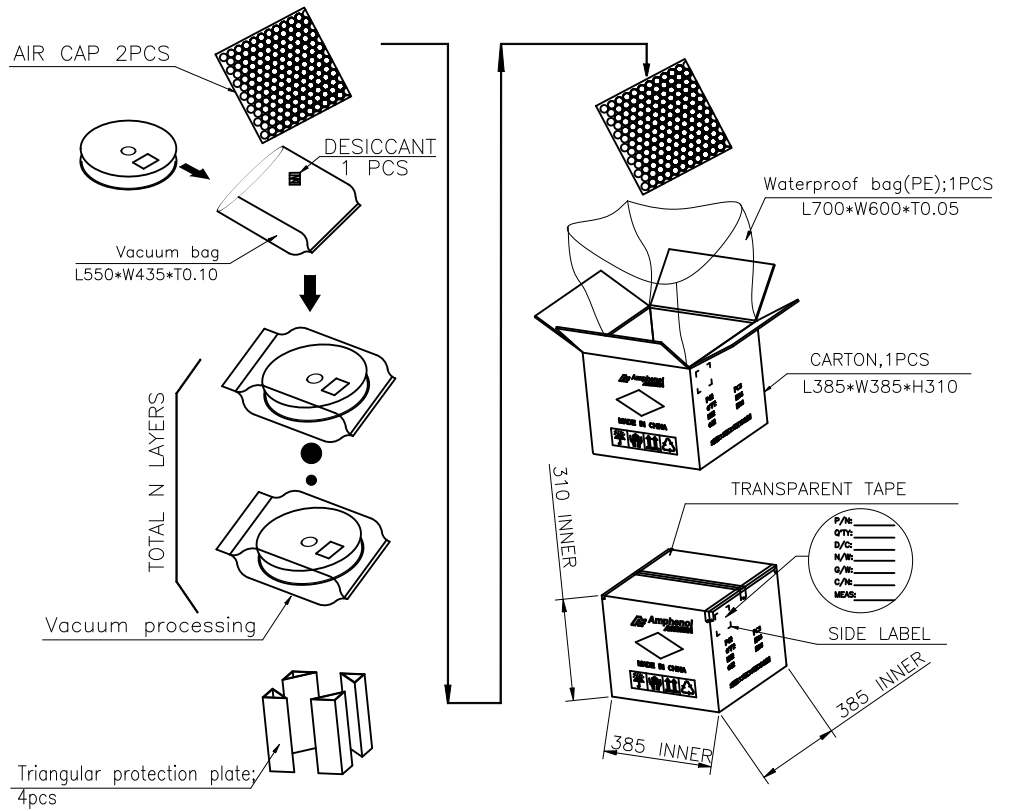

NOTES:

- MATERIAL:
 - CARRY TAPE:HIPS,T=0.50mm,CLEAR
 - REEL:HIPS,BLUE.
 - SHIM:PE,CLEAR.
- PRIMARY PACKING:350PCS/REEL.
- SECONDARY PACKING:"N" REELS/CARTON ("TOTAL"=N*350/CARTON).
- PEELING RESISTANCE: 0.4N~1.4N(40~140gf);
PEELING ANGLE: 165°~180°;
PEELING SPEED: 300mm/minutes.

| UNLESS OTHERWISE SPECIFIED TOLERANCES | | | ANGLE OF PROJECTION | | Amphenol AORORA | |
|---------------------------------------|-------|-------------|---------------------|--------------|-----------------|---|
| X. | ±0.30 | X. * | ± 5' | | | Amphenol Aorora Technology (Huizhou) Co.,Ltd |
| X.X | ±0.25 | X.X * | ± 4' | | | |
| X.XX | ±0.20 | X.XX * | ± 3' | DOC TYPE | | TITLE: FloatCombo™ 0.5mm Pitch SH13 Floating BTB Plug Conn. |
| X.XXX | ±0.15 | X.XXX * | ± 2' | Customer Drw | | |
| LINEAR DIMS | | ANGLES DIMS | | DRAWN | DATE | SIZE |
| DWG NO.: A-S0798 | | | | DATE | SH Chen | |
| MATERIAL | | SEE NOTES | | DESIGN | DATE | REV. |
| FINISHED | | SEE NOTES | | DATE | SH Chen | |
| | | | | DATE | Elven | UNIT : mm |
| | | | | DATE | Rain | |
| | | | | DATE | 2024-03-04 | |

This document is the property of and embodies CONFIDENTIAL and PROPRIETARY information of AOR. No part of the information shown on this document may be used in any way or disclosed to others without the written consent of AOR. © 2019 AOR