

REFER TO POLAMCO DOCUMENT ASQAW0259 FOR ASSEMBLY INSTRUCTIONS AND TOOLING.

METRIC CSA CABLES

CRIMP SIZE CODE - CSA	MAX CORE DIAMETER STANDARD CABLE	MAX CORE DIAMETER FINE STRAND CABLE
50	10,0	10,3
70	11,3	12,1
95	13,5	14,2
120	15,2	16,5
150	16,7	17,6
185	19,2	19,2
240	21,1	NA

SHELL SIZE	A THREAD CLASS 2A 0.1P-0.3L-TS	Ø B MAX	Ø C MAX	LENGTH L (STANDARD)	LENGTH L (EXTENDED)	MAX CRIMP (CSA / AWG) STANDARD CABLE	MAX CRIMP (CSA / AWG) FINE STRAND CABLE
19	1,2500	38,5	31,60	52,0	98,0	70 / 020	70 / 020
21	1,3750	41,7	34,50	54,0	103,0	120 / 040	95 / 030
23	1,5000	44,9	38,50	56,0	108,0	185 / M35	150 / M30
25	1,6250	48,0	40,64	56,0	112,0	240 / M40	185 / M35

AWG CABLES

CRIMP SIZE CODE - AWG	TO FIT CABLE SIZE*
002	2 AWG
010	0 AWG
020	00 AWG
030	000 AWG
040	0000 AWG
M30	300 MCM
M35	350 MCM
M40	400 MCM

* PLEASE NOTE:
002FS TO 040FS CRIMPS ARE DEVELOPED TO SUIT THE TE HIGH STRAND CABLE PRODUCT RANGES - E.G. ZHENS, ZHETR.

FOR ALL OTHER CABLES A SAMPLE WILL BE REQUIRED PRIOR TO ORDER PLACEMENT.

PC426HP-BT3(XL)-25-185FS-PN-1-C

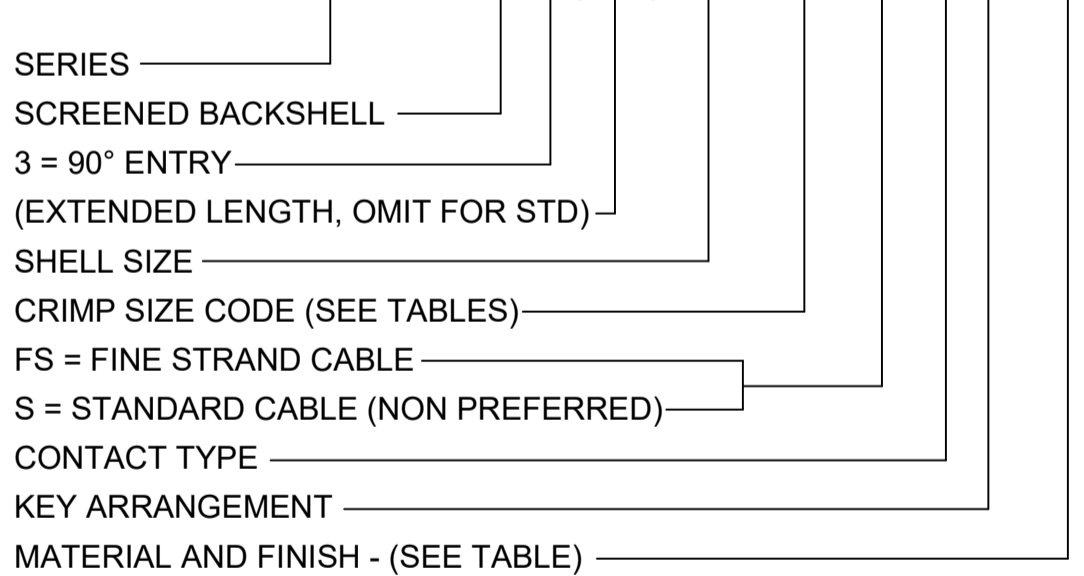

NOTES
MIL-DTL-38999 STYLE
FINISH SEE TABLE
MATERIALS CONTACT - SILVER PLATED COPPER
INSULATOR - PPS-GL40 - UL94V-0
PERFORMANCE VOLTAGE RATING 1000Va.c. / 1410Vd.c
MAX CONTACT RATING SHELL #25 = 1000A
23 = 800A
21 = 600A
19 = 400A

CODE	MATERIAL / PLATING
1-C	ALUMINIUM / ELECTROLESS NICKEL
1-B	ALUMINIUM / CADMIUM OLIVE DRAB OVER ELECTROLESS NICKEL
1-ZB	ALUMINIUM / ZINC COBALT OLIVE DRAB OVER ELECTROLESS NICKEL
1-ZN	ALUMINIUM / ZINC NICKEL BLACK PASSIVATE OVER ELECTROLESS NICKEL
4-J	STAINLESS STEEL / PASSIVATE
2-Z	NICKEL ALUMINIUM BRONZE / SHOT BLAST

LIST NOT EXHAUSTIVE, FOR COMPREHENSIVE LIST AND SPECS, SEE WEBSITE

DRAWN	M.PAUL	DATE	30/06/2021	
SALES APPR	P.M.	DATE	30/06/2021	
DESIGN APPR	M.PAUL	DATE	21/08/2014	UNLESS OTHERWISE SPECIFIED ALL DIMENSIONS IN MILLIMETRES GENERAL TOL LINEAR +/-0,25MM ANGULAR +/- 1°
PROD APPR				
QUAL APPR				MATERIAL SEE PART NUMBER BREAKDOWN FINISH SEE PART NUMBER BREAKDOWN
ISSUE	REV.	DCR		
4		8258		
NCAGE CODE U5792		WEIGHT	---	

PART NUMBER:	PC426HP-BT3(XL)-xx-xxxxx-xx-x-x		
TITLE:	90° SHIELDED HIGH POWER PLUG, CRIMP CONTACT		
ASSY USED ON:	D38999/26		
THIS DRAWING IS COPYRIGHT AND THE PROPERTY OF POLAMCO LTD IT MUST NOT BE COPIED, USED FOR MANUFACTURE OR OTHERWISE DISCLOSED WITHOUT PRIOR WRITTEN CONSENT OF THE COMPANY.		POLAMCO LTD, WESTON LOCK, LOWER BRISTOL ROAD BATH BA2 1EP	SHT 1

Polamco
TE connectivity

DRAWING NO:
C3958