

Data Sheet | Item Number: 855-301/060-101

Plug-in current transformer; Primary rated current: 60 A; Secondary rated current: 1 A;

Rated power: 1.25 VA; Accuracy class: 1

<https://www.wago.com/855-301/060-101>

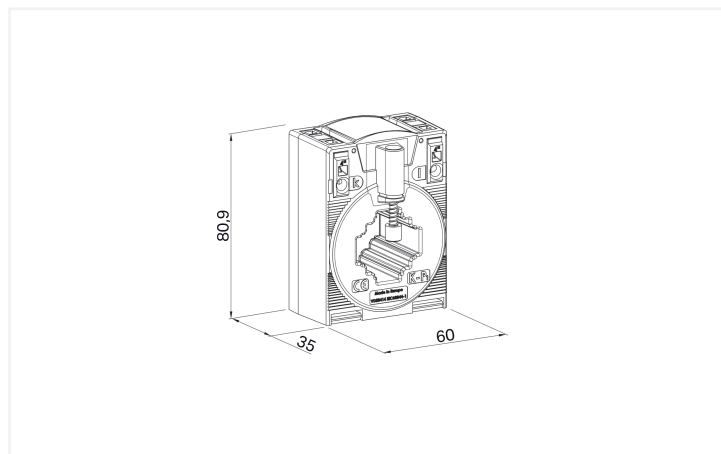

Dimensions in mm

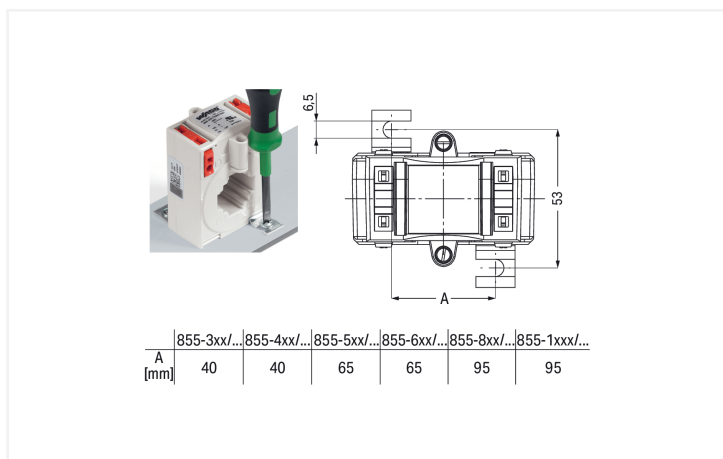

Dimensions in mm

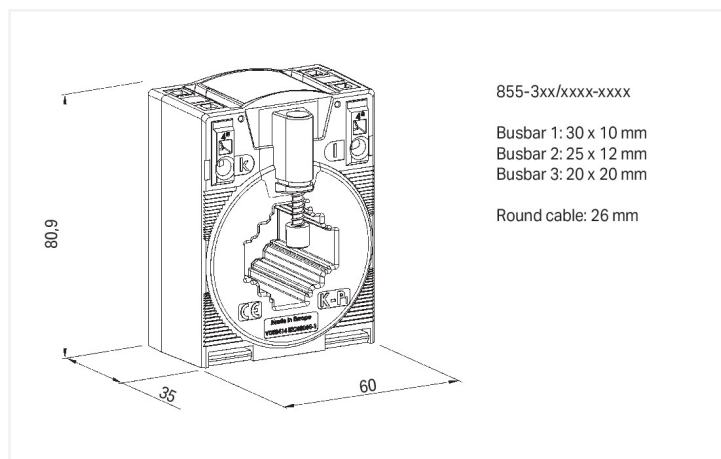

Short description:

WAGO's plug-in current transformers (855 Series) are inductive, single-conductor current transformers. Due to the measurement principle used, these current transformers are exclusively designed for AC network applications.

Features:

- Screwless CAGE CLAMP® connection technology
- Several mounting options available
- Vibration- and shock-resistant
- High mechanical retention forces
- High current-carrying capacity
- Continuous overload of 120 % the nominal primary current
- Low-voltage current transformer for operating voltages up to max. 1.2 kV
- For 690 V power networks
- UL recognized components

Technical data

Input

Measured variable	Current
-------------------	---------

Input – current transformer

Rated continuous thermal current I_{cth}	$1.2 \times I_N$
Rated short-time thermal current I_{th}	$60 \times I_N / 1 \text{ s}$ (max. 100 kA / 1 s)
Overcurrent limiting factor	FS5 / FS10 (type dependent; see type plate inscription)
Rated frequency	50 ... 60 Hz
Primary rated current	60 A

Output – current transformer

Secondary rated current	1 A
Rated power S_r	1.25 VA

Measurement Error

Accuracy class	1
----------------	---

Safety and protection

Test voltage	6 kVAC; 50 Hz; 1 min
Highest voltage for equipment U_m	1.2 kV _{rms} AC

Connection Data

Feedthrough for measurement conductor	Ø 26 mm
---------------------------------------	---------

Connection 1

Connection technology	CAGE CLAMP®
Strip length	9 ... 10 mm / 0.35 ... 0.39 inches
Solid conductor	0.08 ... 4 mm ² / 28 ... 12 AWG
Fine-stranded conductor	0.08 ... 4 mm ² / 28 ... 12 AWG

Physical data

Width	60 mm / 2.362 inches
Height	80.9 mm / 3.185 inches
Depth	52 mm / 2.047 inches

Mechanical data

Mounting type	Closed current transformer Installation on mounting plate Mounting on DIN-rail via DIN-rail adapter Installation on round cable
---------------	--

Material data

Insulation class	E
Weight	230 g

Environmental requirements

Ambient temperature (operation)	-5 ... +50 °C
Ambient temperature (storage)	-25 ... +70 °C
Operating altitude (max.)	1000 m

Standards and Specifications

Conformity marking	CE
Standards/specifications	EN 61869-1 EN 61869-2 UL: E356480

Commercial data

PU (SPU)	1 pcs
Packaging type	Box
Country of origin	HU
Customs tariff number	85043129900

Product Classification

UNSPSC	39121032
eCl@ss 10.0	27-21-09-02
eCl@ss 9.0	27-21-09-02
ETIM 9.0	EC002048
ETIM 10.0	EC002048
ECCN	NO US CLASSIFICATION

Environmental Product Compliance

RoHS Compliance Status	Compliant, No Exemption
------------------------	-------------------------

Approvals / Certificates

General approvals



Approval	Standard	Certificate Name
EAC GZO Almaty Standart	TP TC 004/2011	EAC CoC 03082
UL Underwriters Laboratories Inc.	IEEE C57.13	E356480

Declarations of conformity and manufacturer's declarations

Approval	Standard	Certificate Name
EU-Declaration of Conformity WAGO GmbH & Co. KG	-	-
UK-Declaration of Conformity WAGO GmbH & Co. KG	-	-

Downloads

Environmental Product Compliance

Compliance Search	
Environmental Product Compliance 855-301/060-101	↓

Documentation

Bid Text			
855-301/060-101	05.02.2015	doc 30.50 KB	↓
855-301/060-101	19.02.2019	xml 4.96 KB	↓

Instruction Leaflet		
Aufsteck-Stromwandler	pdf 1438.11 KB	↓

CAD/CAE-Data

CAD data	
2D/3D Models 855-301/060-101	↓

CAE data	
EPLAN Data Portal 855-301/060-101	↓
WSCAD Universe 855-301/060-101	↓
ZUKEN Portal 855-301/060-101	↓

1 Compatible Products

1.1 Optional Accessories

1.1.1 Installation

1.1.1.1 Current transformer terminal block



Item No.: 2007-8876
Compact terminal block; for 3-phase current transformer circuit; 6,00 mm²; multicoloured



Item No.: 2007-8873
Compact terminal block; for current and voltage transformers; 6,00 mm²; multicoloured



Item No.: 2007-8874
Compact terminal block; for current and voltage transformers; 6,00 mm²; multicoloured



Item No.: 2007-8875
Compact terminal block; for current transformer circuit; 6,00 mm²; multicoloured



Item No.: 2007-8877
Compact terminal block; for current transformer circuit; 6,00 mm²; multicoloured

1.1.2 Mounting adapter

1.1.2.1 DIN-rail adapter



Item No.: 855-9900

Carrier rail adapter

1.1.2.2 Fast connection adapter



Item No.: 855-9910

Quick-mount kit

1.1.3 Signal conditioner

1.1.3.1 Current Signal Conditioner



Item No.: 857-551

Current signal conditioner; Current input signal; Current and voltage output signal; Digital output; Configuration via software; Supply voltage: 24 VDC; 6 mm module width



Item No.: 857-550

Current signal conditioner; Current input signal; Current and voltage output signal; Digital output; Configuration via software; Supply voltage: 24 VDC; 6 mm module width; 2,50 mm²

1.1.3.2 Power Measurement Module



Item No.: 2857-570/024-001

3-Phase Power Measurement Module; 3x277/480 V/1 A; Modbus RTU; Digital output; Configuration via software; Supply voltage: 24 VDC

1.1.4 Tool

1.1.4.1 Operating tool



Item No.: 210-720

Operating tool; Blade: 3.5 x 0.5 mm; with a partially insulated shaft; multicoloured

Installation Notes

Installation

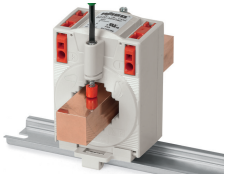

Installation on copper current bar

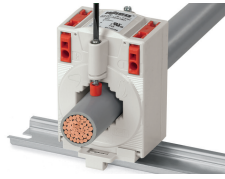

Installation on round cable

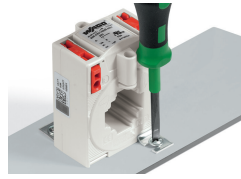

Installation on mounting plate



Mounting on DIN-rail via 855-9900 DIN-Rail Adapter



Snapping onto DIN-rail



Snapping onto DIN-rail

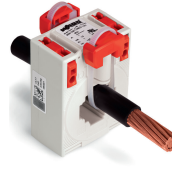

Installation via 855-9910 Quick-Mount Kit

Conductor termination



Conductor termination – screwdriver actuation perpendicular to conductor entry



Conductor termination – screwdriver actuation parallel to conductor entry