

TLE5012BD

GMR-Based Angle Sensor



ISO26262
ready

1 Overview

Features

- Giant Magneto Resistance (GMR)-based principle
- Fully redundant design with two sensor ICs in one package
- Integrated magnetic field sensing for angle measurement
- 360° angle measurement with revolution counter and angle speed measurement
- Two separate highly accurate single bit SD-ADC
- 15 bit representation of absolute angle value on the output (resolution of 0.01°)
- 16 bit representation of sine / cosine values on the interface
- Max. 1.0° angle error over lifetime and temperature-range with activated auto-calibration
- Bi-directional SSC Interface up to 8 Mbit/s
- Supports Safety Integrity Level (SIL) with diagnostic functions and status information
- Interfaces: SSC, PWM, Incremental Interface (IIF), Hall Switch Mode (HSM), Short PWM Code (SPC, based on SENT protocol defined in SAE J2716)
- Output pins can be configured (programmed or pre-configured) as push-pull or open-drain
- Bus mode operation of multiple sensors on one line is possible with SSC or SPC interface
- 0.25 μm CMOS technology
- Automotive qualified: -40°C to 150°C (junction temperature)
- ESD > 4 kV (HBM)
- RoHS compliant (Pb-free package)
- Halogen-free

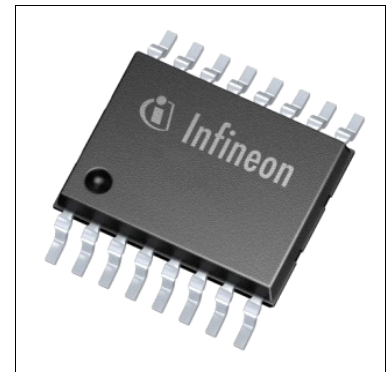

PRO-SIL™ Features

- Test vectors switchable to ADC input (activated via SSC interface)
- Inversion or combination of filter input streams (activated via SSC interface)
- Data transmission check via 8-bit Cyclic Redundancy Check (CRC) for SSC communication and 4-bit CRC nibble for SPC interface
- Built-in Self-test (BIST) routines for ISM, CORDIC, CCU, ADCs run at startup
- Two independent active interfaces possible
- Overvoltage and undervoltage detection

Overview

Potential applications

The TLE5012BD GMR-based angle sensor is designed for angular position sensing in automotive applications such as:

- Electrical commutated motor (e.g. used in Electric Power Steering (EPS))
- Steering angle measurements
- General angular sensing

Product validation

Qualified for automotive applications. Product validation according to AEC-Q100.

About this document

This document is an addendum to the TLE5012B datasheet and describes the TLE5012BD dual die angle sensor. For all parameters which are not specified here, the TLE5012B datasheet is valid.

Description

The TLE5012BD is a 360° angle sensor that detects the orientation of a magnetic field. This is achieved by measuring sine and cosine angle components with monolithic integrated Giant Magneto Resistance (iGMR) elements. These raw signals (sine and cosine) are digitally processed internally to calculate the angle orientation of the magnetic field (magnet).

The TLE5012BD is a pre-calibrated sensor. The calibration parameters are stored in laser fuses. At start-up the values of the fuses are written into flip-flops, where these values can be changed by the application-specific parameters. Further precision of the angle measurement over a wide temperature range and a long lifetime can be improved by enabling an optional internal autocalibration algorithm.

Data communications are accomplished with a bi-directional Synchronous Serial Communication (SSC) that is SPI-compatible. The sensor configuration is stored in registers, which are accessible by the SSC interface.

Additionally four other interfaces are available with the TLE5012BD: Pulse-Width-Modulation (PWM) Protocol, Short-PWM-Code (SPC) Protocol, Hall Switch Mode (HSM) and Incremental Interface (IIF). These interfaces can be used in parallel with SSC or alone. Pre-configured sensor derivatives with different interface settings are available.

Table 1 Derivate ordering codes

Product type	Marking	Ordering code	Package
TLE5012BD E1200	121200	SP001205296	PG-TDSO-16
TLE5012BD E9200	129200	SP001205300	PG-TDSO-16

Table of Contents

1	Overview	1
2	Pin Configuration	4
2.1	Pin Description	4
3	Dual Die Angle Output	5
4	Specification	6
4.1	Absolute Maximum Ratings	6
4.2	Characteristics	6
4.2.1	Input/Output characteristics	6
4.3	Calculation of the Junction Temperature	7
5	Pre-Configured Derivates	9
5.1	IIF-type: E1200	9
5.2	SPC-type: E9200	9
6	Package Information	10
6.1	Package Parameters	10
6.2	Package Outline	10
6.3	Footprint	13
6.4	Packing	13
6.5	Marking	13
7	Revision history	15

Pin Configuration

2 Pin Configuration

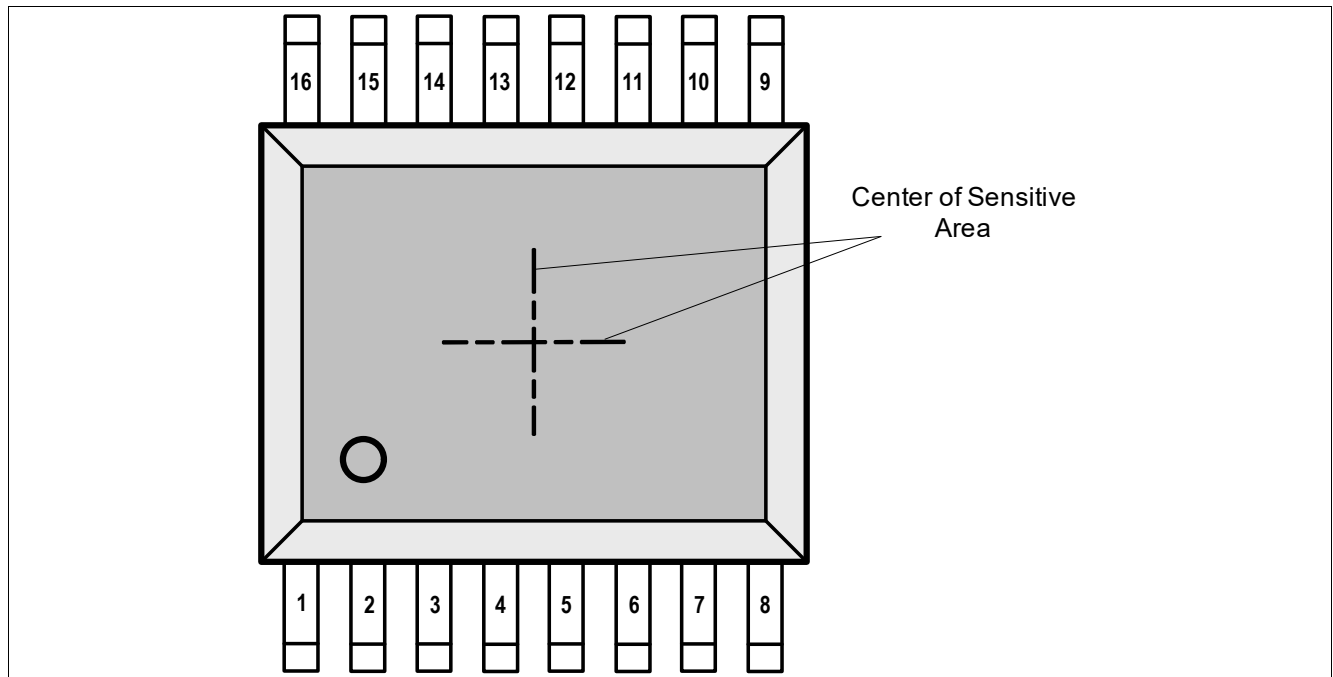

Figure 1 Pin configuration (top view)

2.1 Pin Description

Table 2 Pin Description

Pin No.	Symbol	In/Out	Function
1	IFC1 (CLK / IIF_IDX / HS3)	I/O	Die 1 Interface C: External Clock ¹ / IIF Index / Hall Switch Signal 3
2	SCK1	I	Die 1 SSC Clock
3	CSQ1	I	Die 1 SSC Chip Select
4	DATA1	I/O	Die 1 SSC Data
5	DATA2	I/O	Die 2 SSC Data
6	CSQ2	I	Die 2 SSC Chip Select
7	SCK2	I	Die 2 SSC Clock
8	IFC2 (CLK / IIF_IDX / HS3)	I/O	Die 2 Interface C: External Clock ¹ / IIF Index / Hall Switch Signal 3
9	IFB2 (IIF_B / HS2)	O	Die 2 Interface B: IIF Phase B / Hall Switch Signal 2
10	GND2	-	Die 2 Ground
11	VDD2	-	Die 2 Supply Voltage

Dual Die Angle Output

Table 2 Pin Description (cont'd)

Pin No.	Symbol	In/Out	Function
12	IFA2 (IIF_A / HS1 / PWM / SPC)	O	Die 2 Interface A: IIF Phase A / Hall Switch Signal 1 / PWM / SPC output
13	IFA1 (IIF_A / HS1 / PWM / SPC)	O	Die 1 Interface A: IIF Phase A / Hall Switch Signal 1 / PWM / SPC output
14	VDD1	-	Die 1 Supply Voltage
15	GND1	-	Die 1 Ground
16	IFB1 (IIF_B / HS2)	O	Die 1 Interface B: IIF Phase B / Hall Switch Signal 2

1) External clock feature is not available in IIF or HSM interface mode

3 Dual Die Angle Output

The bottom sensor element of the TLE5012BD is flipped relative to the orientation of the top sensor element. Therefore the rotation direction sensed by the bottom element is opposite to the top element. This is advantageous for safety critical applications, as the two sensor elements do generally not output the same angle. **Figure 2** shows the output of the two sensor ICs for a given external magnetic field orientation.

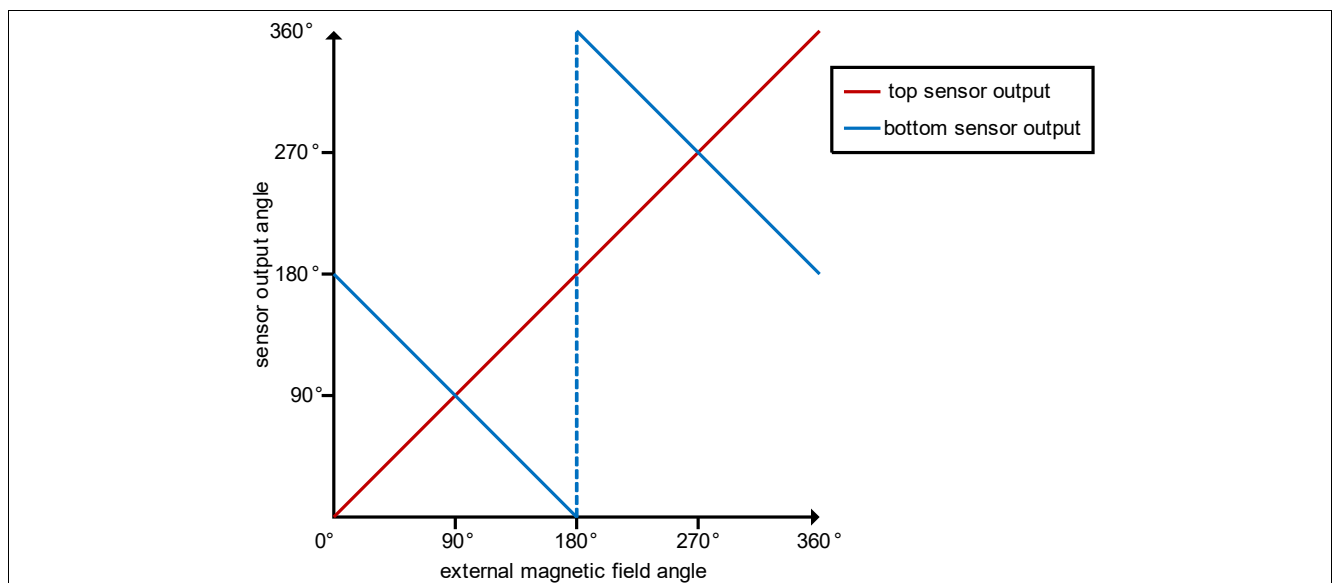

Figure 2 Dual die angle output

For applications where an identical angle output of both ICs is desired, the rotation direction and angle offset of one sensor IC can be reconfigured by changing the settings in the ANG_BASE and ANG_DIR registers via SSC interface.

Specification

4 Specification

4.1 Absolute Maximum Ratings

Table 3 Absolute maximum ratings

Parameter	Symbol	Values			Unit	Note or Test Condition
		Min.	Typ.	Max.		
Ambient temperature	T_A	-40		125	°C	qualification acc. to AEC Q100 grade 1
Junction temperature	T_J	-40		150	°C	
				150	°C	For 1000 h, not additive

Attention: Stresses above the max. values listed here may cause permanent damage to the device. Exposure to absolute maximum rating conditions for extended periods may affect device reliability. Maximum ratings are absolute ratings; exceeding only one of these values may cause irreversible damage to the device.

Table 4 ESD protection

Parameter	Symbol	Values		Unit	Notes
		Min.	Max.		
ESD voltage	V_{HBM}		±4.0	kV	¹⁾ ground pins connected
	V_{HBM}		±2.0	kV	¹⁾
	V_{CDM}		±0.5	kV	²⁾
	V_{CDM}		±0.75	kV	²⁾ for corner pins

1) Human Body Model (HBM) according to ANSI/ESDA/JEDEC JS-001

2) Charged Device Model (CDM) according to JESD22-C101

4.2 Characteristics

4.2.1 Input/Output characteristics

The indicated parameters apply to the full operating range, unless otherwise specified. The typical values correspond to a supply voltage $V_{DD} = 5.0\text{ V}$ and 25°C , unless individually specified. All other values correspond to $-40^\circ\text{C} < T_J < 150^\circ\text{C}$.

Table 5 Electrical parameters for $4.5\text{ V} < V_{DD} < 5.5\text{ V}$

Parameter	Symbol	Values			Unit	Note or Test Condition
		Min.	Typ.	Max.		
Input signal low-level	V_{L5}			$0.3 V_{DD}$	V	
Input signal high level	V_{H5}	$0.7 V_{DD}$			V	

Specification

Table 5 Electrical parameters for 4.5 V < V_{DD} < 5.5 V (cont'd)

Parameter	Symbol	Values			Unit	Note or Test Condition
		Min.	Typ.	Max.		
Output signal low-level	V _{OL5}			1	V	DATA; I _Q = -25 mA (PAD_DRV='0x'), I _Q = -5 mA (PAD_DRV='10'), I _Q = -0.4 mA (PAD_DRV='11')
				1	V	IFA,B,C; I _Q = -15 mA (PAD_DRV='0x'), I _Q = -5 mA (PAD_DRV='1x')
Pull-up current ¹⁾	I _{PU}	-10		-225	μA	CSQ
			-10		-150	μA
Pull-down current ²⁾	I _{PD}	10		225	μA	SCK
			10		150	μA

- 1) Internal pull-ups on CSQ and DATA pin are always enabled.
- 2) Internal pull-downs on IFA, IFB and IFC are enabled during startup and in open-drain mode, internal pull-down on SCK is always enabled.

Table 6 Electrical parameters for 3.0 V < V_{DD} < 3.6 V

Parameter	Symbol	Values			Unit	Note or Test Condition
		Min.	Typ.	Max.		
Input signal low-level	V _{L3}			0.3 V _{DD}	V	
Input signal high level	V _{H3}	0.7 V _{DD}			V	DATA,SCK,CSQ,IFA,IFB
		0.8 V _{DD}			V	IFC
Output signal low-level	V _{OL3}			0.9	V	DATA; I _Q = -15 mA (PAD_DRV='0x'), I _Q = -3 mA (PAD_DRV='10'), I _Q = -0.24 mA (PAD_DRV='11')
				0.9	V	IFA,IFB; I _Q = - 10 mA (PAD_DRV='0x'), I _Q = -3 mA (PAD_DRV='1x')
Pull-up current ¹⁾	I _{PU}	-3		-225	μA	CSQ
			-3		-150	μA
Pull-down current ²⁾	I _{PD}	3		225	μA	SCK
			3		150	μA

- 1) Internal pull-ups on CSQ and DATA pin are always enabled.
- 2) Internal pull-downs on IFA, IFB and IFC are enabled during startup and in open-drain mode, internal pull-down on SCK is always enabled.

4.3 Calculation of the Junction Temperature

The total power dissipation P_{TOT} of the chips leads to self-heating, which increases the junction temperature T_J above the ambient temperature.

Specification

The power multiplied by the total thermal resistance R_{thJA} (junction to ambient) yields the junction temperature. R_{thJA} is the sum of the two components Junction to Case and Case to Ambient.

$$R_{thJA} = R_{thJC} + R_{thCA} \quad (4.1)$$

$$T_J = T_A + \Delta T$$

$$\Delta T = R_{thJA} \times P_{TOT} = R_{thJA} \times (V_{DD} \times 2I_{DD} + \sum_Q V_Q \times 2I_Q) \quad (I_{DD}, I_Q > 0, \text{ if direction is into IC})$$

Factors of 2 in the calculation account for the two sensor ICs in the TLE5012BD. Example (assuming no load on V_{out}).

$$V_{DD} = 5V \quad (4.2)$$

$$2I_{DD} = 28mA$$

$$\Delta T = 120 \left[\frac{K}{W} \right] \times (5[V] \times 0.028[A] + 0[V \cdot A]) = 16.8K$$

For molded sensors, the calculation with R_{thJC} is more appropriate.

5 Pre-Configured Derivates

Derivates of the TLE5012BD are available with different pre-configured register settings for specific applications. The configuration of all derivates can be changed via SSC interface. A detailed table of settings of the derivates can be found in the latest TLE5012B Register Setting User Manual.

5.1 IIF-type: E1200

The TLE5012BD-E1200 is preconfigured for Incremental Interface and fast angle update rate (42.7 μ s). It is most suitable for BLDC motor commutation.

- Autocalibration mode 1 enabled.
- Prediction disabled.
- Hysteresis is set to 0.625°.
- 12bit mode, one count per 0.088° angle step.
- Incremental Interface A/B mode.

5.2 SPC-type: E9200

The TLE5012BD-E9200 is preconfigured for Short-PWM-Code interface. It is most suitable for steering angle and actuator position sensing.

- Angle update time is 85.4 μ s.
- Autocalibration, Prediction, and Hysteresis are disabled.
- SPC unit time is 3 μ s.
- SPC interface is set to open-drain output.

Package Information

6 Package Information

6.1 Package Parameters

Table 7 Package Parameters

Parameter	Symbol	Limit Values			Unit	Notes
		Min.	Typ	Max.		
Thermal resistance ¹⁾	R_{thJA}		120	140	K/W	Junction to air ²⁾
	R_{thJC}			35	K/W	Junction to case
	R_{thJL}			70	K/W	Junction to lead
Moisture Sensitivity Level		MSL 3				260°C
Lead Frame		Cu				
Plating		Sn 100%				> 7 μ m

1) R_{th} values only valid for both dies supplied with V_{DD}

2) according to Jedec JESD51-7

6.2 Package Outline

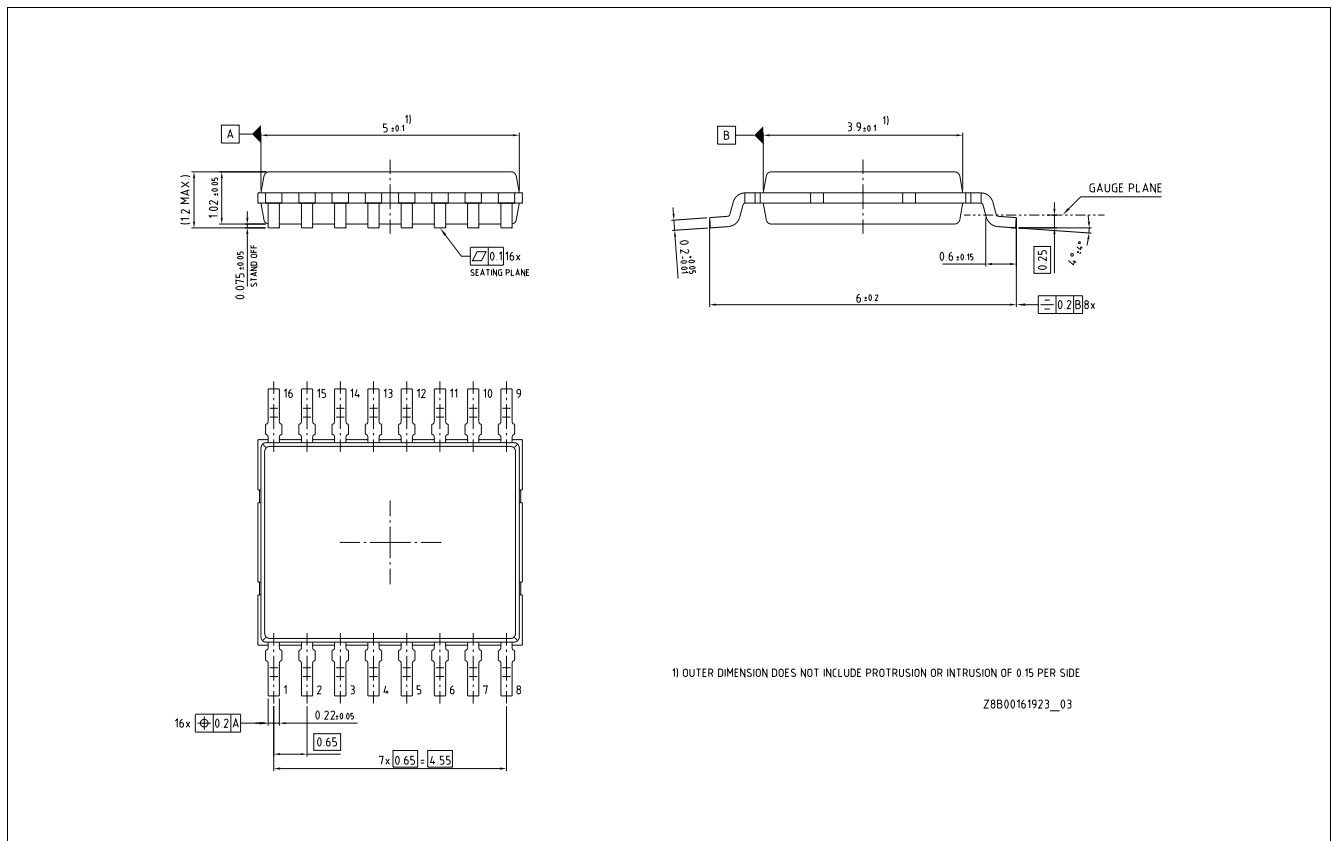

Figure 3 PG-TDSO-16 package dimension

Package Information

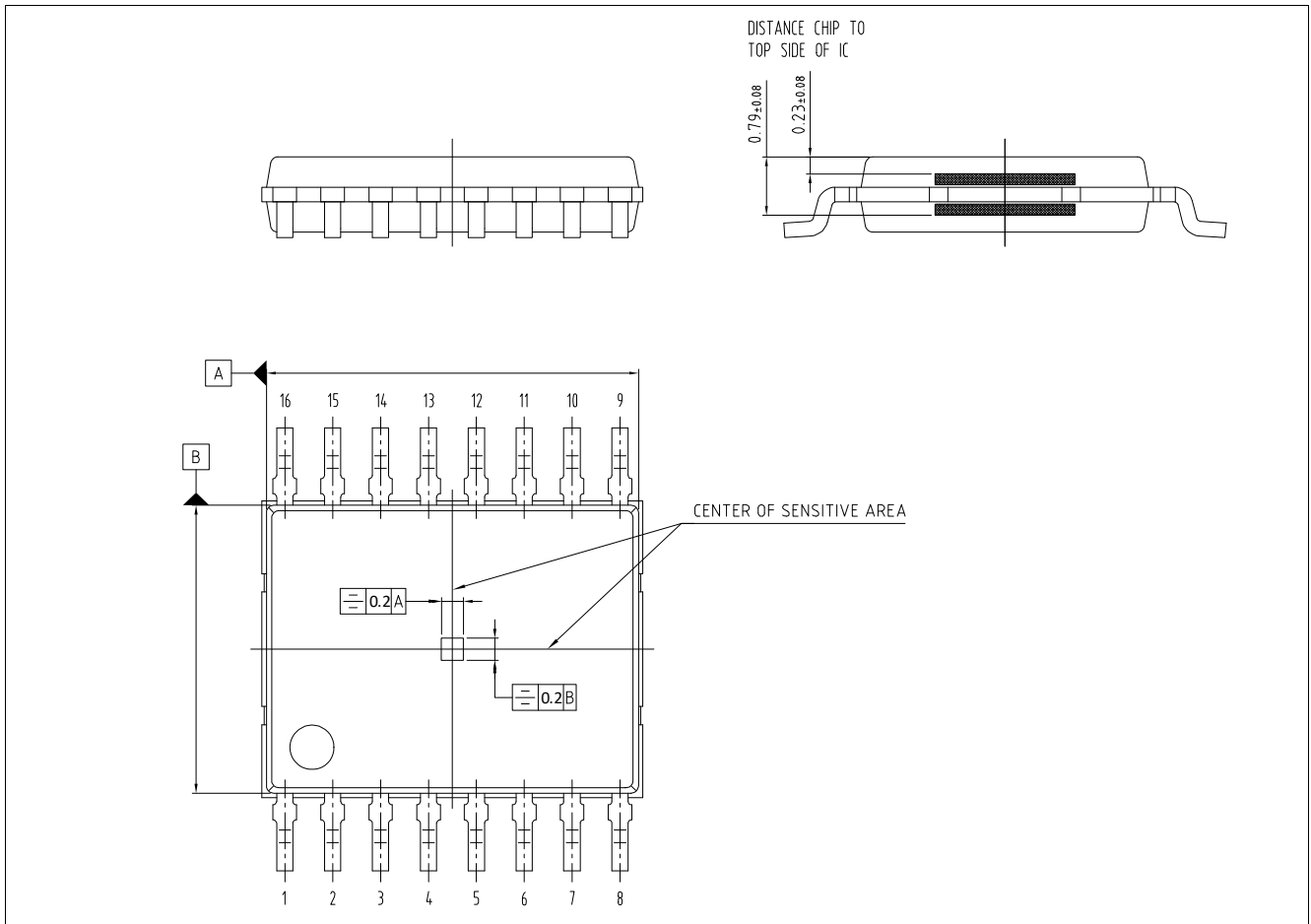

Figure 4 Position of sensing element, reference to package

Package Information

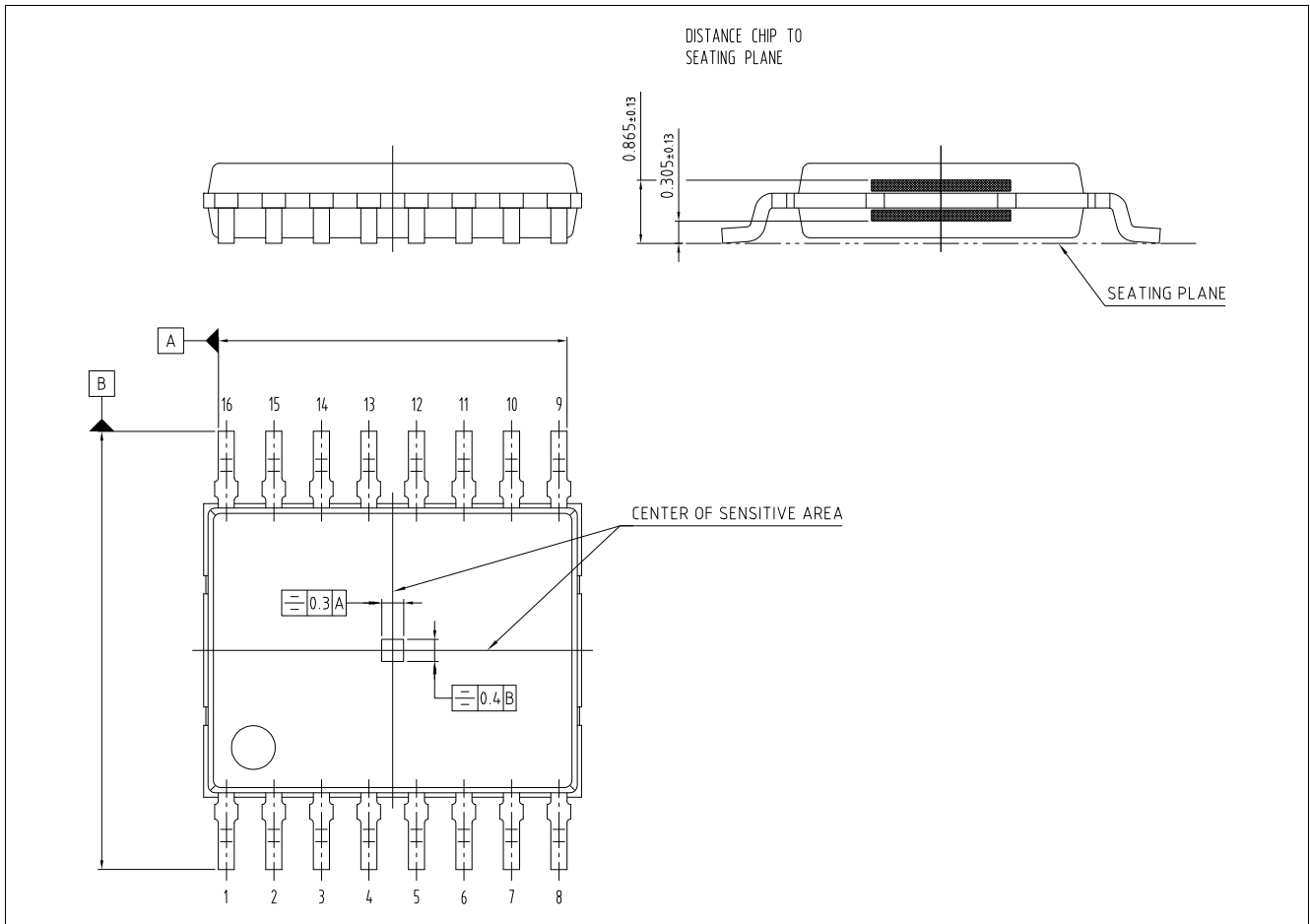

Figure 5 Position of sensing element, reference to lead frame

Table 8 Sensor IC placement tolerances in package

Parameter	Values		Unit	Notes
	Min.	Max.		
position eccentricity	-100	100	μm	in X- and Y-direction, reference to package
position eccentricity	-150	150	μm	in X-direction, reference to lead frame
position eccentricity	-200	200	μm	in Y-direction, reference to lead frame
rotation	-3	3	$^{\circ}$	affects zero position offset of sensor
tilt	-3	3	$^{\circ}$	

Package Information

6.3 Footprint

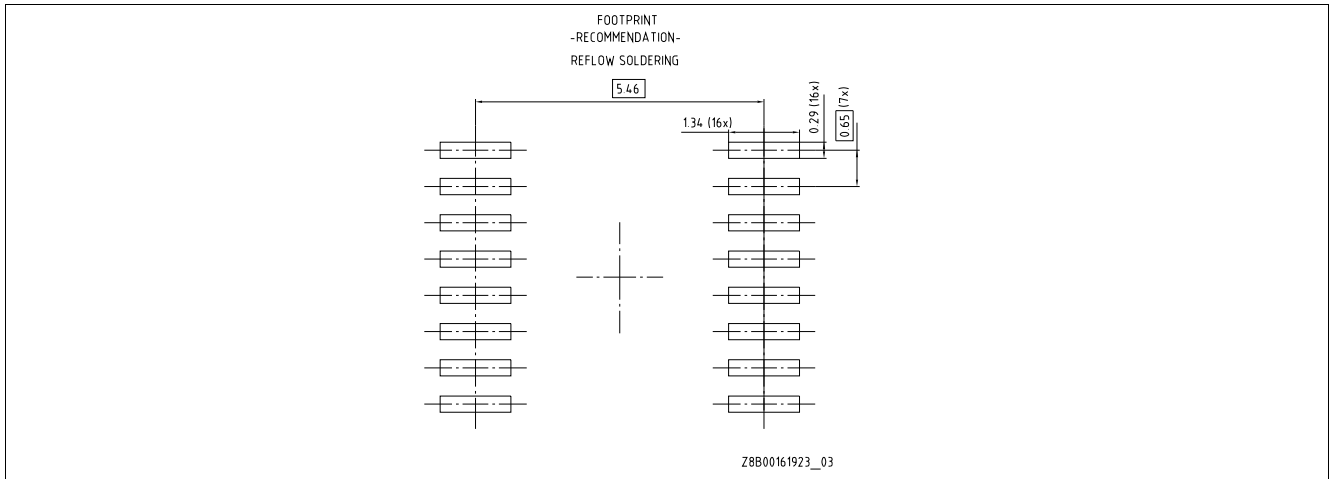

Figure 6 Footprint of PG-TDSO-16

6.4 Packing

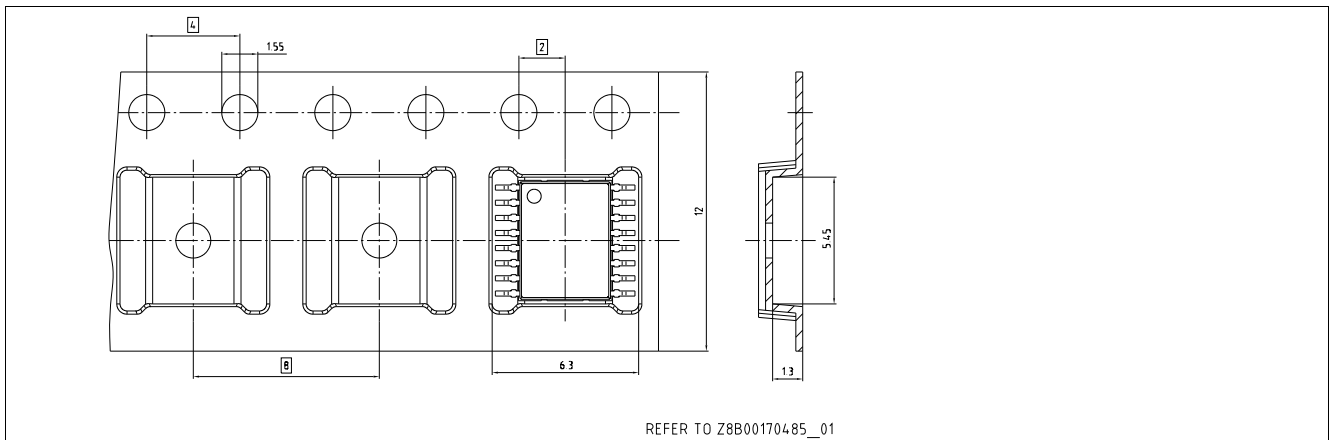

Figure 7 Tape and Reel

6.5 Marking

The device is marked on the frontside with a date code, the device type and a lot code. On the backside is a 8 x 18 data matrix code.

Position	Marking	Description
1st Line	Gxxxx	G = green, 4-digit = date code
2nd Line	12x200	Type (6 digits), See ordering Table 1
3rd Line	xxx	Lot code (3 digits)

Note: For processing recommendations, please refer to Infineon's Notes on processing

Package Information

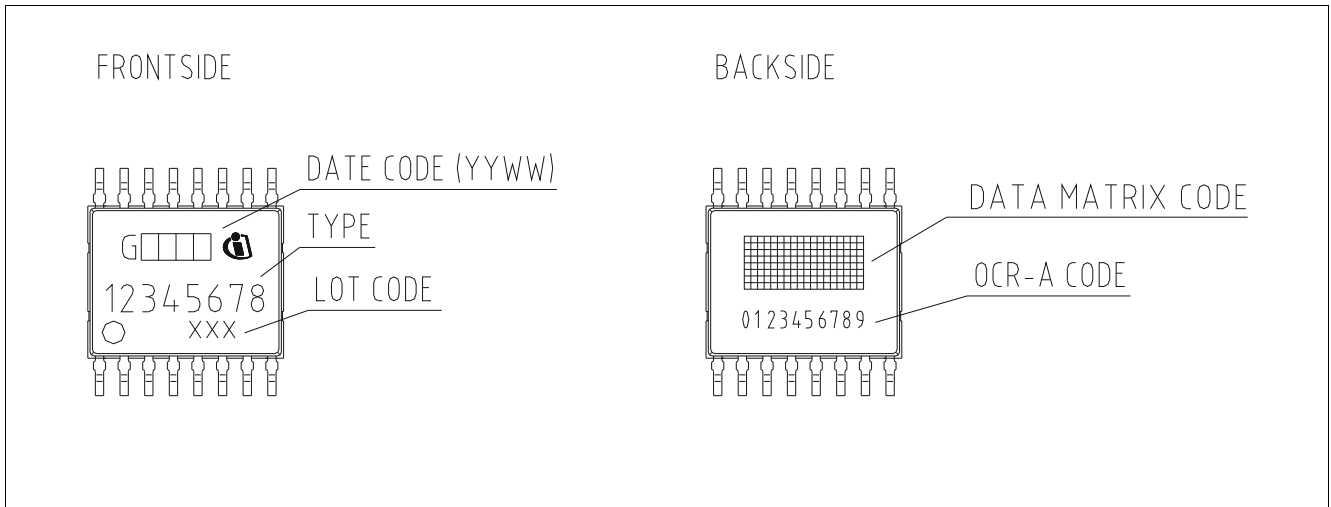

Figure 8 Marking

Revision history

7 Revision history

Revision	Date	Changes
Rev. 1.3	2019-02-05	New Template/New Logo Update Electrical parameters: V_{H3} for IFC pin

Trademarks

All referenced product or service names and trademarks are the property of their respective owners.

Edition 2019-02-05

Published by

Infineon Technologies AG

81726 Munich, Germany

© 2019 Infineon Technologies AG.

All Rights Reserved.

Do you have a question about any aspect of this document?

Email: erratum@infineon.com

Document reference

Doc_Number

IMPORTANT NOTICE

The information given in this document shall in no event be regarded as a guarantee of conditions or characteristics ("Beschaffheitsgarantie").

With respect to any examples, hints or any typical values stated herein and/or any information regarding the application of the product, Infineon Technologies hereby disclaims any and all warranties and liabilities of any kind, including without limitation warranties of non-infringement of intellectual property rights of any third party.

In addition, any information given in this document is subject to customer's compliance with its obligations stated in this document and any applicable legal requirements, norms and standards concerning customer's products and any use of the product of Infineon Technologies in customer's applications.

The data contained in this document is exclusively intended for technically trained staff. It is the responsibility of customer's technical departments to evaluate the suitability of the product for the intended application and the completeness of the product information given in this document with respect to such application.

For further information on technology, delivery terms and conditions and prices, please contact the nearest Infineon Technologies Office (www.infineon.com).

WARNINGS

Due to technical requirements products may contain dangerous substances. For information on the types in question please contact your nearest Infineon Technologies office.

Except as otherwise explicitly approved by Infineon Technologies in a written document signed by authorized representatives of Infineon Technologies, Infineon Technologies' products may not be used in any applications where a failure of the product or any consequences of the use thereof can reasonably be expected to result in personal injury.