

## NCV890203 Evaluation Board User's Manual



ON Semiconductor®

<http://onsemi.com>

### EVAL BOARD USER'S MANUAL

#### Description

The NCV890203 is a fixed-frequency, monolithic, Buck switching regulator intended for Automotive, battery-connected applications that must operate with up to a 36 V input supply. The regulator is suitable for systems with low noise and small form factor requirements often encountered in automotive driver information systems. The NCV890203 is capable of converting the typical 4.5 V to 18 V automotive input voltage range to outputs as low as 3.3 V at a constant switching frequency above the sensitive AM band, eliminating the need for costly filters and EMI countermeasures. A Reset pin signals when the output is in regulation, and a pin is provided to adjust the delay before the RSTB signal goes high. The NCV890203 also provides several protection features expected in Automotive power supply systems such as current limit, short circuit protection, and thermal shutdown. In addition, the high switching frequency produces low output voltage ripple even when using small inductor values and an all-ceramic output filter capacitor – forming a space-efficient switching regulator solution.

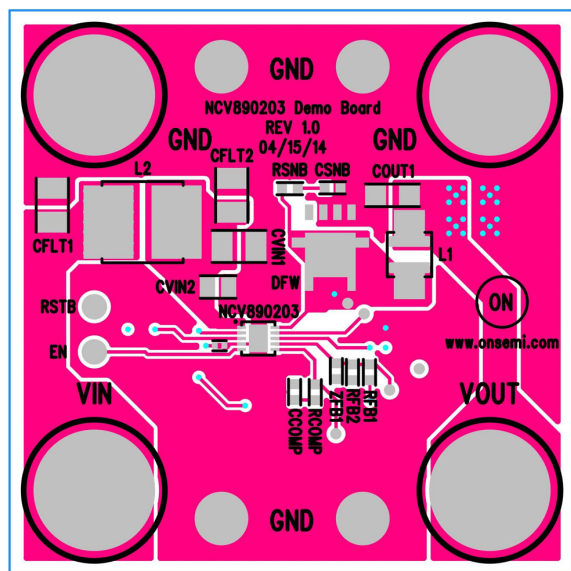

Figure 1. NCV890203 Evaluation Board

#### Key Features

- Internal N-channel Power Switch
- Low  $V_{IN}$  Operation Down to 4.5 V
- High  $V_{IN}$  Operation to 36 V
- Withstands Load Dump to 40 V
- 2 MHz Free-running Switching Frequency
- Reset with Adjustable Delay
- Logic level Enable Input Can be Directly Tied to Battery
- 2.0 A (min) Cycle-by-Cycle Peak Current Limit
- Short Circuit Protection enhanced by Frequency Foldback
- $\pm 1.75\%$  Output Voltage Tolerance
- Output Voltage Adjustable Down to 0.8 V
- 1.4 Millisecond Internal Soft-Start
- Thermal Shutdown (TSD)
- Low Shutdown Current
- NCV Prefix for Automotive and Other Applications Requiring Unique Site and Control Change Requirements; AEC-Q100 Qualified and PPAP Capable
- Wettable Flanks DFN (Pin Edge Plating)
- These Devices are Pb-Free and are RoHS Compliant

#### Typical Applications

- Audio, Infotainment, Safety – Vision Systems, Instrumentation

# NCV890203GEVB

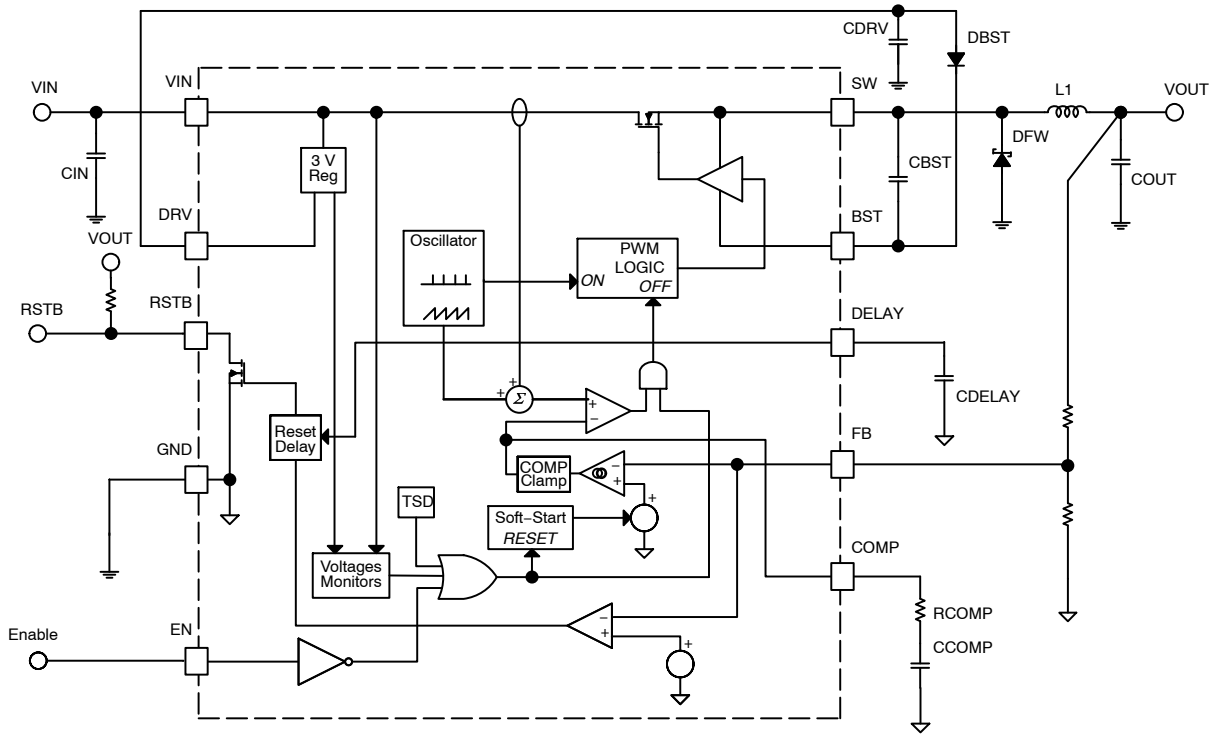

Figure 2. NCV890203 Block Diagram

## TYPICAL APPLICATION

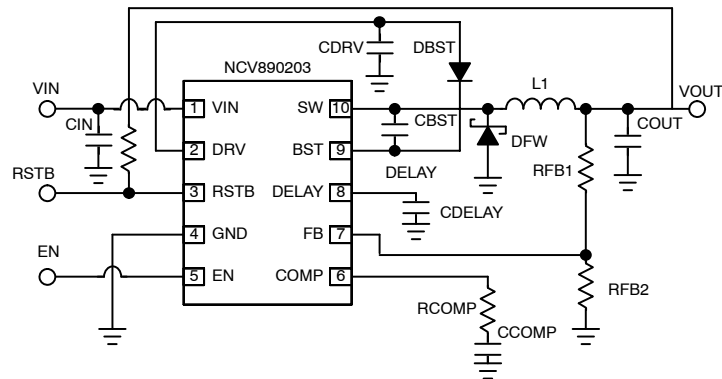

Figure 3. NCV890203 Typical Application

# NCV890203GEVB

**Table 1. EVALUATION BOARD TERMINALS**

Pin Name	Function
VIN	Positive dc Input Voltage
GND	Common dc Return
VOUT	Positive dc Output Voltage
EN	Master Enable Input
RSTB	Reset with Adjustable Delay

**Table 2. ABSOLUTE MAXIMUM RATINGS** (Voltages are with respect to GND)

Rating	Value	Unit
Dc Supply Voltage (VIN, EN)	-0.3 to 40	V
Dc Supply Voltage (RSTB)	-0.3 to 6	V
Storage Temperature Range	-55 to +150	°C

Stresses exceeding those listed in the Maximum Ratings table may damage the device. If any of these limits are exceeded, device functionality should not be assumed, damage may occur and reliability may be affected.

**Table 3. ELECTRICAL CHARACTERISTICS**

Characteristic	Conditions	Typical Value	Unit
<b>REGULATION</b>			
Output Voltage (VOUT)		5.0	V
Line Regulation (VOUT)	$I_{OUT} = 1.0 \text{ A}$	0.1	%
Load Regulation (VOUT)	$V_{IN} = 13.2 \text{ V}$	0.1	%
<b>SWITCHING</b>			
Switching Frequency		2.0	MHz
Soft-start Time		1.4	ms
<b>CURRENT LIMIT</b>			
Peak Current Limit (VOUT)	$EN = 5 \text{ V}$	3.25	A
<b>PROTECTIONS</b>			
Input Undervoltage Lockout (UVLO)	$V_{IN}$ Decreasing	3.4	V
Thermal Shutdown	$T_J$ Rising	170	°C

Product parametric performance is indicated in the Electrical Characteristics for the listed test conditions, unless otherwise noted. Product performance may not be indicated by the Electrical Characteristics if operated under different conditions.

# NCV890203GEVB

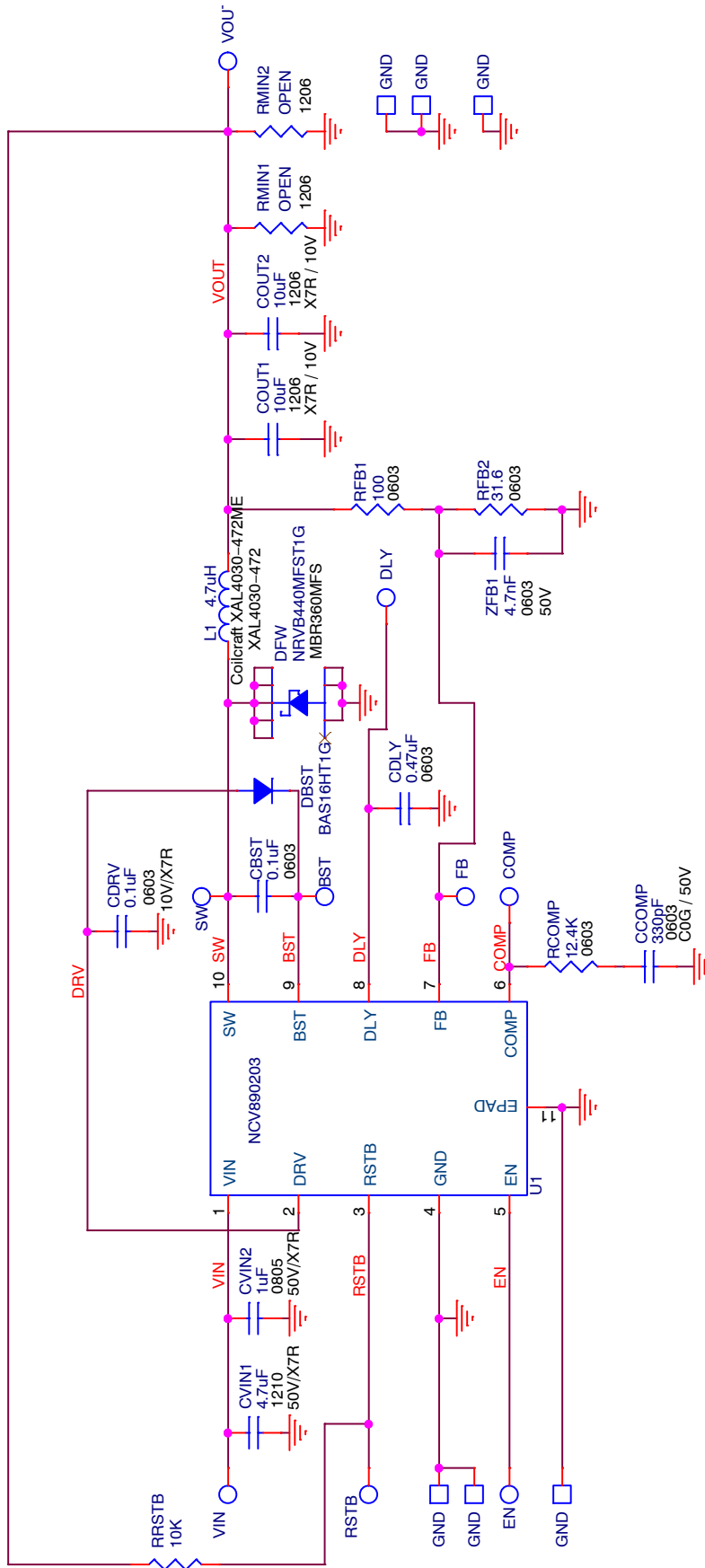

Figure 4. NCV890203GEVB Evaluation Board Schematic

# NCV890203GEVB

## OPERATIONAL GUIDELINES

1. Connect a dc input voltage, within the 6.0 V to 36 V range, between VIN and GND.
2. Connect a dc enable voltage, within the 2.0 V to 36 V range, between EN and GND. This will power up the switcher. The VOUT signal should be 3.3 V.
3. Add a load to VOUT – up to 2.0 A.

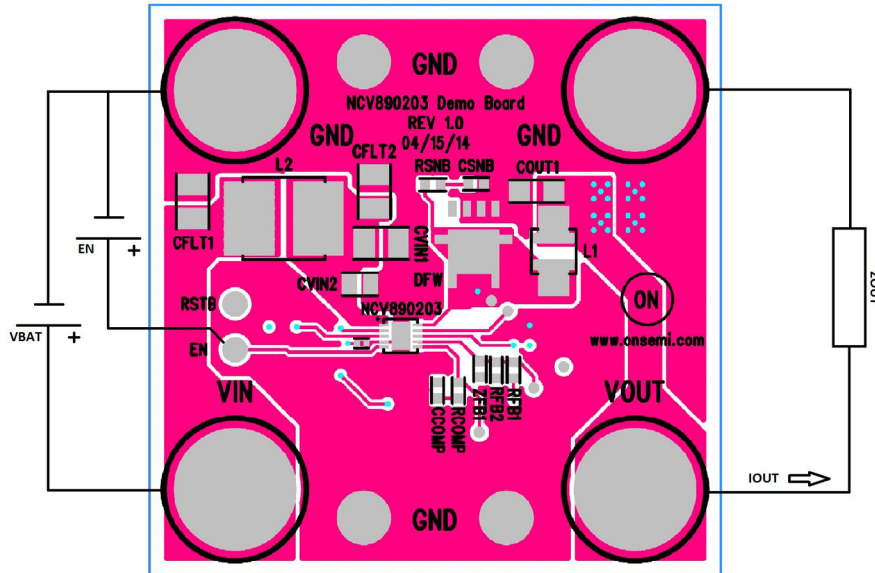
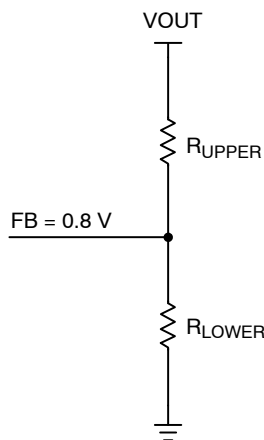

Figure 5. NCV890203 Board Connections

## ADDITIONAL GUIDELINES

### Output Voltage Selection

The voltage output for the switcher is adjustable and can be set with a resistor divider. The FB reference for the switcher is 0.8 V.



Use the following equation:

$$R_{UPPER} = R_{LOWER} \frac{V_{OUT} - V_{FB}}{V_{FB}}$$

Some common setups are listed below:

Desired Output (V)	VREF (V)	R <sub>UPPER</sub> (kΩ, 1%)	R <sub>LOWER</sub> (kΩ, 1%)
1.2	0.8	5.11	10.0
1.5	0.8	8.87	10.0
1.8	0.8	12.7	10.0
2.5	0.8	21.5	10.0
3.3	0.8	31.6	10.0
5.0	0.8	52.3	10.0

### Reset with Adjustable Delay

The RSTB pin is pulled low as long as the voltage on the FB pin is lower than 92% (typical) of the reference voltage (which corresponds to the output voltage being lower than 92% of its regulation level). It is high impedance when the voltage goes above 94% (typical) of the regulation level, after a delay adjusted by the capacitor on the DELAY pin.

The capacitor is held at ground until the output enters regulation: C<sub>DELAY</sub> is then quickly charged to the internal rail voltage (V<sub>RESU</sub>), then discharged by the I<sub>delay</sub> current until its voltage reaches the lower threshold V<sub>DELTH</sub>. Only at this moment the RSTB pin voltage goes high, indicating the end of the Reset condition.

## NCV890203GEVB

A small filtering delay (of duration  $t_{PG}$ ) ensures that the RSTB signal doesn't toggle from high to low in case of high frequency noise when the output is in regulation.

A pull-up resistor is needed on the RSTB pin, as it features an open collector output, capable of sinking 1 mA minimum at 400 mV.

The RSTB pin is also pulled low in case of UVLO ( $V_{IN}$  below the UVLO threshold), TSD (temperature shutdown) or Disable ( $V_{EN}$  below the enable threshold) events.

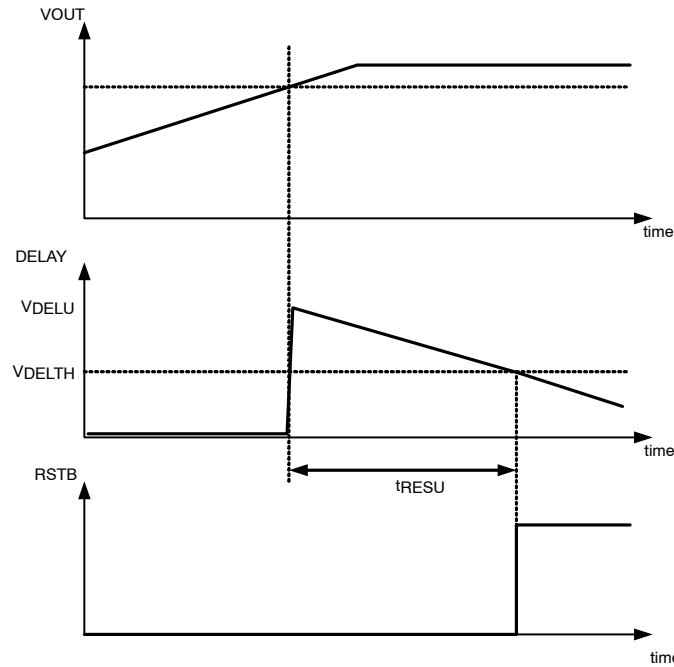

Figure 6. Typical Operation of the Reset with Delay Function

# NCV890203GEVB

## TYPICAL PERFORMANCE

### Efficiency

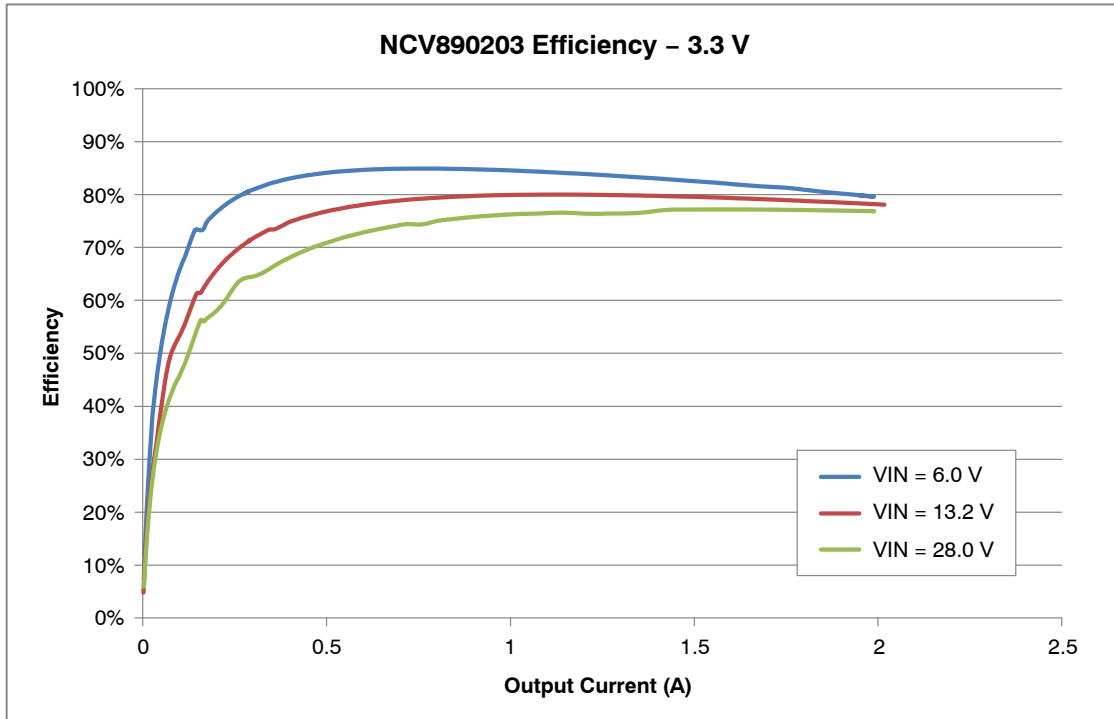

Figure 7. Efficiency with a 3.3 V Output

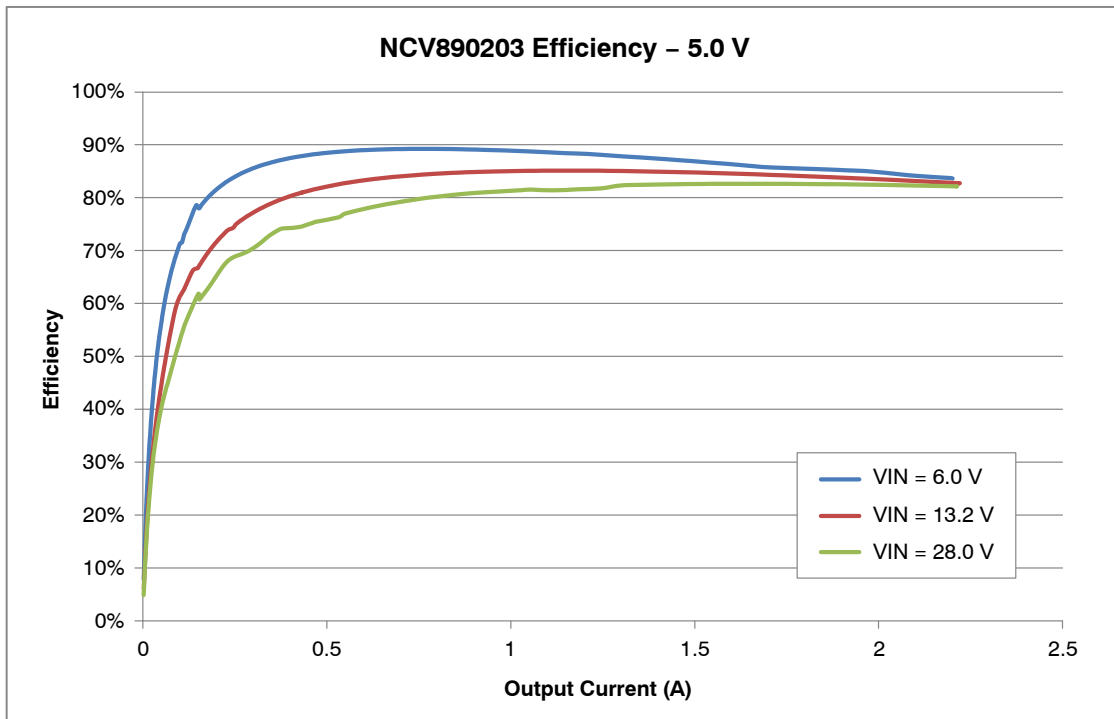

Figure 8. Efficiency with a 5.0 V Output

# NCV890203GEVB

## Line Regulation

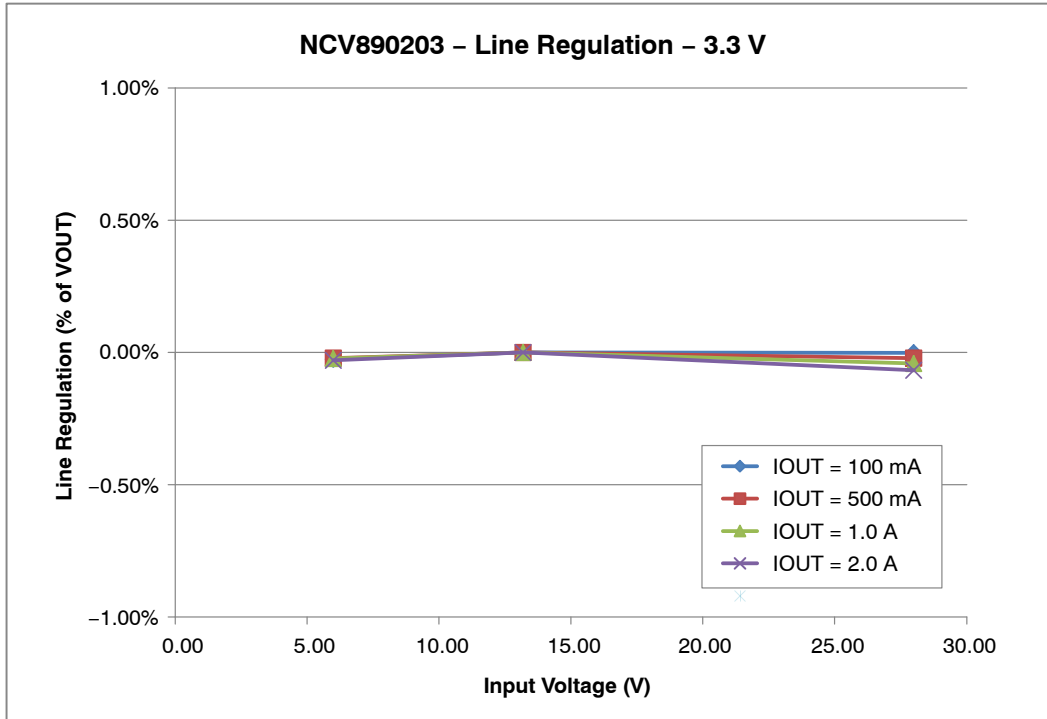

Figure 9. Line Regulation for a 3.3 V Output

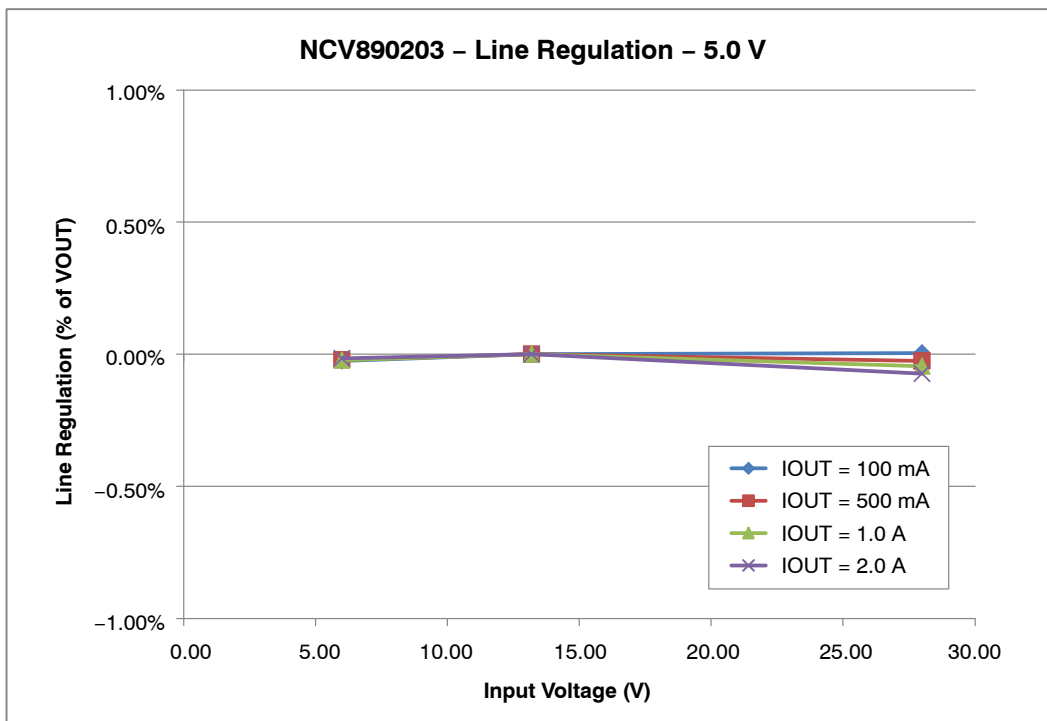

Figure 10. Line Regulation for a 5.0 V Output

# NCV890203GEVB

## Load Regulation

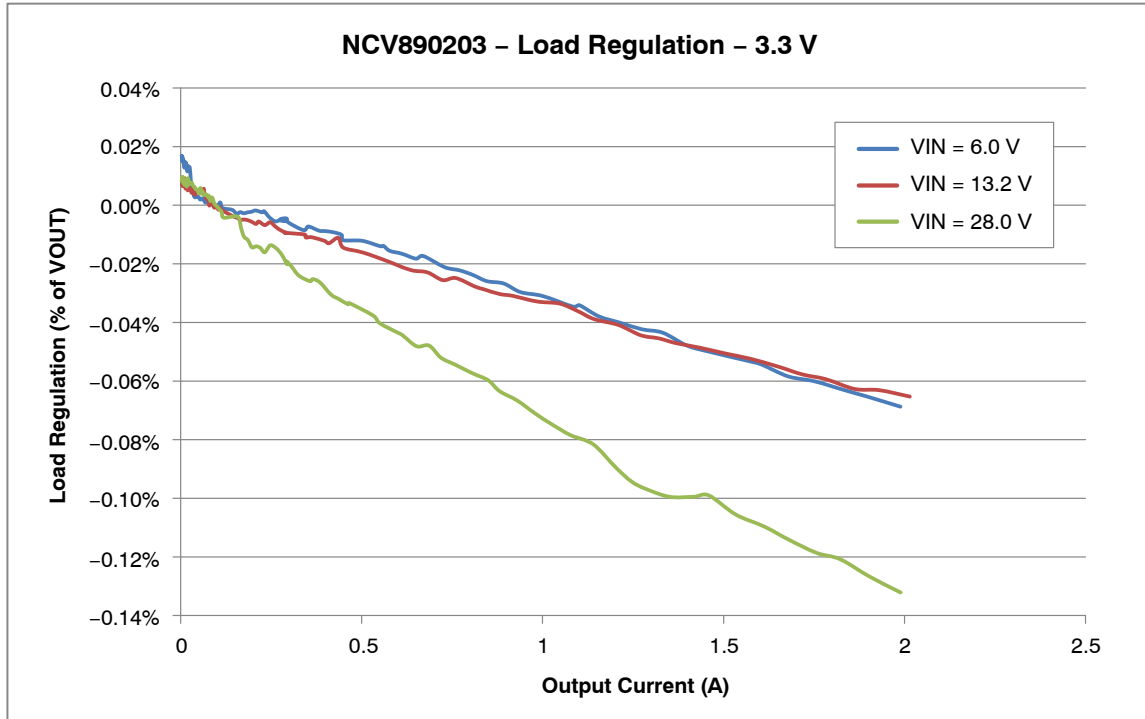

Figure 11. Load Regulation with a 3.3 V Output

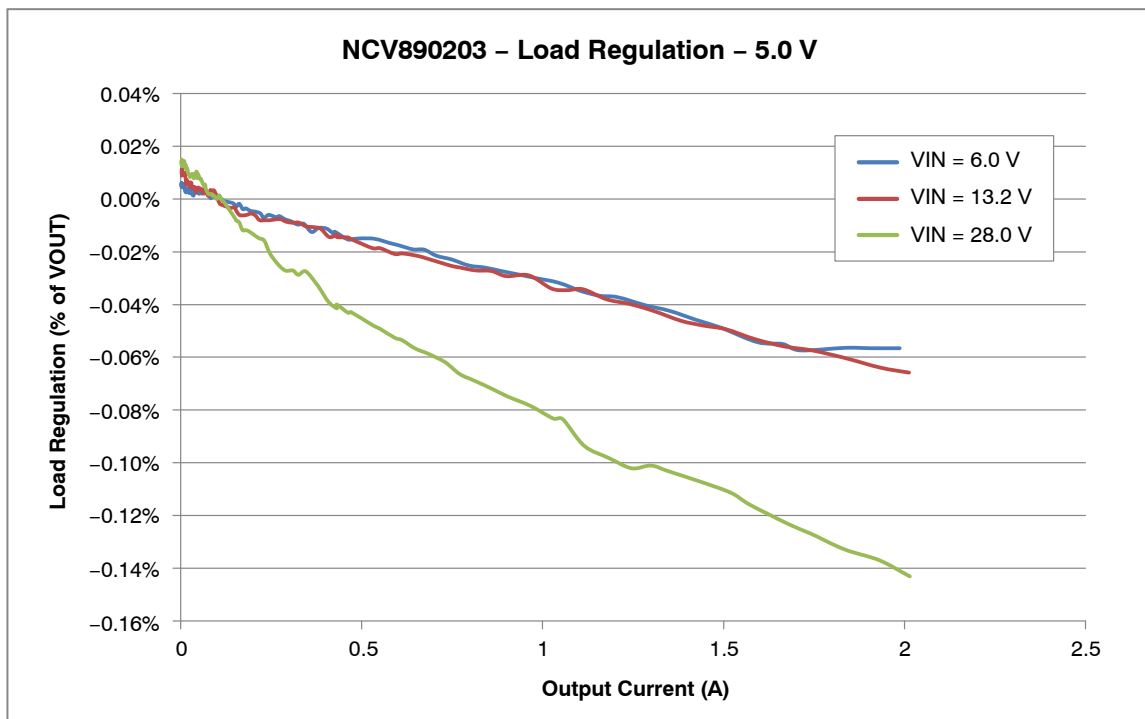

Figure 12. Load Regulation with a 5.0 V Output

# NCV890203GEVB

## SCHEMATIC

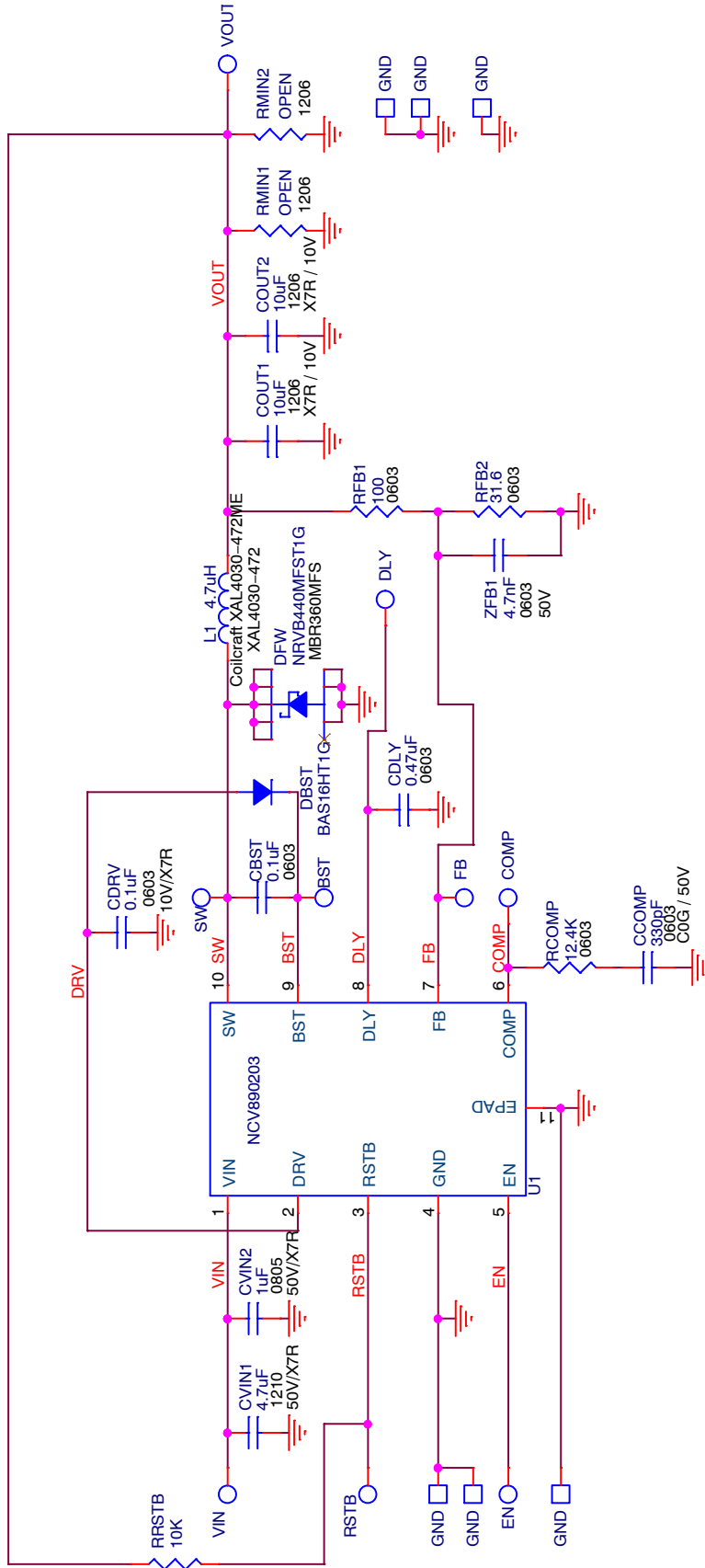

Figure 13. Schematic

# NCV890203GEVB

## PCB LAYOUT

NCV890203 Demo Board Rev. 1 – 04/15/14  
TOP Layer

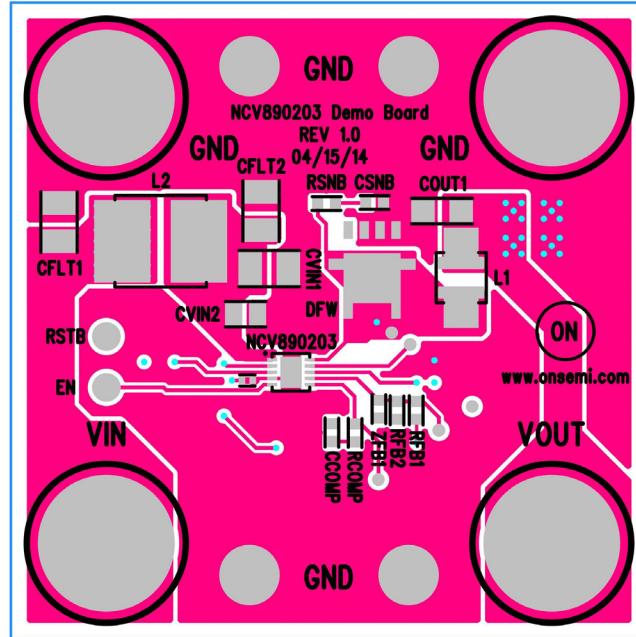

Figure 14. Top View

NCV890203 Demo Board Rev. 1 – 04/15/14  
BOTTOM Layer (mirrored)

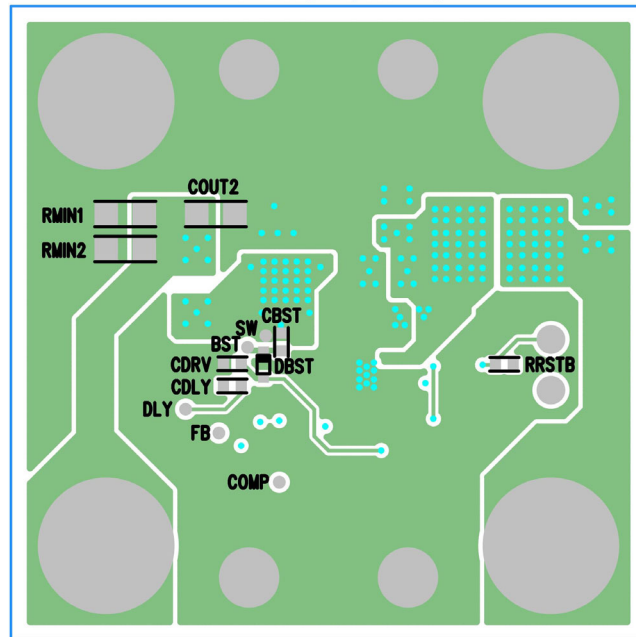

Figure 15. Bottom View

# NCV890203GEVB

## BILL OF MATERIALS

Table 4. BILL OF MATERIALS

Reference Designator(s)	Qty.	Description	Value	Tolerance	Footprint	Manufacturer	Manufacturer's Part Number	Substitution Allowed
CBST, CDRV	2	CAP.10 $\mu$ F 10 V CERAMIC X7R 0603	0.1 $\mu$ F	10%	603	Kemet	C0603C104K8RACTU	Yes
CCOMP	1	CAP CER 330 pF 50 V C0G 0603	330 pF	10%	603	Murata Electronics North America	GCM1885C1H331JA16D	Yes
CDLY	1	CAP CER 0.47 $\mu$ F 25 V 10% X7R 0603	0.47 $\mu$ F	10%	603	Murata Electronics North America	GCM188R71E474KA64D	Yes
CFLT1, CFLT2, CVIN1	3	CAP CER 4.7 $\mu$ F 50 V 10% X7R 1210	4.7 $\mu$ F	10%	1210	Murata Electronics North America	GRM32ER71H475KA88L	Yes
COUT1, COUT2	2	CAP CER 10 $\mu$ F 10 V 10% X7R 1206	10 $\mu$ F	10%	1206	Taiyo Yuden	LMK316AB7106KLHT	Yes
CVIN2	1	CAP CER 1.0 $\mu$ F 50 V X5R 0805	1.0 $\mu$ F	10%	805	Murata Electronics North America	UMK212BJ105KG-T	Yes
DBST	1	DIODE SWITCH 200 mA 75 V SOD323	75 V/0.2 A	N/A	SOD_323	ON Semiconductor	BAS16HT1G	No
DFW	1	DIODE SCHOTTKY 4.0 A 40 V SMB	40 V/4.0 A	N/A	SMB_DIODE	ON Semiconductor	NRVB440MFST1G	No
L1	1	INDUCTOR POWER 4.7 $\mu$ H 4.5 A 20% SMD	4.7 $\mu$ H	4.5A	XAL4030-472	Coilcraft	XAL4030-472ME	No
*L2	1	RES 0.0 $\Omega$ 1/4 W JUMP 1206 SMD	0 $\Omega$	5%	1206	Yageo	RC1206JR-070RL	Yes
RCOMP	1	RES 6.98 k $\Omega$ 1/10 W 1% 0603 SMD	6.98 k $\Omega$	1%	603	Vishay/Dale	CRCW06036K98FKEA	Yes
RFB1	1	RES 100 $\Omega$ 1/10 W 1% 0603 SMD	100 $\Omega$	1%	603	Vishay/Dale	CRCW0603100RFKEA	Yes
RFB2	1	RES 31.6 $\Omega$ 1/10 W 1% 0603 SMD	31.6 $\Omega$	1%	603	Vishay/Dale	CRCW060331R6FKEA	Yes
RRSTB	1	RES 10.0 k $\Omega$ 1/10 W 1% 0603 SMD	10.0 k $\Omega$	1%	603	Vishay/Dale	CRCW060310K0FKEA	Yes
ZFB1	1	CAP CER 4700 PF 50 V 10% X7R 0603	4700 pF	10%	603	Murata Electronics North America	GRM188R71H472KA01D	Yes
CSNB	1		Do Not Populate		603			Yes
RMIN1, RMIN2	2		Do Not Populate		1206			Yes
RSNB	1		Do Not Populate		603			Yes
BST, COMP, DLY, FB, RDEP, RMOD, SW	7	CIRCUIT PIN PRNTD .020"D .425"L	Do Not Populate	N/A	TPA	Mill-Max Manufacturing Corp.	3128-2-00-15-00-00-08-0	Yes
GND1, GND2, VIN, VOUT	4	CONN JACK BANANA UNINS PANEL MOU	N/A	N/A	BANANA	Emerson Network Power Connectivity Solutions	108-0740-001	Yes

# NCV890203GEVB

**Table 4. BILL OF MATERIALS** (continued)

Reference Designator(s)	Qty.	Description	Value	Tolerance	Footprint	Manufacturer	Manufacturer's Part Number	Substitution Allowed
GND3-GND6	4	TERM SOLDER TURRET .219" .109"L	N/A	N/A	TURRET	Mill-Max Manufacturing Corp.	2501-2-00-44-00-00-07-0	Yes
EN, RSTB	2	PIN INBOARD .042" HOLE 1000/PKG	N/A	N/A	TP	Vector Electronics	K24C/M	Yes
NCV890203	1	2.0 A 2 MHz Automotive Buck Switching Regulator	NCV890203	N/A	10PINDFNP5	ON Semiconductor	NCV890203MWTXG	No

\*L2 is a placeholder footprint for an optional input inductor filter component. Boards are shipped with a shorting jumper installed to complete the input path.

NOTE: All devices are RoHS Compliant.

**onsemi**, **Onsemi**, and other names, marks, and brands are registered and/or common law trademarks of Semiconductor Components Industries, LLC dba "**onsemi**" or its affiliates and/or subsidiaries in the United States and/or other countries. **onsemi** owns the rights to a number of patents, trademarks, copyrights, trade secrets, and other intellectual property. A listing of **onsemi**'s product/patent coverage may be accessed at [www.onsemi.com/site/pdf/Patent-Marking.pdf](http://www.onsemi.com/site/pdf/Patent-Marking.pdf). **onsemi** is an Equal Opportunity/Affirmative Action Employer. This literature is subject to all applicable copyright laws and is not for resale in any manner.

The evaluation board/kit (research and development board/kit) (hereinafter the "board") is not a finished product and is not available for sale to consumers. The board is only intended for research, development, demonstration and evaluation purposes and will only be used in laboratory/development areas by persons with an engineering/technical training and familiar with the risks associated with handling electrical/mechanical components, systems and subsystems. This person assumes full responsibility/liability for proper and safe handling. Any other use, resale or redistribution for any other purpose is strictly prohibited.

**THE BOARD IS PROVIDED BY ONSEMI TO YOU "AS IS" AND WITHOUT ANY REPRESENTATIONS OR WARRANTIES WHATSOEVER. WITHOUT LIMITING THE FOREGOING, ONSEMI (AND ITS LICENSORS/SUPPLIERS) HEREBY DISCLAIMS ANY AND ALL REPRESENTATIONS AND WARRANTIES IN RELATION TO THE BOARD, ANY MODIFICATIONS, OR THIS AGREEMENT, WHETHER EXPRESS, IMPLIED, STATUTORY OR OTHERWISE, INCLUDING WITHOUT LIMITATION ANY AND ALL REPRESENTATIONS AND WARRANTIES OF MERCHANTABILITY, FITNESS FOR A PARTICULAR PURPOSE, TITLE, NON-INFRINGEMENT, AND THOSE ARISING FROM A COURSE OF DEALING, TRADE USAGE, TRADE CUSTOM OR TRADE PRACTICE.**

**onsemi** reserves the right to make changes without further notice to any board.

You are responsible for determining whether the board will be suitable for your intended use or application or will achieve your intended results. Prior to using or distributing any systems that have been evaluated, designed or tested using the board, you agree to test and validate your design to confirm the functionality for your application. Any technical, applications or design information or advice, quality characterization, reliability data or other services provided by **onsemi** shall not constitute any representation or warranty by **onsemi**, and no additional obligations or liabilities shall arise from **onsemi** having provided such information or services.

**onsemi** products including the boards are not designed, intended, or authorized for use in life support systems, or any FDA Class 3 medical devices or medical devices with a similar or equivalent classification in a foreign jurisdiction, or any devices intended for implantation in the human body. You agree to indemnify, defend and hold harmless **onsemi**, its directors, officers, employees, representatives, agents, subsidiaries, affiliates, distributors, and assigns, against any and all liabilities, losses, costs, damages, judgments, and expenses, arising out of any claim, demand, investigation, lawsuit, regulatory action or cause of action arising out of or associated with any unauthorized use, even if such claim alleges that **onsemi** was negligent regarding the design or manufacture of any products and/or the board.

This evaluation board/kit does not fall within the scope of the European Union directives regarding electromagnetic compatibility, restricted substances (RoHS), recycling (WEEE), FCC, CE or UL, and may not meet the technical requirements of these or other related directives.

FCC WARNING – This evaluation board/kit is intended for use for engineering development, demonstration, or evaluation purposes only and is not considered by **onsemi** to be a finished end product fit for general consumer use. It may generate, use, or radiate radio frequency energy and has not been tested for compliance with the limits of computing devices pursuant to part 15 of FCC rules, which are designed to provide reasonable protection against radio frequency interference. Operation of this equipment may cause interference with radio communications, in which case the user shall be responsible, at its expense, to take whatever measures may be required to correct this interference.

**onsemi** does not convey any license under its patent rights nor the rights of others.

LIMITATIONS OF LIABILITY: **onsemi** shall not be liable for any special, consequential, incidental, indirect or punitive damages, including, but not limited to the costs of requalification, delay, loss of profits or goodwill, arising out of or in connection with the board, even if **onsemi** is advised of the possibility of such damages. In no event shall **onsemi**'s aggregate liability from any obligation arising out of or in connection with the board, under any theory of liability, exceed the purchase price paid for the board, if any.

The board is provided to you subject to the license and other terms per **onsemi**'s standard terms and conditions of sale. For more information and documentation, please visit [www.onsemi.com](http://www.onsemi.com).

## ADDITIONAL INFORMATION

### TECHNICAL PUBLICATIONS:

Technical Library: [www.onsemi.com/design/resources/technical-documentation](http://www.onsemi.com/design/resources/technical-documentation)  
onsemi Website: [www.onsemi.com](http://www.onsemi.com)

### ONLINE SUPPORT: [www.onsemi.com/support](http://www.onsemi.com/support)

For additional information, please contact your local Sales Representative at [www.onsemi.com/support/sales](http://www.onsemi.com/support/sales)

