

1-Mbit (128K x 8) Static RAM

Features

- **Temperature Ranges**
 - Commercial: 0°C to 70°C
 - Industrial: -40°C to 85°C
 - Automotive: -40°C to 125°C
- **4.5V–5.5V operation**
- **CMOS for optimum speed/power**
- **Low active power**
(70 ns, LL version, Commercial, Industrial)
 - 82.5 mW (max.) (15 mA)
- **Low standby power**
(70 ns, LL version, Commercial, Industrial)
 - 110 μ W (max.) (15 μ A)
- **Automatic power-down when deselected**
- **TTL-compatible inputs and outputs**
- **Easy memory expansion with \overline{CE}_1 , \overline{CE}_2 , and \overline{OE} options**

Functional Description^[1]

The CY62128B is a high-performance CMOS static RAM organized as 131,072 words by 8 bits. Easy memory expansion is provided by an active LOW Chip Enable (\overline{CE}_1), an active HIGH Chip Enable (CE_2), an active LOW Output Enable (\overline{OE}), and three-state drivers. This device has an automatic power-down feature that reduces power consumption by more than 75% when deselected.

Writing to the device is accomplished by taking Chip Enable One (\overline{CE}_1) and Write Enable (\overline{WE}) inputs LOW and Chip Enable Two (CE_2) input HIGH. Data on the eight I/O pins (I/O_0 through I/O_7) is then written into the location specified on the address pins (A_0 through A_{16}).

Reading from the device is accomplished by taking Chip Enable One (\overline{CE}_1) and Output Enable (\overline{OE}) LOW while forcing Write Enable (\overline{WE}) and Chip Enable Two (CE_2) HIGH. Under these conditions, the contents of the memory location specified by the address pins will appear on the I/O pins.

The eight input/output pins (I/O_0 through I/O_7) are placed in a high-impedance state when the device is deselected (\overline{CE}_1 HIGH or CE_2 LOW), the outputs are disabled (\overline{OE} HIGH), or during a write operation (\overline{CE}_1 LOW, CE_2 HIGH, and \overline{WE} LOW).

The CY62128B is available in a standard 450-mil-wide SOIC, 32-pin TSOP type I and STSOP packages.

Logic Block Diagram

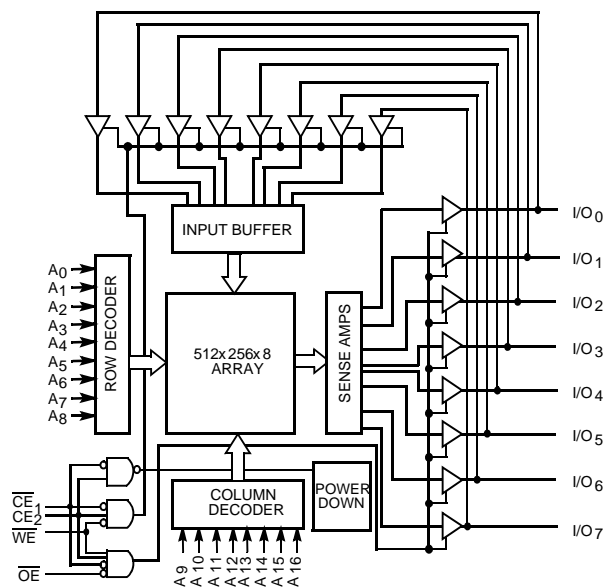

Note:

1. For best-practice recommendations, please refer to the Cypress application note "System Design Guidelines" on <http://www.cypress.com>.

Product Portfolio

Product		V _{CC} Range (V)			Speed (ns)	Power Dissipation			
						Operating, I _{CC} (mA)		Standby, I _{SB2} (μA)	
		Min.	Typ. ^[2]	Max.		Typ. ^[2]	Max.	Typ. ^[2]	Max.
CY62128BLL	Industrial	4.5	5.0	5.5	55	7.5	20	2.5	15
	Industrial				70	6	15	2.5	15
	Automotive				70	6	25	2.5	25

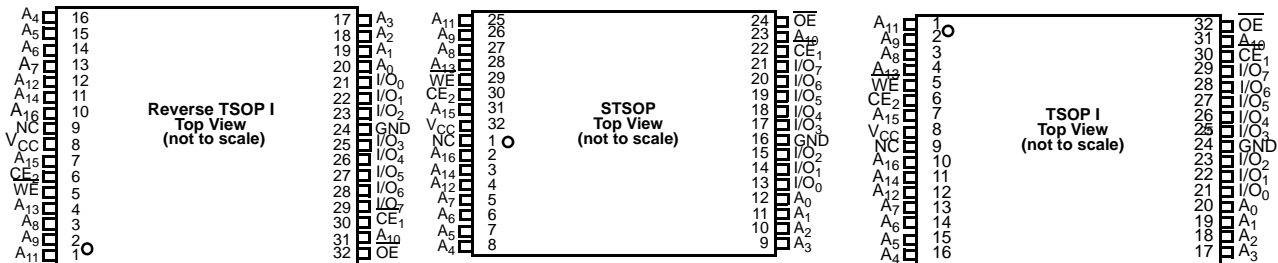
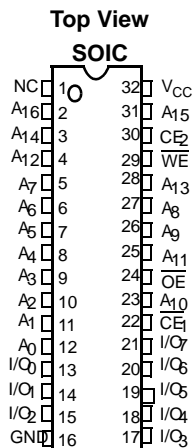
Pin Configurations

Pin Definitions

Input	A₀-A₁₆ . Address Inputs
Input/Output	I/O₀-I/O₇ . Data lines. Used as input or output lines depending on operation
Input/Control	WE . Write Enable, Active LOW. When selected LOW, a WRITE is conducted. When selected HIGH, a READ is conducted.
Input/Control	CE₁ . Chip Enable 1, Active LOW.
Input/Control	CE₂ . Chip Enable 2, Active HIGH.
Input/Control	OE . Output Enable, Active LOW. Controls the direction of the I/O pins. When LOW, the I/O pins behave as outputs. When deasserted HIGH, I/O pins are three-stated, and act as input data pins
Ground	GND . Ground for the device
Power Supply	V_{CC} . Power supply for the device

Note:

- Typical values are included for reference only and are not tested or guaranteed. Typical values are an average of the distribution across normal production variations as measured at V_{CC} = 5.0V, T_A = 25°C, and t_{AA} = 70 ns.

Maximum Ratings

(Above which the useful life may be impaired. For user guidelines, not tested.)

Storage Temperature -65°C to +150°C

Ambient Temperature with Power Applied..... -55°C to +125°C

Supply Voltage on V_{CC} to Relative GND^[3] -0.5V to +7.0V

DC Voltage Applied to Outputs in High-Z State^[3] -0.5V to $V_{CC} + 0.5V$

DC Input Voltage^[3]..... -0.5V to $V_{CC} + 0.5V$

Current into Outputs (LOW)..... 20 mA

Static Discharge Voltage..... > 2001V (per MIL-STD-883, Method 3015)

Latch-up Current..... > 200 mA

Operating Range

Range	Ambient Temperature (T_A) ^[4]	V_{CC}
Commercial	0°C to +70°C	5V ± 10%
Industrial	-40°C to +85°C	5V ± 10%
Automotive	-40°C to +125°C	5V ± 10%

Electrical Characteristics Over the Operating Range

Parameter	Description	Test Conditions	CY62128B-55			CY62128B-70			Unit	
			Min.	Typ. ^[2]	Max.	Min.	Typ. ^[2]	Max.		
V_{OH}	Output HIGH Voltage	$V_{CC} = \text{Min.}, I_{OH} = -1.0 \text{ mA}$	2.4			2.4			V	
V_{OL}	Output LOW Voltage	$V_{CC} = \text{Min.}, I_{OL} = 2.1 \text{ mA}$			0.4			0.4	V	
V_{IH}	Input HIGH Voltage		2.2		$V_{CC} + 0.3$	2.2		$V_{CC} + 0.3$	V	
V_{IL}	Input LOW Voltage ^[3]		-0.3		0.8	-0.3		0.8	V	
I_{IX}	Input Load Current	$GND \leq V_I \leq V_{CC}$		-1	+1	-1		+1	μA	
			Automotive				-10		+10	μA
I_{OZ}	Output Leakage Current	$GND \leq V_I \leq V_{CC},$ Output Disabled		-1	+1	-1		+1	μA	
			Automotive				-10		+10	μA
I_{OS}	Output Short Circuit Current ^[5]	$V_{CC} = \text{Max.}, V_{OUT} = GND$			-300			-300	mA	
I_{CC}	V_{CC} Operating Supply Current	$V_{CC} = \text{Max.},$ $I_{OUT} = 0 \text{ mA},$ $f = f_{MAX} = 1/t_{RC}$	Industrial, Commercial		7.5	20		6	15	mA
			Automotive					6	25	mA
I_{SB1}	Automatic CE Power-down Current —TTL Inputs	Max. $V_{CC},$ $CE_1 \geq V_{IH}$ or $CE_2 \leq V_{IL},$ $V_{IN} \geq V_{IH}$ or $V_{IN} \leq V_{IL}, f = f_{MAX}$	Industrial Commercial		0.1	2		0.1	1	mA
			Automotive					0.1	2	mA
I_{SB2}	Automatic CE Power-down Current —CMOS Inputs	Max. $V_{CC},$ $CE_1 \geq V_{CC} - 0.3V,$ or $CE_2 \leq 0.3V,$ $V_{IN} \geq V_{CC} - 0.3V,$ or $V_{IN} \leq 0.3V, f = 0$	Industrial Commercial		2.5	15		2.5	15	μA
			Automotive					2.5	25	μA

Notes:

- V_{IL} (min.) = -2.0V for pulse durations of less than 20 ns.
- T_A is the "Instant On" case temperature.
- Not more than one output should be shorted at one time. Duration of the short circuit should not exceed 30 seconds.

Thermal Resistance^[6]

Parameter	Description	Test Conditions	32 SOIC	32 TSOP	32 STSOP	32 RTSOP	Unit
Θ_{JA}	Thermal Resistance (Junction to Ambient)	Test conditions follow standard test methods and procedures for measuring thermal impedance, per EIA / JESD51.	66.17	97.44	105.14	97.44	°C/W
Θ_{JC}	Thermal Resistance (Junction to Case)		30.87	26.05	14.09	26.05	°C/W

Capacitance^[6]

Parameter	Description	Test Conditions	Max.	Unit
C_{IN}	Input Capacitance	$T_A = 25^\circ\text{C}$, $f = 1\text{ MHz}$, $V_{CC} = 5.0\text{V}$	9	pF
C_{OUT}	Output Capacitance		9	pF

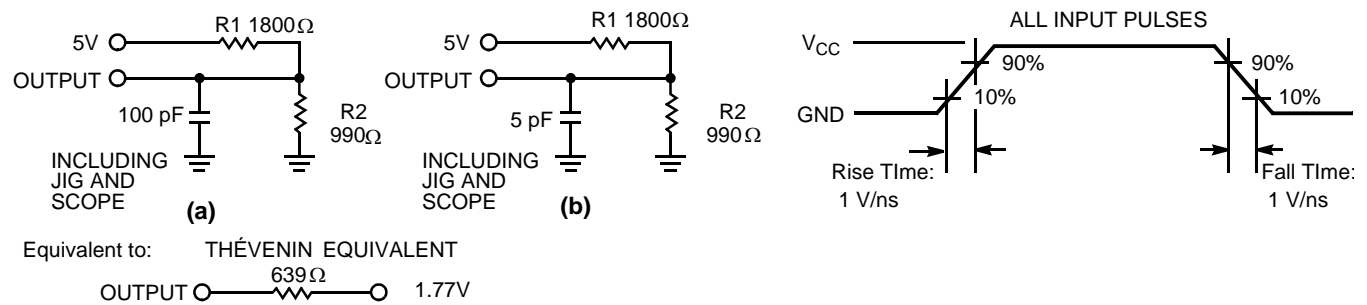
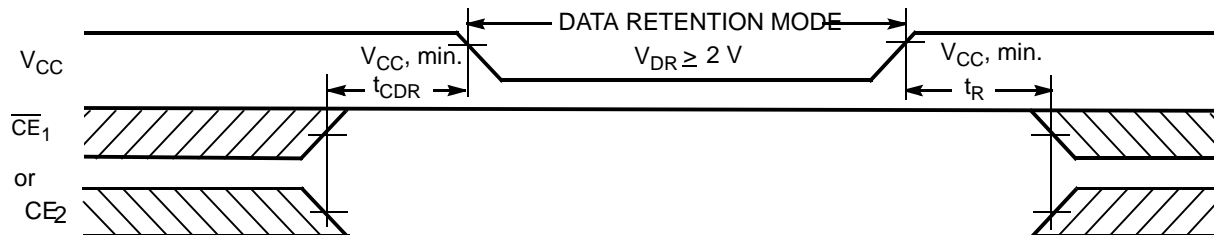
AC Test Loads and Waveforms

Data Retention Waveform

Data Retention Characteristics (Over the Operating Range for "LL" version only)

Parameter	Description	Conditions	Min.	Typ.	Max.	Unit
V_{DR}	V_{CC} for Data Retention		2.0			V
I_{CCDR}	Data Retention Current	$V_{CC} = V_{DR} = 2.0\text{V}$, $\overline{CE}_1 \geq V_{CC} - 0.3\text{V}$, or $\overline{CE}_2 \leq 0.3\text{V}$, $V_{IN} \geq V_{CC} - 0.3\text{V}$ or, $V_{IN} \leq 0.3\text{V}$		1.5	15	μA
t_{CDR}	Chip Deselect to Data Retention Time		0			ns
t_R	Operation Recovery Time		70			ns

Note:

6. Tested initially and after any design or process changes that may affect these parameters.

Switching Characteristics^[7] Over the Operating Range

Parameter	Description	62128B-55		62128B-70		Unit
		Min.	Max.	Min.	Max.	
READ CYCLE						
t_{RC}	Read Cycle Time	55		70		ns
t_{AA}	Address to Data Valid		55		70	ns
t_{OHA}	Data Hold from Address Change	5		5		ns
t_{ACE}	\overline{CE}_1 LOW to Data Valid, CE_2 HIGH to Data Valid		55		70	ns
t_{DOE}	\overline{OE} LOW to Data Valid		20		35	ns
t_{LZOE}	\overline{OE} LOW to Low Z	0		0		ns
t_{HZOE}	\overline{OE} HIGH to High Z ^[7, 9]		20		25	ns
t_{LZCE}	\overline{CE}_1 LOW to Low Z, CE_2 HIGH to Low Z ^[9]	5		5		ns
t_{HZCE}	\overline{CE}_1 HIGH to High Z, CE_2 LOW to High Z ^[8, 9]		20		25	ns
t_{PU}	\overline{CE}_1 LOW to Power-up, CE_2 HIGH to Power-up	0		0		ns
t_{PD}	\overline{CE}_1 HIGH to Power-down, CE_2 LOW to Power-down		55		70	ns
WRITE CYCLE^[10]						
t_{WC}	Write Cycle Time	55		70		ns
t_{SCE}	\overline{CE}_1 LOW to Write End, CE_2 HIGH to Write End	45		60		ns
t_{AW}	Address Set-up to Write End	45		60		ns
t_{HA}	Address Hold from Write End	0		0		ns
t_{SA}	Address Set-up to Write Start	0		0		ns
t_{PWE}	\overline{WE} Pulse Width	45		50		ns
t_{SD}	Data Set-up to Write End	25		30		ns
t_{HD}	Data Hold from Write End	0		0		ns
t_{LZWE}	\overline{WE} HIGH to Low Z ^[9]	5		5		ns
t_{HZWE}	\overline{WE} LOW to High Z ^[8, 9]		20		25	ns

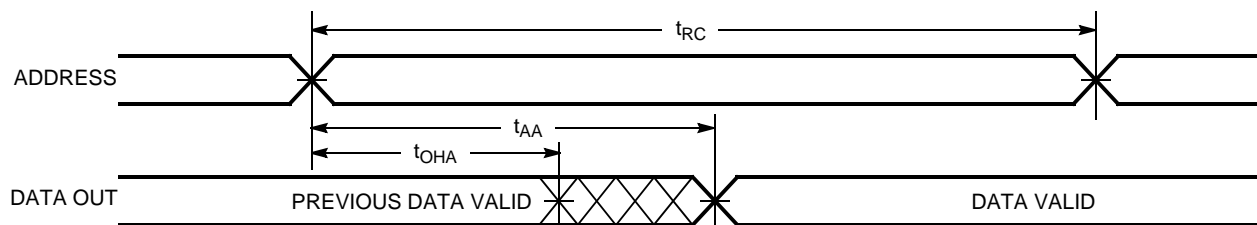
Switching Waveforms
Read Cycle No.1^[12, 13]

Notes:

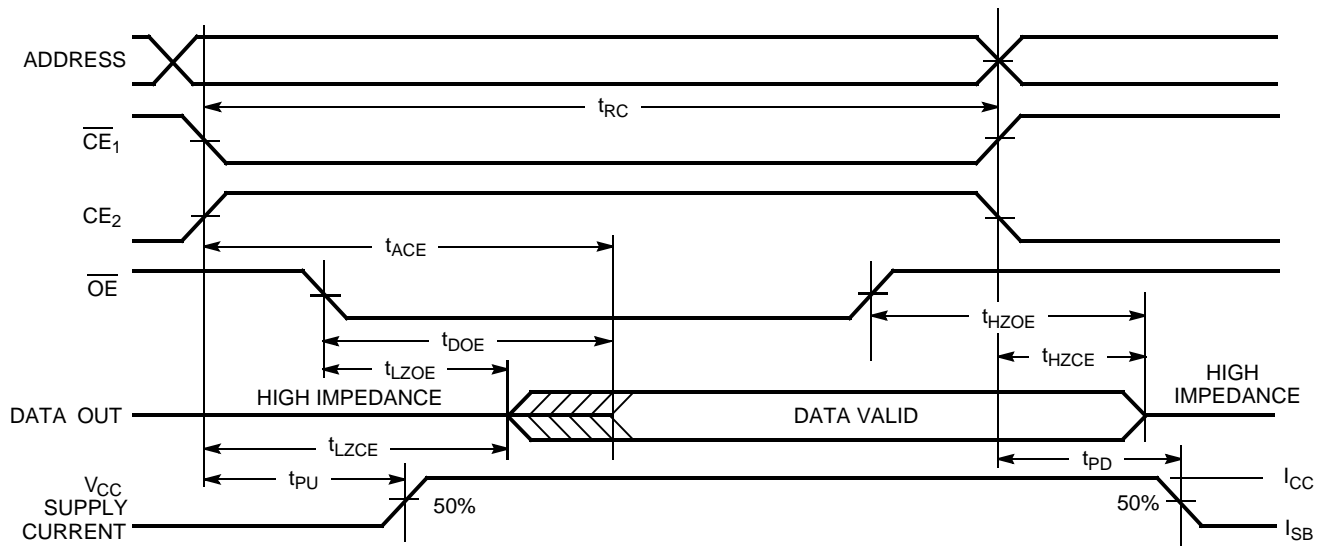
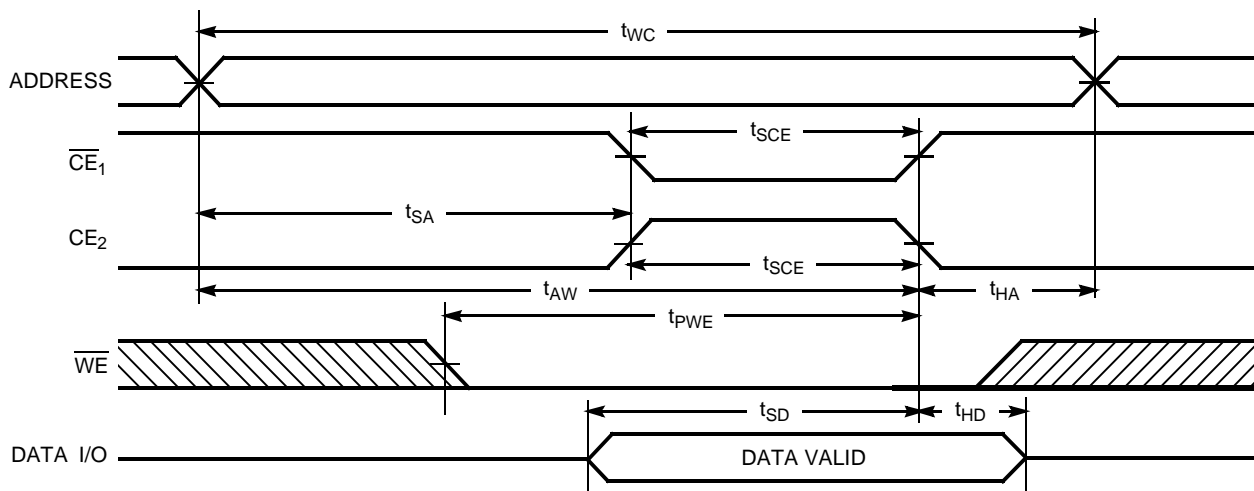
- Test conditions assume signal transition time of 5 ns or less, timing reference levels of 1.5V, input pulse levels of 0 to 3.0V, and output loading of the specified I_{OL}/I_{OH} and 100-pF load capacitance.
- t_{HZOE} , t_{HZCE} , and t_{HZWE} are specified with a load capacitance of 5 pF as in (b) of AC Test Loads. Transition is measured ± 500 mV from steady-state voltage.
- At any given temperature and voltage condition, t_{HZCE} is less than t_{LZCE} , t_{HZOE} is less than t_{LZOE} , and t_{HZWE} is less than t_{LZWE} for any given device.
- The internal write time of the memory is defined by the overlap of \overline{CE}_1 LOW, CE_2 HIGH, and \overline{WE} LOW. \overline{CE}_1 and \overline{WE} must be LOW and CE_2 HIGH to initiate a write, and the transition of any of these signals can terminate the write. The input data set-up and hold timing should be referenced to the leading edge of the signal that terminates the write.
- No input may exceed $V_{CC} + 0.5V_{\overline{CE}_1}$.
- Device is continuously selected. OE , $CE_1 = V_{IL}$, $CE_2 = V_{IH}$.
- \overline{WE} is HIGH for read cycle.

Switching Waveforms (continued)
Read Cycle No. 2 (\overline{OE} Controlled)^[13, 14]

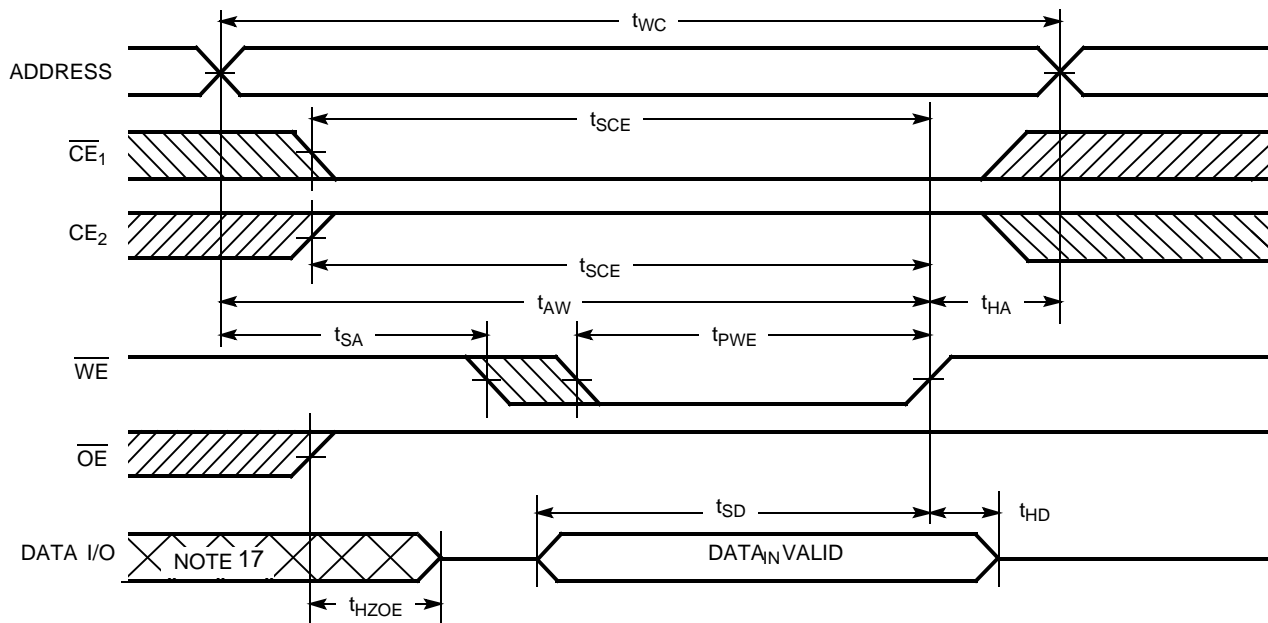
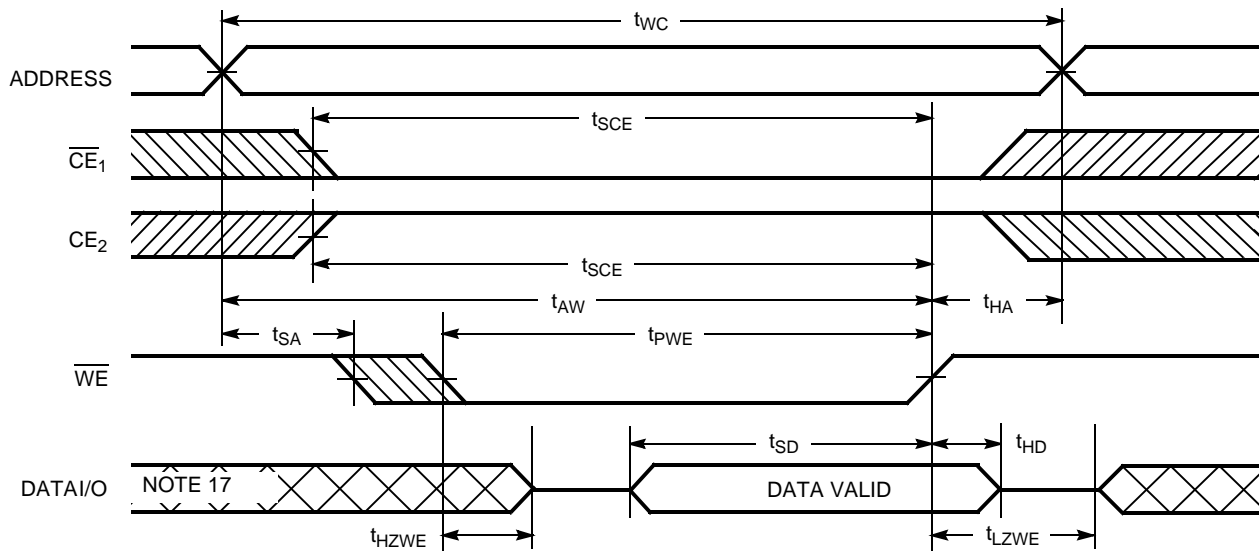
Write Cycle No. 1 (\overline{CE}_1 or CE_2 Controlled)^[15, 16]

Notes:

14. Address valid prior to or coincident with \overline{CE}_1 transition LOW and CE_2 transition HIGH.
15. Data I/O is high impedance if $\overline{OE} = V_{IH}$.
16. If \overline{CE}_1 goes HIGH or CE_2 goes LOW simultaneously with \overline{WE} going HIGH, the output remains in a high-impedance state.

Switching Waveforms (continued)
Write Cycle No. 2 (\overline{WE} Controlled, \overline{OE} HIGH During Write)^[15, 16]

Write Cycle No.3 (\overline{WE} Controlled, \overline{OE} LOW)^[15, 16]

Note:

17. During this period the I/Os are in the output state and input signals should not be applied.

Truth Table

\overline{CE}_1	\overline{CE}_2	\overline{OE}	\overline{WE}	I/O ₀ -I/O ₇	Mode	Power
H	X	X	X	High Z	Power-down	Standby (I _{SB})
X	L	X	X	High Z	Power-down	Standby (I _{SB})
L	H	L	H	Data Out	Read	Active (I _{CC})
L	H	X	L	Data In	Write	Active (I _{CC})
L	H	H	H	High Z	Selected, Outputs Disabled	Active (I _{CC})

Ordering Information

Speed (ns)	Ordering Code	Package Name	Package Type	Operating Range
55	CY62128BLL-55SI	S34	32-Lead 450-Mil SOIC	Industrial
	CY62128BLL-55SXI	S34	32-Lead 450-Mil SOIC (Pb-Free)	Industrial
	CY62128BLL-55SC	S34	32-Lead 450-Mil SOIC	Commercial
	CY62128BLL-55SXC	S34	32-Lead 450-Mil SOIC (Pb-Free)	Commercial
	CY62128BLL-55ZI	Z32	32-Lead TSOP Type I	Industrial
	CY62128BLL-55ZXI	Z32	32-Lead TSOP Type I (Pb-Free)	Industrial
	CY62128BLL-55ZAI	ZA32	32-Lead STSOP Type I	Industrial
	CY62128BLL-55ZAXI	ZA32	32-Lead STSOP Type I (Pb-Free)	Industrial
	CY62128BLL-55ZRI	ZR32	32-Lead Reverse TSOP Type I	Industrial
70	CY62128BLL-70SI	S34	32-Lead 450-Mil SOIC I	Industrial
	CY62128BLL-70SXI	S34	32-Lead 450-Mil SOIC I (Pb-Free)	Industrial
	CY62128BLL-70SC	S34	32-Lead 450-Mil SOIC I	Commercial
	CY62128BLL-70SXC	S34	32-Lead 450-Mil SOIC I (Pb-Free)	Commercial
	CY62128BLL-70SE	S34	32-Lead 450-Mil SOIC I	Automotive
	CY62128BLL-70SXE	S34	32-Lead 450-Mil SOIC I (Pb-Free)	Automotive
	CY62128BLL-70ZI	Z32	32-Lead TSOP Type I	Industrial
	CY62128BLL-70ZC	Z32	32-Lead TSOP Type I	Commercial
	CY62128BLL-70ZE	Z32	32-Lead TSOP Type I	Automotive
	CY62128BLL-70ZXE	Z32	32-Lead TSOP Type I (Pb-Free)	Automotive
	CY62128BLL-70ZAI	ZA32	32-Lead STSOP Type I	Industrial
	CY62128BLL-70ZAXI	ZA32	32-Lead STSOP Type I (Pb-Free)	Industrial
	CY62128BLL-70ZAE	ZA32	32-Lead STSOP Type I	Automotive
	CY62128BLL-70ZAXE	ZA32	32-Lead STSOP Type I (Pb-Free)	Automotive
	CY62128BLL-70ZRXE	ZR32	32-Lead Reverse TSOP Type I (Pb-Free)	Automotive

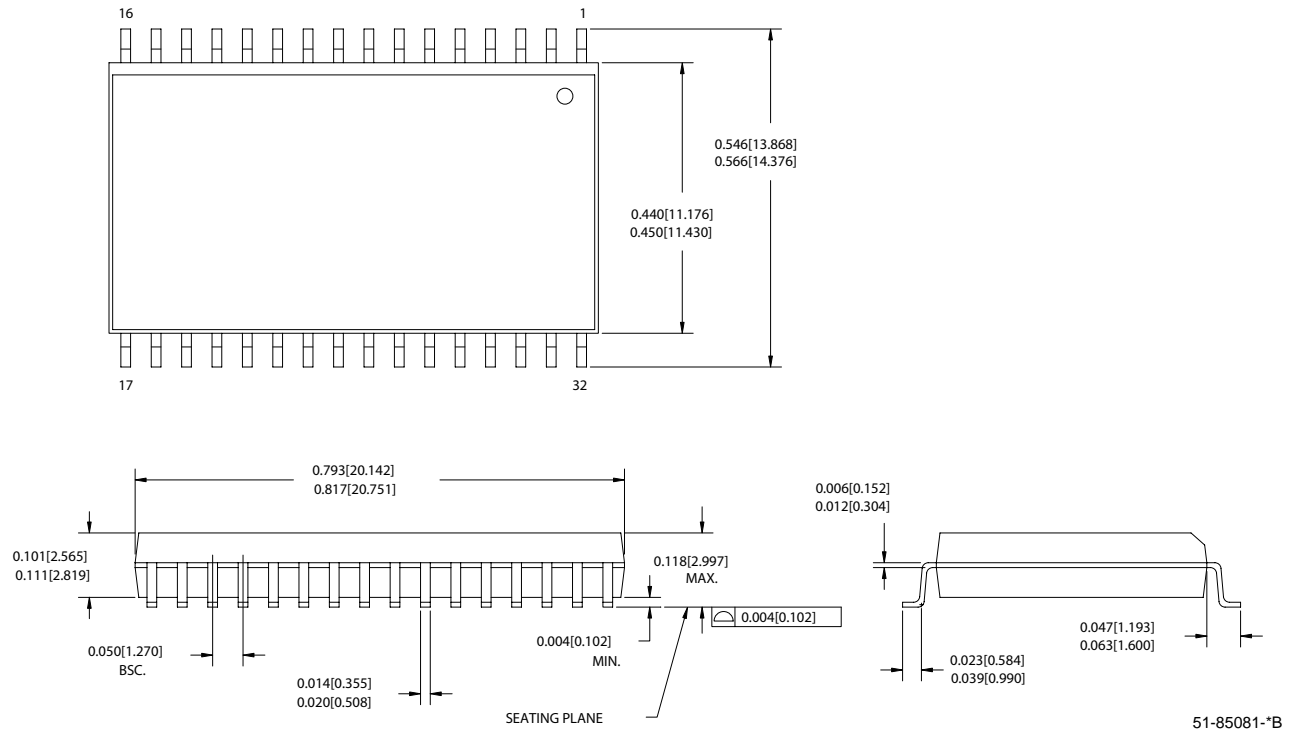
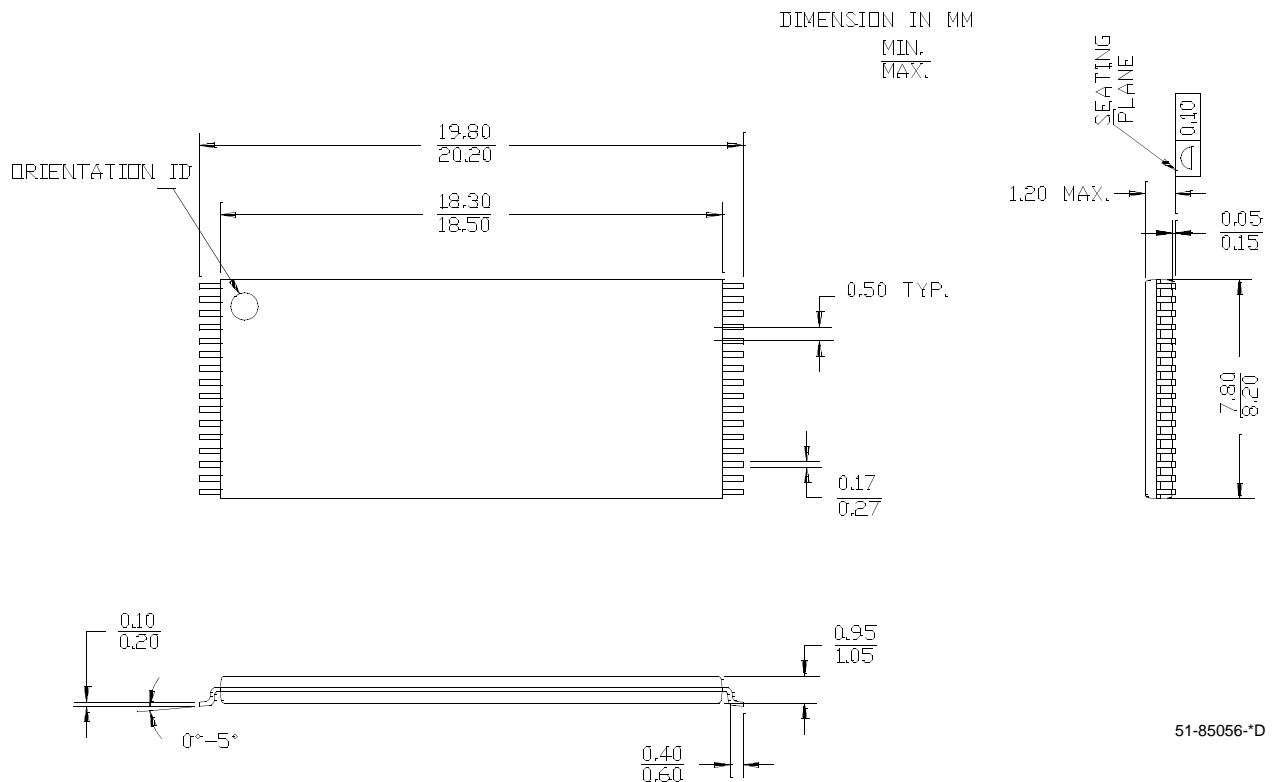
Package Diagrams
32-Lead (450 MIL) Molded SOIC S34

32-Lead Thin Small Outline Package Type I (8x20 mm) Z32

Package Diagrams (continued)

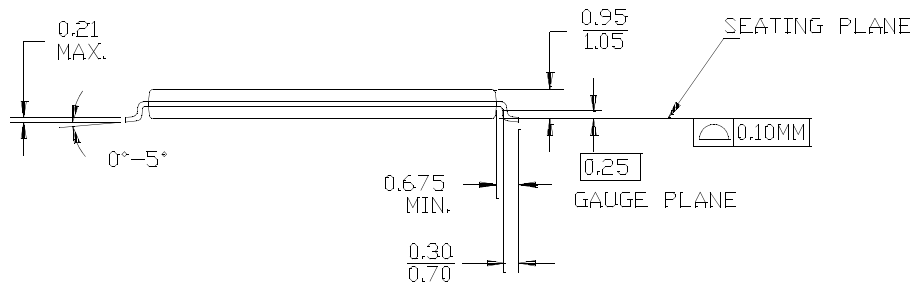
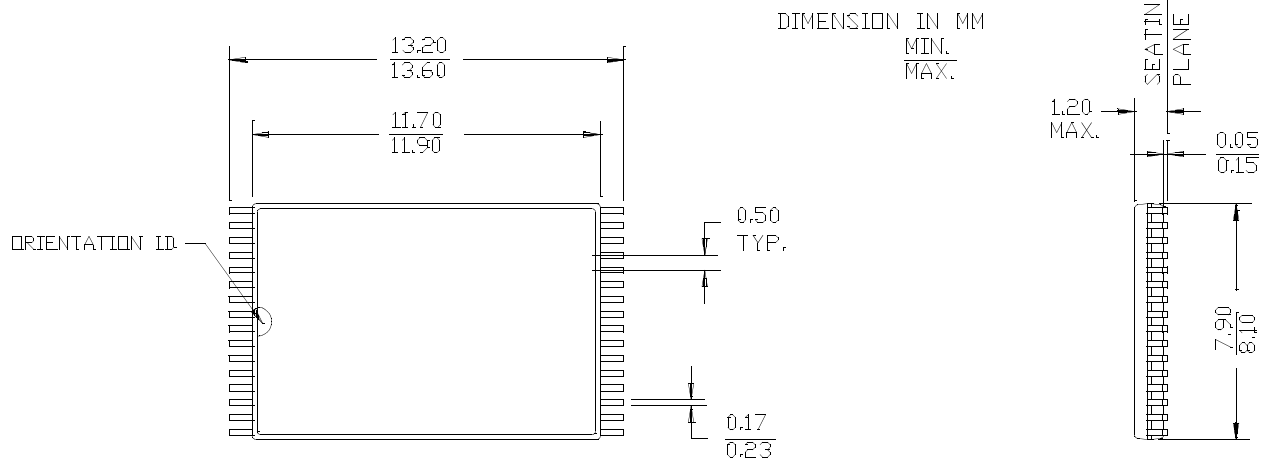
32-Lead Shrunken Thin Small Outline Package (8x13.4 mm) ZA32



51-85094-*D

32-Lead Reverse Thin Small Outline Package ZR32

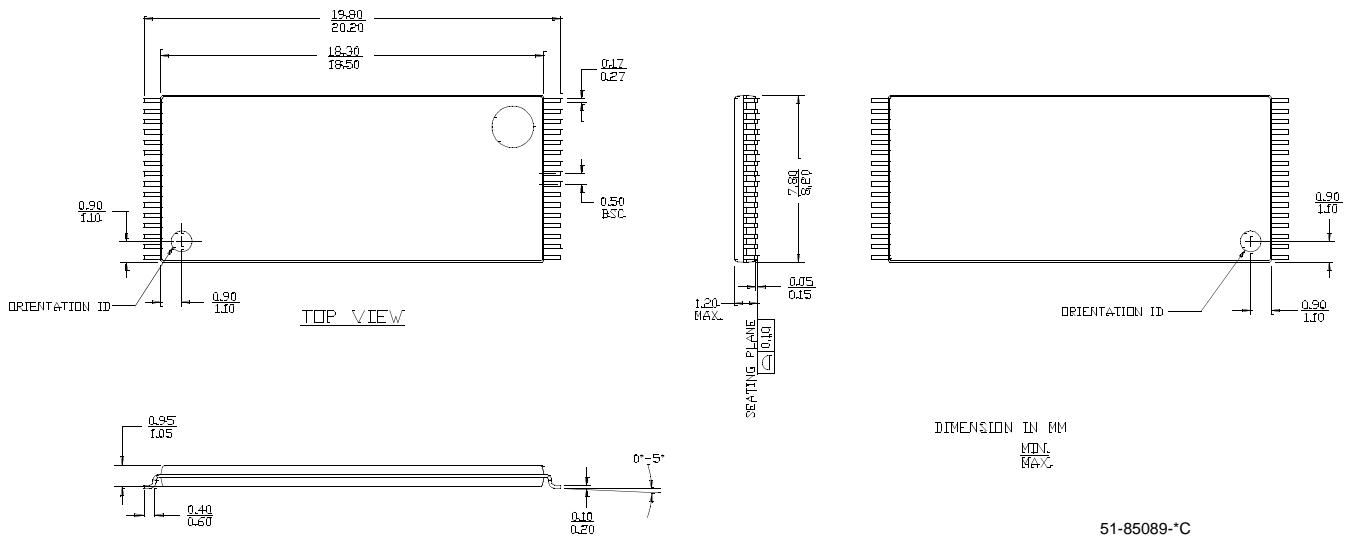

51-85089-*C

All product and company names mentioned in this document are the trademarks of their respective holders.

Document History Page

Document Title: CY62128B MoBL [®] 1-Mbit (128K x 8) Static RAM				
Document Number: 38-05300				
REV.	ECN NO.	Issue Date	Orig. of Change	Description of Change
**	116566	06/20/02	DSG	Changed from Spec number: 38-00524 to 38-05300
*A	126601	06/09/03	JUI	Changed CE to CE ₁ and added CE ₂ ≤ 0.3V in Data Retention Characteristics table Removed these part numbers from Ordering Information table: CY62128BLL-55ZC, CY62128BLL-55ZAC, CY62128BLL-55ZRC, CY62128BLL-70ZAC, CY62128BLL-70ZRI, CY62128BLL-70ZRC
*B	239134	See ECN	AJU	Added Thermal Resistance table Added Automotive product information
*C	334398	See ECN	SYT	Added Pb-Free part numbers to the Ordering info on Page #8