

SERIES 805 TRIPLE-START ACME THREAD Mighty Mouse Connectors and Cables



Environmental, Rear Panel Mount, Jam-Nut Bulkhead Feedthrough



Series 805 Bulkhead Feedthrough connector provides a separable connection on both sides of a mounting panel. Available in shell sizes 8 to 23. Mates with all high density triple-start threaded connectors with the same polarization and opposite contact genders (805-001 and 805-002). Copper alloy gold-plated contacts, pin to pin, pin to socket, and socket to socket. Aluminum alloy or stainless steel shells with seven standard finishes. Please contact the factory for additional materials and finishes available.

How To Order							
Sample Part Number	805-066	-07	M	8-7	P	P	N
Series	805-066 = Bulkhead Feedthrough Receptacle						
Shell Style	-07 = Jam-Nut, Rear Panel Mount						
Shell Material and Finish	C = Aluminum / Black Anodize (Non-Conductive); RoHS Compliant M = Aluminum / Electroless Nickel; RoHS Compliant MT = Aluminum / Nickel-PTFE RoHS Compliant NF = Aluminum / Cadmium with Olive Drab Chromate ZN = Aluminum / Zinc-Nickel with Olive Drab Chromate ZNU = Aluminum / Zinc-Nickel with Black Chromate Z1 = Stainless Steel / Passivated; RoHS Compliant						
Shell Size - Insert Arrangement	See Contact Arrangements Page J-6						
Contact Type ² (Jam-Nut Side)	P = Pin S = Socket						
Contact Type ² (Other Side)	P = Pin S = Socket						
Shell Key Position (See Table I)	A = Normal B = Pos. B C = Pos. C D = Pos. D E = Pos. E F = Pos. F						

Key Position	Key Rotation	
	A	B
A (Normal)	150°	210°
B	75°	210°
C	95°	230°
D	140°	275°
E	75°	275°
F	95°	210°

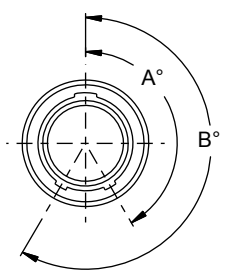

NOTES

1. This connector mates with all quick coupling high density plug connectors with same polarization and opposite contact gender 805-001, 805-002
2. Connector with PP and SS contact styles will cause the arrangement pattern to be mirrored about the vertical centerline.
3. Connectors supplied with standard power contacts. Consult factory for coax or other special contacts
4. See page J-11 for recommended panel cut-outs

Contact Sizes	Test Voltage
23	750 Vac
20 HD	1000 Vac
16, 12, 8	1800 Vac

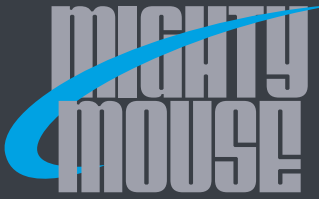

SERIES 805 TRIPLE-START ACME THREAD Mighty Mouse Connectors and Cables



Environmental Jam-Nut, Rear Panel Mount Bulkhead Feedthrough

JAM-NUT, REAR PANEL MOUNT - SHELL STYLE 07

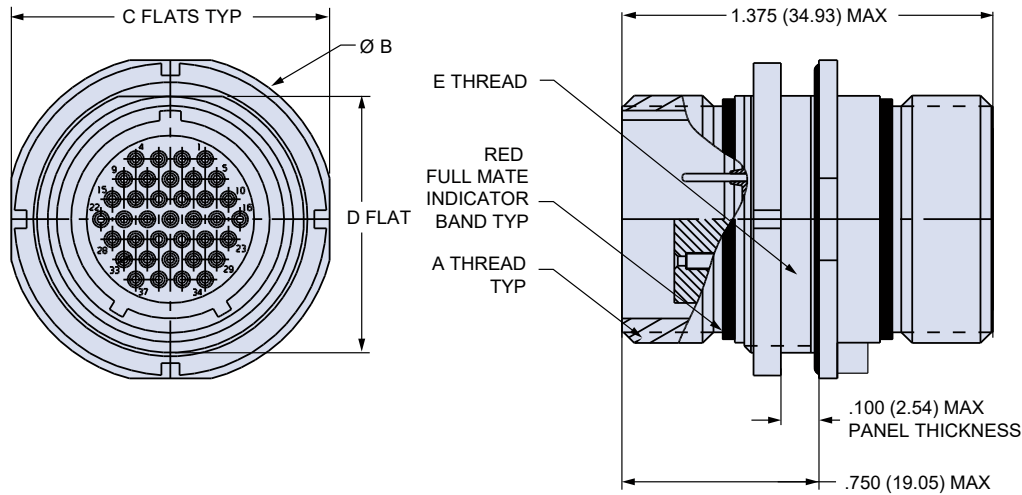

Table II: Dimensions

Shell Size	A Thread	Ø B	C Flat	D Flat	E Thread
8	.5000-1P-.31L-TS	.760 (19.30)	.730 (18.54)	.535 (13.59)	.5625-28 UNEF-2A
9	.5625-1P-.31L-TS	.880 (22.35)	.850 (21.59)	.661 (16.79)	.6875-28 UN-2A
10	.6250-1P-.31L-TS	.880 (22.35)	.850 (21.59)	.661 (16.79)	.6875-28 UN-2A
11	.6875-1P-.31L-TS	.955 (24.26)	.925 (23.50)	.721 (18.31)	.7500-28 UN-2A
12	.7500-1P-.31L-TS	1.060 (26.92)	1.035 (26.29)	.784 (19.91)	.8125-28 UN-2A
13	.8125-1P-.31L-TS	1.120 (28.45)	1.090 (27.69)	.843 (21.41)	.8750-28 UN-2A
15	.9375-1P-.31L-TS	1.203 (30.56)	1.173 (29.79)	.970 (24.64)	1.0000-28 UN-2A
18	1.1250-1P-.31L-TS	1.389 (35.28)	1.359 (34.52)	1.147 (29.13)	1.1875-28 UN-2A
19	1.1875-1P-.31L-TS	1.450 (36.83)	1.420 (36.07)	1.221 (31.01)	1.2500-28 UN-2A
21	1.3125-1P-.31L-TS	1.590 (40.39)	1.560 (39.62)	1.350 (34.29)	1.3750-28 UN-2A
23	1.4375-1P-.31L-TS	1.705 (43.31)	1.675 (42.55)	1.470 (37.34)	1.5000-28 UN-2A

Material and finish

- Shell, jam-nut: aluminum alloy or CRES / see how to order table
- Insulators: liquid crystal polymer / N.A.
- Interfacial seal, O-ring, peripheral seal: fluorosilicone / N.A.
- Contact: copper alloy / gold plate per ASTM B 488, Type II, Code C, Class 1.25, over a suitable underplate

Jam-Nut Panel Cutout

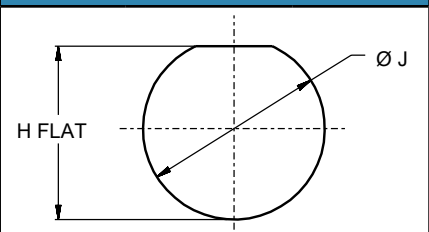

Shell Size	H Flat	Ø J
8	.545 (13.84)	.572 (14.53)
	.541 (13.74)	.567 (14.40)
9	.671 (17.04)	.698 (17.73)
	.667 (16.94)	.693 (17.60)
10	.671 (17.04)	.698 (17.73)
	.667 (16.94)	.693 (17.60)
11	.731 (18.57)	.760 (19.30)
	.727 (18.47)	.755 (19.18)
12	.794 (20.17)	.822 (20.88)
	.790 (20.07)	.817 (20.75)
13	.851 (21.62)	.885 (22.48)
	.847 (21.51)	.881 (22.38)
15	.980 (24.89)	1.010 (25.65)
	.976 (24.79)	1.005 (25.53)
18	1.157 (29.39)	1.198 (30.43)
	1.153 (29.29)	1.193 (30.30)
19	1.231 (31.27)	1.260 (32.00)
	1.227 (31.17)	1.255 (31.88)
21	1.358 (34.49)	1.383 (35.13)
	1.354 (34.39)	1.381 (35.08)
23	1.480 (37.59)	1.510 (38.35)
	1.476 (37.49)	1.505 (38.23)