

CAT3211

I²C Programmable Haptic Driver for Rotary (ERM) DC Motors

Description

The CAT3211 is an H-Bridge motor driver IC that includes an I²C programmable haptic generator state machine, internal oscillator and adjustable LDO voltage regulator, all in one compact solution.

Two operating modes are supported: haptic mode (triggered via H_TRIG pin or register) and vibrator mode (VIB_EN pin or register).

H-TRIG triggers a haptic sequence where Forward, Coast, Reverse and Recovery time durations are controlled. All four timer durations are configured via I²C interface registers.

The LDO output voltage supplying the H-Bridge can be programmed from 2.0 V to 5.0 V or shorted to VIN (using LDOH register). This allows the motor to be safely overdriven for short durations, greatly increasing the user experience.

Driving VIB_EN high sets the H-Bridge to forward direction and LDO voltage to a predefined vibrator setting (using LDOV register). The motor can be continuously and safely driven at low voltages in vibrator mode.

The device is fully protected against POS, NEG and REG short and over current conditions. Thermal shutdown protection prevents damage to the device and system during over temperature junction conditions.

UQFN12 1.7 x 2 mm package is ideal for space constrained applications.

Features

- Haptic Generator Mode with Programmable Timers
- Internal 1 ms Oscillator $\pm 20\%$
- 600 mA Output Drive Current
- High Speed 400 kHz I²C Interface
- Internal LDO with Mode Adjustable Output Voltage
- Supply Voltage Range from 2.7 V to 5.5 V
- Internal H-Bridge Driver (0.8 Ω typ.)
- 1 Amp Diode Clamping Capability (H-Bridge & LDO)
- Zero Current Shutdown Mode
- Thermal Shutdown and Over-current Protection
- Small 1.7 mm x 2 mm, 12-lead UQFN Package
- These Devices are Pb-Free and are RoHS Compliant

Typical Applications

- Eccentric Rotating Mass (ERM) Motor Control
- Haptic Vibrators in Mobile Devices



ON Semiconductor®

<http://onsemi.com>

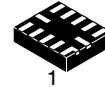

UQFN12
MU SUFFIX
CASE 523AE

MARKING DIAGRAM

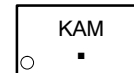

KA = Specific Device Code
M = Date Code
■ = Pb-Free Package

PIN CONNECTIONS

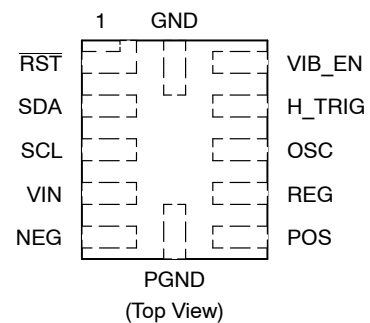

ORDERING INFORMATION

Device	Package	Shipping†
CAT3211MUTAG	UQFN12 (Pb-Free)	3000/ Tape & Reel

†For information on tape and reel specifications, including part orientation and tape sizes, please refer to our Tape and Reel Packaging Specification Brochure, BRD8011/D.

CAT3211

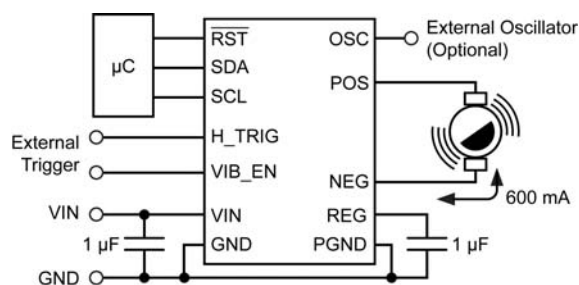

Figure 1. Typical Application Circuit

Table 1. ABSOLUTE MAXIMUM RATINGS

Parameter	Rating	Unit
VIN	6	V
H_TRIG, VIB_EN, SDA, SCL, OSC, RST Voltage	6 to (GND - 0.3)	V
REG Voltage	(VIN + 0.3) to (GND - 0.3)	V
POS, NEG Voltage	(REG + 1.5) to (PGND - 0.3)	V
Storage Temperature Range	-65 to +150	°C
Junction Temperature Range	+150	°C
Lead Temperature	300	°C
ESD Immunity		V
Human Body Model per Standard JESD22-A114E	2000	
Machine Model per Standard JESD22-A115-A	200	
Latch-up Immunity per Standard JESD78		mA
Logic Pins	100	
POS and NEG Pins	600	

Stresses exceeding Maximum Ratings may damage the device. Maximum Ratings are stress ratings only. Functional operation above the Recommended Operating Conditions is not implied. Extended exposure to stresses above the Recommended Operating Conditions may affect device reliability.

Table 2. RECOMMENDED OPERATING CONDITIONS

Parameter	Rating	Unit
VIN	2.7 to 5.5	V
Ambient Temperature Range	-40 to +85	°C
POS and NEG Pin Current (Motor Current)	0 to ±600	mA

Table 3. ELECTRICAL OPERATING CHARACTERISTICS (Note 1)

(Typical values: VIN = 5.0 V, RST = Logic High, TAMB = 25°C unless otherwise specified.)

Parameter	Symbol	Test Conditions	Min	Typ	Max	Units
Operating Current in Haptic Mode (no load) on VIN pin	I _{QH}	Haptic Mode triggered, CHIP_EN = 1 (register)		270	600	µA
Operating Current in Vibrator Mode (no load) on VIN pin	I _{QV}	VIB_EN = High, RST = High, CHIP_EN = 1 (register)		190	600	µA
Standby Current on VIN pin	I _{STBY}	VIB_EN = Low Haptic Mode NOT triggered		1	20	µA
Shutdown Current	I _{SHDN}	RST = Low POS and NEG Shorted			1	µA
H-Bridge Output Drive Resistance (Note 2)	R _{HBRDQ}	VIB_EN = High, REG = VIN, I _{LOAD} = 100 mA		0.8	1.6	Ω

- Limits are fully tested at T_{AMB} = 25°C and guaranteed across temperature by design and characterization statistical analysis.
- Total combined resistance of high-side and low-side switched (measured at 100 mA load). Does not include LDO Switch Resistance.
- Limits guaranteed by design and statistical analysis.

CAT3211

Table 3. ELECTRICAL OPERATING CHARACTERISTICS (Note 1)
(Typical values: VIN = 5.0 V, RST = Logic High, TAMB = 25°C unless otherwise specified.)

Parameter	Symbol	Test Conditions	Min	Typ	Max	Units
REG Output Voltage Accuracy	V _{REG}	Any Programmed Voltage (2.0 V to 5.0 V) LDOV & LDOH	-5		+5	%
LDO Voltage Regulator Dropout Resistance	R _{LDO}	V _{LDO} = 00h & VIB_EN = 1 I _{LOAD} = 100 mA		0.4	0.8	Ω
REG Pin Pull-up Current to VIN	I _{P_REG}	VIN = 5V, REG = GND, no load (POS, NEG floating) Shutdown and Standby Mode		1		mA
Output Drive Current	I _{OUT}	Headroom: VIN - VPOS - VNEG = 1.2 V	600			mA
Output Short Circuit Current Limit (Note 3)	I _{SC}	POS and NEG Pin Shorted	600	850	1000	mA
H_TRIG, VIB_EN, OSC, RST Pins Internal pull-down resistor	R _{IN}			110		kΩ
H_TRIG, VIB_EN, OSC, SDA, SCL, RST Pins Logic High Input Voltage	V _{IH}		1.4			V
	V _{IL}				0.4	V
Thermal Shutdown (Note 3)	T _{SD}			140		°C
Thermal Hysteresis (Note 3)	T _{HYS}			20		°C
Under-Voltage Lockout (UVLO)	V _{UVLO}			2.0		V

- Limits are fully tested at T_{AMB} = 25°C and guaranteed across temperature by design and characterization statistical analysis.
- Total combined resistance of high-side and low-side switched (measured at 100 mA load). Does not include LDO Switch Resistance.
- Limits guaranteed by design and statistical analysis.

Table 4. TIMING CHARACTERISTICS (Note 4)
(Typical values: VIN = 5.0 V, RST = Logic High, TAMB = 25°C unless otherwise specified.)

Name	Symbol	Conditions	Min	Typ	Max	Units
Internal Clock Period (OSC)	T _{OSC}	Reg EXT_OSC (00hB0) = 0		1		ms
Internal Clock Accuracy (OSC)	T _{OSC_ACC}	Reg EXT_OSC (00hB0) = 0	-20		+20	%
External Clock Period (OSC Pin) (Note 5)	T _{OSCEXT}	Reg EXT_OSC (00hB0) = 1	1		2000	μs
External Clock Timeout (OSC Pin)	T _{OSCWTD}	Reg EXT_OSC (00hB0) = 1 Rising Edge to Rising Edge	6	8	10	ms
Clock OSC Low Time	T _{OSCL_MIN}		0.3			μs
Clock OSC High Time	T _{OSCH_MIN}		0.2			μs
H_TRIG High Duration (Note 5)	T _{HTRIG_MIN}		200			ns
VIB_EN Rising to POS/NEG Drive Delay	T _{VIB_R}			40		μs
VIB_EN Falling to POS/NEG Float Delay	T _{VIB_F}			0.3		μs
H_TRIG Trigger to POS/NEG Drive Delay	T _{TRIG_R}			40		μs
Direction Break-Before-Make Delay	T _{BBM}	Haptic mode forward to reverse (no coast)		2		μs

- Limits are fully tested at T_{AMB} = 25°C and guaranteed across temperature by design and characterization statistical analysis.
- Limits guaranteed by design and statistical analysis.

CAT3211

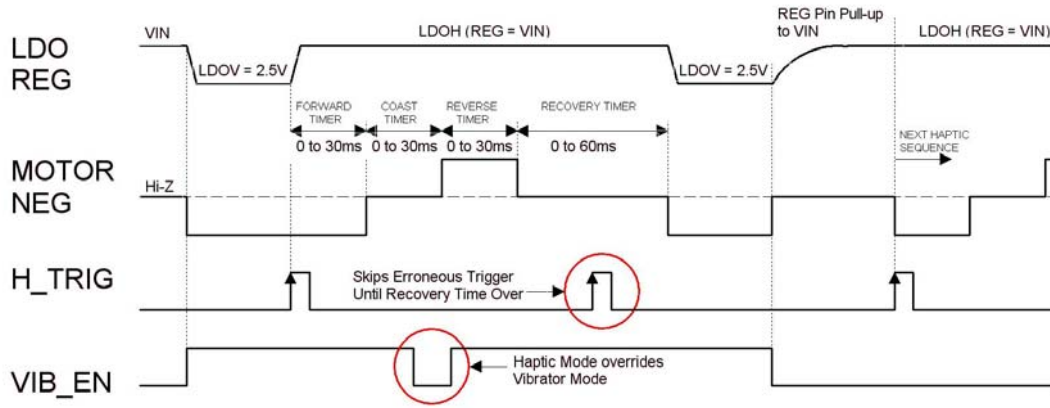

NOTE: Above example has LDOV (REG) = 1Ah and LDOH (REG) = 00h.

Figure 2. Haptic/Vibrator Mode Timing Diagram

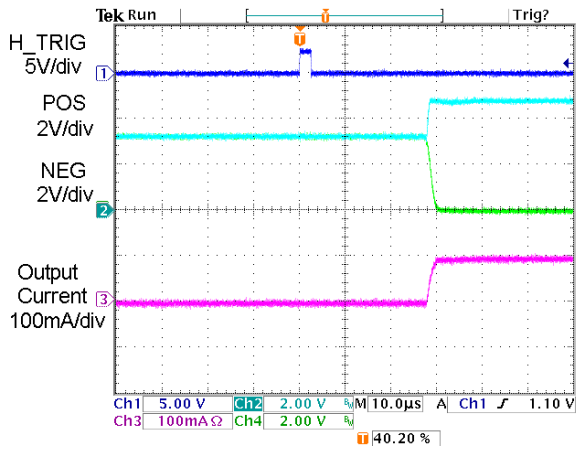

Figure 3. Haptic Power-Up Response (T_{TRIG_R}) (100 mA resistive load)

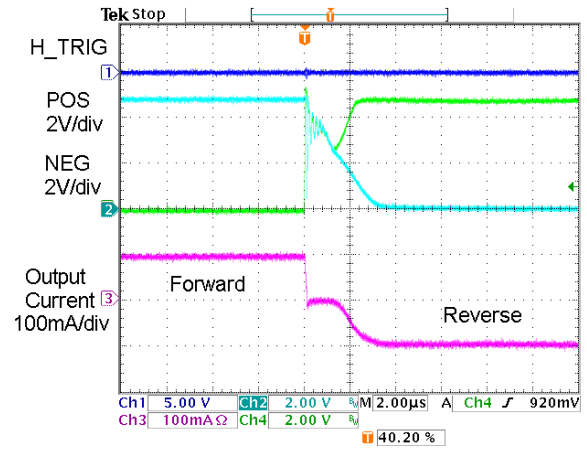

Figure 4. Haptic Forward-Reverse Transition (100 mA resistive load)

CAT3211

Table 5. I²C TIMING CHARACTERISTICS

(Typical values: VIN = 5.0 V, RST = Logic High, T_{AMB} = 25°C unless otherwise specified.) (Note 6)

Symbol	Parameter	Min	Typ	Max	Unit
f _{SCL}	Interface Clock Frequency (Note 6)			400	kHz
t _{AA}	SCL Low to SDA Data Out and ACK Out			0.9	μs
t _{BUF}	Bus Free Time Before a New Transmission Can Start	1.2			μs
t _{HD:STA}	Start Condition Hold Time	0.6			μs
t _{LOW}	Clock Low Period	1.2			μs
t _{HIGH}	Clock High Period	0.6			μs
t _{SU:STA}	Start Condition Setup Time (For a Repeated Condition)	0.6			μs
t _{HD:DAT}	Data In Hold Time	0			ns
t _{SU:DAT}	Data In Setup Time	100			ns
t _R	SDA and SCL Rise Time (Note 6)			0.3	μs
t _F	SDA and SCL Fall Time (Note 6)			300	ns
t _{SU:STO}	Stop Condition Setup Time	0.6			μs
t _{DH}	Data Out Hold Time	50			ns

6. Limits guaranteed by design and statistical analysis.

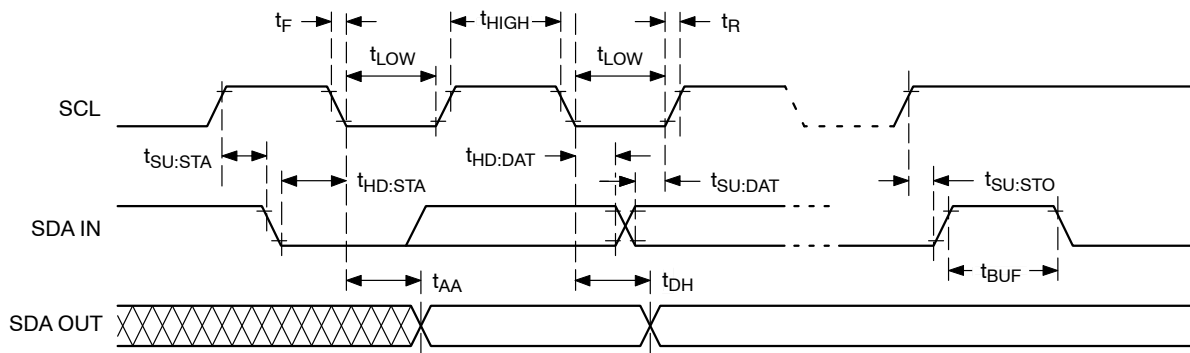

Figure 5. I²C Bus Timing Characteristics

CAT3211

TYPICAL CHARACTERISTICS

VIN = 5 V, T_{AMB} = 25°C, RST = Logic High. Rotary vibrator motor connected between the POS and NEG pins.
 Typical application circuit (Figure 1) unless otherwise noted.

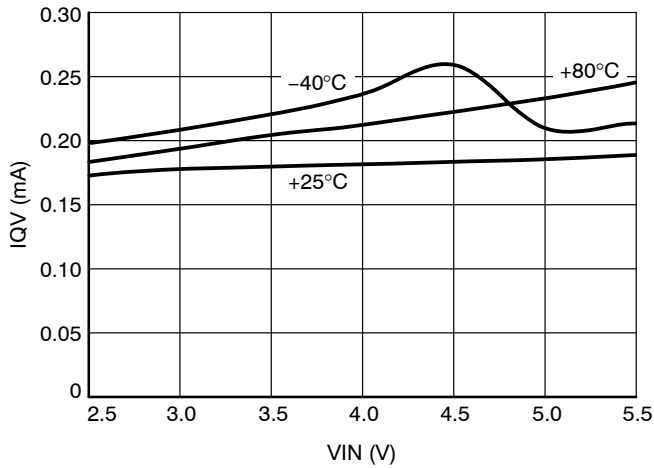

Figure 6. Operating Current (Vibrator mode, no load)

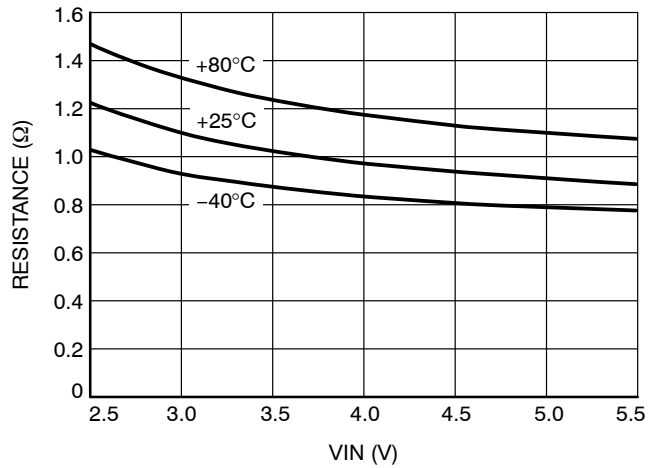

Figure 7. Switch Resistance (100 mA load)

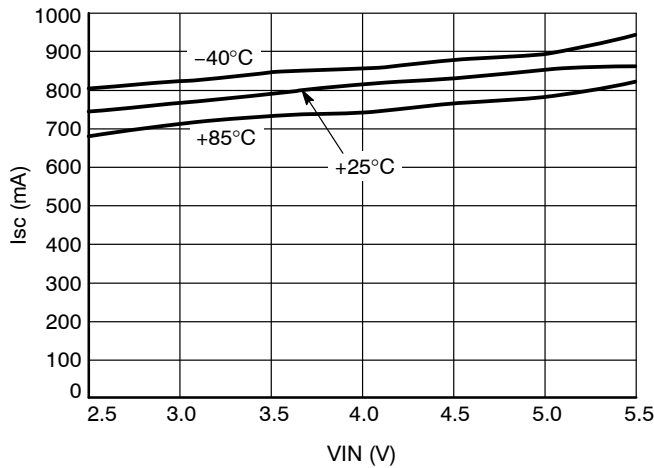

Figure 8. Output Short Circuit Current Limit

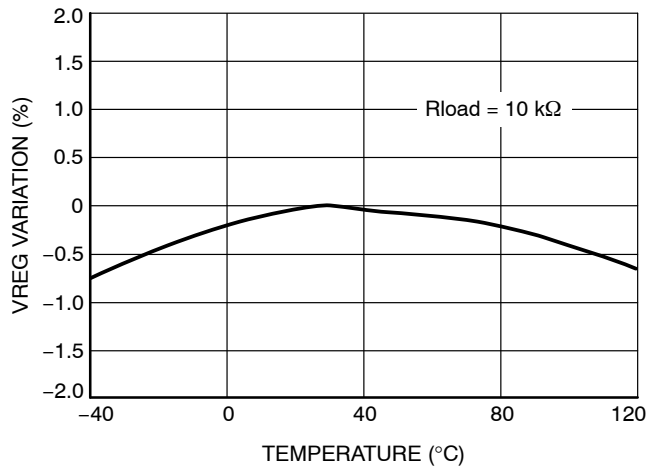

Figure 9. VREG vs. Temp. (Vibrate, VREG = 2.5 V)

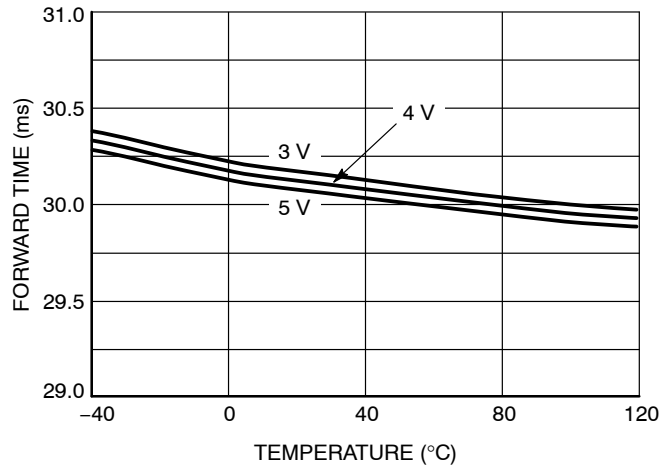

Figure 10. Forward Time (Haptic, 30 ms)

CAT3211

TYPICAL CHARACTERISTICS

VIN = 5 V, T_{AMB} = 25°C, RST = Logic High. Rotary vibrator motor connected between the POS and NEG pins.
Typical application circuit (Figure 1) unless otherwise noted.

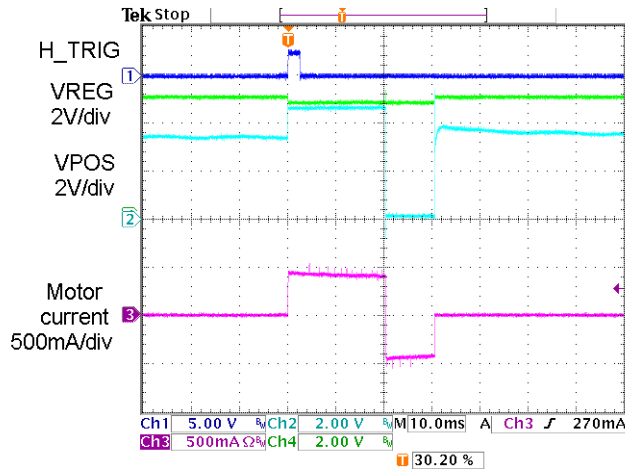

Figure 11. Haptic Forward/Reverse Pulse (10 Ω motor)

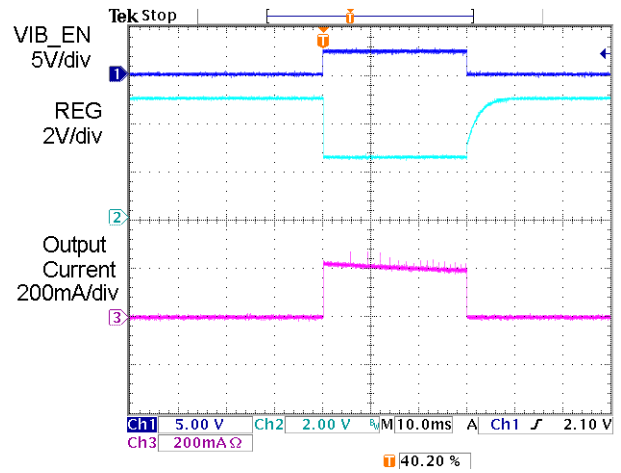

Figure 12. Vibrate Transition (10 Ω motor)

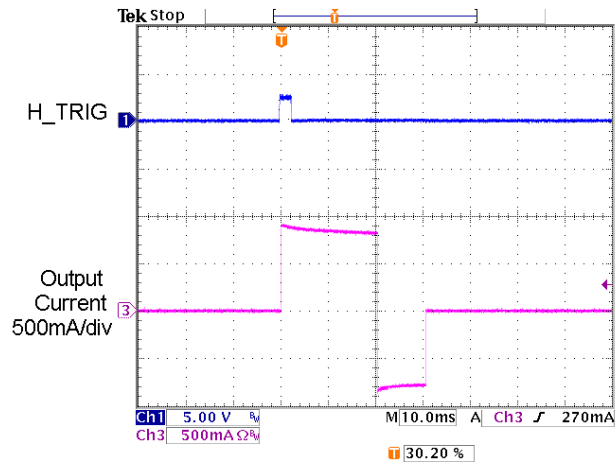

Figure 13. Output Short Circuit Operation

Table 6. PIN DESCRIPTION

Pin No	Name	Function
1	$\overline{\text{RST}}$	Device reset active low input.
2	SDA	I ² C bidirectional data input/output, open-drain.
3	SCL	I ² C clock input.
4	VIN	Supply input.
5	NEG	Connect to negative side of motor
6	PGND	Ground reference for the H-Bridge.
7	POS	Connect to positive side of motor.
8	REG	Connected to the internal LDO output.
9	OSC	External oscillator input (optional).
10	H_TRIG	External Haptic mode trigger input.
11	VIB_EN	External Vibrate mode enable input.
12	GND	Ground Reference for the device logic.

PIN FUNCTION

VIN is the supply voltage input pin for the device. A small 1 μF ceramic bypass capacitor is required in close proximity across the VIN pin and the GND pin. The normal operating supply voltage range is from 2.7 V to 5.5 V. An internal under-voltage lock-out (UVLO) circuit will disable the output drive current whenever the supply voltage falls below approximately 2.0 V. The driver should not be operated for a supply VIN below 2 V. If the supply dropped below 2.0 V and VIN is restored, the device should be re-programmed to the desired register setting.

VIB_EN is the vibrate enable logic input pin used to enable the vibrate mode. The applied voltage levels required for logic high and logic low are 1.4 V and 0.4 V respectively. This allows direct connection to low voltage processors. An internal pull-down resistor of 110 k Ω exists between the VIB_EN pin and GND. When both VIB_EN and H_TRIG are low, the device enters a standby mode. When the VIB_EN pin is taken high, the H-Bridge turns on the output in forward mode where the POS pin is connected to REG (and the NEG pin to PGND). In order to protect from overdriving the motor, the internal LDO regulates the H-Bridge between VIN and 2 V according to the LDOV register. If the $\overline{\text{RST}}$ or CHIP_EN bit in the CONFIG register are low then VIB_EN input is ignored.

H_TRIG is the haptic logic input pin to trigger the haptic pulse sequence. The applied voltage levels required for logic high and logic low are 1.4 V and 0.4 V respectively. This allows direct connection to low voltage processors. An internal pull-down resistor of 110 k Ω exists between the H_TRIG pin and GND. When both VIB_EN and H_TRIG are low, the device enters a standby mode. On H_TRIG rising edge, the H-bridge is activated with the following haptic mode sequence: forward (POS connected to REG, NEG connected to PGND), coast (both POS and NEG disconnected), and reverse (POS connected to PGND, NEG

connected to REG). The haptic pulse timing is stored in the two registers HAPTIC_A and HAPTIC_B. A recovery timer prevents retriggering the haptic sequence until the recovery time is over. The recovery timer can be configured between 0 and 60 clock cycles according to the HAPTIC_B register. The H_Bridge input voltage can be adjusted to ‘fine tune’ the overdrive voltage by setting the internal LDO regulator voltage using the LDOH register. If H_TRIG is triggered while VIB_EN is high, then H_TRIG overrides and sets off a haptic timer sequence. Once the haptic sequence is finished, the device returns to normal VIB_EN mode (forward direction and LDOV setting voltage). If the $\overline{\text{RST}}$ or CHIP_EN bit in the CONFIG register are low, the H_TRIG input is ignored.

POS is the positive output node of the internal H-bridge. During normal operation, this pin has a drive resistance of approx 0.4 Ω to either REG (LDO output) or to PGND, depending on the direction being selected. The maximum sourcing or sinking current at this pin is current limited to 850 mA typical. When the coast timer starts, the POS pin immediately enters a high-impedance state. During any forward/reverse transitions, the POS drive output exhibits a break-before-make interval of approximately 2 μs , eliminating any shoot-through current spikes. Internal clamping diodes on the POS pin safely dissipate any inductive load current spikes back into PGND or REG nodes.

NEG is the negative output node of the internal H-bridge. During normal operation, this pin has a drive resistance of 0.4 Ω to either PGND or to REG (LDO output), depending on the direction being selected. The maximum sinking or sourcing current at this pin is current limited to 850 mA typical. When the coast timer starts, the NEG pin immediately enters a high-impedance state. During any forward/reverse transitions, the NEG drive output exhibits a break-before-make interval of approximately 2 μs ,

eliminating any shoot-through current spikes. Internal clamping diodes on the NEG pin safely dissipate any inductive load current spikes back into PGND or REG nodes.

REG is the LDO regulated output which is connected to the input of the H-bridge. A small 1 μ F ceramic bypass capacitor is required in close proximity across the REG pin and the PGND pin. The LDO output voltage setting is stored in the LDOH or LDOV registers depending on the mode selected, haptic or vibrate respectively. The LDO regulator prevents the motor from being overdriven by reducing the amplitude of the voltage applied to the H-bridge and thus the motor.

OSC is the external oscillator logic input pin. The haptic timer clock can be selected from the internal oscillator (1 ms time base with $\pm 20\%$ accuracy) or from an external oscillator if a higher precision is required. The optional external oscillator is connected to the OSC pin. Selection of the external oscillator is done by setting the OSC register EXT_OSC bit (B0) high (1). The external and internal oscillator frequency can be divided from 0 to 128 times via bits B1, B2 & B3 in the OSC register. When the internal oscillator is used, the OSC pin can be left unconnected. When EXT_OSC bit is high, an internal watchdog monitors the OSC pin signal. In haptic mode, if the OSC pin rising-edge to rising-edge duration is longer than the watchdog timeout (8 ms typical) then the haptic sequence is aborted to prevent any motor damage.

SDA is the I²C serial data line, open-drain requiring an external pull-up resistor as defined in the I²C standard. This is a bidirectional data line allowing data to be written and read from the registers. The voltage levels required for logic high and logic low are 1.4 V and 0.4 V respectively. This allows the interface to be directly connected to low voltage processors.

SCL is the I²C serial clock input. The voltage levels required for logic high and logic low are 1.4 V and 0.4 V respectively. This allows the interface to be directly connected to low voltage processors.

RST is the reset active low input logic pin. When the pin is driven low, it resets all the internal registers to their default values and shuts down the device. Once the $\overline{\text{RST}}$ input returns to a logic high, the device is enabled again. The voltage levels required for logic high and logic low are 1.4 V and 0.4 V respectively.

Since the device has no power-on reset logic, it is recommended that after power-up, the $\overline{\text{RST}}$ is set low for a short time in order to reset all the registers.

GND is the ground reference for the input logic pins. The pin must be connected to the ground plane on the PCB.

PGND is the ground reference for the H-bridge switches. This pin carries the return current flowing through the H-bridge via the POS and NEG pins and must be connected to the ground plane.

Table 7. MODE SELECTION TRUTH TABLE

$\overline{\text{RST}}$ (Pin)	CHIP_EN (Reg)	VIB_EN (Reg or Pin)	H_TRIG (Reg or Pin)	H_REPT (Reg)	REG PIN SETTING	Operation Mode
0	X	X	X	X	OFF : WEAK PULLUP VIN	Device Shutdown (VIB_EN & H_TRIG no operation). No I ² C interface programming possible.
1	0	X	X	X	OFF : WEAK PULLUP VIN	Device Standby (VIB_EN & H_TRIG no operation). I ² C Interface programming possible
1	1	0	0	0	OFF : WEAK PULLUP VIN	Device Standby (Awaiting signal from VIB_EN or H_TRIG).
1	1	0	1 \uparrow	0	LDOH Register Setting	Haptic mode sequence triggered on rising H_TRIG edge.
1	1	1	0	0	LDOV Register Setting	Vibrate mode enabled on VIB_EN logic high.
1	1	1	1 \uparrow	0	LDOH Register Setting	Haptic mode triggered. Once Haptic sequence completes, device returns to vibrate mode (REG = LDOV) until next haptic rising edge.
1	1	X	X	1	LDOH Register Setting	Haptic mode repeat enabled. Haptic sequence will continuously repeat programmed sequence. Ensure recovery time is correctly programmed to prevent motor damage.

NOTE: X = DON'T CARE (Can be Logic High or Logic Low)

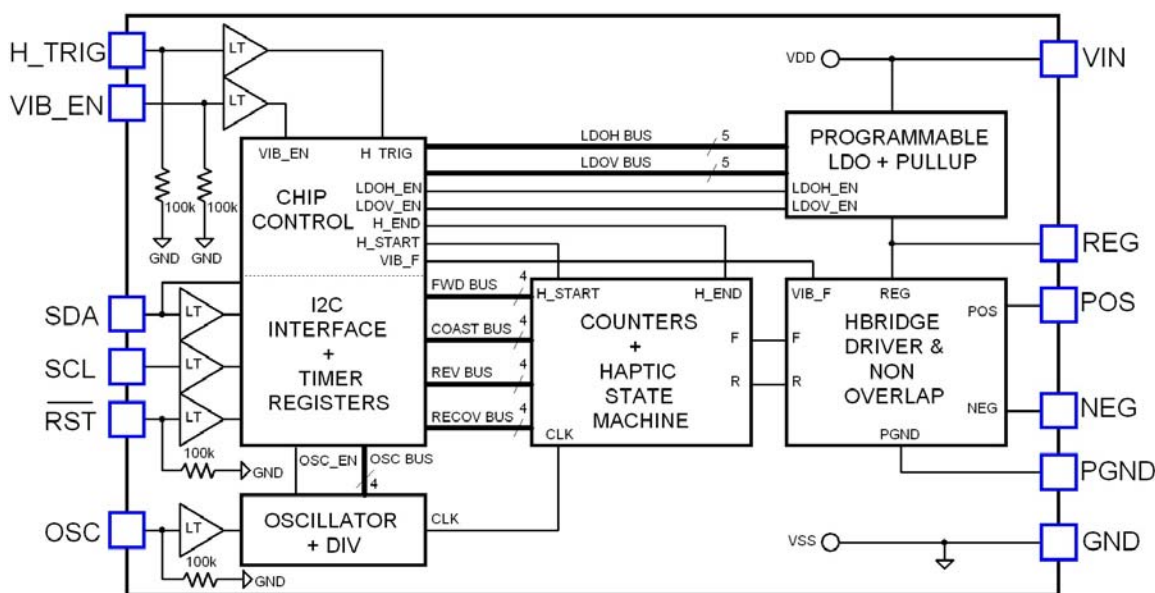

Figure 14. Simplified Block Diagram

BASIC OPERATION

The CAT3211 contains six 8-bit registers controlled via the I²C interface. On power-up, these registers are set to their default values and can be modified to store the haptic pulse timing durations, the oscillator configuration settings, and the H-bridge regulator voltage levels in both haptic or vibrate modes.

The internal haptic sequence generator is triggered on the rising edge of H_TRIG. This allows direct connection from a touch screen controller bypassing the CPU and improving latency time from key-press to mechanical user feedback. During the haptic mode, the voltage supply to the H-Bridge can be programmed from 2.0 V to 5.0 V or shorted to VIN via the LDOH register. This allows the motor to be safely overdriven for short durations, greatly increasing the user experience.

The device can be configured to drive the motor for a standard incoming call by driving VIB_EN high. This mode can be driven safely for extended times since the LDO regulated voltage to rotary motor can be programmed at safe voltage levels via LDOV register.

The device can be fully shut down via the I²C interface to prevent external systems from triggering or enabling any modes by writing a zero into the CONFIG register CHIP_EN bit (B0).

Haptic Mode Timers

The internal oscillator for the haptic mode timers are selected by writing a zero into the OSC register EXT_OSC bit. Writing a one into the EXT_OSC bit allows an external oscillator to be used via OSC pin. The internal and external clock can be further divided from 1 time to 128 times by

setting OSC_DIV_2, OSC_DIV_4 and OSC_DIV16 accordingly.

The haptic pulse timers are configured via the HAPTIC_A and HAPTIC_B registers. Forward, Coast and Reverse timers can be configured from 0 to 30 clock cycles in 2 cycle increments. The Recovery timer can be configured from 0 to 60 clock cycles in 4 cycle increments. In order to prevent the motor from being overdriven in haptic mode for extended times, it is not possible to start a new haptic pulse unless the recovery time has elapsed.

Protection

The device includes over-current protection on all H-bridge switches to protect the POS and NEG pins from damage and stops the VIN supply from dipping due to excessive currents during fault conditions.

The device is designed to handle the inductive currents in the rotor windings during direction transitions or power off conditions without affecting operation of the device. A 1 μ F capacitor is required between REG and PGND to absorb these current spikes.

In case the die temperature exceeds the thermal shutdown temperature (T_{SD}) of 140°C typical, the CONFIG register TEMP_L bit (B3) is set to one automatically and permanently (latched) until \overline{RST} goes low. This information can be retrieved by the system by reading the CONFIG register at a later time. The TEMP_L bit is read-only.

Thermal shutdown and under-voltage lockout disable the device if abnormal conditions are detected and dynamically enable once the abnormal condition is removed.

CAT3211

Table 8. REGISTER MAP

ADD NAME	ADDR	DEFAULT	B7	B6	B5	B4	B3	B2	B1	B0
CONFIG	00h	01h	X	X	X	H_REPT	TEMP_L	VIB_EN	H_TRIG	CHIP_EN
OSC	01h	00h	X	X	X	X	OSC_DIV_16	OSC_DIV_4	OSC_DIV_2	EXT_OSC
HAPTIC_A	02h	0Ah	COAST_TIMER[3:0]				FORWARD_TIMER[3:0]			
HAPTIC_B	03h	85h	RECOVERY_TIMER[3:0]				REVERSE_TIMER[3:0]			
LDOH	04h	00h	X	X	X	V_LDO_HAPTIC[4:0]				
LDOV	05h	1Ah	X	X	X	V_LDO_VIBRATOR[4:0]				

The default register setting after the device power-up is the following.

- Register bit CHIP_EN high in standby mode. OSC is internally set for a clock cycle of 1 ms duration.

- Haptic mode default: Forward time = 20 ms, Coast time = 0 ms, Reverse time = 10 ms, Recovery time = 32 ms.
- Haptic mode default: LDO output set to VIN. Vibrate mode default LDO output set to 2.5 V.

Table 9. CONFIG & OSC REGISTER BIT MAP

BIT SETTING	CHIP_EN	H_TRIG	VIB_EN	TEMP_L	H_REPT	EXT_OSC	OSC_DIV_2	OSC_DIV_4	OSC_DIV_16
0	Device Standby	Disabled (Logic OR with pin H_TRIG)	Disabled (Logic OR with pin VIB_EN)	Temp OK	Disabled	Internal Oscillator Selected	OSC Div 2 OFF	OSC Div 4 OFF	OSC Div 16 OFF
1	Device Enabled	Haptic On (Rising edge triggered)	Vibrator mode enabled	Over Temp Detected (Latched)	Haptic sequence repeat	External Oscillator Selected	OSC Div 2 ON	OSC Div 4 ON	OSC Div 16 ON

Table 10. HAPTIC_A & HAPTIC_B REGISTER TIMER BIT MAP

HEX[3:0]	BINARY	FORWARD_TIMER	COAST_TIMER	REVERSE_TIMER	RECOVERY_TIMER
0	0000	0	0 *	0	0
1	0001	OSC x 2	OSC x 2	OSC x 2	OSC x 4
2	0010	OSC x 4	OSC x 4	OSC x 4	OSC x 8
3	0011	OSC x 6	OSC x 6	OSC x 6	OSC x 12
4	0100	OSC x 8	OSC x 8	OSC x 8	OSC x 16
5	0101	OSC x 10	OSC x 10	OSC x 10 *	OSC x 20
6	0110	OSC x 12	OSC x 12	OSC x 12	OSC x 24
7	0111	OSC x 14	OSC x 14	OSC x 14	OSC x 28
8	1000	OSC x 16	OSC x 16	OSC x 16	OSC x 32 *
9	1001	OSC x 18	OSC x 18	OSC x 18	OSC x 36
A	1010	OSC x 20 *	OSC x 20	OSC x 20	OSC x 40
B	1011	OSC x 22	OSC x 22	OSC x 22	OSC x 44
C	1100	OSC x 24	OSC x 24	OSC x 24	OSC x 48
D	1101	OSC x 26	OSC x 26	OSC x 26	OSC x 52
E	1110	OSC x 28	OSC x 28	OSC x 28	OSC x 56
F	1111	OSC x 30	OSC x 30	OSC x 30	OSC x 60

* Default values

Table 11. LDOH & LDOV REGISTER VOLTAGE BIT MAP (Note 7)

HEX[4:0]	BINARY	V_LDO_X	HEX[4:0]	BINARY	V_LDO_X
00	00000	REG = VIN *	10	10000	3.5
01	00001	5.0	11	10001	3.4
02	00010	4.9	12	10010	3.3
03	00011	4.8	13	10011	3.2
04	00100	4.7	14	10100	3.1
05	00101	4.6	15	10101	3.0
06	00110	4.5	16	10110	2.9
07	00111	4.4	17	10111	2.8
08	01000	4.3	18	11000	2.7
09	01001	4.2	19	11001	2.6
0A	01010	4.1	1A	11010	2.5 *
0B	01011	4.0	1B	11011	2.4
0C	01100	3.9	1C	11100	2.3
0D	01101	3.8	1D	11101	2.2
0E	01110	3.7	1E	11110	2.1
0F	01111	3.6	1F	11111	2.0

7. V_LDO_X voltage setting or VIN, the lesser of the two. * default values.

I²C Interface

A 2-wire serial I²C-bus interfaces with the motor driver in order to program, read or write, its six registers. The SDA and SCL lines comply with the I²C electrical specification and should be terminated with external pull-up resistors. When the bus is not used, both lines are high. The device supports the maximum bus speed of 400 kbit/s. The serial bit sequence is shown below for read and write operations into

the registers. Read and write instructions are initiated by the master controller/CPU and acknowledged by the slave motor driver. The I²C address of the driver is internally fixed to the binary value 1100110. The protocol requires that the start bit and the device address are both repeated. For further details on the I²C protocol, please refer to the I²C-Bus Specification, document number 9398 393 40011, from Philips Semiconductors.

Read Register Operation:



Write Register Operation:



- S: Start condition
- R: Read bit is 1
- W: Write bit is 0
- A: Acknowledge sent by the slave motor driver (SDA low)
- A*: Not Acknowledge sent by the master microcontroller (SDA high)
- P: Stop condition
- Slave address: Device address 7 bits (MSB first, slave address is 1100110).
- Register address: Device register address 8 bits
- Data: Data to read or write 8 bits

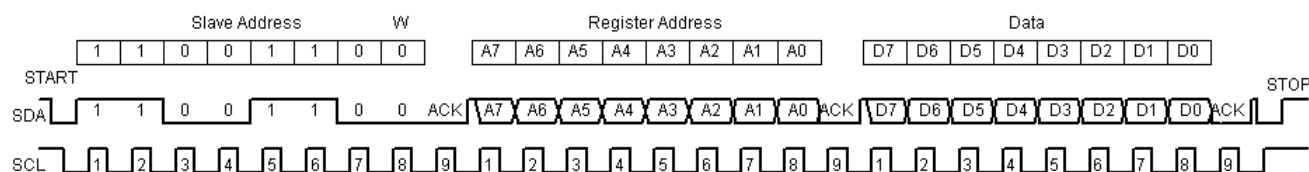

Figure 15. Write Instruction Sequence

CAT3211

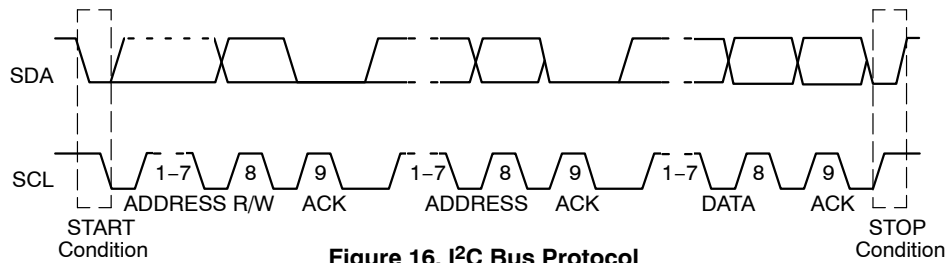

Figure 16. I²C Bus Protocol

APPLICATION INFORMATION

Motor Drive

The CAT3211 can drive an external DC motor also referred to as Eccentric Rotating Mass (ERM) in haptics applications. With the H-bridge configuration, motors can be driven in the forward direction (with VIB_EN pin high) and in forward/reverse direction (H_TRIG edge triggered). Figure 17 shows the H-bridge block diagram and the current path for the forward motor direction. The four integrated diodes across each switch MOSFET allow for commutation of large current of inductive motor load without using external diodes. The driver response time is 40 μs typical after H_TRIG or VIB_EN becomes active. A vibration kick can be produced by reversing the motor spin direction to produce a sharp transient and stop the motor quickly. Due to the internal H-bridge low on-resistance, the POS and NEG terminals provide a near rail-to-rail voltage swing (due to small I · R drop) which maximizes the output

drive. When programming the LDO to a lower output voltage (REG), the motor is further protected from being overdriven. The H-bridge internal switch current limit I_{SC} prevents the current into the motor from exceeding 850 mA typical. Depending on the motor resistance, the maximum current can be set up to 600 mA minimum.

The motor armature DC resistance (R_M) sets the maximum current according to the formula below:

$$I_L = \frac{(V_{POS} - V_{NEG})}{R_M}$$

External Component

The CAT3211 requires a small 1 μF bypass ceramic capacitor connected directly between VIN pin and GND pin, and a 1 μF between REG pin and PGND pin as shown in Figure 17.

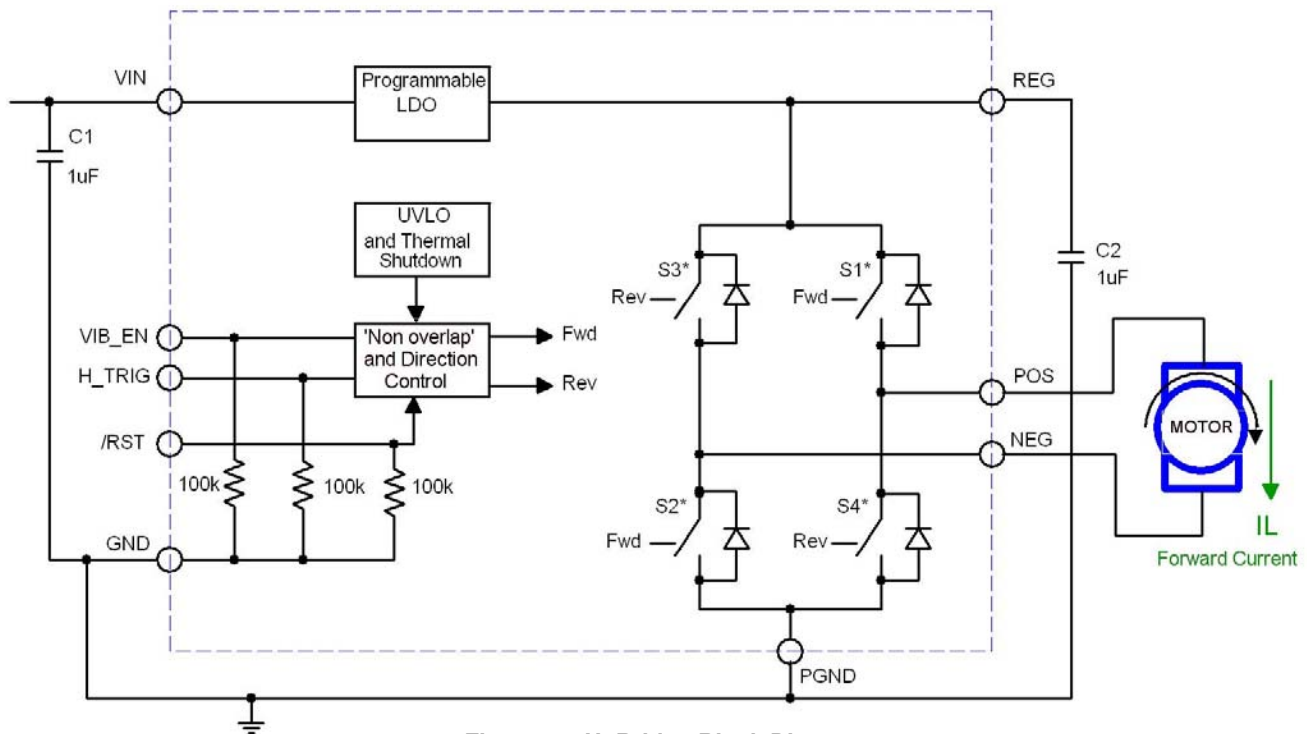

Figure 17. H-Bridge Block Diagram

MECHANICAL CASE OUTLINE

PACKAGE DIMENSIONS

ON Semiconductor®



UQFN12 1.7x2.0, 0.4P
CASE 523AE-01
ISSUE A

DATE 11 JUN 2007

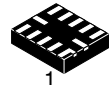

SCALE 4:1

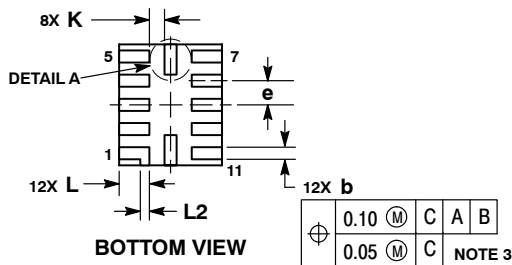
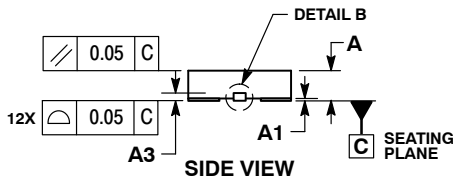
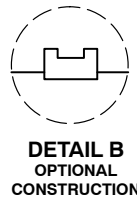
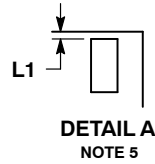
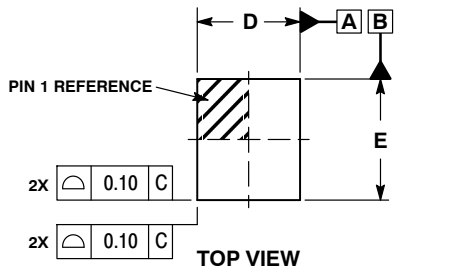

NOTES:

1. DIMENSIONING AND TOLERANCING PER ASME Y14.5M, 1994.
2. CONTROLLING DIMENSION: MILLIMETERS
3. DIMENSION b APPLIES TO PLATED TERMINAL AND IS MEASURED BETWEEN 0.15 AND 0.30 MM FROM TERMINAL TIP.
4. MOLD FLASH ALLOWED ON TERMINALS ALONG EDGE OF PACKAGE. FLASH 0.03 MAX ON BOTTOM SURFACE OF TERMINALS.
5. DETAIL A SHOWS OPTIONAL CONSTRUCTION FOR TERMINALS.

DIM	MILLIMETERS	
	MIN	MAX
A	0.45	0.55
A1	0.00	0.05
A3	0.127 REF	
b	0.15	0.25
D	1.70 BSC	
E	2.00 BSC	
e	0.40 BSC	
K	0.20	---
L	0.45	0.55
L1	0.00	0.03
L2	0.15 REF	

GENERIC MARKING DIAGRAM*

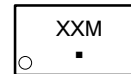

- XX = Specific Device Code
- M = Date Code
- = Pb-Free Package

*This information is generic. Please refer to device data sheet for actual part marking. Pb-Free indicator, "G" or microdot "▪", may or may not be present.

MOUNTING FOOTPRINT SOLDERMASK DEFINED

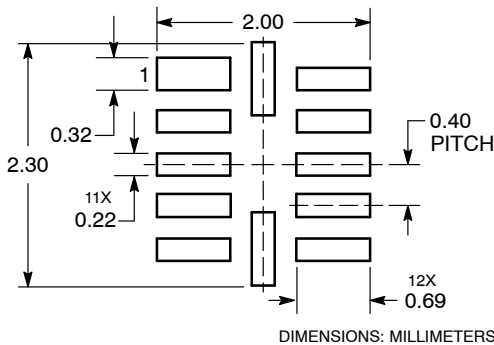

DOCUMENT NUMBER:	98AON23418D	Electronic versions are uncontrolled except when accessed directly from the Document Repository. Printed versions are uncontrolled except when stamped "CONTROLLED COPY" in red.
DESCRIPTION:	UQFN12 1.7 X 2.0, 0.4P	PAGE 1 OF 1

ON Semiconductor and ON are trademarks of Semiconductor Components Industries, LLC dba ON Semiconductor or its subsidiaries in the United States and/or other countries. ON Semiconductor reserves the right to make changes without further notice to any products herein. ON Semiconductor makes no warranty, representation or guarantee regarding the suitability of its products for any particular purpose, nor does ON Semiconductor assume any liability arising out of the application or use of any product or circuit, and specifically disclaims any and all liability, including without limitation special, consequential or incidental damages. ON Semiconductor does not convey any license under its patent rights nor the rights of others.

ON Semiconductor and  are trademarks of Semiconductor Components Industries, LLC dba ON Semiconductor or its subsidiaries in the United States and/or other countries. ON Semiconductor owns the rights to a number of patents, trademarks, copyrights, trade secrets, and other intellectual property. A listing of ON Semiconductor's product/patent coverage may be accessed at www.onsemi.com/site/pdf/Patent-Marking.pdf. ON Semiconductor reserves the right to make changes without further notice to any products herein. ON Semiconductor makes no warranty, representation or guarantee regarding the suitability of its products for any particular purpose, nor does ON Semiconductor assume any liability arising out of the application or use of any product or circuit, and specifically disclaims any and all liability, including without limitation special, consequential or incidental damages. Buyer is responsible for its products and applications using ON Semiconductor products, including compliance with all laws, regulations and safety requirements or standards, regardless of any support or applications information provided by ON Semiconductor. "Typical" parameters which may be provided in ON Semiconductor data sheets and/or specifications can and do vary in different applications and actual performance may vary over time. All operating parameters, including "Typicals" must be validated for each customer application by customer's technical experts. ON Semiconductor does not convey any license under its patent rights nor the rights of others. ON Semiconductor products are not designed, intended, or authorized for use as a critical component in life support systems or any FDA Class 3 medical devices or medical devices with a same or similar classification in a foreign jurisdiction or any devices intended for implantation in the human body. Should Buyer purchase or use ON Semiconductor products for any such unintended or unauthorized application, Buyer shall indemnify and hold ON Semiconductor and its officers, employees, subsidiaries, affiliates, and distributors harmless against all claims, costs, damages, and expenses, and reasonable attorney fees arising out of, directly or indirectly, any claim of personal injury or death associated with such unintended or unauthorized use, even if such claim alleges that ON Semiconductor was negligent regarding the design or manufacture of the part. ON Semiconductor is an Equal Opportunity/Affirmative Action Employer. This literature is subject to all applicable copyright laws and is not for resale in any manner.

PUBLICATION ORDERING INFORMATION

LITERATURE FULFILLMENT:

Email Requests to: orderlit@onsemi.com

ON Semiconductor Website: www.onsemi.com

TECHNICAL SUPPORT

North American Technical Support:
Voice Mail: 1 800-282-9855 Toll Free USA/Canada
Phone: 011 421 33 790 2910

Europe, Middle East and Africa Technical Support:

Phone: 00421 33 790 2910

For additional information, please contact your local Sales Representative

