

Class 1

EV Charge Inlet Combo 2



Content

1. SCOPE	3
1.1. Content.....	3
1.2. Processing Note	3
2. APPLICABLE DOCUMENTS	4
2.1. TE Connectivity Documents.....	4
2.2. General Documentation	5
3. APPLICATION TOOLS	6
4. WIRES	6
4.1. Assessment of the wires	6
4.2. Wire selection	6
4.3. Wire preparation.....	6
5. REQUIREMENTS ON THE CRIMPED CONTACT WITH W-CRIMP SHAPE (CLOSED BARREL)	7
5.1. Conductor position	7
5.2. Crimp Geometry	7
5.3. Cross Sections	8
5.4. Wire pull-out forces	8
5.5. Crimp Position.....	9
5.6. Contact area.....	9
5.7. Sealing area	9
5.8. Shape and position tolerances.....	10
5.9. Measuring equipment and measuring position	10
6. REQUIREMENTS ON THE CRIMPED CONTACT WITH F-CRIMP SHAPE	11
7. ASSEMBLY INSTRUCTIONS	12
7.1. Assembly overview Charge Inlet Combo2.....	12
7.2.1 Parts to order for 12V Actuator variants	14
7.3 Assembly Configurations Cable Exit	16
7.4 Kits to order.....	16
7.5 Security Advice / Sicherheitshinweis.....	17
7.6 Assembly Steps.....	19
7.7 End of Line Test	37

1. SCOPE

1.1. Content

This specification describes the assembly and handling of the vehicle charge inlets of combined charging system Type2 (CCS2) compatible with configuration FF of IEC62196-3 for conductive charging of electric vehicles with AC current and DC current for fast charging. This specification applies to manual assembly of the components in series production configuration.

This specification though recommends an optimal way for assemble the charge inlet assuring the required performance of the product, it does not exclude other alternative way of assemblies or verification steps (excluding international standard bonded) based on harness maker's know-how when required product performance guaranteed.

1.2. Processing Note

The processor is responsible for the quality of the manufacturing process to ensure the correct function of the system. The warranty and liability are excluded if quality deficiency or damages occur due to noncompliance to this specification or use of not specified or not released tools, cables and components.

2. APPLICABLE DOCUMENTS

The following technical documents, if referred to, are part of this specification. In case of a contradiction between this specification and the product drawing or this specification and the specified documentation, the product specification has priority.

2.1. TE Connectivity Documents

a) Customer drawings for inlet type Combo 2

CHARGE INLET KIT. COMBO 2, 90 DEGREE	2375502
INLET HSG, COMBO 2, ASSY	2377400-1
DIA 6MM, PIN TERMINAL, AC 6SQMM	2293269-3
DIA 6MM, PIN TERMINAL, PE 25SQMM	2293270-5
PROTECTION CAP CHARGE INLETS	2292534-1
SEALING	2120571-1
DIA 8MM, PIN TERMINAL	2306177-1
CABLE EXIT, RECT, COMBO, LEFT	1-2303200-1
CABLE EXIT, RECT, COMBO RIGHT	1-2303200-2
FAMILY SEAL, AC	1-2350592-5
STRAIN RELIEF, AC	2367140-1
COVER, CABLE SEAL, AC	2296057-2
FAMILY SEAL, COMBO DC	2366539-1
COVER, CABLE SEAL, COMBO DC	2366667-1
MQS BLINDSTOPFEN	963143-1
FLAP, ASSY, INLET COMBO 2, LEFT	2358664-2
FLAP, ASSY, INLET COMBO 2, RIGHT	2358664-4

b) Specifications / Spezifikationen

108-94804	Product Spec. Vehicle Charge Inlets Combo 2
114-13000	Application Specification Micro Mate-N-Lock Connectors
108-94519	Product Specification Vehicle Charge Inlet Actuator GEN 2

2.2. General Documentation

Cable Specifications of Prescribed Cables

TE Connectivity advice to do not use Polyvinyl chloride, Polyurethane or Polyolefin insulated cables as they do not comply with the general LV214 requirement. Due to low performance of cable insulation after heat exposure, it can cause leakage issues during the lifetime because of low compression set between cables and seals.

Alternative cables except listed below and other than Silicone Rubber insulated being used in this application are not permitted without prior validation by TE Connectivity and consideration of the general risk on water tightness is obligatory where TE Connectivity is not accountable.

AC-cable: cross-section 4 x 6,0mm²

Supplier	Coroplast
Outer Diameter	15,1 -0,5 mm
Min. bending radius	3xD (static)
Cable description	<i>FHLR2G2GCB2G 4x6.0mm² similar LV216-2 class F (T200) TPJLR.18.007, Issue 3</i>
Supplier Part No.:	9-2641 (4x6mm ²)

DC-HV-Cable : Cross-section 1 x 70mm²

Supplier :	HUBER+SUHNER
Outer Diameter	17.0±0.3 mm
Cable description:	<i>FHLR4GC13X-1x70 T150</i>
Part No.:	84100298

PE-cable: cross-section 25mm²

Supplier	HUBER+SUHNER
Outer Diameter	8.20mm ±0.20 mm
Cable description	AUTOL 155 25MM2P GNYE
Supplier Part No.:	85066283

Signal-cable: cross-section 0,5mm²

Supplier	Several
Outer Diameter	1.6-0.2 mm
Cable description	<i>FLRY-0.5 A</i>
Supplier Part No.:	515274

3. APPLICATION TOOLS

To produce a correct wire crimp, as validated by TE with the wires listed in this specification, following application tools are required.

Wire Size [mm ²]	Stripping Length single wire for crimp [mm]	Crimp /WELD height CH ₁ [mm]	Cable Specification	Supplier	Contact P/N	Geo-metry	Applicator	TE Crimp Validation is based on crimp press stroke / cycle time
0.5	3.2 ± 0.1	0.89 ± 0.05	FLRY-A 0.5mm ²	SEVERAL	0-794606-1	F	2151022-1	G-Terminator PN 354500-1 Cycle Time:<500ms
6	13,0 ± 1	3,7 ± 0,1	FHLR2G2GCB2 G 4x6.0mm ²	COROPLAST	2293269-3	W	7-528041-9	Hanke 971-200. Cycle time: 1.7 - 2.5s Stroke: 44mm
25	18,0 ± 1	6.3±0.1	AUTOL 155 25MM2P GNYE 25mm ²	HUBER & SUHNER	2293270-5		2276149-6	
70	Right 19,0±1,0 Left 28,0 ±1,0	9,3±0,15	Radox ELASTOMER 70mm ²	HUBER & SUHNER	2306177-1	F	541915-2	-

Table 1

Crimp Die Sets are subject to wear and their condition and quality have to be monitored. Suspect and/or worn Die Sets have not to be used for the production of these crimps. Die Sets are available as spare parts.

4. WIRES

4.1. Assessment of the wires

To ensure the required electrical crimp contactability with stable crimp resistance a permissible maximum storage period of 8 months for unprocessed cable (referring to cable manufacturer production date) has to be respected.

4.2. Wire selection

The contact system is released for the application with wires specified in chapter 2.2
The released contact-wire-combinations and crimp parameters are given in table 1.

Other wires require the validation and approval of the TE engineering department.
The wires are applied as single wire terminations. Double terminations are not intended.

4.3. Wire preparation

The cable has to be cut accurately with a 90 deg angle.

The cable insulation must be stripped before crimping. The stripping length of the outer insulation and shield is defined in the following Assembly Steps.

The insulation must be cut accurately and pulled off from the conductor. Offcut of insulation must not remain on the conductor. Single strands may not be damaged, fanned out, cut or pulled out. Furthermore, the operator should avoid touching the bare single strands and the strands shall not be twisted. All single strands need to be caught in the crimp and not a single strand must remain outside the crimp.

5. REQUIREMENTS ON THE CRIMPED CONTACT WITH W-CRIMP SHAPE (CLOSED BARREL)

The following terms shown below are used in this specification, see figure 1.

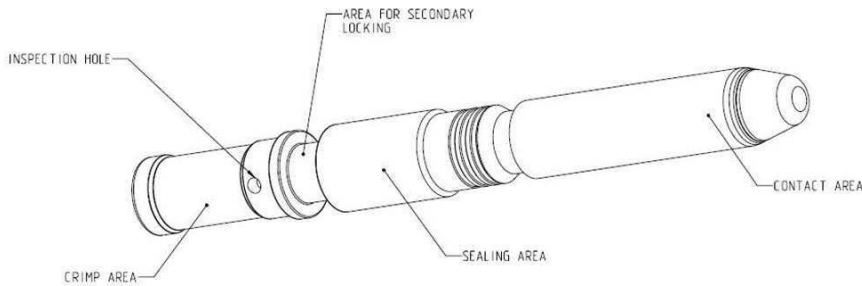

Figure 1

5.1. Conductor position

The single strands of the conductor are clamped inside the crimp area. All single strands need to be caught in the crimp and not a single strand must remain outside the crimp. The wire end must be fully inserted into the crimp area and has to be checked via the inspection hole after crimping. Insulation must not be inside of the crimping area, see figure 2

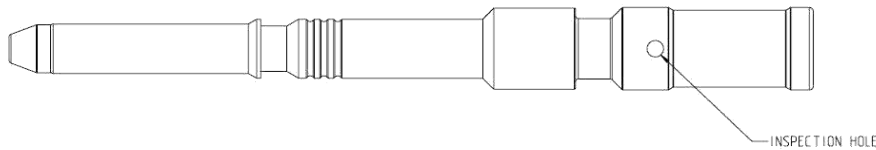

Figure 2

5.2. Crimp Geometry

The crimp geometry, crimp heights including their corresponding tolerances as well as wire sizes are given in table 1.

The crimp height is the key quality feature of a crimp connection. The measurement allows a non-destructing examination and a continuous process inspection. It is provided for every wire size and contact. The crimp height is given in table 2.

Crimp height and width may also be measured in a cross-section image. The mechanical operated measurement though is preferred.

During the application process the crimp height must be checked. This is valid for each batch and after every change or switchover of contact reel or wire bundle or applicator respective it's setup or components.

The crimp height has to be measured over both extensions in middle of the crimp, figure 3:



Figure 3 (picture exemplarily)

5.3. Cross Sections

When creating cross-sections, the correct grinding layer must be selected. The Grinding layer had to be at middle of crimp area and may not be inside of serration, see figure 4.

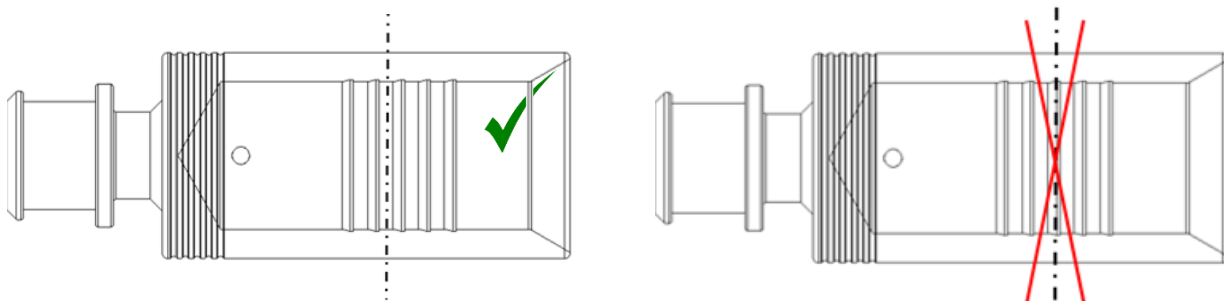

Figure 4 (picture exemplarily)

5.4. Wire pull-out forces

Measurement of wire pull-out forces from the wire crimp is a supporting manufacturing control.

The pull-out forces must fulfil the requirements according product specification 108-94778

5.5. Crimp Position

The TE applicator positions the contacts in the crimping tool at middle position as shown, figure 5 and 6. Correct position and condition of applicator has to be checked for every production lot.

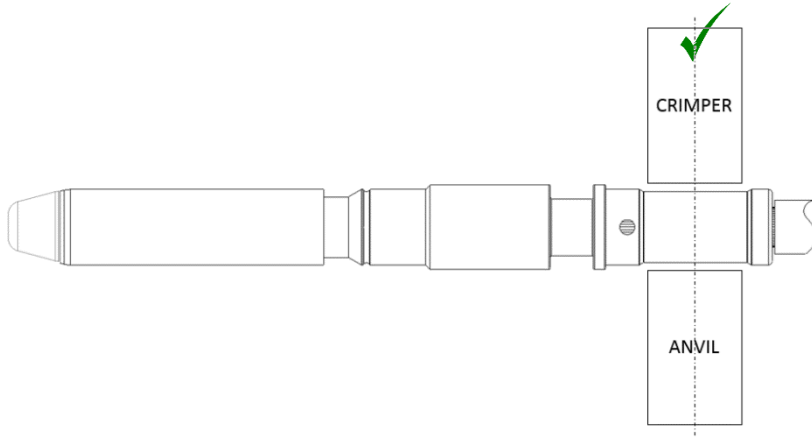

Figure 5 (picture exemplarily)

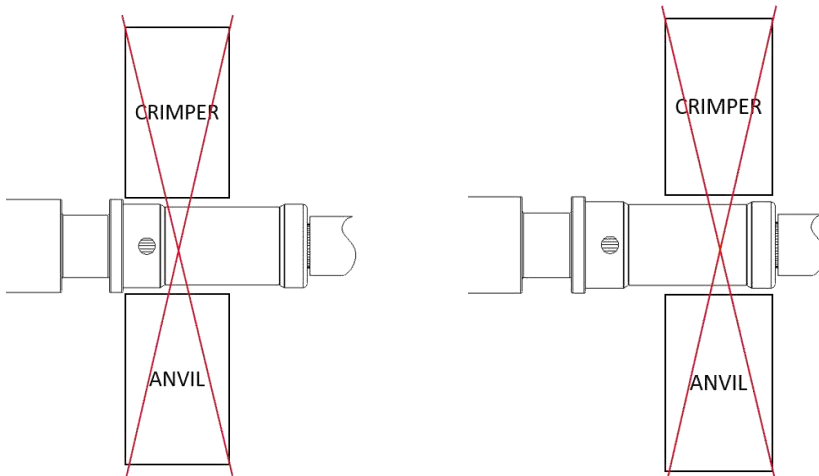

Figure 6 (picture exemplarily)

5.6. Contact area

During processing and following processing, the contact area may not be damaged or bended.

5.7. Sealing area

During processing and following processing, the sealing area may not be damaged or bended

5.8. Shape and position tolerances

Measuring the shape and position deviation is not always necessary, if the contact is obviously straight by eye. In case a measurement is required, the measurement equipment required at least a 10-time better measuring precision compared with the requirement tolerances, see figure 7 and 8.

Meeting the specific shape and position tolerances must be ensured before the contact is inserted into the housing.

If contacts are bent during the application process and exceed the specified tolerances these must not be bent back or reworked but must be scrapped.

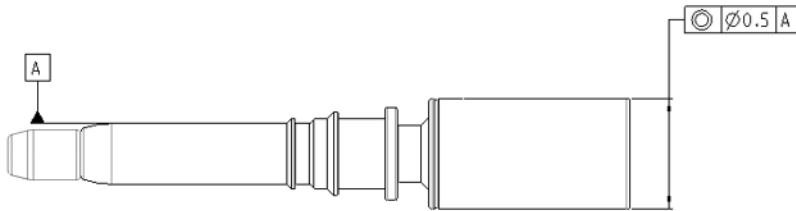

Figure 7 (picture exemplarily)

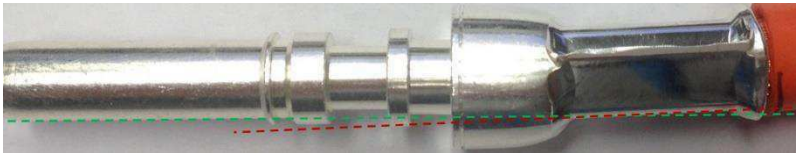

Figure 8 (picture exemplarily)

5.9. Measuring equipment and measuring position

As measuring equipment for measuring crimp height, a digital caliper with accuracy of measuring 0.01mm is the minimum requirement. Measuring of crimp height had to be done according as following always in middle of crimp area across whole crimp, see figure 9 and figure 3.



Figure 9 (picture exemplarily)

6. REQUIREMENTS ON THE CRIMPED CONTACT WITH F-CRIMP SHAPE

The crimp of the 70mm² cables on 90 DEG DC power contacts with F-shaped crimp geometry has to be processed according to Application Specification 114-94436.

7. ASSEMBLY INSTRUCTIONS

7.1. Assembly overview Charge Inlet Combo2

Charge Inlet Combo 2 Left 90Degree Kit

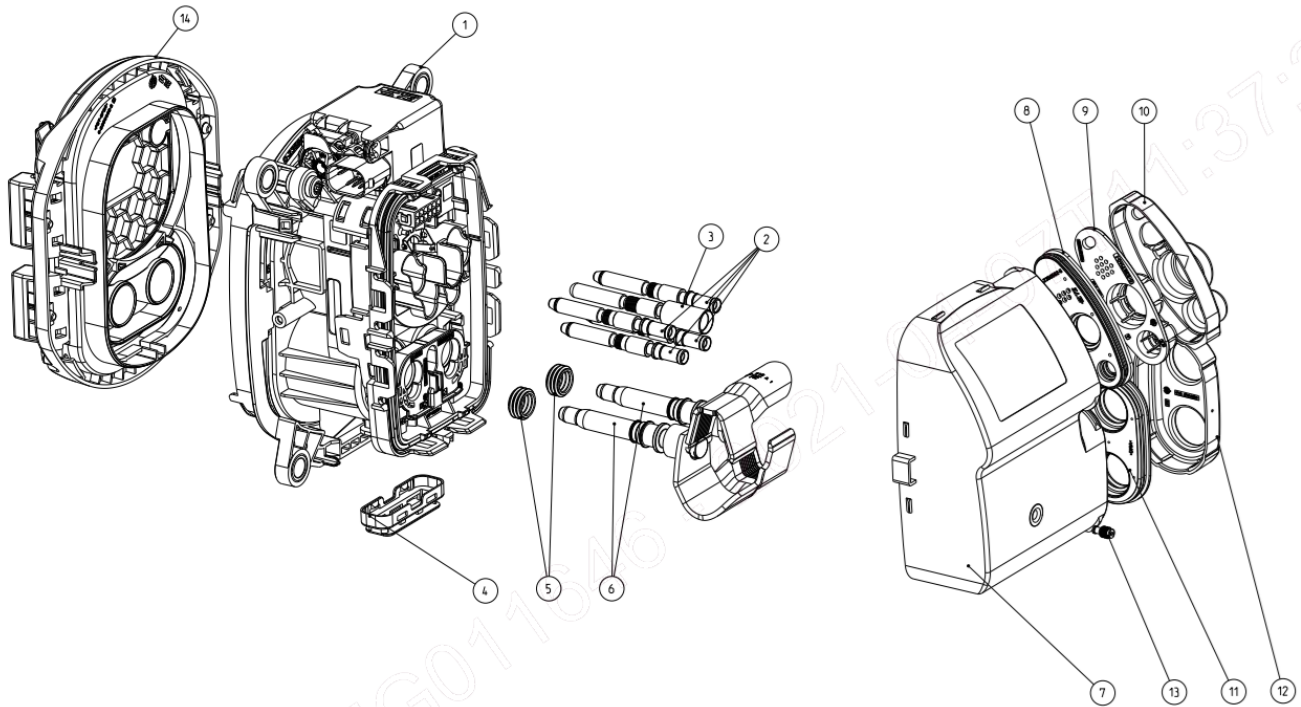

Figure 10

NO FLAP
CABLE EXIT LEFT
Keine Klappeneinheit
Kabelausgang Links
0-2375502-1

FLAP OPEN LEFT
CABLE EXIT LEFT
Öffnung der Klappeneinheit nach links
Kabelausgang Links
0-2375502-3

FLAP OPEN RIGHT
CABLE EXIT LEFT
Öffnung der Klappeneinheit nach rechts
Kabelausgang Links
0-2375502-5

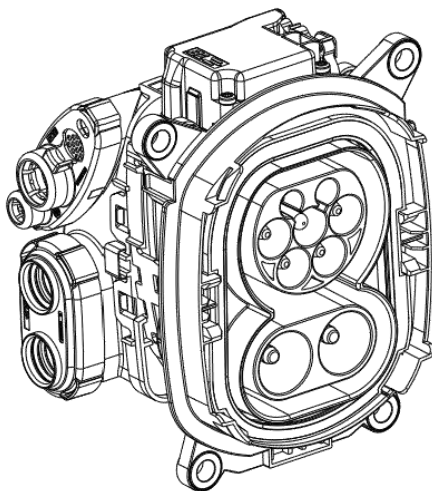

Figure 10a

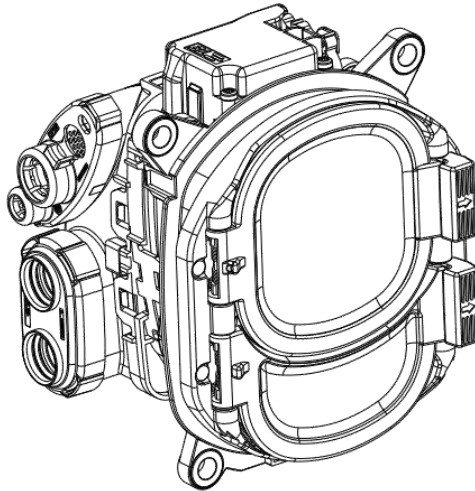

Figure 10b

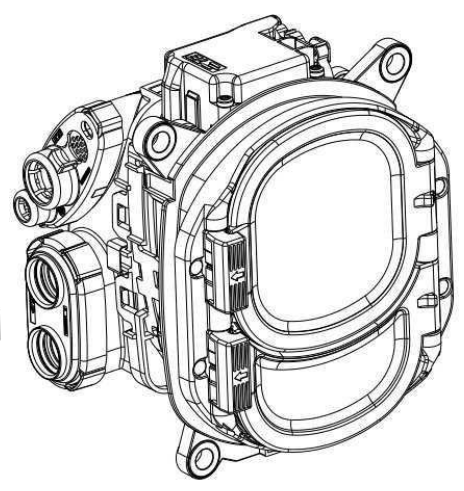

Figure 10c

Charge Inlet Combo 2 Right 90Degree Kit

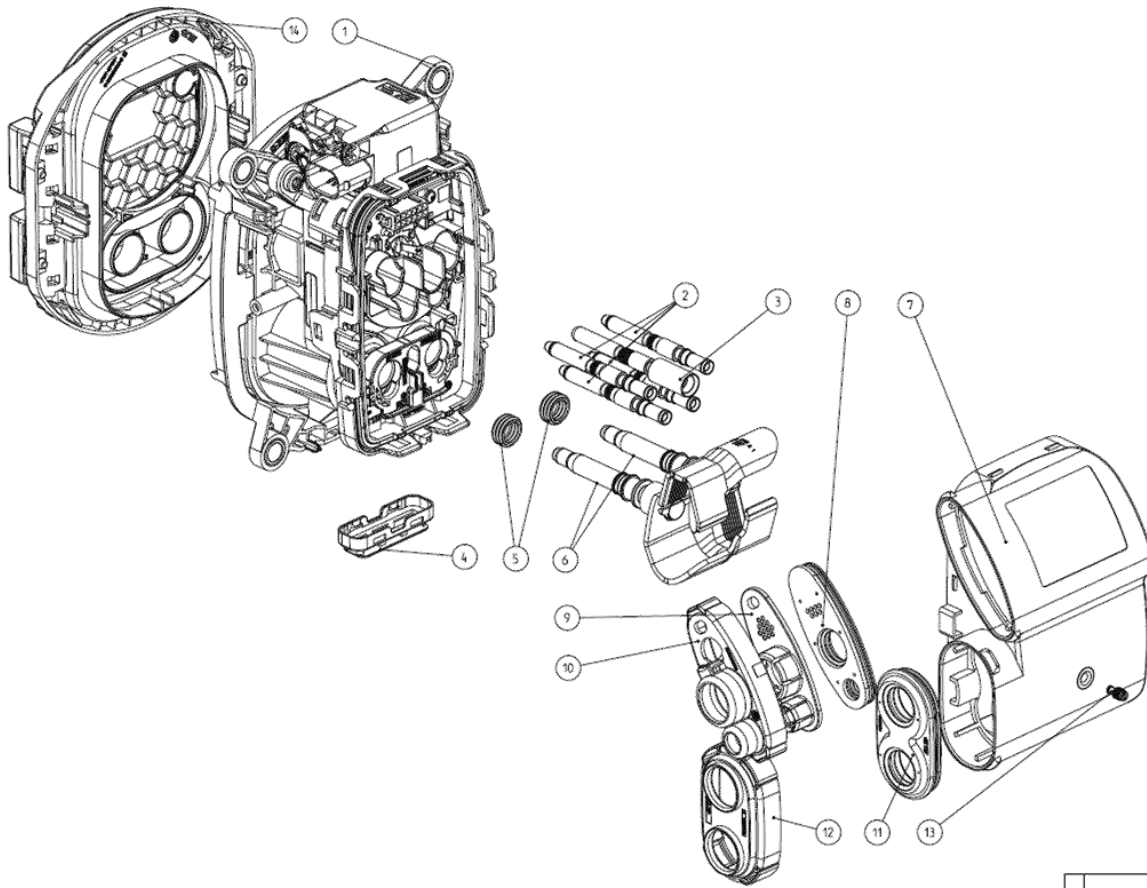

Figure 11

NO FLAP
CABLE EXIT RIGHT
Keine Klappeneinheit
Kabelausgang rechts
0-2375502-2

FLAP OPEN LEFT
CABLE EXIT RIGHT
Öffnung der Klappeneinheit nach Links
Kabelausgang rechts
0-2375502-4

FLAP OPEN RIGHT
CABLE EXIT RIGHT
Öffnung der Klappeneinheit nach rechts
Kabelausgang rechts
0-2375502-6

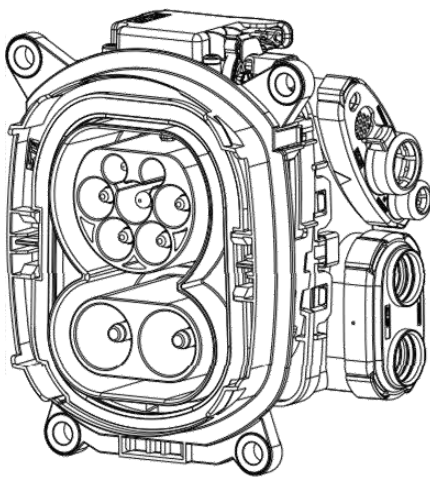

Figure 11a

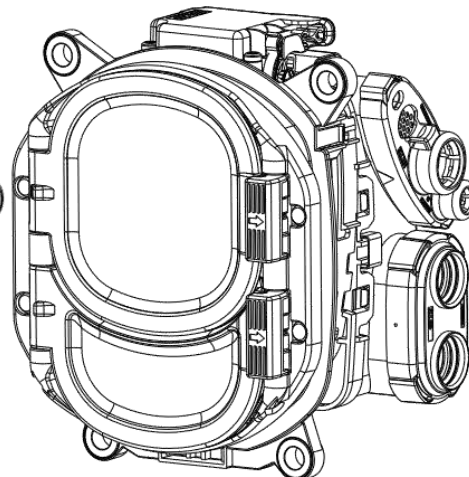

Figure 11b

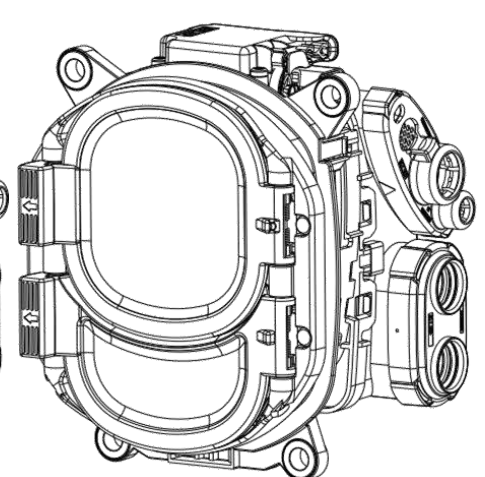

Figure 11c

7.2.1 Parts to order for 12V Actuator variants

Charge Inlet Combo 2 90 Degree			Charge Inlet Left Without Flap Unit	Charge Inlet Right Without Flap Unit
Part		Variant	3-phase AC 6mm ² Ground 25mm ² DC 70mm ²	3-phase AC 6mm ² Ground 25mm ² DC 70mm ²
Pos	Qty.	Name / Bezeichnung	P/N	P/N
1	1	INLET HSG, COMBO2, ASSY	2377400-1	2377400-1
-	1	12P MICRO MNL HSG (Additional part for charge inlet cabling)	1-794617-2	1-794617-2
	7	CONTACT MICRO MNL (0.5mm ²) (Additional part for charge inlet cabling)	0-794606-1	0-794606-1
2	4	PIN DIA 6.0, RIGID, POWER AC, ASSY (6mm ²)	2293269-3	2293269-3
3	1	PIN DIA 6.0, RIDIG, PE (25mm ²)	2293270-5	2293270-5
4	1	PROTECTION CAP, TE, WATER DRAIN	2292534-1	2292534-1
5	2	SEALING	2120571-1	2120571-1
6	2	PIN DIA 8.0, 90 DEG, CONTACT, ASSY TYP 2, (70mm ²)	2306177-1	2306177-1
7	1	CABLE EXIT DC SIDE, COMBO	1-2303200-1	1-2303200-2
8	1	FAMILY SEAL, AC (PE 25mm ² , AC 4x 6mm ² , Signal 11x 0.35mm ² or 0,5mm ²)	1-2350592-5	1-2350592-5
9	1	STRAIN RELIEF, AC	2367140-1	2367140-1
10	1	COVER, CABLE SEAL, AC	2296057-2	2296057-2
11	1	FAMILY SEAL, COMBO DC (70mm ²)	2366539-1	2366539-1
12	1	COVER, CABLE SEAL, DC	2366667-1	2366667-1
13	1	MQS CAVITY PLUG FOR CENTERLINE 4 MM	963143-1	963143-1
-	-	4POS MQS Connector HSG, Seals and Contacts (Additional part for charge inlet cabling)	p/n acc. Prod. Spec. 108-94519	p/n acc. Prod. Spec. 108-94519
-	1	Optional: FLAP, SLIM COMBO 2, ASSY (left)	2358664-2	
-	1	Optional: FLAP, SLIM COMBO 2, ASSY (right)	2358664-4	

Table 2

7.2.2 Parts to order for 24V Actuator variants

Charge Inlet Combo 2 90 Degree			Charge Inlet Left Without Flap Unit	Charge Inlet Right Without Flap Unit
Part			3-phase AC 6mm ² Ground 25mm ² DC 70mm ²	3-phase AC 6mm ² Ground 25mm ² DC 70mm ²
Pos	Qty.	Name / Bezeichnung	P/N	P/N
1	1	INLET HSG, COMBO2, ASSY	2377400-3	2377400-3
-	1	12P MICRO MNL HSG (Additional part for charge inlet cabling)	1-794617-2	1-794617-2
-	7	CONTACT MICRO MNL (0.5mm ²) (Additional part for charge inlet cabling)	0-794606-1	0-794606-1
2	4	PIN DIA 6.0, RIGID, POWER AC, ASSY (6mm ²)	2293269-3	2293269-3
3	1	PIN DIA 6.0, RIDIG, PE (25mm ²)	2293270-5	2293270-5
4	1	PROTECTION CAP, TE, WATER DRAIN	2292534-1	2292534-1
5	2	SEALING	2120571-1	2120571-1
6	2	PIN DIA 8.0, 90 DEG, CONTACT, ASSY TYP 2, (70mm ²)	2306177-1	2306177-1
7	1	CABLE EXIT DC SIDE, COMBO	1-2303200-1	1-2303200-2
8	1	FAMILY SEAL, AC (PE 25mm ² , AC 4x 6mm ² , Signal 11x 0.35mm ² or 0,5mm ²)	1-2350592-5	1-2350592-5
9	1	STRAIN RELIEF, AC	2367140-1	2367140-1
10	1	COVER, CABLE SEAL, AC	2296057-2	2296057-2
11	1	FAMILY SEAL, COMBO DC (70mm ²)	2366539-1	2366539-1
12	1	COVER, CABLE SEAL, DC	2366667-1	2366667-1
13	1	MQS CAVITY PLUG FOR CENTERLINE 4 MM	963143-1	963143-1
-	-	4POS MQS Connector HSG, Seals and Contacts (Additional part for charge inlet cabling)	p/n acc. Prod. Spec. 108-94519	p/n acc. Prod. Spec. 108-94519
-	1	Optional: FLAP, SLIM COMBO 2, ASSY (left)	2358664-2	
-	1	Optional: FLAP, SLIM COMBO 2, ASSY (right)	2358664-4	

Table 3

7.3 Assembly Configurations Cable Exit

The inlet is designed for alternative cable exit directions to the left or right. These configurations are shown in figure 12 and 12a. The definition is according to view from the Charging Inlet front.

To the left side

To the right side

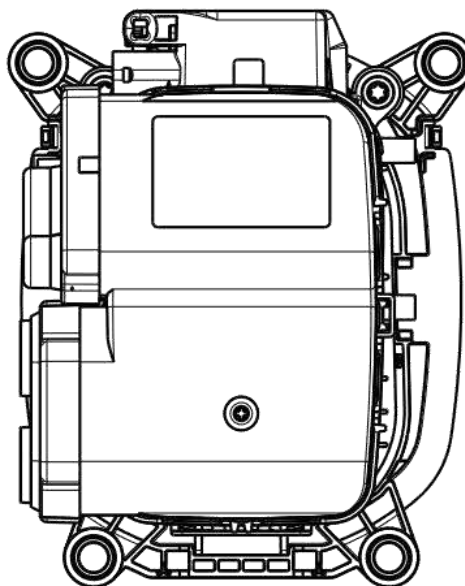
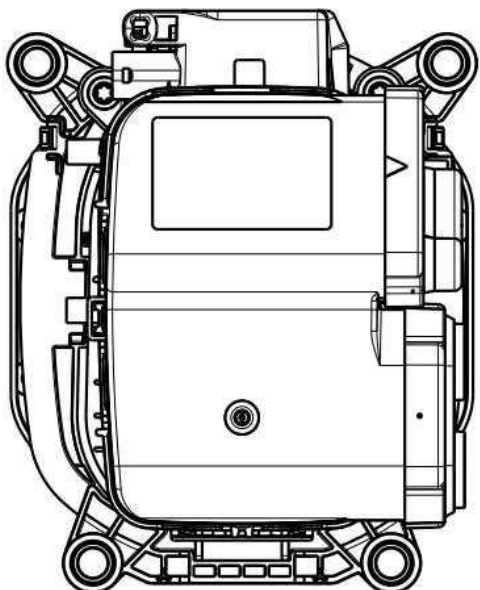

Figure 12

Figure 12a

7.4 Kits to order

Sets optional including Flap Unit Assembly

Additional parts according to table 2 above must be considered for Charge Inlet cabling!

See Figure 10 and 11.

PN 0-2375502-1 No Flap Unit Cable Exit left 12V Actuator	PN 0-2375502-2 No Flap Unit Cable Exit right 12V Actuator	PN 0-2375502-3 Flap open left Cable Exit left 12V Actuator	PN 0-2375502-4 Flap open left Cable Exit right 12V Actuator	PN 0-2375502-5 Flap open right Cable Exit left 12V Actuator	PN 0-2375502-6 Flap open right Cable Exit right 12V Actuator
PN 1-2375502-1 No Flap Unit Cable Exit left 24V Actuator	PN 1-2375502-2 No Flap Unit Cable Exit right 24V Actuator	PN 1-2375502-3 Flap open left Cable Exit left 24V Actuator	PN 1-2375502-4 Flap open left Cable Exit right 24V Actuator	PN 1-2375502-5 Flap open right Cable Exit left 24V Actuator	PN 1-2375502-6 Flap open right Cable Exit right 24V Actuator

Table 4

7.5 Security Advice / Sicherheitshinweis

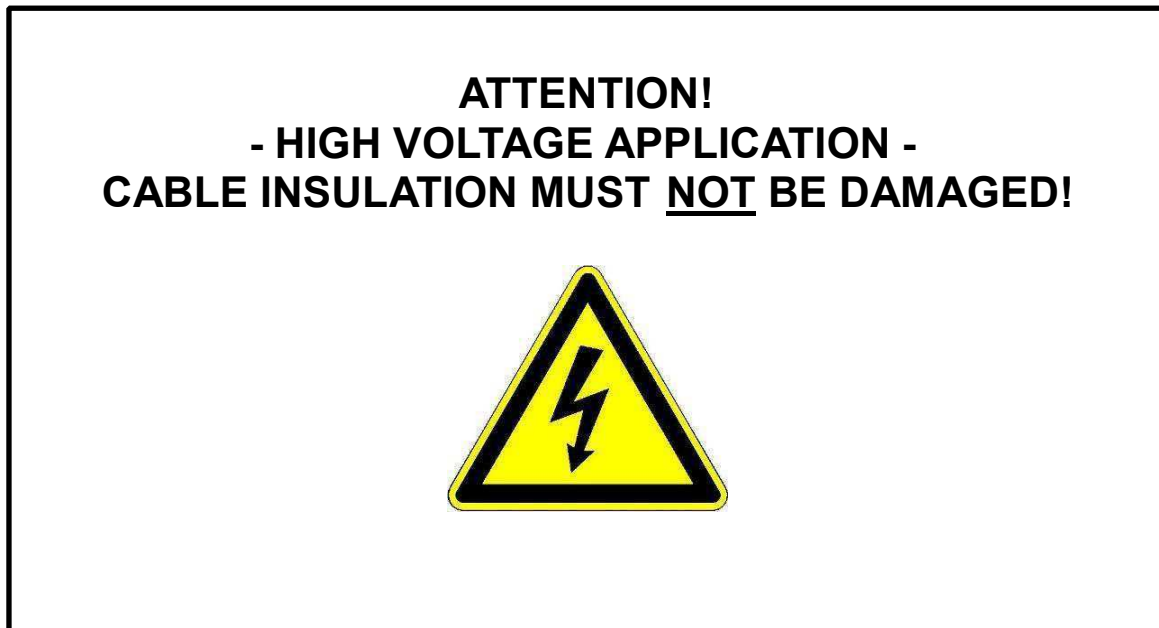

The assembly has only be performed by trained personnel.

Avoid prolonged or repeated skin contact with silver plated contacts (wear protective gloves)!

ATTENTION!
ESD SAFETY REQUIRED!

**THE PRINTED CIRCUIT BOARDS ARE STATIC SENSITIVE
DEVICES, WHICH CAN BE DAMAGED IF TOUCHED WITHOUT THE
NECESSARY ELECTROSTATIC DISCHARGE PRECAUTIONS!
DURING HANDLING OF THE OPENED INLET ASSEMBLY ESD
SAFETY IS REQUIRED!**



7.6 Assembly Steps

Step 1

The COVER CABLE SEAL AC 2296057-2, STRAIN RELIEF AC 2367140-1 and FAMILY SEAL AC 1-2350592-5 must be pushed over the signal wires, the ground wire and the AC-Multicore wire. Pay attention to place all wires at correct positions, figure 13. Especially ensure the correct position of the flange of the Lshaped FAMILY SEAL AC towards the STRAIN RELIEF, figure 13a

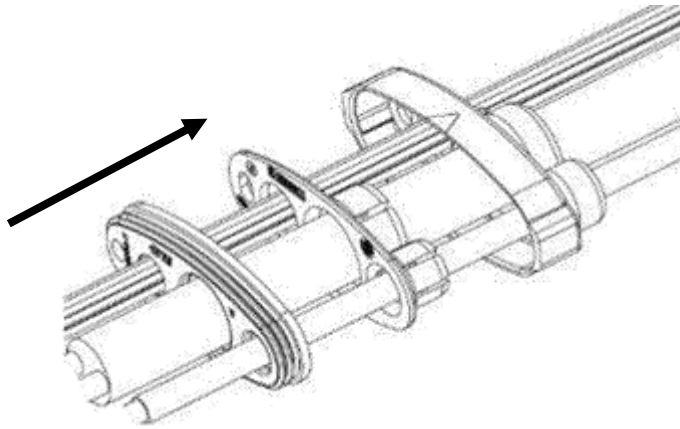

Figure 13

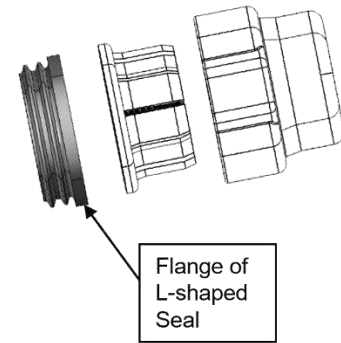

Figure 13a

Step 2

Dismantle the wires and crimp the contacts: **4x6 mm² AC-Multicore Cable**

Remove outer insulation, shield and filler of AC-multicore-cable acc. figure 14 and table 4.

The given length of the single wires ensures that the outer sheath of the multicore cable seals to the FAMILY SEAL AC 1-2350592-5. Alternatively, a marking on the outer sheath in a certain distance to the cut off position can be used to ensure the proper position of the outer sheath in the FAMILY SEAL AC.

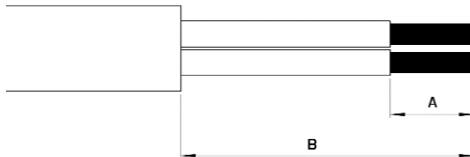

Figure 14 (schematic view)

Wire Size	Removal of insulation dim. "A"	Length of single wires "B"
6 mm ²	13 mm +/- 1mm	68 +/-2 mm

Table 5

Crimp the conductors to the PIN DIA6,0 RIGID CONTACTS 2293269-3 with the specified tools listed in table 1. The crimp has to fulfil the requirements acc. Chapter 5.

Step 3

Dismantle the wires and crimp the contact: **25 mm² PE (ground) single wire**

Remove outer insulation acc. Figure 15 and table 5.

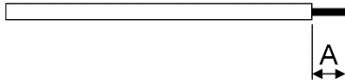

Figure 15

Wire Size	Removal of insulation dim. "A"
25 mm ²	18 mm +/- 1mm

Table 6

Crimp the conductors to the PIN DIA 6,0 RIGID CONTACT 2293270-5 with the specified tools listed in table 1. The crimp has to fulfill the requirements acc. Chapter 5.

Step 4

Dismantle the wires and crimp the contacts: **Signal-Wires 0,5mm²**

Dismantle single wires acc. spec. 114-13000 and crimp the contacts 0-794606-1 acc. spec. 114-13000, see figure 16.



Figure 16

After Crimping the different cables, the subassembly of cables with cable exit components is in the condition shown in figure 17:

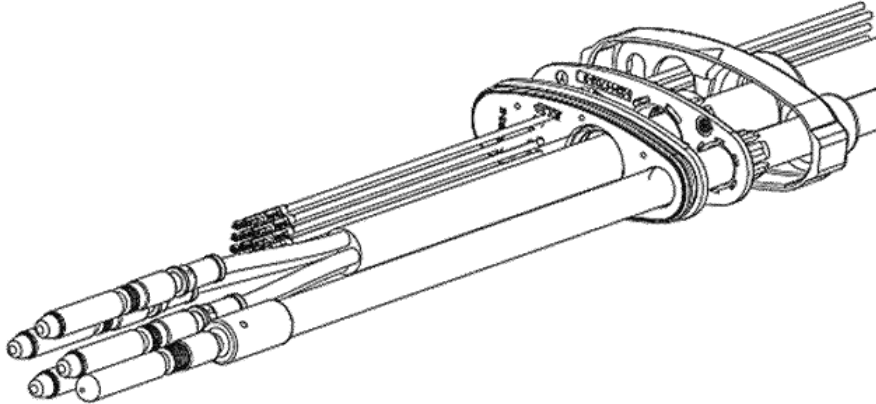

Figure 17 (schematic; crimp geometry not shown)

Step 5

Push signal terminals 794606-1 (Micro Mate'N'Lock) into the Connector Housing 1-794617-2 acc. application spec 114-13000. Pinning according to figure 18 and table 6:

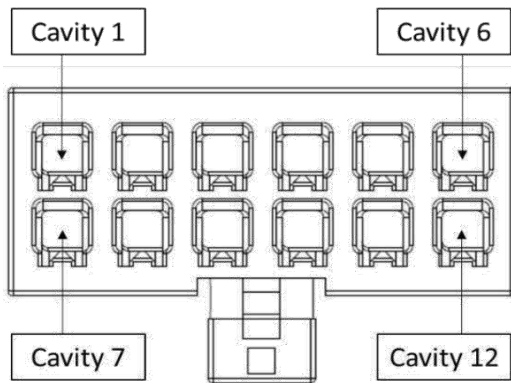

Figure 18

Cavity No.	Function
6	T DC+
7	Proxi
8	T GND
9	T DC-
10	T AC
11	PE S
12	CP

Table 7

After Micro Mate'N'Lock connector housing assembly the subassembly of cables with cable exit components is complete, see figure 19

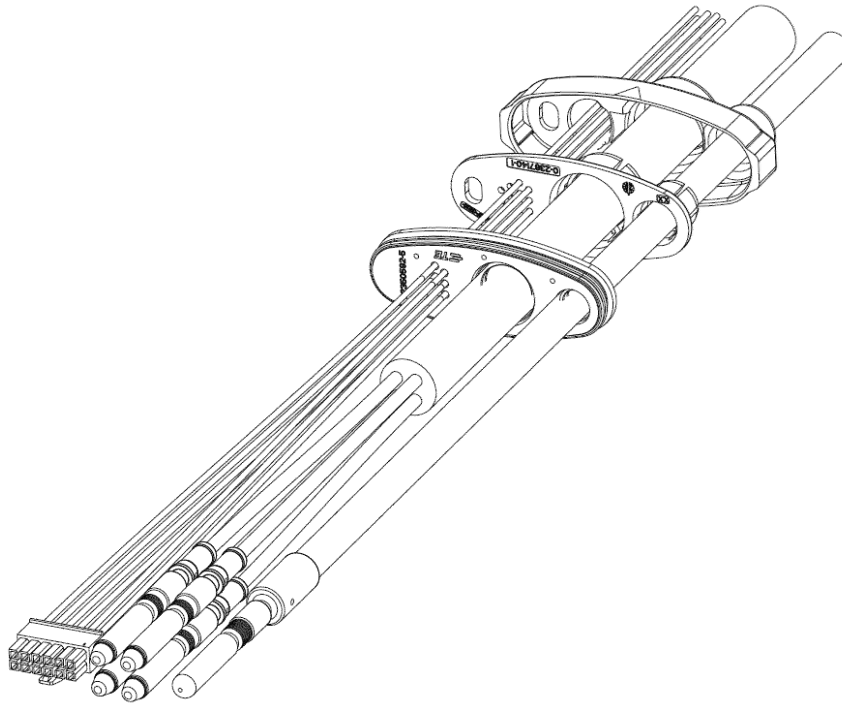

Figure 19 (schematic; crimp geometry not shown)

Step 6

The COVER CABLE SEAL DC 2366667-1 and FAMILY SEAL DC 2366539-1 must be pushed over the 70mm² DC-Power wires, figure 20. Especially ensure the correct position of the flange of the L-shaped FAMILY SEAL AC towards the COVER CABLE SEAL, figure 20a

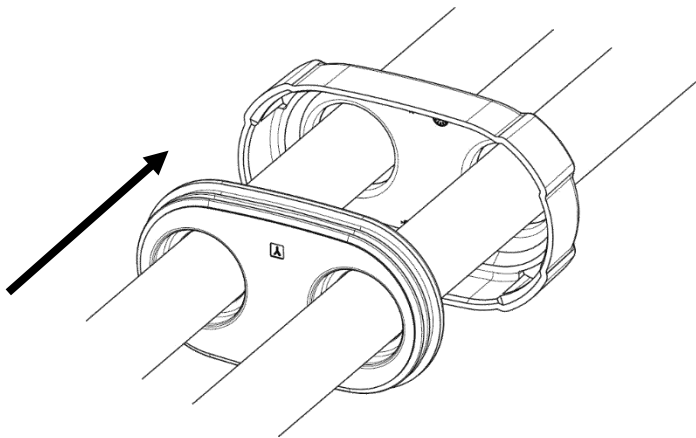

Figure 20

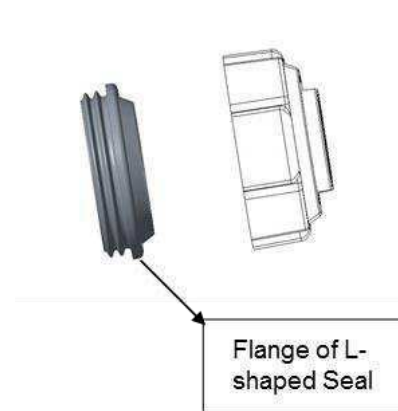

Figure 20a

Pass the cables through the DC area in the Cable Exit Combo Left 1-2303200-1 (figure 21) or Cable Exit Combo Right 1-2303200-2 (figure 21a)

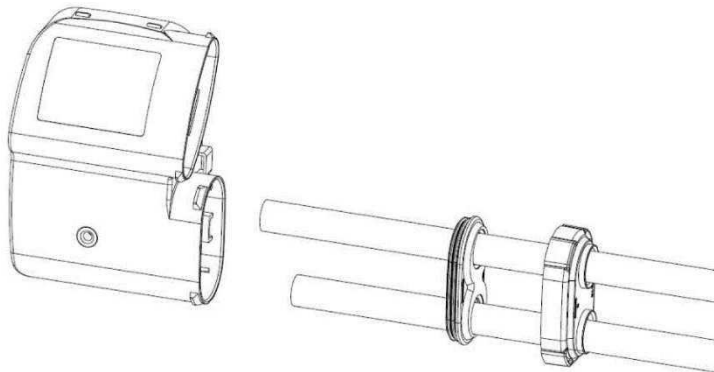

Figure 21

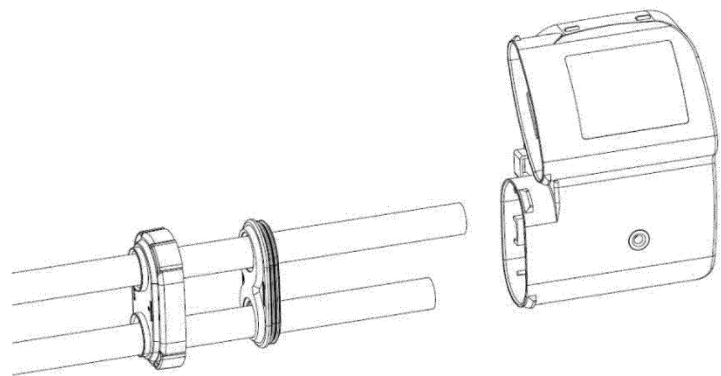
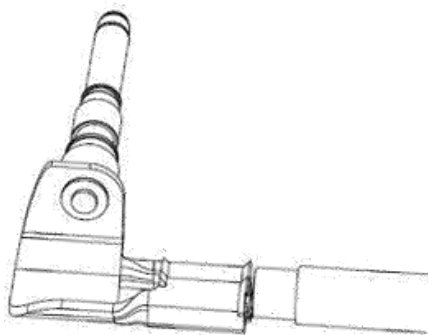

Figure 21a

Step 7

Dismantle the wires and crimp the contacts: **70 mm² DC Power Cables.**

Dismantle single wires and crimp the contacts 2306177-1 according to spec. 114-94436 Remove inner isolation acc. dimension B (figure 22, 22a and 23 and table 7).



Cable direction right

Figure 22

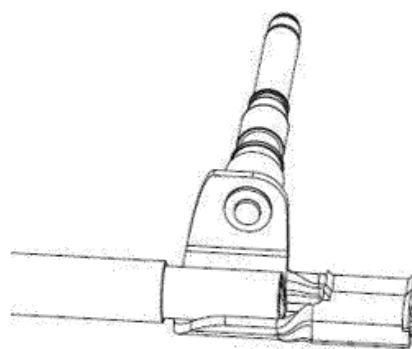

Cable direction left

Figure 22a

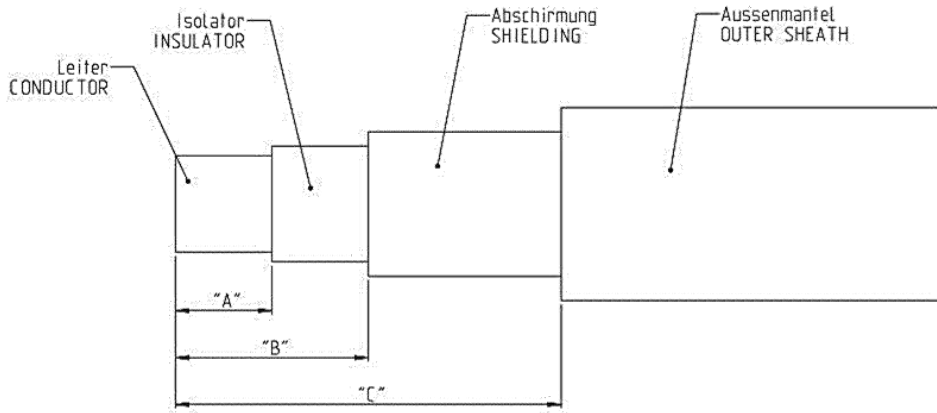

Figure 23

Dim	Cable direction RIGHT	Cable direction LEFT
Dim „A“	19 mm +/- 1mm	28 +/-1 mm
Dim „B“	29 mm +/- 1mm	63 +/-1 mm
Dim „C“	29 mm +/- 1mm	63 +/-1 mm

Table 8

For Charge Inlets with cable exit to the right (see figure 24), to the left (see figure 24a) the crimps need to be arranged as shown: DC- on the top cable position, DC+ on the lower.

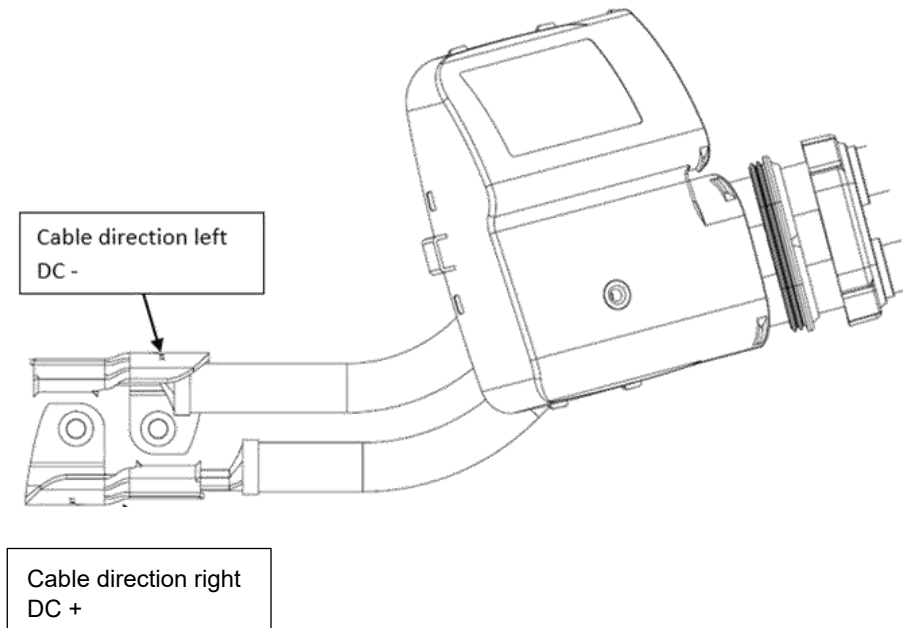

Figure 24

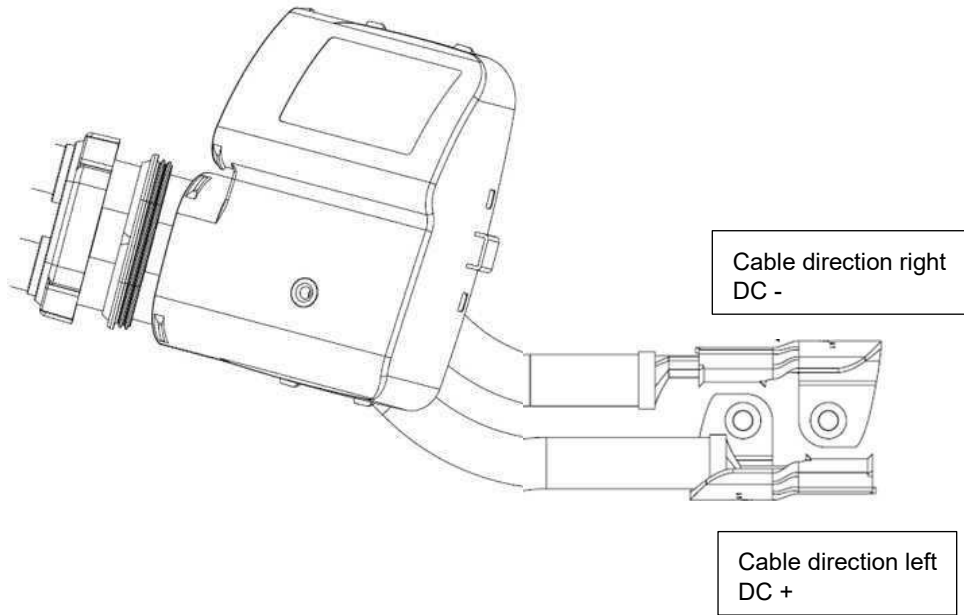

Figure 24a

Step 8

Assemble the DC contact seals 2120571-1 on the DC contact assemblies. (Figure 25). Pay attention to not damage the seal during handling. Make sure the seal does not twist or flip around, correct assembly is shown in figure 25a

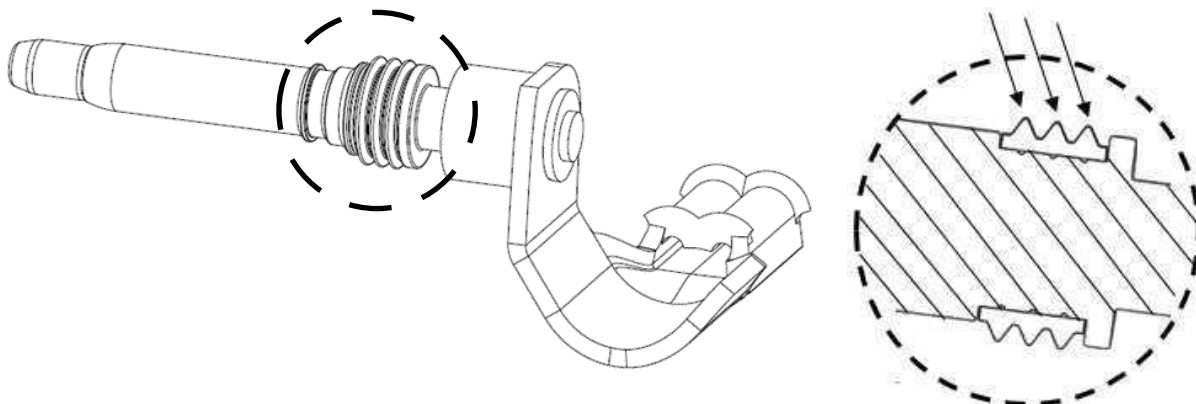

Figure 25

Figure 25a

Step 9

Pass the AC cable subassembly (figure 19) through the AC slot in Cable Exit 1-2303200-1 (figure 26). Pay attention on the symbol triangle and rectangle at the AC Seal Cover (figure 26 and 26a). Grounding cable is always in lower position at the cable exit.

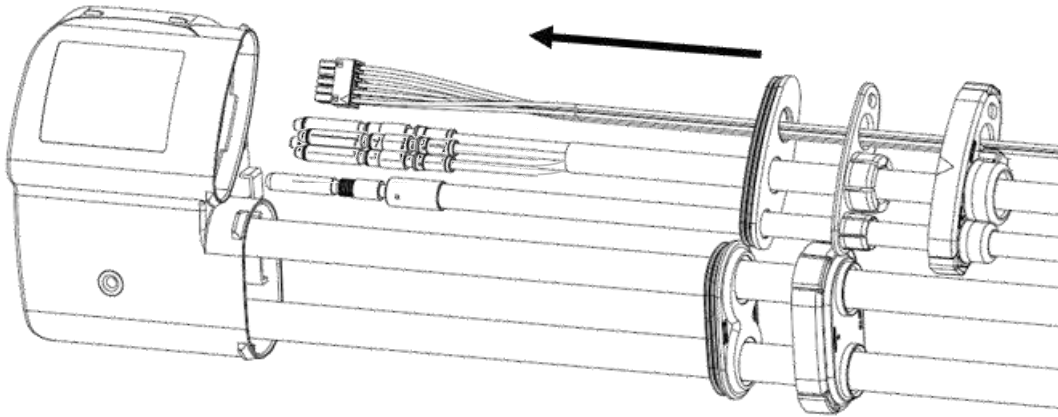

Figure 26 (exemplary)

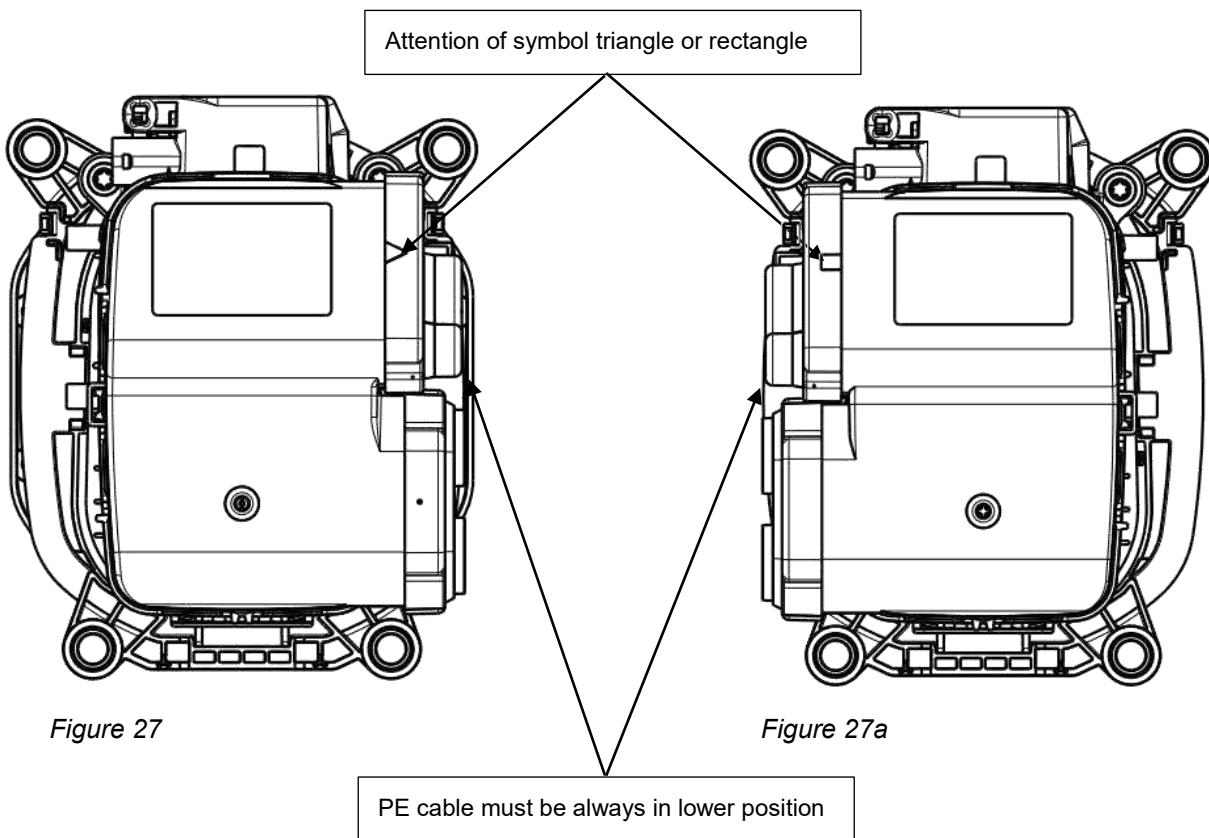

Figure 27

Figure 27a

Step 10

Insert the Contacts from the backside into the Inlet Housing according the cavity description (see figure 28) into their locking position, see figure 29. To ensure that the contacts are correctly inserted, pull with a low force on the cables (max. 10N). Figure 28a shows contacts assembled in end position.

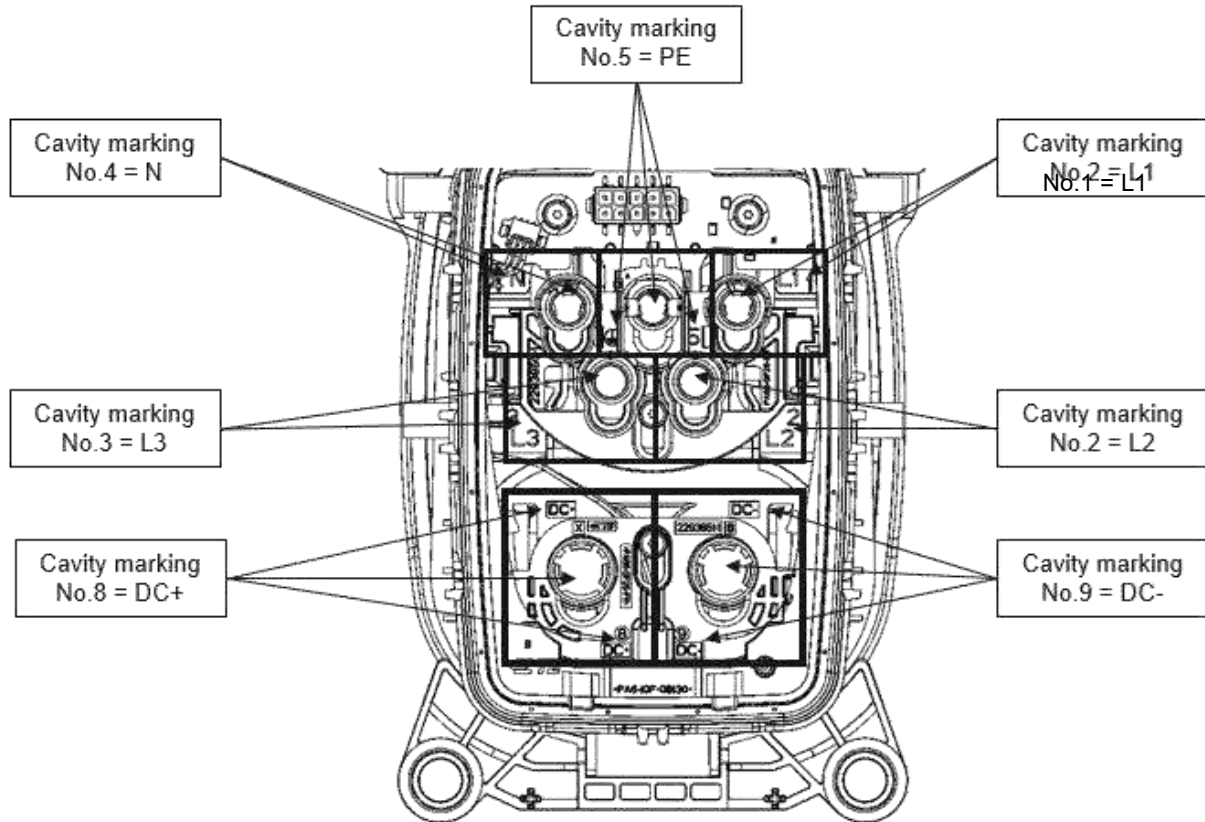

Figure 28

ATTENTION: The correct contact positions must be ensured BEFORE pushing the contacts into their cavities in locking position.

In case of wrong positioning of the contacts the complete assembly must be scrapped. There is no rework allowed (risk of damaging contacts and/or locking geometry in housing)!

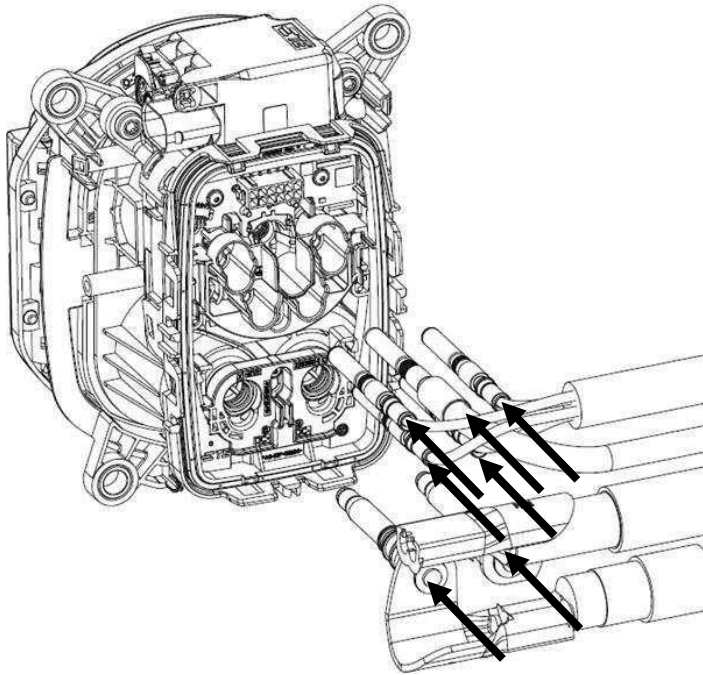

Figure 29

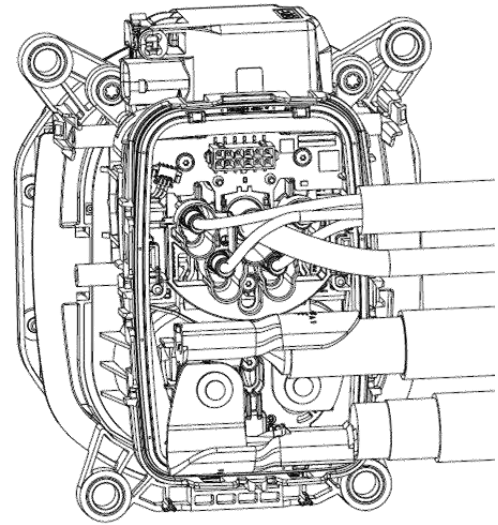

Figure 29a

Proposed sequence for contact insertion:

- 1.) 4x 6mm² AC Power Cable with contacts into L1, L2, L3 and N cavities
- 2.) 25 mm² Ground Cable with contact into PE/ground cavity
- 3.) 2x 70mm² DC Power Cable with contacts into DC+ and DC- cavities

Step 11

After the contacts have been controlled for correct positioning and locking, both SECONDARY LOCKS must be pushed upwards (Figure 30). Ensure that both latches are properly engaged with the inlet housing, which must be controlled by the double audible click and by visible inspection. Secondary Locks in end position shown in figure 31 and 31a:

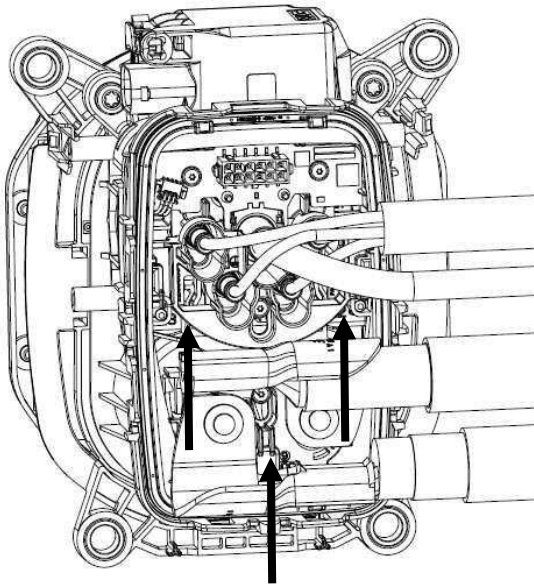
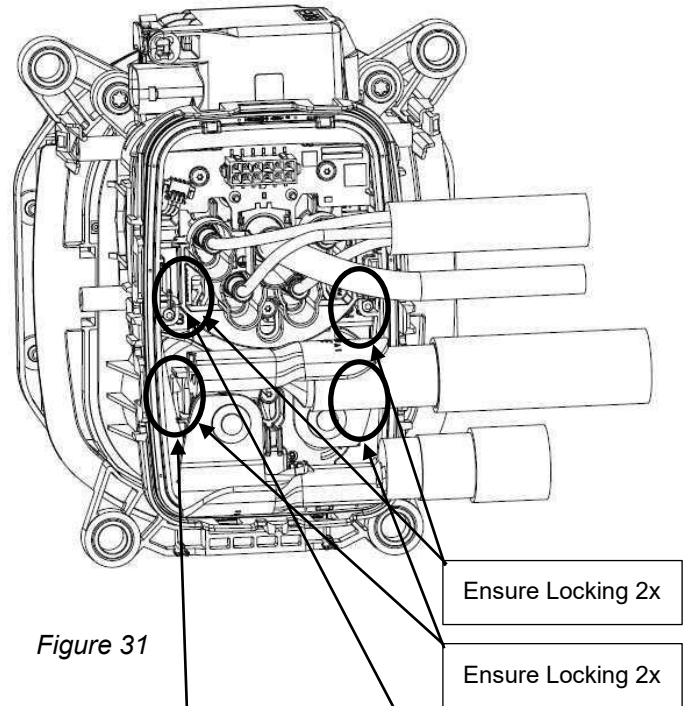
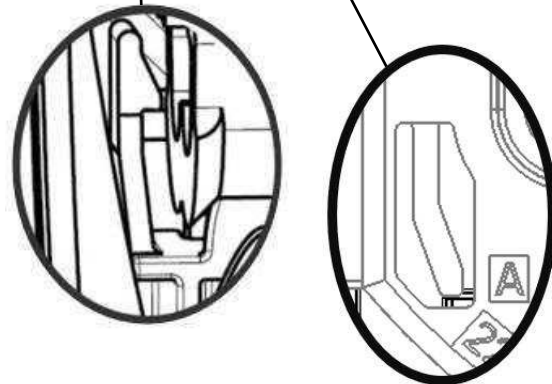
*Figure 30**Figure 31**Figure 31a*

Step 12

After the contacts have been locked with the SECONDARY LOCKS in both AC and DC area, the ADAPTER with preassembled Peripheral Seals (1 seal rust red, 1 seal green) has to be pushed in lock position (Figure 32). The press force has to be applied on the marked locations on the surrounding collar to close the latches. Ensure that all 7 hooks are correctly engaged. (Figure 33).

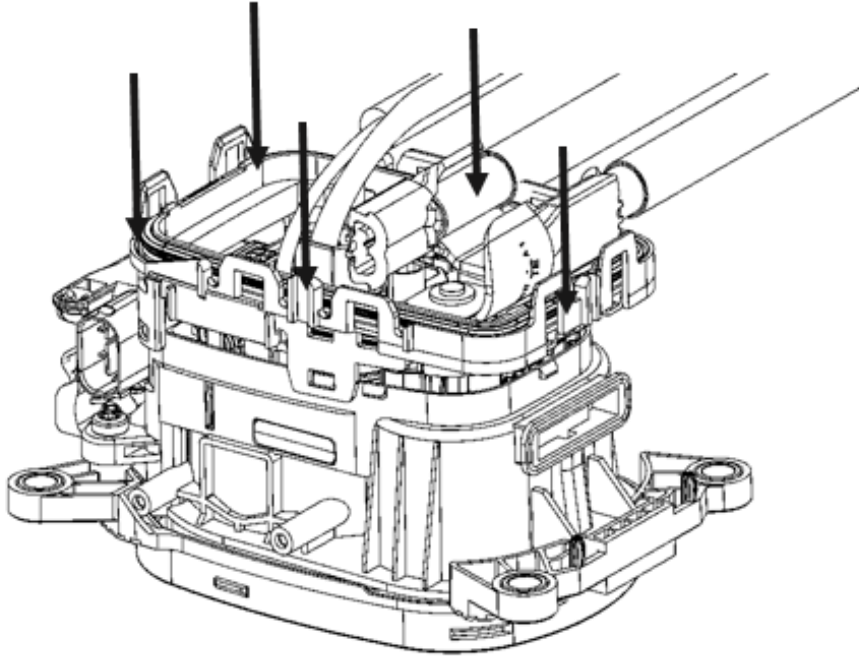

Figure 32 (Schematic view)

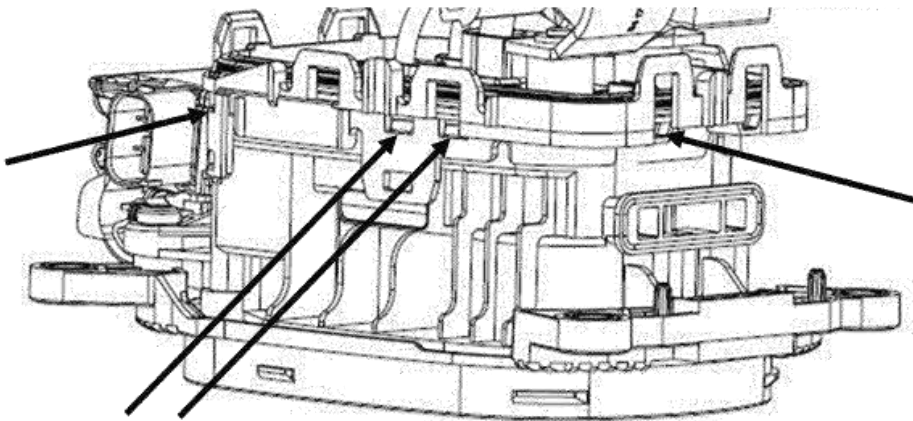

Figure 33

Step 13

Connect Micro Mate'N'Lock Connector to PCB-Header. Ensure the hook is properly engaged with the header, see figure 34.

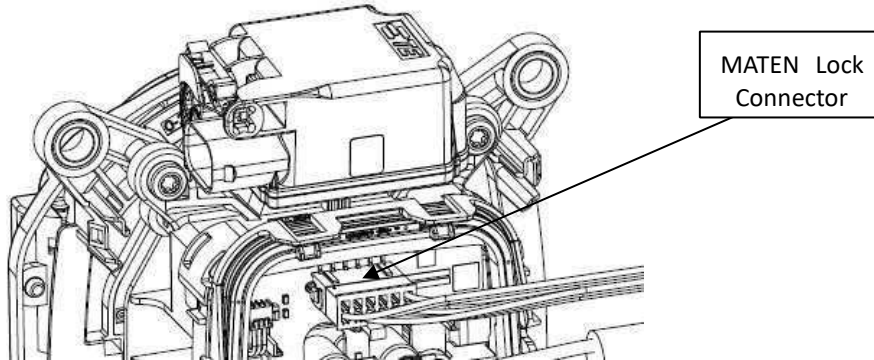

Figure 34

Step 14

Assemble the Cable Exit Cover Left 1-2303200-1 or Exit Cover Right 1-2303200-2 to the Inlet. Ensure that all 8 hooks are correctly engaged. (Figure 35). The press force must be applied on the marked locations close to the latches, see figure 35a.

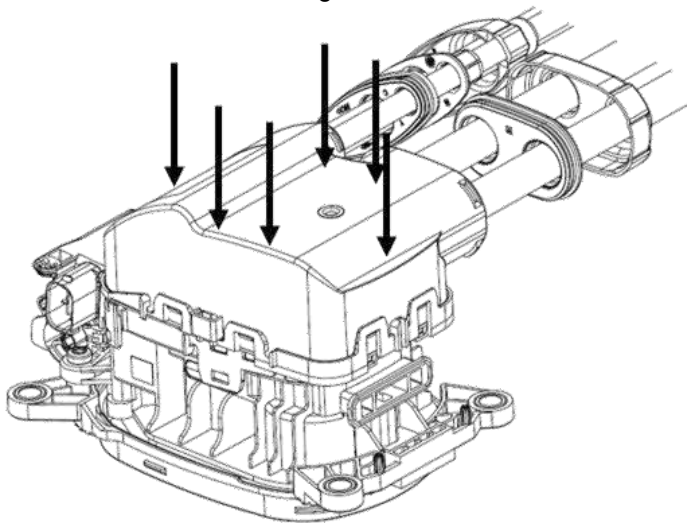

Figure 35

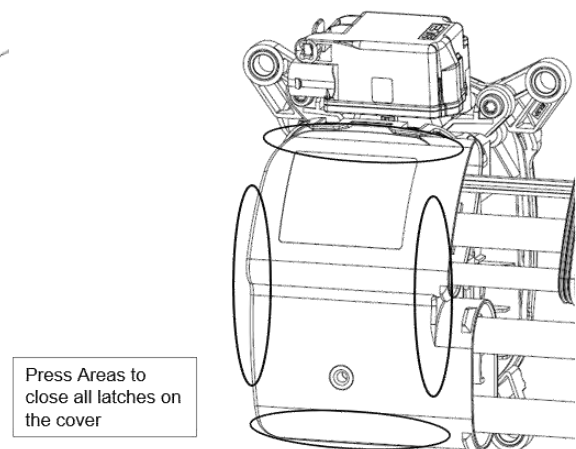

Figure 35a

ATTENTION: The Cable Exit Cover 1-2303200-1 and 1-2303200-2 needs to be aligned properly over the inlet and pushed vertically into position to make sure the seal slips correctly into the seating all around (figure 36)

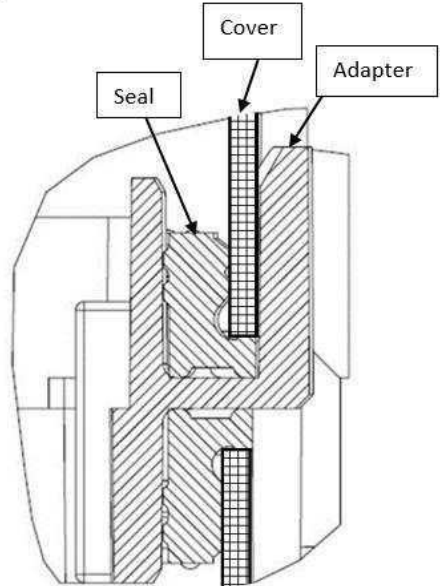

Figure 36

Step 15

Move the STRAIN RELIEF AC 2367140-1 together with FAMILY SEAL AC 1-2350592-5 into their position in the CABLE EXIT LEFT 1-2303200-1 OR RIGHT 1-2303200-2, see figure 37.



ATTENTION: Ensure that the AC-Multicore cable is well positioned in the FAMILY SEAL, that all seal lips are safely placed on the outer isolation of the cables. (Figure 38)

Push the COVER CABLE SEAL AC 2296057-2 over it and snap it on the CABLE EXIT COVER LEFT 1-2303200-1 OR RIGHT 1-2303200-2. Ensure that both hooks are correctly engaged (double audible click), see figure 38.

Move the FAMILY SEAL DC 2366539-1 into position in the CABLE EXIT CABLE EXIT LEFT 1-2303200-1 OR RIGHT 1-2303200-2, see figure 38a.

Push the COVER CABLE SEAL 2366667-1 over it and snap it on the CABLE EXIT COVER LEFT 1-2303200-1 OR RIGHT 1-2303200-2. Ensure that all four hooks are correctly engaged (Quadro audible click), see figure 38a.

ATTENTION: Ensure that the DC power cables are well positioned in the FAMILY SEAL, that all seal lips are safely placed on the outer isolation of the cables. (Figure 38a)

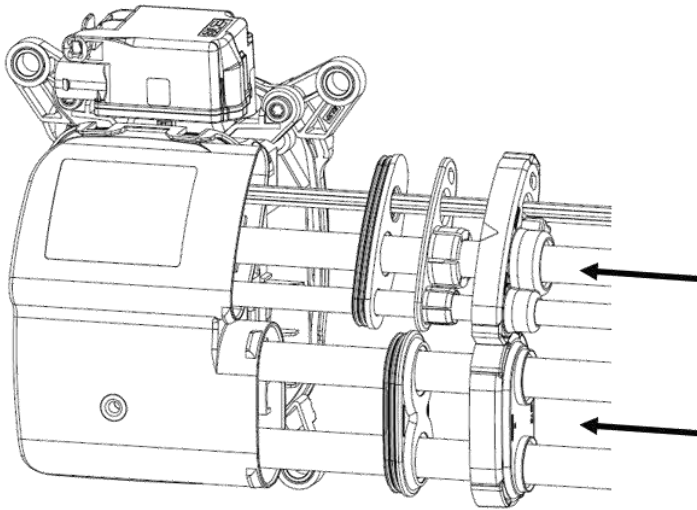

Figure 37

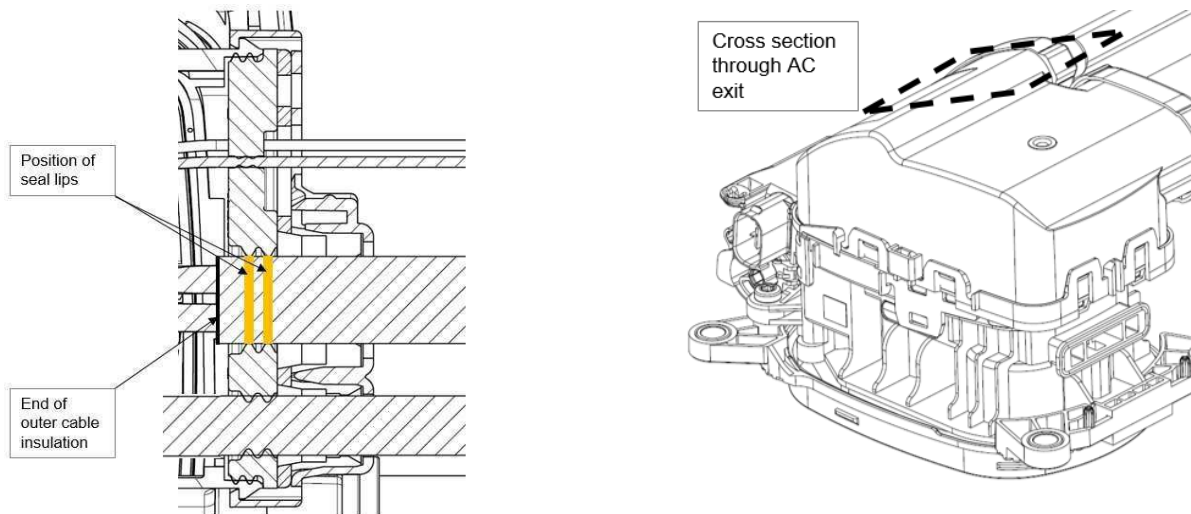

Figure 38 – AC seal lips

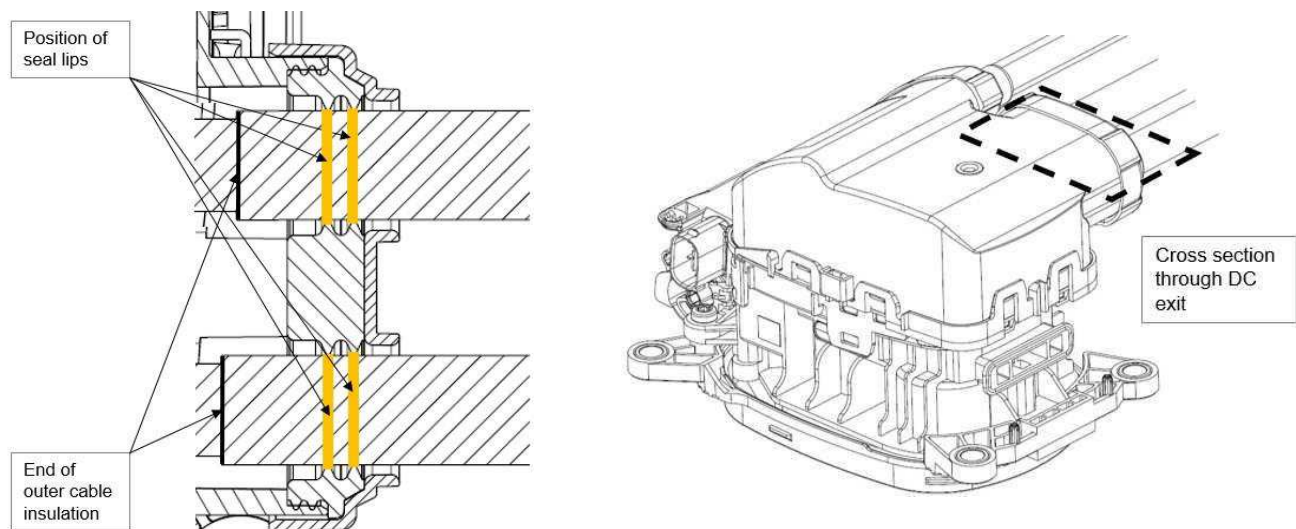

Figure 38a – DC seal lips

Step 16

Assemble Protection Cap 2292534-1 at Inlet Housing, see figure 39.

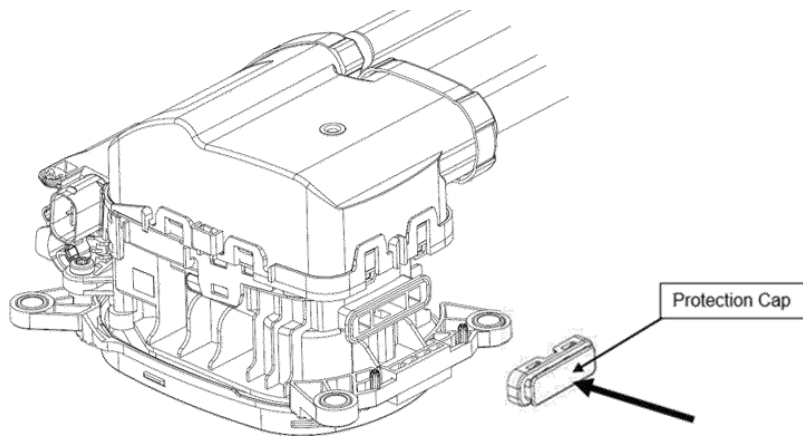

Figure 39

Step 17

As part of the End of Line Test as listed in Chapter 7.7), perform the tightness check of the fully assembled charge inlet. The pressure port on the rear of CABLE EXIT COVER 1-2303200-1 (shown in figure 40) or 1-2303200-2 is designed to fit an elastic plastic tube (Polyurethane or similar) with an outer diameter of 4mm.

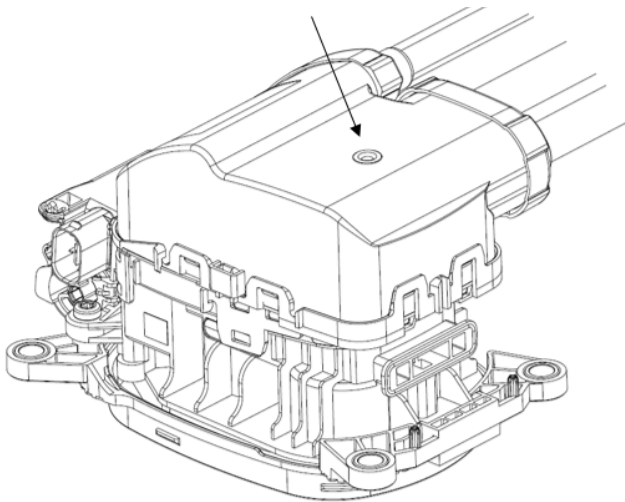

Figure 40

The tubular geometry of the pressure port has a reduced inner diameter towards the bottom to increase the pressure on the elastic tube when being inserted. The tube needs to be pushed that far into the pressure port that a reliable sufficient air tightness can be achieved, see figure 41 for exemplarily inserted tube.

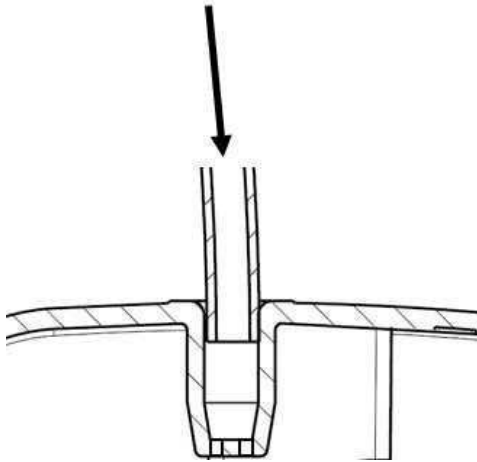

Figure 41

For the tightness check it is intended to perform an air differential pressure decay leak measurement test. Pressure profile is 0,1...0,15 bar, preferably under pressure. Acceptance criterion is pressure loss over time and has to be defined based on particularly prepared failure test samples

After successfully passed tightness check the pressure port needs to be closed with the MQS CAVITY PLUG 963143-1

The MQS CAVITY PLUG needs to be FULLY inserted into the pressure port, see figure 42. The bottom of the pressure port is closed with a cross geometry to avoid that the MQS Cavity Plug could be pushed through.

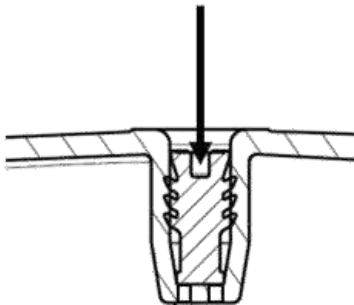



Figure 42

Step 18

For identification apply the label on this specified polished face on the CABLE EXIT, see figure 43. The label needs to include information acc. requirements of IEC 62196-x and IEC 61851. Additional information acc. to customer requirements can be applied here.

Marking acc. IEC62196-3:

Manufacturers name or trademark	XXXXX
Type reference or identification number	Art.: XXXXXXX
Rated currents, maximum voltages and frequency	Max. 32A, 480V~50-60Hz / Max.200A, 1.000V
Number of Phases	3L / N / \oplus / DC+ / DC- 
Degree of protection	IP67

There may apply additional national marking requirements, depending on the market/country the vehicle will be configured for. Also, information acc. to customer requirements can be applied here. As a compatible label TE p/n 5-1768421-9 is recommended.

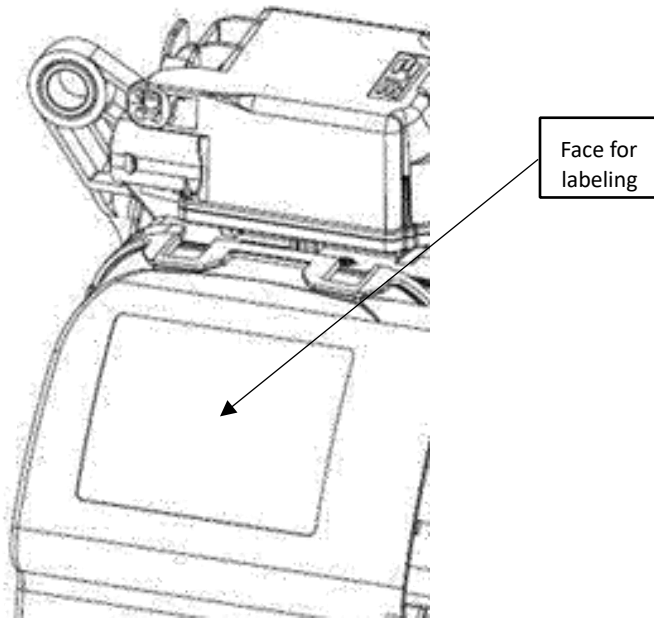

Figure 43

7.7 End of Line Test



The assembled Charge Inlet has to be tested electrically and mechanically to applicable requirements, including High Voltage test.

As a minimum, following tests have to be performed:

- Isolation Resistance: Test Voltage: 500VDC Inspection Duration: 1s min. Riso: 200MOhm pin-to-pin, excluding CP-to-Proxi and CP/Proxi-to-Ground a) L1, L2, L3 and N versus PE
- b) L1 versus L2
- c) L2 versus L3
- d) L3 versus N
- e) L1, L2, L3 and N versus AC multicore shield
- f) DC+ versus DC-

- Dielectric withstand voltage: Test Voltage: 2000VAC Inspection Duration: 1s max. Leakage current: 10mA pin-to-pin, excluding CP-to-Proxi and CP/Proxi-to-Ground a) L1, L2, L3 and N versus PE
- b) L1 versus L2
- c) L1 versus L3
- d) L1 versus N
- e) L2 versus L3
- f) L2 versus N
- g) L3 versus N
- h) L1, L2, L3 and N versus AC multicore shield
- i) DC+ versus DC-
- j) DC+ and DC- versus HV cable shield

- Correct Pinning of all Contacts

- Check seals for correct seating by Tightness Check of completed Charge Inlet Harness Assy (Air pressure test)

- Check correct assembled MQS Cavity Plug in the pressure port after Tightness Check.

- Functionality check of actuator. Drive (first) in lock and (second) in unlock position. During this operation, the actuator pull ring / pull cable becomes pulled back in end position.

- Conduct a functional check on the temperature sensor and verify the resistance values as specified in the table under 'Testing Parameters PCB' in the customer drawing of the inlet housing assembly.

LTR	REVISION RECORD	DWN	APVP	DATE
1	INITIAL DOCUMENT	B. KOSCH	J. KOESTER	05.05.2021
2	REV A1: TYPING ERROR: CHANGE AC-SEAL FROM 2350592-5 TO 1-2350592-5	B. KOSCH	J. KOESTER	19.07.2021
3	REV B: CHAPTER 2 AND CHAPTER 3: PE CABLE, 25MM ² SUPPLIER DETAILS CHANGED FROM RAYCHEM TO H&S	SRAVANI N S	KASHYAP P B	12.04.2023
4	REV B1: 24V ACTUATOR VARIANTS ADDED	AJITH JAMES	KASHYAP P B	12.02.2024
5	REV. B2: BOM QTY FOR Pos – 4 UPDATED FOR 12V & 24V CHAPTER 7.7: END OF LINE TEST ADDED	KRUTHI G	KASHYAP P B	19.11.2024

DRW B. KOSCH	TE CONNECTIVITY GERMANY GMBH AMPÈRESTRASSE 12-14 D-64625 BENSHEIM GERMANY		
CHK U. SIEGEL			
APVP J. KOESTER	NO 114-94675	REV B	LOC AI
TITLE	<p style="text-align: center;">Application Specification Vehicle Charge Inlet Type COMBO 2 acc. IEC62196-3</p>		