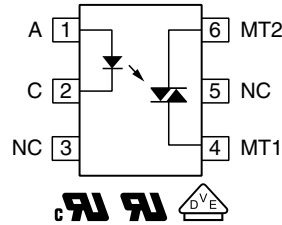
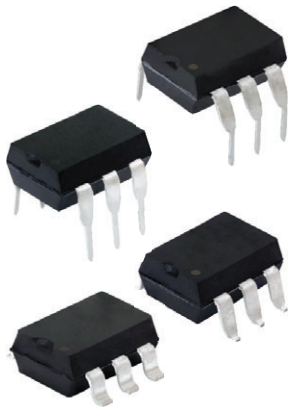


Optocoupler, Phototriac Output, Non-Zero Crossing



FEATURES

- $I_{RMS} = 300 \text{ mA}$
- High static $dV/dt < 10\,000 \text{ V}/\mu\text{s}$
- Electrically insulated between input and output circuit
- Microcomputer compatible - very low trigger current
- Trigger current
 - ($I_{FT} < 1.2 \text{ mA}$) BRT12F
 - ($I_{FT} < 2 \text{ mA}$) BRT12H, BRT13H
 - ($I_{FT} < 3 \text{ mA}$) BRT13M
- Non-zero voltage detectors high input sensitivity
- Material categorization: for definitions of compliance please see www.vishay.com/doc?99912


RoHS
COMPLIANT

LINKS TO ADDITIONAL RESOURCES



DESCRIPTION

The BRT12 and BRT13 product family consists of AC optocouplers non-zero voltage detectors consisting of two electrically insulated lateral power ICs which integrate a thyristor system, a photo detector and noise suppression at the output and an IR GaAs diode input.

APPLICATIONS

- Industrial controls
- Office equipment
- Consumer appliances

AGENCY APPROVALS

- [UL 1577](#)
- [cUL](#)
- [DIN EN 60747-5-5 \(VDE 0884-5\)](#), available with option 1

| ORDERING INFORMATION | | | | |
|--|---------------------------|---|-----------------------------|--|
| <div style="display: flex; justify-content: space-around; align-items: center;"> <div style="border: 1px solid black; padding: 2px;">B</div> <div style="border: 1px solid black; padding: 2px;">R</div> <div style="border: 1px solid black; padding: 2px;">T</div> <div style="border: 1px solid black; padding: 2px;">1</div> <div style="border: 1px solid black; padding: 2px;">#</div> <div style="border: 1px solid black; padding: 2px;">x</div> </div> <p style="text-align: center;">PART NUMBER</p> | | <div style="display: flex; justify-content: space-around; align-items: center;"> <div style="border: 1px solid black; padding: 2px;">-</div> <div style="border: 1px solid black; padding: 2px;">X</div> <div style="border: 1px solid black; padding: 2px;">0</div> <div style="border: 1px solid black; padding: 2px;">#</div> <div style="border: 1px solid black; padding: 2px;">#</div> </div> <p style="text-align: center;">PACKAGE OPTION</p> | | <div style="border: 1px solid black; padding: 2px; text-align: center;">T</div> <p style="text-align: center;">TAPE AND REEL</p> |
| AGENCY CERTIFIED / PACKAGE | $V_{DRM} \text{ (V)}$ | | | |
| | ≤ 600 | | ≤ 800 | |
| UL | $I_{FT} = 1.2 \text{ mA}$ | $I_{FT} = 2 \text{ mA}$ | $I_{FT} = 2 \text{ mA}$ | |
| DIP-6 | BRT12F | BRT12H | BRT13H | |
| DIP-6, 400 mil, option 6 | - | BRT12H-X006 | BRT13H-X006 | |
| SMD-6, option 7 | BRT12F-X007T | BRT12H-X007T | BRT13H-X007T ⁽¹⁾ | |
| SMD-6, option 9 | - | BRT12H-X009T | BRT13H-X009T | |
| UL, VDE | $I_{FT} = 1.2 \text{ mA}$ | $I_{FT} = 2 \text{ mA}$ | $I_{FT} = 2 \text{ mA}$ | |
| DIP-6 | - | BRT12H-X001 | - | |
| DIP-6, 400 mil, option 6 | - | BRT12H-X016 | - | |
| SMD-6, option 7 | - | - | BRT13H-X017T | |

Note

⁽¹⁾ Also available in tube, do not put T on the end



| ABSOLUTE MAXIMUM RATINGS ($T_{amb} = 25\text{ }^{\circ}\text{C}$, unless otherwise specified) | | | | | |
|--|--------------------------------|-------|------------|-------------|--------------------|
| PARAMETER | TEST CONDITION | PART | SYMBOL | VALUE | UNIT |
| INPUT | | | | | |
| Reverse voltage | | | V_R | 6 | V |
| Forward current | | | I_F | 20 | mA |
| Surge forward current | | | I_{FSM} | 1.5 | A |
| Power dissipation | $t \leq 10\text{ }\mu\text{s}$ | | P_{diss} | 30 | mW |
| OUTPUT | | | | | |
| Repetitive peak off-state voltage | | BRT12 | V_{DRM} | 600 | V |
| | | BRT13 | V_{DRM} | 800 | V |
| RMS on-state current | | | I_{TRMS} | 300 | mA |
| Single cycle surge current | 50 Hz | | I_{TSM} | 3 | A |
| Power dissipation | | | P_{diss} | 600 | mW |
| COUPLER | | | | | |
| Maximum power dissipation | | | P_{tot} | 630 | mW |
| Reference voltage in accordance with VDE 0110 b | | | V_{ref} | 500 | V_{RMS} |
| Reference voltage in accordance with VDE 0110 b (insulation group C) | | | V_{ref} | 600 | V_{DC} |
| Storage temperature range | | | T_{stg} | -40 to +150 | $^{\circ}\text{C}$ |
| Ambient temperature range | | | T_{amb} | -40 to +100 | $^{\circ}\text{C}$ |

Notes

- Stresses in excess of the absolute maximum ratings can cause permanent damage to the device. Functional operation of the device is not implied at these or any other conditions in excess of those given in the operational sections of this document. Exposure to absolute maximum ratings for extended periods of the time can adversely affect reliability.
- (1) Test AC voltage in accordance with DIN 57883, June 1980

| ELECTRICAL CHARACTERISTICS ($T_{amb} = 25\text{ }^{\circ}\text{C}$, unless otherwise specified) | | | | | | | |
|--|--|-------|---------------|------|------|------|-------------------------|
| PARAMETER | TEST CONDITION | PART | SYMBOL | MIN. | TYP. | MAX. | UNIT |
| INPUT | | | | | | | |
| Forward voltage | $I_F = 10\text{ mA}$ | | V_F | - | 1.1 | 1.35 | V |
| Reverse current | $V_R = 6\text{ V}$ | | I_R | - | - | 10 | μA |
| Thermal resistance, junction to ambient (1) | | | R_{thJA} | - | - | 750 | $^{\circ}\text{C/W}$ |
| OUTPUT | | | | | | | |
| Peak off-state voltage | $I_{D(RMS)} = 100\text{ }\mu\text{A}$ | BRT12 | V_{DM} | - | 600 | - | μA |
| | | BRT13 | | - | 800 | - | μA |
| Off-state current | $T_C = 80\text{ }^{\circ}\text{C}, V_{DRM}$ | | I_D | - | 0.5 | 100 | μA |
| On-state voltage | $I_T = 300\text{ mA}$ | | V_T | - | - | 2.3 | V |
| Pulse current | $t_p \leq 5\text{ }\mu\text{s}, f = 100\text{ Hz}, dl_{tp}/dt \leq 8\text{ A}/\mu\text{s}$ | | I_{tp} | - | - | 2 | A |
| Critical rate of rise of off-state voltage | $V_D = 0.67 V_{DRM}, T_j = 25\text{ }^{\circ}\text{C}$ | | dV/dt_{cr} | 10 | - | - | $\text{kV}/\mu\text{s}$ |
| | $V_D = 0.67 V_{DRM}, T_j = 80\text{ }^{\circ}\text{C}$ | | dV/dt_{cr} | 5 | - | - | $\text{kV}/\mu\text{s}$ |
| Critical rate of rise of voltage at current commutation | $V_D = 0.67 V_{DRM}, T_j = 25\text{ }^{\circ}\text{C}, dl/dt_{crq} \leq 15\text{ A/ms}$ | | dV/dt_{crq} | 10 | - | - | $\text{kV}/\mu\text{s}$ |
| | $V_D = 0.67 V_{DRM}, T_j = 80\text{ }^{\circ}\text{C}, dl/dt_{crq} \leq 15\text{ A/ms}$ | | dV/dt_{crq} | 5 | - | - | $\text{kV}/\mu\text{s}$ |
| Critical rate of rise of on-state at current | | | dl/dt_{cr} | 8 | - | - | $\text{A}/\mu\text{s}$ |
| Holding current | $V_D = 10\text{ V}$ | | I_H | - | 80 | 500 | μA |
| Thermal resistance, junction to ambient | | | R_{thJA} | - | - | 125 | $^{\circ}\text{C/W}$ |

| ELECTRICAL CHARACTERISTICS ($T_{amb} = 25\text{ }^{\circ}\text{C}$, unless otherwise specified) | | | | | | | |
|--|---|------|----------------------------|------|------|------|--------------------------------|
| PARAMETER | TEST CONDITION | PART | SYMBOL | MIN. | TYP. | MAX. | UNIT |
| COUPLER | | | | | | | |
| Trigger current | $V_D = 10\text{ V}$, F - versions | | I_{FT} | - | - | 1.2 | mA |
| | $V_D = 10\text{ V}$, H - versions | | I_{FT} | 0.4 | - | 2 | mA |
| | $V_D = 10\text{ V}$, M - versions | | I_{FT} | 0.8 | - | 3 | mA |
| Trigger current temperature gradient | | | $\Delta I_{FT}/\Delta T_j$ | - | 7 | 14 | $\mu\text{A}/^{\circ}\text{C}$ |
| Capacitance (input to output) | $f = 1\text{ MHz}$, $V_R = 0\text{ V}$ | | C_{IO} | - | - | 2 | pF |

Notes

- Minimum and maximum values are testing requirements. Typical values are characteristics of the device and are the result of engineering evaluation. Typical values are for information only and are not part of the testing requirements.
- (1) Static air, SITAC soldered in PCB or base plate

| SAFETY AND INSULATION RATINGS | | | | |
|--|---|------------|----------------|--------------------|
| PARAMETER | TEST CONDITION | SYMBOL | VALUE | UNIT |
| Climatic classification | According to IEC 68 part 1 | | 55 / 100 / 21 | |
| Comparative tracking index | | CTI | 175 | |
| Maximum rated withstanding isolation voltage | $t = 1\text{ min}$ | V_{ISO} | 4420 | V_{RMS} |
| Maximum transient isolation voltage | | V_{IOTM} | 10 000 | V_{peak} |
| Maximum repetitive peak isolation voltage | | V_{IORM} | 890 | V_{peak} |
| Isolation resistance | $V_{IO} = 500\text{ V}$, $T_{amb} = 25\text{ }^{\circ}\text{C}$ | R_{IO} | $\geq 10^{12}$ | Ω |
| | $V_{IO} = 500\text{ V}$, $T_{amb} = 100\text{ }^{\circ}\text{C}$ | R_{IO} | $\geq 10^{11}$ | Ω |
| Output safety power | | P_{SO} | 400 | mW |
| Input safety current | | I_{SI} | 275 | mA |
| Safety temperature | | T_S | 175 | $^{\circ}\text{C}$ |
| Creepage distance | DIP-6; SMD-6, option 7; SMD-6, option 9 | | ≥ 7 | mm |
| Clearance distance | | | ≥ 7 | mm |
| Creepage distance | DIP-6, option 6 | | ≥ 8 | mm |
| Clearance distance | | | ≥ 8 | mm |
| Insulation thickness | | DTI | ≥ 0.4 | mm |

Note

- As per IEC 60747-5-5, § 7.4.3.8.2, this optocoupler is suitable for "safe electrical insulation" only within the safety ratings. Compliance with the safety ratings shall be ensured by means of protective circuits.

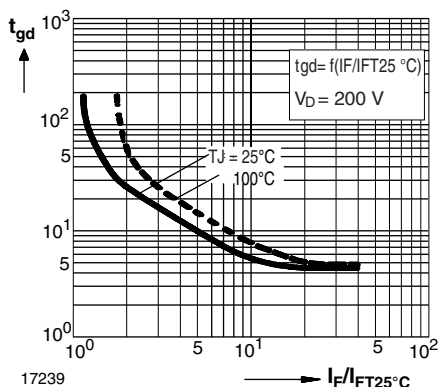
TYPICAL CHARACTERISTICS ($T_{amb} = 25\text{ }^{\circ}\text{C}$, unless otherwise specified)


Fig. 1 - Typical Trigger Delay Time

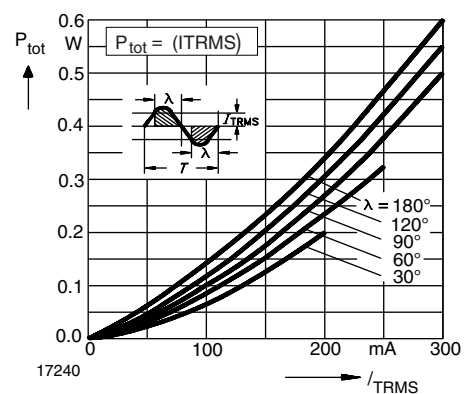


Fig. 2 - Power Dissipation 60 Hz to 60 Hz Line Operation

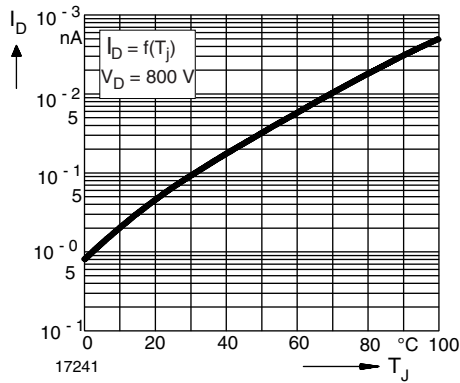


Fig. 3 - Typical Off-State Current

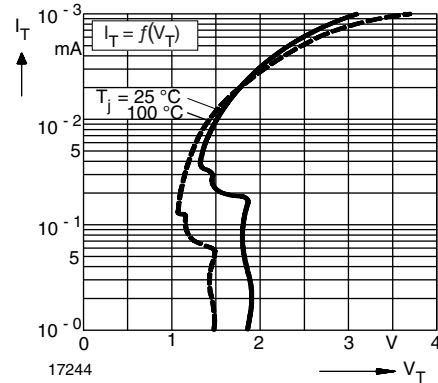


Fig. 6 - Typical Output Characteristics

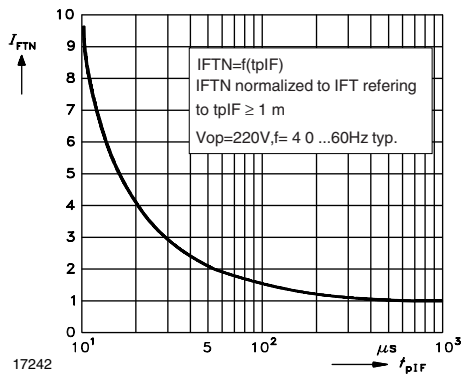


Fig. 4 - Pulse Trigger Current

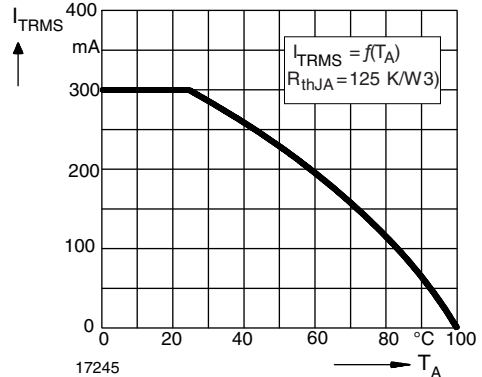


Fig. 7 - Current Reduction

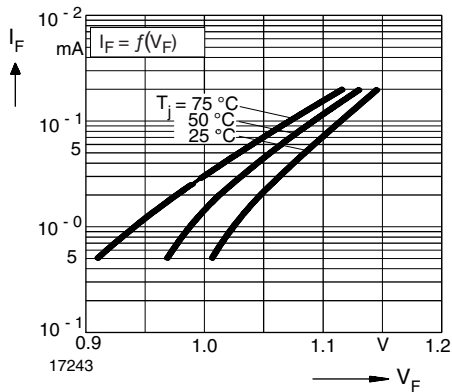


Fig. 5 - Typical Input Characteristics

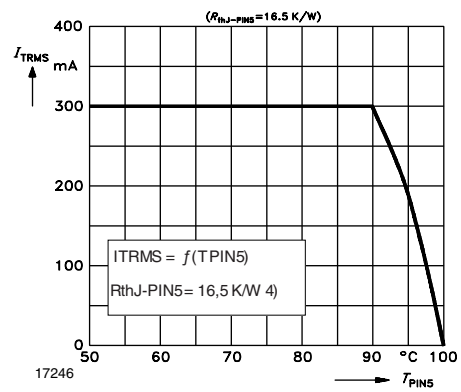
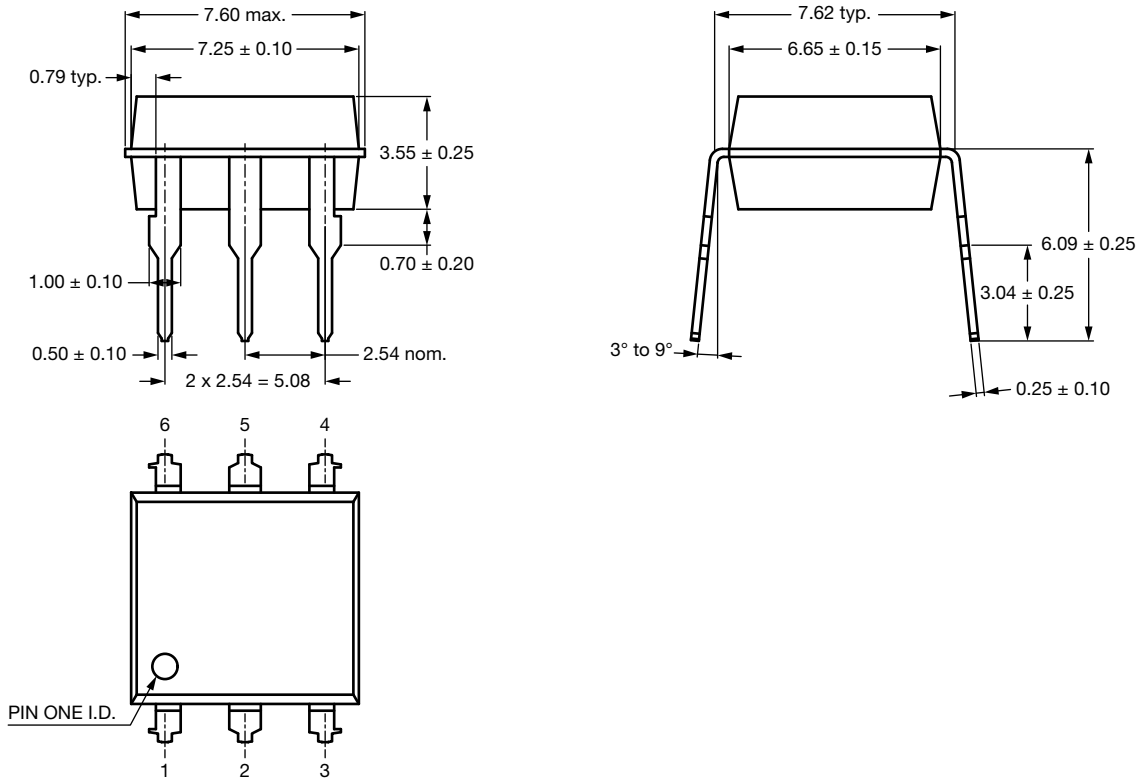


Fig. 8 - Current Reduction

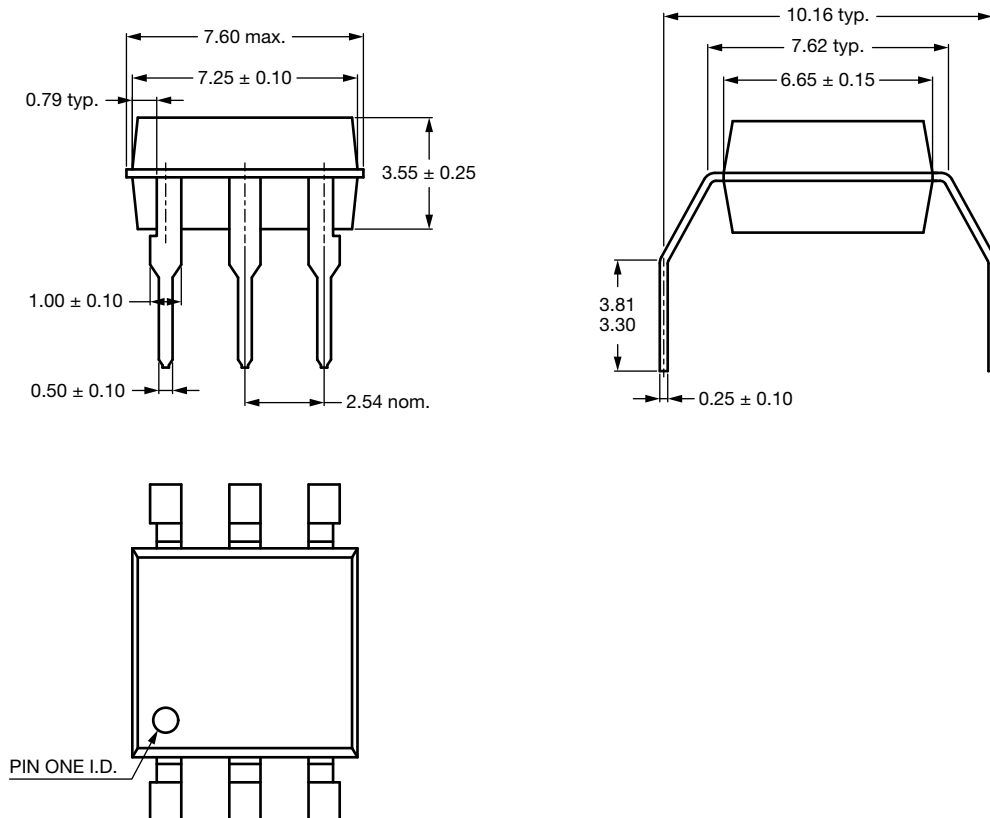


PACKAGE DIMENSIONS in millimeters

DIP-6

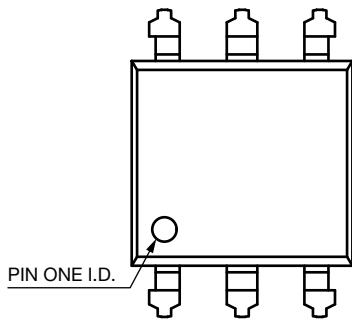
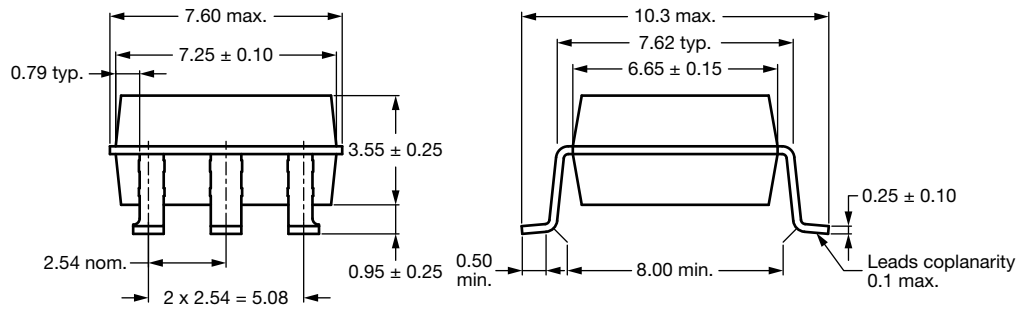


DIP-6, 400 mil (option 6)

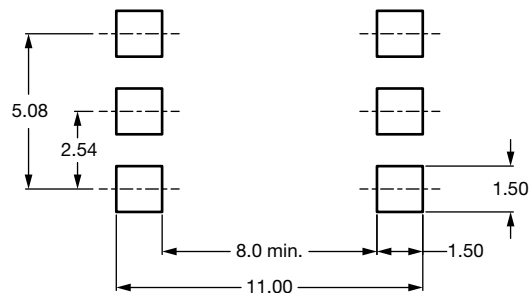




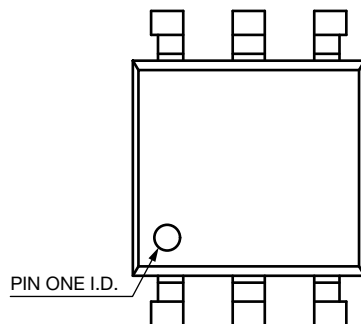
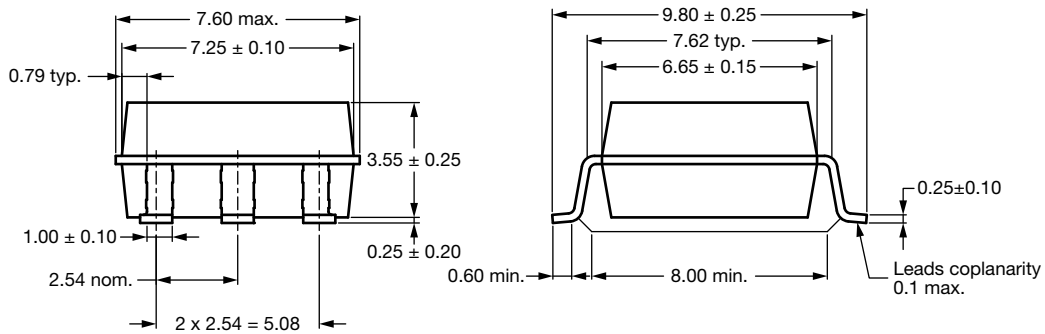
SMD-6 (option 7)



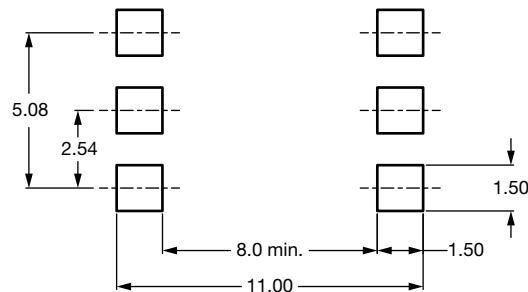
Recommended footprint



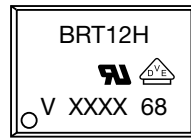
SMD-6 (option 9)



Recommended footprint



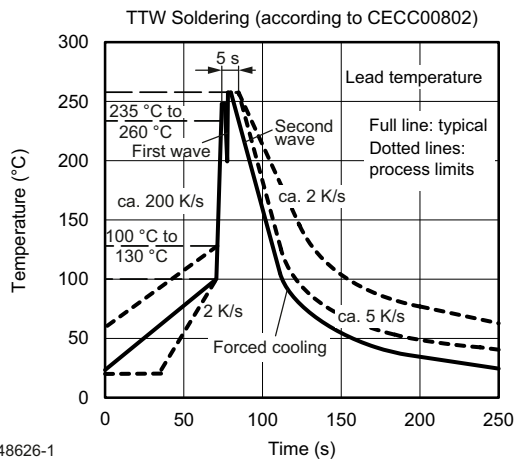
PACKAGE MARKING (example)



Notes

- XXXX = LMC (lot marking code)
- VDE logo is only marked on option 1 parts
- Tape and reel suffix (T) is not part of the package marking

SOLDER PROFILES



948626-1

Fig. 9 - Wave Soldering Double Wave Profile According to J-STD-020 for DIP Devices

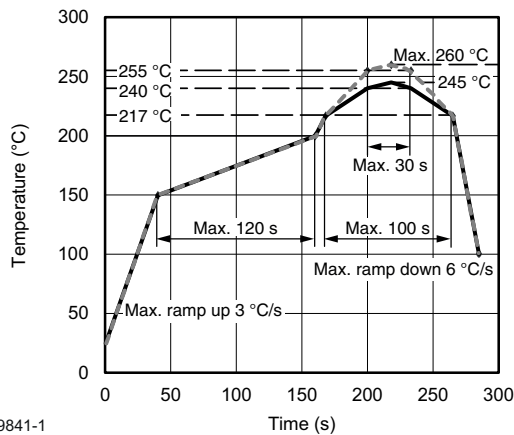
HANDLING AND STORAGE CONDITIONS

ESD level: HBM class 2

Floor life: unlimited

Conditions: $T_{amb} < 30\text{ }^{\circ}\text{C}$, RH < 85 %

Moisture sensitivity level 1, according to J-STD-020



19841-1

Fig. 10 - Lead (Pb)-free Reflow Solder Profile According to J-STD-020 for SMD Devices



Disclaimer

ALL PRODUCT, PRODUCT SPECIFICATIONS AND DATA ARE SUBJECT TO CHANGE WITHOUT NOTICE TO IMPROVE RELIABILITY, FUNCTION OR DESIGN OR OTHERWISE.

Vishay Intertechnology, Inc., its affiliates, agents, and employees, and all persons acting on its or their behalf (collectively, "Vishay"), disclaim any and all liability for any errors, inaccuracies or incompleteness contained in any datasheet or in any other disclosure relating to any product.

Vishay makes no warranty, representation or guarantee regarding the suitability of the products for any particular purpose or the continuing production of any product. To the maximum extent permitted by applicable law, Vishay disclaims (i) any and all liability arising out of the application or use of any product, (ii) any and all liability, including without limitation special, consequential or incidental damages, and (iii) any and all implied warranties, including warranties of fitness for particular purpose, non-infringement and merchantability.

Statements regarding the suitability of products for certain types of applications are based on Vishay's knowledge of typical requirements that are often placed on Vishay products in generic applications. Such statements are not binding statements about the suitability of products for a particular application. It is the customer's responsibility to validate that a particular product with the properties described in the product specification is suitable for use in a particular application. Parameters provided in datasheets and / or specifications may vary in different applications and performance may vary over time. All operating parameters, including typical parameters, must be validated for each customer application by the customer's technical experts. Product specifications do not expand or otherwise modify Vishay's terms and conditions of purchase, including but not limited to the warranty expressed therein.

Hyperlinks included in this datasheet may direct users to third-party websites. These links are provided as a convenience and for informational purposes only. Inclusion of these hyperlinks does not constitute an endorsement or an approval by Vishay of any of the products, services or opinions of the corporation, organization or individual associated with the third-party website. Vishay disclaims any and all liability and bears no responsibility for the accuracy, legality or content of the third-party website or for that of subsequent links.

Vishay products are not designed for use in life-saving or life-sustaining applications or any application in which the failure of the Vishay product could result in personal injury or death unless specifically qualified in writing by Vishay. Customers using or selling Vishay products not expressly indicated for use in such applications do so at their own risk. Please contact authorized Vishay personnel to obtain written terms and conditions regarding products designed for such applications.

No license, express or implied, by estoppel or otherwise, to any intellectual property rights is granted by this document or by any conduct of Vishay. Product names and markings noted herein may be trademarks of their respective owners.