

# Data Sheet | Item Number: 831-3622

THT male header; 1.0 x 1.2 mm solder pin; angled; 100% protected against mismatching;

Pin spacing 7.62 mm; 2-pole; light gray

<https://www.wago.com/831-3622>

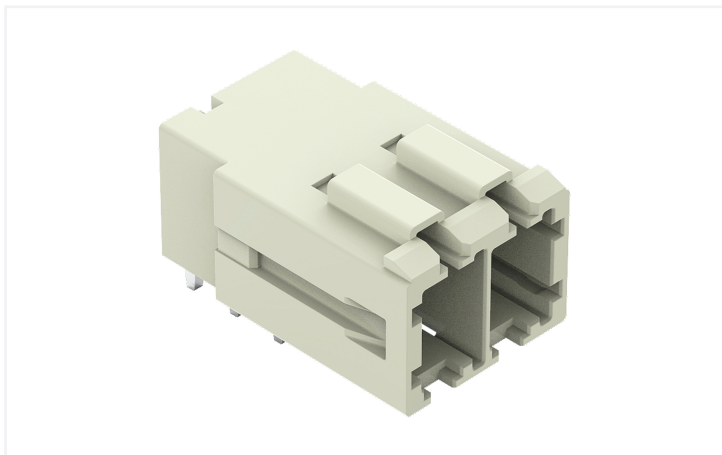

Color: ■ light gray

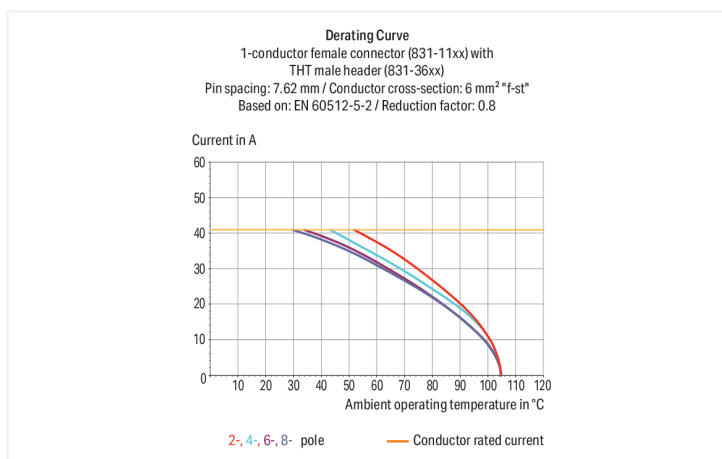
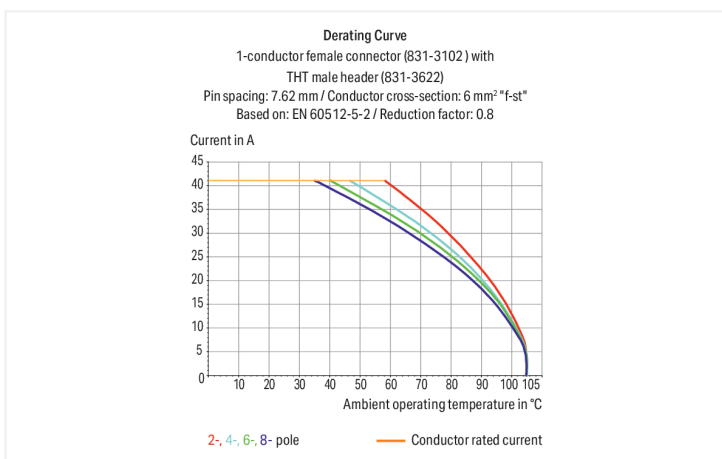
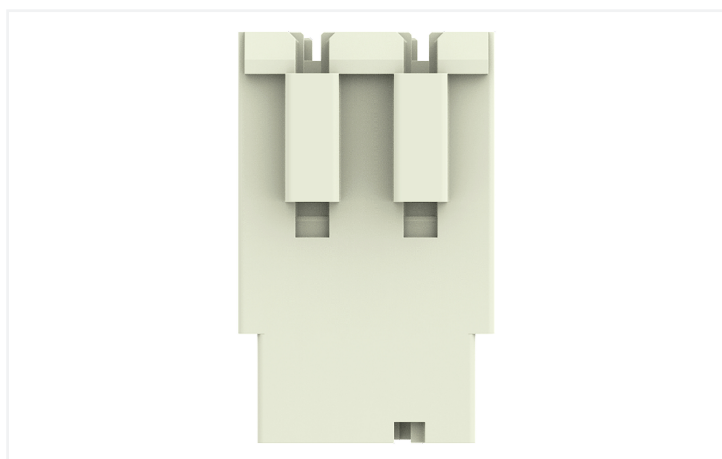
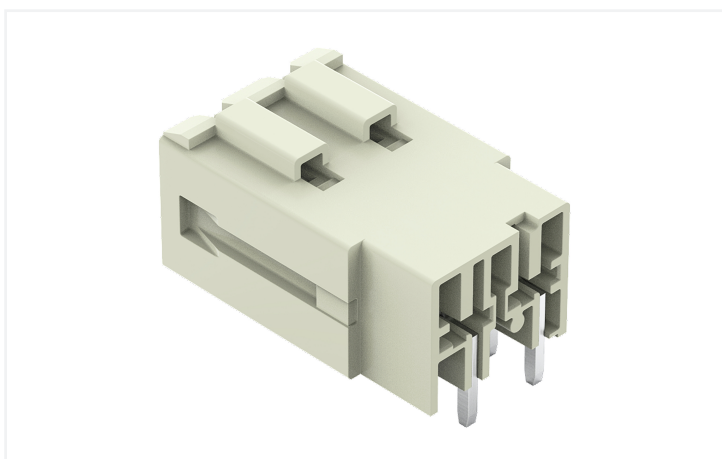

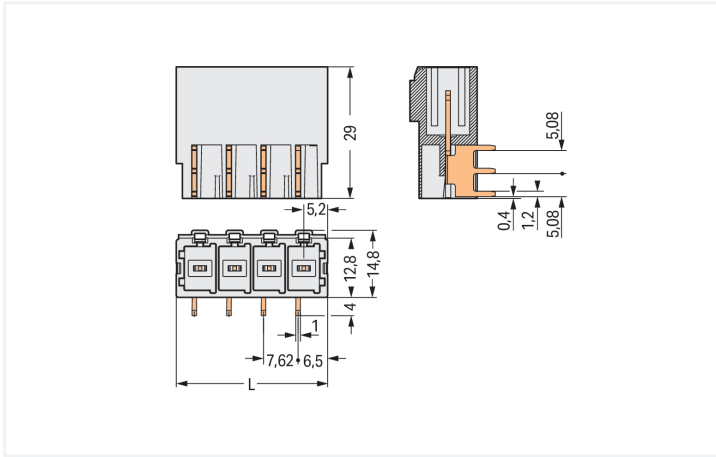

Dimensions in mm

L = (pole no. - 1) x pin spacing + 10.5 mm

Male connector, 831 Series, with 7.62 mm pin spacing

Our male connector (item number 831-3622) ensures effortless electrical installations. The dimensions are (18.12 x 18.8 x 29) mm (width x height x depth).

Tin is used for coating the contact surfaces. The pcb connector is designed for THT soldering.

**Notes**

**Safety Information**

The MCS – MULTI CONNECTION SYSTEM includes connectors without breaking capacity in accordance with DIN EN 61984. When used as intended, these connectors must not be connected/disconnected when live or under load. When used as intended, these connectors must not be connected/disconnected when live or under load. The circuit design should ensure header pins, which can be touched, are not live when unmated.

**Variants:**

Other pole numbers  
 Protection against PCB mounting errors  
 Other versions (or variants) can be requested from WAGO Sales or configured at <https://configurator.wago.com/>.

**Electrical data**

Ratings per	IEC/EN 60664-1		
Overvoltage category	III	III	II
Pollution degree	3	2	2
Nominal voltage	500 V	630 V	1000 V
Rated impulse withstand voltage	6 kV	6 kV	6 kV
Rated current	41 A	41 A	41 A

Approvals per	UL 1059		
Use group	B	C	D
Rated voltage	-	300 V	600 V
Rated current	-	42 A	5 A

Approvals per	CSA		
Use group	B	C	D
Rated voltage	-	300 V	600 V
Rated current	-	41 A	5 A

**Connection Data**

Total number of potentials	2
Number of connection types	1
Number of levels	1

Connection 1	
Pole number	2

### Physical data

Pin spacing	7.62 mm / 0.3 inches
Width	18.12 mm / 0.713 inches
Height	18.8 mm / 0.74 inches
Height from the surface	14.8 mm / 0.583 inches
Depth	29 mm / 1.142 inches
Solder pin length	4 mm
Solder pin dimensions	1 x 1.2 mm
Drilled hole diameter	1.7 <sup>(+0.1)</sup> mm

### Mechanical data

Variable coding	Yes
Anti-rotation protection	Yes

### Plug-in connection

Contact type (pluggable connector)	Male connector/plug
Connector (connection type)	for PCB
Mismating protection	Yes
Mating direction to the PCB	0°

### PCB contact

PCB contact	THT
Solder pin arrangement	over the entire male connector (in-line)
Number of solder pins per potential	3

### Material data

Note (material data)	<a href="#">Information on material specifications can be found here</a>
Color	light gray
Material group	I
Insulation material (main housing)	Polyamide (PA66)
Flammability class per UL94	V0
Contact material	Electrolytic copper (E <sub>Cu</sub> )
Contact Plating	Tin
Fire load	0.092 MJ
Weight	5.7 g

### Environmental requirements

Limit temperature range	-60 ... +105 °C	<h4>Environmental Testing</h4>	
Processing temperature	-35 ... +60 °C		
		Test specification: Railway applications – Rolling stock – Electronic equipment	DIN EN 50155 (VDE 0115-200):2022-06
		Test procedure: Railway applications – Rolling stock equipment – Vibration and shock tests	DIN EN 61373 (VDE 0115-0106):2011-04
		Spectrum/Mounting location	Service life test, Category 1, Class A/B
		Functional test with noise-like oscillations	Test passed according to Section 8 of the standard
		Frequency	f <sub>1</sub> = 5 Hz to f <sub>2</sub> = 150 Hz
		Acceleration	0.101g (highest test level used for all axes)
		Test duration per axis	10 min.
		Test directions	X, Y and Z axes

**Environmental Testing**

Monitoring of contact faults and interruptions	Passed
Voltage drop measurement before and after each axis	Passed
Simulated service life test through increased levels of noise-like oscillations	Test passed according to Section 9 of the standard
Frequency	$f_1 = 5 \text{ Hz}$ to $f_2 = 150 \text{ Hz}$
Acceleration	0.572g (highest test level used for all axes)
Test duration per axis	5 h
Test directions	X, Y and Z axes
Extended testing: Monitoring of contact faults and interruptions	Passed
Extended testing: Voltage drop measurement before and after each axis	Passed
Shock test	Test passed according to Section 10 of the standard
Shock pulse form	Half sine
Acceleration	5g (highest test level used for all axes)
Shock duration	30 ms
Number of shocks (per axis)	3 pos. und 3 neg.
Test directions	X, Y and Z axes
Extended testing: Monitoring of contact faults and interruptions	Passed
Extended testing: Voltage drop measurement before and after each axis	Passed
Vibration and shock stress for rolling stock equipment	Passed

**Commercial data**

Product Group	3 (Multi Conn. System)
PU (SPU)	48 pcs
Packaging type	Box
Country of origin	PL
GTIN	4045454002176
Customs tariff number	85366930000

**Product Classification**

UNSPSC	39121409
eCl@ss 10.0	27-44-04-02
eCl@ss 9.0	27-44-04-02
ETIM 9.0	EC002637
ETIM 10.0	EC002637
ECCN	NO US CLASSIFICATION

**Environmental Product Compliance**

RoHS Compliance Status	Compliant, No Exemption
------------------------	-------------------------

**Approvals / Certificates**

**General approvals**



Approval	Standard	Certificate Name
CB DEKRA Certification B.V.	IEC 61984	NL-124478
CSA DEKRA Certification B.V.	C22.2	1466354
KEMA/KEUR DEKRA Certification B.V.	EN 61984	71-129589 REV.1
UR Underwriters Laboratories Inc.	UL 1059	UL-US-2426356-0

**Declarations of conformity and manufacturer's declarations**



Approval	Standard	Certificate Name
Railway WAGO GmbH & Co. KG	-	Railway Ready

**Approvals for marine applications**



Approval	Standard	Certificate Name
LR Lloyds Register	IEC 61984	96/20035 (E5)

**Downloads**

**Environmental Product Compliance**

**Compliance Search**

Environmental Product Compliance 831-3622	↓
---	---

**Documentation**

**Additional Information**

Technical Section	03.04.2019	pdf 2027.26 KB	↓
-------------------	------------	-------------------	---

**CAD/CAE-Data**

**CAD data**

2D/3D Models 831-3622	↓
-----------------------	---

**CAE data**

EPLAN Data Portal 831-3622	↓
ZUKEN Portal 831-3622	↓

**PCB Design**

Symbol and Footprint via SamacSys 831-3622



Symbol and Footprint via Ultra Librarian 831-3622



**1 Compatible Products**

**1.1 System counterpart**

**1.1.1 Female connector/socket**



**Item No.: 831-1102**

1-conductor female connector; lever; Push-in CAGE CLAMP®; 10 mm²; Pin spacing 7.62 mm; 2-pole; 100% protected against mis-mating; 10,00 mm²; light gray



**Item No.: 831-1102/000-004**

1-conductor female connector; lever; Push-in CAGE CLAMP®; 10 mm²; Pin spacing 7.62 mm; 2-pole; 100% protected against mis-mating; black



**Item No.: 831-1102/322-000**

1-conductor female connector; lever; Push-in CAGE CLAMP®; 10 mm²; Pin spacing 7.62 mm; 2-pole; 100% protected against mis-mating; Centered locking levers; 10,00 mm²; light gray



**Item No.: 831-1102/322-004**

1-conductor female connector; lever; Push-in CAGE CLAMP®; 10 mm²; Pin spacing 7.62 mm; 2-pole; 100% protected against mis-mating; Centered locking levers; black



**Item No.: 831-1102/133-000**

1-conductor female connector; lever; Push-in CAGE CLAMP®; 10 mm²; Pin spacing 7.62 mm; 2-pole; 100% protected against mis-mating; Gripping plate; 10,00 mm²; light gray



**Item No.: 831-1102/037-000**

1-conductor female connector; lever; Push-in CAGE CLAMP®; 10 mm²; Pin spacing 7.62 mm; 2-pole; 100% protected against mis-mating; Lateral locking levers; 10,00 mm²; light gray



**Item No.: 831-1102/038-000**

1-conductor female connector; lever; Push-in CAGE CLAMP®; 10 mm²; Pin spacing 7.62 mm; 2-pole; 100% protected against mis-mating; Lateral locking levers; 10,00 mm²; light gray



**Item No.: 831-3102**

1-conductor female connector; Push-in CAGE CLAMP®; 10 mm²; Pin spacing 7.62 mm; 2-pole; 100% protected against mis-mating; 10,00 mm²; light gray



**Item No.: 831-3102/000-9037**

1-conductor female connector; Push-in CAGE CLAMP®; 10 mm²; Pin spacing 7.62 mm; 2-pole; 100% protected against mis-mating; direct marking; 10,00 mm²; light gray



**Item No.: 831-3102/133-000**

1-conductor female connector; Push-in CAGE CLAMP®; 10 mm²; Pin spacing 7.62 mm; 2-pole; 100% protected against mis-mating; Gripping plate; 10,00 mm²; light gray



**Item No.: 831-3102/037-000**

1-conductor female connector; Push-in CAGE CLAMP®; 10 mm²; Pin spacing 7.62 mm; 2-pole; 100% protected against mis-mating; Lateral locking levers; 10,00 mm²; light gray



**Item No.: 831-3102/037-9037**

1-conductor female connector; Push-in CAGE CLAMP®; 10 mm²; Pin spacing 7.62 mm; 2-pole; 100% protected against mis-mating; Lateral locking levers; direct marking; 10,00 mm²; light gray



**Item No.: 831-3522**

THT female header; angled; Pin spacing 7.62 mm; 2-pole; 100% protected against mis-mating; 1.0 x 1.2 mm solder pin; light gray



**Item No.: 831-3502**

THT female header; straight; Pin spacing 7.62 mm; 2-pole; 100% protected against mis-mating; 1.0 x 1.2 mm solder pin; light gray

**1.2 Optional Accessories**

**1.2.1 Coding**

**1.2.1.1 Coding**



**Item No.: 831-500**

Coding pin carrier with six coding pins; orange

## Installation Notes

### Coding

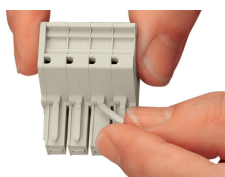

Break or cut off coding pin from female connector.

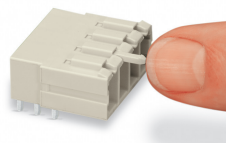

Insert coding pin into male header (break first) until it engages.

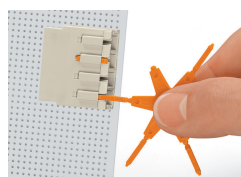

Coding a THT male header by inserting a coding pin.