

# Customer Information Sheet

DRAWING No.: M300-2241096F2

IF IN DOUBT - ASK

©

NOT TO SCALE

THIRD ANGLE PROJECTION

ALL DIMENSIONS IN mm

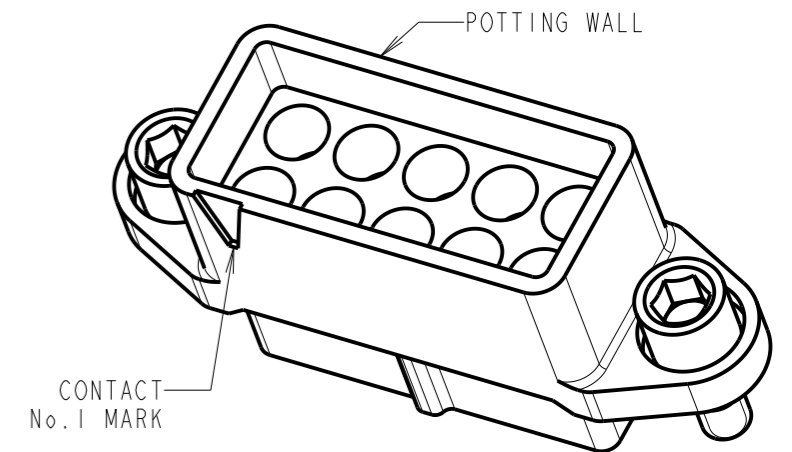
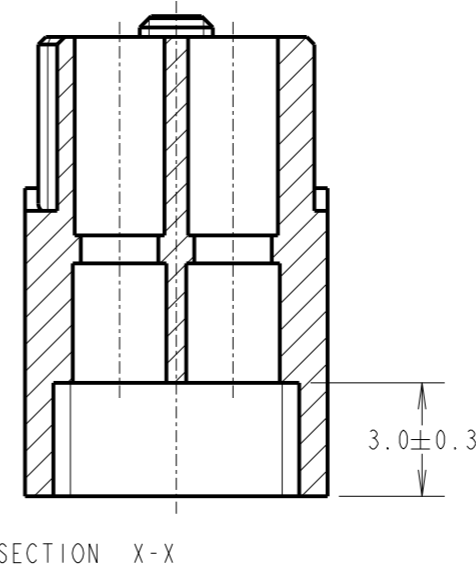
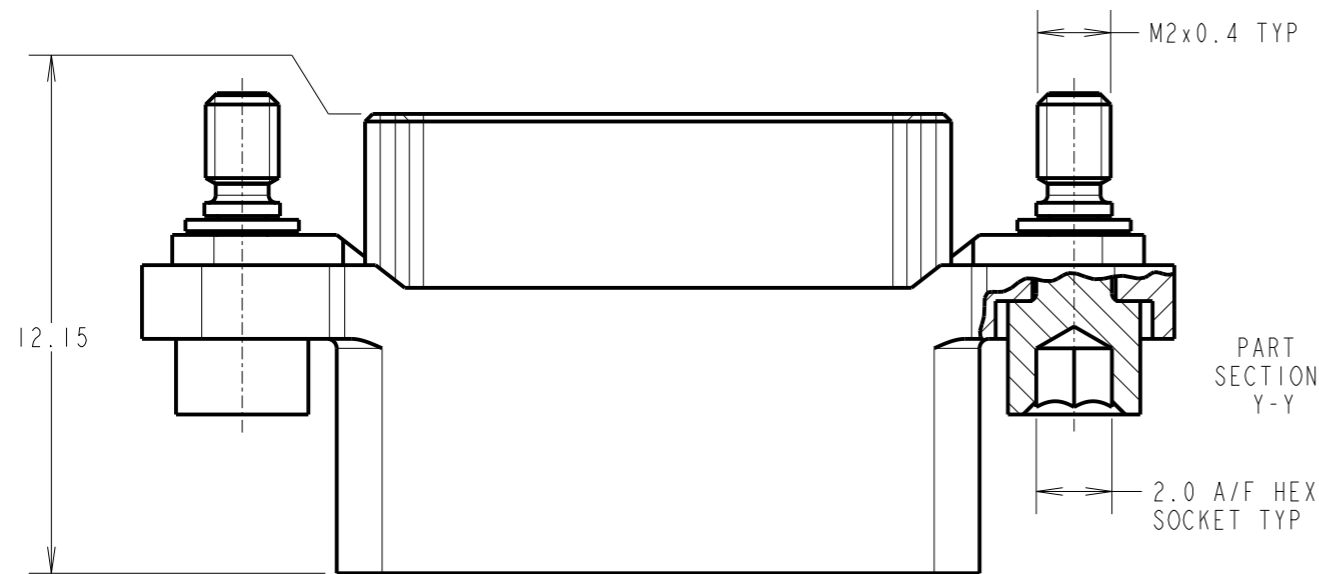
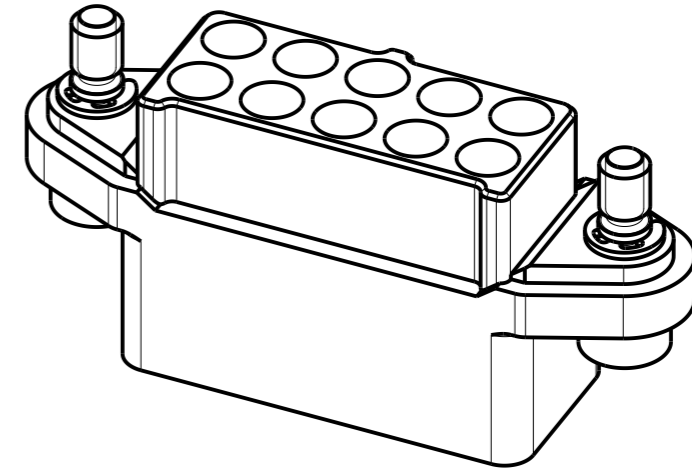
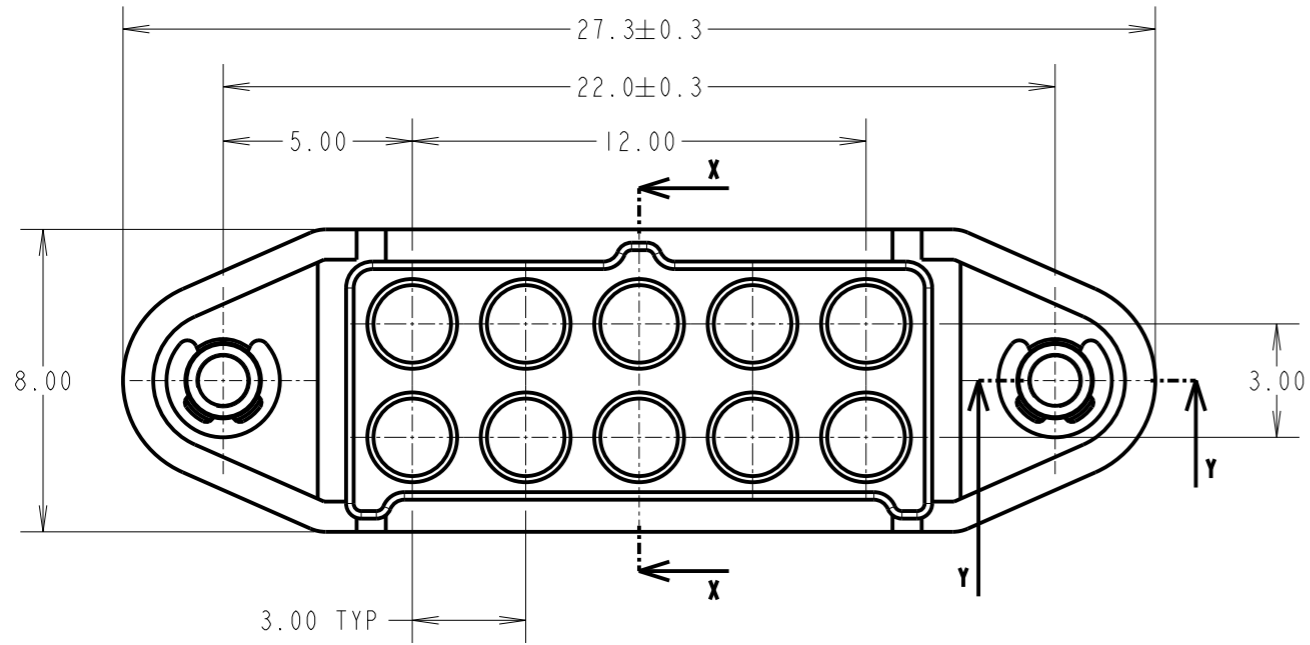

RTP	2	09.12.21	31253
NAME	ISS.	DATE	CN/CO
APPROVED: R.PORTLOCK			
CHECKED: M.RUDKIN			
DRAWN: MARK G PLESTED			
CUSTOMER REF.:			
ASSEMBLY DRG:			

- NOTES:  
 1. FOR USE WITH M300-0010045 & M300-0020045 CONTACTS (NOT INCLUDED).  
 2. SEE COMPONENT SPECIFICATION CO48XX (LATEST ISSUE) FOR PRODUCT SPECIFICATION AND WIRING/CRIMPING ASSEMBLY INSTRUCTIONS.

**HARWIN**

www.harwin.com  
 technical@harwin.com

THIS DRAWING AND ANY INFORMATION OR DESCRIPTIVE MATTER SET OUT HEREON ARE CONFIDENTIAL AND COPYRIGHT PROPERTY OF THE HARWIN GROUP AND MUST NOT BE DISCLOSED, LOANED, COPIED OR USED FOR MANUFACTURING, TENDERING OR FOR ANY OTHER PURPOSE WITHOUT THEIR WRITTEN PERMISSION.

TOLERANCES  
 X. = ±1mm  
 X.X = ±0.50mm  
 X.XX = ±0.20mm  
 X.XXX = ±0.01mm  
 ANGLES = ±5°  
 UNLESS STATED

MATERIAL:  
 SEE ABOVE  
 FINISH: SEE ABOVE  
 S/AREA: mm<sup>2</sup>

TITLE: 1mm POWER CONNECTOR  
 DIL CRIMP HOUSING WITH  
 POTTING WALL FEMALE ASSEMBLY  
 DRAWING NUMBER:  
**M300-2241096F2**  
 SHT 2 OF 2