

REVISIONS					
REV	ECO	DESCRIPTION	DATE	BY	APPR
A1		RELEASE DRAWING	15MAR20	SULLENTOMMY	

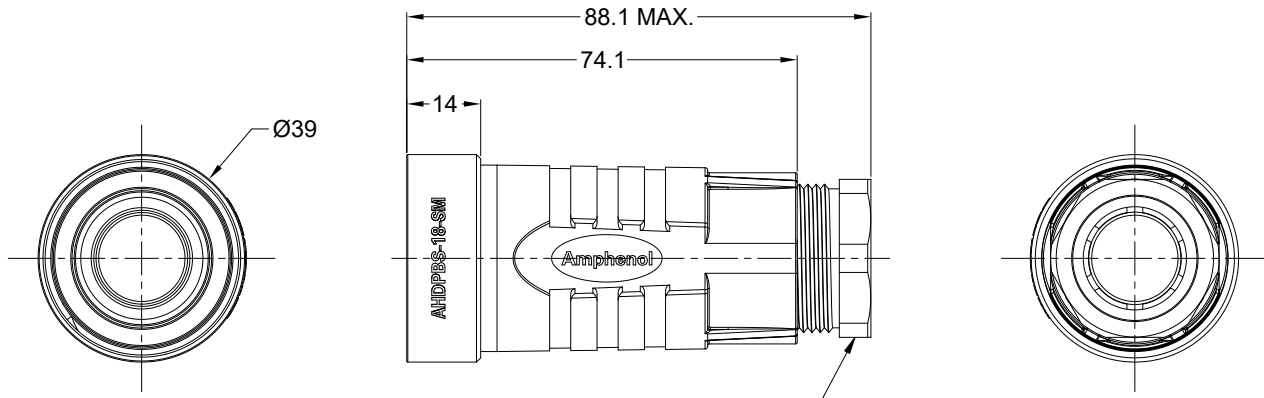

SCREW CONNECTION
TIGHTENING TORQUE 2.5-3Nm

1 7/16-12 UN-2B
THREAD

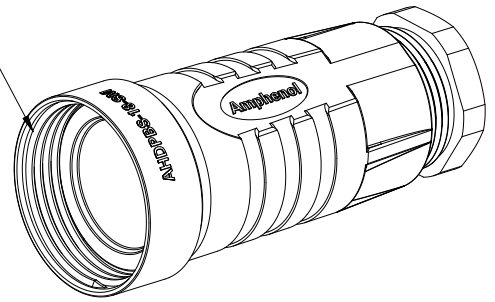

REAR RUBBER RING ID	CABLE OD RANGE
Ø16.5MM	Ø13.0-16.0MM

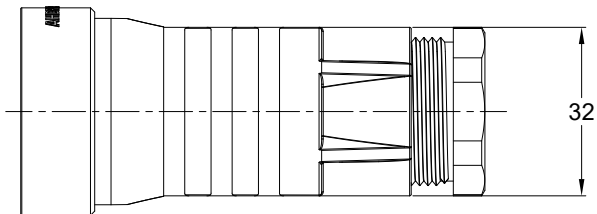

NOTES: UNLESS OTHERWISE SPECIFIED

- MATERIAL:
BACK SHELL: THERMOPLASTIC
RUBBER RING: SILICONE RUBBER
CAGE CLAMP: THERMOPLASTIC
PRESSURE NUT: THERMOPLASTIC
- COLORS: BLACK
- RoHS COMPLIANT
- USE WITH SIZE 18 AHDP SERIES WTA MODIFICATION
- ALL DIMENSIONS ARE FOR REFERENCE USE ONLY.

AHDPBS-18-SM01		DESCRIPTION		ITEM
PART NUMBER		DESCRIPTION		ITEM
QUANTITY	MATERIALS LIST			
UNLESS OTHERWISE SPECIFIED		SIGNATURES		DATE
1) All dimensions are in metric(mm).		DRAWN: SULENZHANG	15MAR20	
2) Tolerances are as follows:		CHECKED: ORION.LI	16MAR20	
1 PL DEC ±0.30		ENGINEER:		
2 PL DEC ±0.15		APPROVAL: TOMMY.XIE	17MAR20	
3 PL DEC ±0.08		CUSTOMER:		
3) Note reference =		THIS DRAWING IS SUPPLIED FOR INFORMATION ONLY. DESIGN FEATURES, SPECIFICATIONS AND PERFORMANCE DATA SHOWN HEREON ARE THE PROPERTY OF THE AMPHENOL CORPORATION. NO RIGHTS OF REPRODUCTION ARE IMPLIED. ALL DIMENSIONS ARE SUBJECT TO NORMAL MANUFACTURING VARIATIONS.		
MATERIAL SPECIFICATIONS:		Sine Systems - www.amphenol-sine.com 44724 Morley Drive Clinton Township, MI 48036		
PROCESS SPECIFICATIONS:		BACKSHELL, SIZE 18, AHDP		
NEXT ASSY:		SIZE	TYPE	DWG NO:
		A	C-	AHDPBS-18-SM01
		SCALE: NONE		REVISION A1
				SHEET 1 OF 1