

SG-V0418  
JG-72397

REV	DOCUMENT	CHANGED BY	CHECK
5	0088095	SBH 29MAR12	CMH

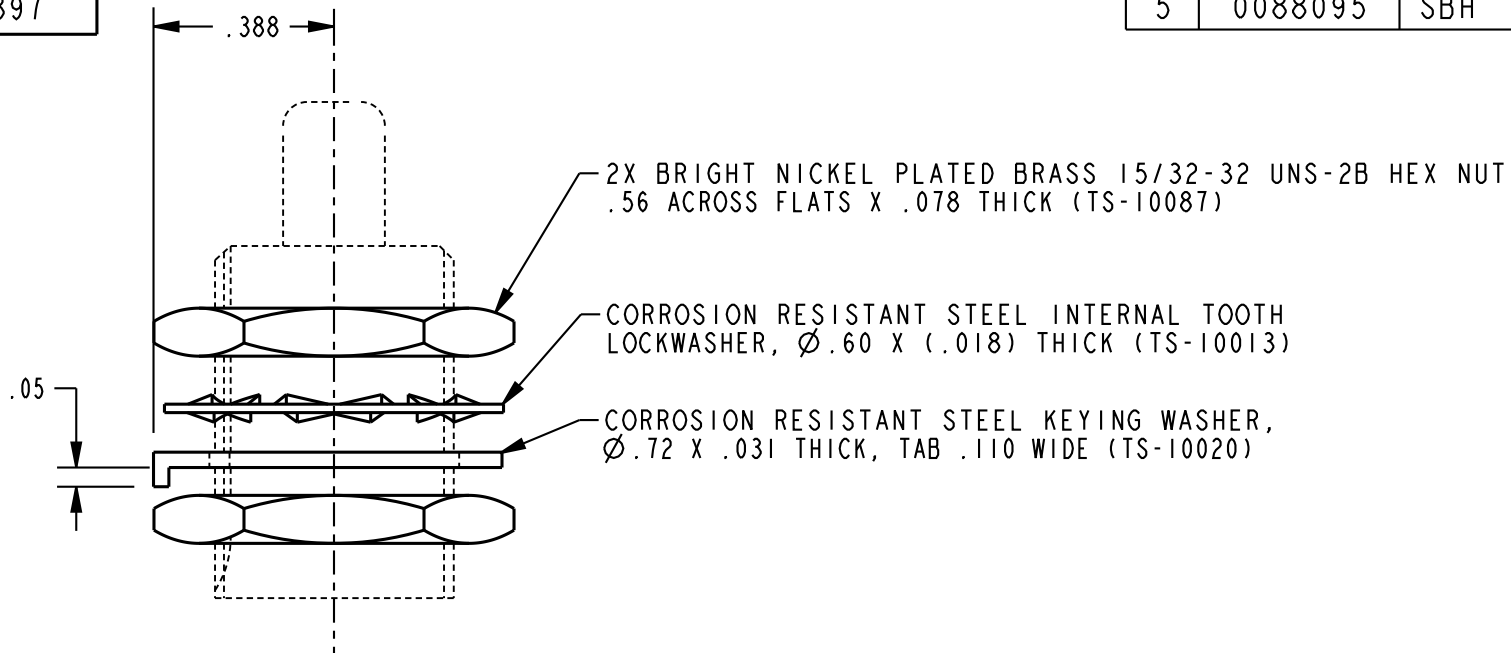

- NOTES
- 1 - PARTS FURNISHED UNASSEMBLED AS PACKET
  - 2 - THIS PACKET MAY BE USED WITH ANY FAMILY OF SWITCHES WHICH HAVE A 15/32-32 UNS-2A THREADED BUSHING
  - 3 - PACKED IN CLEAR PLASTIC BAG WITH HOLES TO FIT OVER BUSHING

UNLESS OTHERWISE SPECIFIED TOLERANCES ARE:

	<input checked="" type="checkbox"/> US (inch) CUSTOMARY	<input type="checkbox"/> SI (mm) METRIC
NO PLACE	X	±.040 ±1
ONE PLACE	.X	±.030 ±0,4
TWO PLACE	.XX	±.015 ±0,15
THREE PLACE	.XXX	±.005 ±
ANGLES		± ±
RAW MATERIAL-COMMERCIAL STANDARD		

DRAWN	TSM	15AUG01
CHECK	SAV	15AUG01

**Honeywell**

THIS DRAWING COVERS A PROPRIETARY ITEM AND IS THE PROPERTY OF HONEYWELL. THIS DRAWING IS NOT TO BE COPIED OR USED WITHOUT THE PERMISSION OF HONEYWELL.

TITLE			
<b>PACKET</b>			

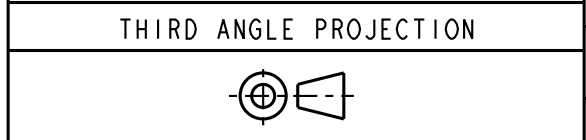

DIMENSIONS ARE TO BE MET BEFORE PROTECTIVE COATINGS ARE APPLIED		
PTC 2D	ASME Y14.5M-1994	

SIZE	DWG TYPE	DRAWING NAME	REV
<b>A</b>	<b>I</b>	<b>15PA312-AT</b>	<b>5</b>
SCALE 2 : 1		WEIGHT	SHEET 1 OF 1