

100 V, 40 A power Schottky rectifier

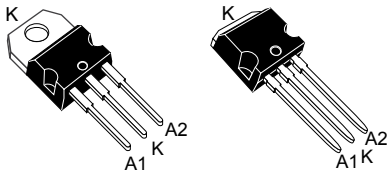

TO-220AB

I²PAK

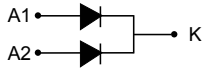
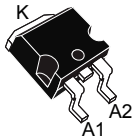

D²PAK

Features

- Negligible switching losses
- Low leakage current
- Good trade-off between leakage current and forward voltage drop
- Low thermal resistance
- Avalanche specification
- ECOPACK2 compliant

Applications

- Switch mode power supply (SMPS)
- DC/DC converter
- LED lighting
- Auxiliary power supply

Description

This dual center tab Schottky rectifier is suited for switch mode power supply and high frequency DC to DC converters.

Packaged in D²PAK, I²PAK and TO-220AB, the STPS41H100C is optimized for use in high frequency inverters.

Product status link

[STPS41H100C](#)

Product summary

| Symbol | Value |
|--------------|----------|
| $I_{F(AV)}$ | 2 x 20 A |
| V_{RRM} | 100 V |
| T_j | 175 °C |
| V_F (typ.) | 0.62 V |

1 Characteristics

Table 1. Absolute ratings (limiting values, per diode, at 25 °C, unless otherwise specified)

| Symbol | Parameter | Value | Unit | | |
|---------------------|---|--|-------------|----|---|
| V _{RRM} | Repetitive peak reverse voltage | 100 | V | | |
| I _{F(RMS)} | Forward rms current | 30 | A | | |
| I _{F(AV)} | Average forward current, $\delta = 0.5$ square wave | T _c = 150 °C | Per diode | 20 | A |
| | | | Per device | 40 | |
| I _{FSM} | Surge non repetitive forward current | t _p = 10 ms sinusoidal | 220 | A | |
| P _{ARM} | Repetitive peak avalanche power | t _p = 10 μ s, T _j = 125 °C | 1300 | W | |
| T _{stg} | Storage temperature range | | -65 to +175 | °C | |
| T _j | Maximum operating junction temperature range ⁽¹⁾ | | 175 | °C | |

1. $(dP_{tot}/dT_j) < (1/R_{th(j-a)})$ condition to avoid thermal runaway for a diode on its own heatsink.

Table 2. Thermal resistance parameters

| Symbol | Parameter | Max. value | Unit |
|----------------------|------------------|------------|------|
| R _{th(j-c)} | Junction to case | Per diode | 1.5 |
| | | Total | 0.8 |
| R _{th(c)} | Coupling | 0.1 | °C/W |

When the diodes 1 and 2 are used simultaneously :

$$\Delta T_j(\text{diode 1}) = P(\text{diode1}) \times R_{th(j-c)}(\text{per diode}) + P(\text{diode 2}) \times R_{th(c)}$$

For more information, you can refer to the following application note:

- [AN5088](#): Rectifiers thermal management, handling and mounting recommendations

Table 3. Static electrical characteristics (per diode)

| Symbol | Parameter | Test conditions | Min. | Typ. | Max. | Unit | |
|-------------------------------|-------------------------|-------------------------|-----------------------------------|------|------|------|---------|
| I _R ⁽¹⁾ | Reverse leakage current | T _j = 25 °C | V _R = V _{RRM} | - | | 10 | μ A |
| | | T _j = 125 °C | | - | 3 | 10 | mA |
| V _F ⁽²⁾ | Forward voltage drop | T _j = 25 °C | I _F = 20 A | - | | 0.80 | V |
| | | T _j = 125 °C | | - | 0.62 | 0.67 | |
| | | T _j = 25 °C | I _F = 40 A | - | | 0.90 | |
| | | T _j = 125 °C | | - | 0.70 | 0.76 | |

1. Pulse test: t_p = 5 ms, $\delta < 2\%$

2. Pulse test: t_p = 380 μ s, $\delta < 2\%$

To evaluate the conduction losses, use the following equation: $P = 0.58 \times I_{F(AV)} + 0.0045 \times I_{F(RMS)}^2$

For more information, you can refer to the following application notes related to the power losses :

- [AN604](#): Calculation of conduction losses in a power rectifier
- [AN4021](#): Calculation of reverse losses on a power diode

1.1 Characteristics (curves)

Figure 1. Average forward power dissipation versus average forward current (per diode)

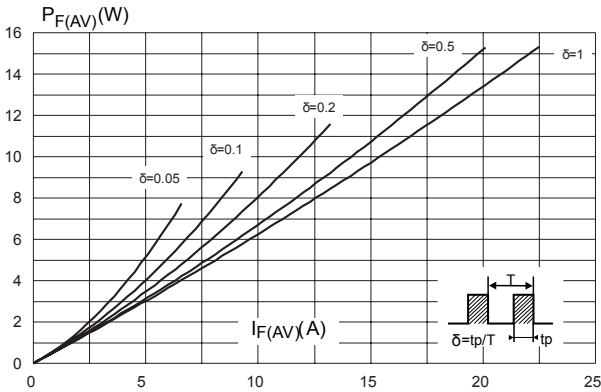

Figure 2. Average forward current versus ambient temperature ($\delta = 0.5$, per diode)

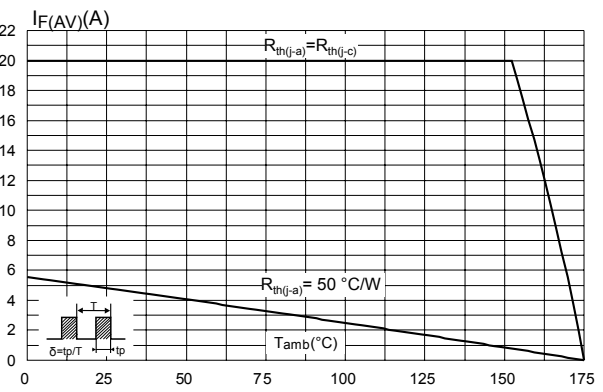

Figure 3. Normalized avalanche power derating versus pulse duration ($T_j = 125^\circ\text{C}$)

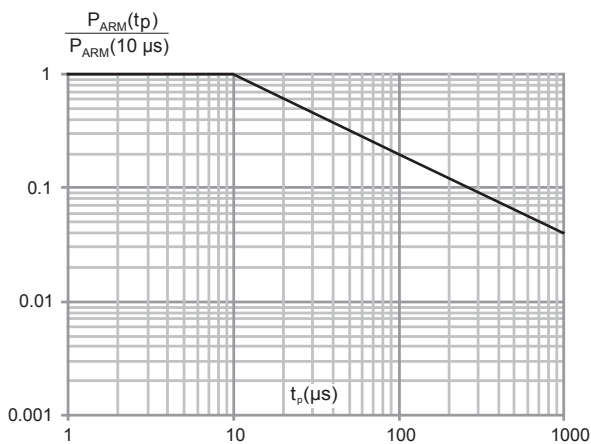

Figure 4. Relative variation of thermal impedance junction to case versus pulse duration

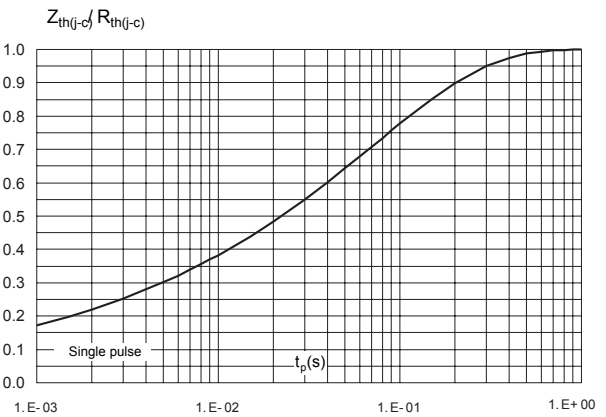

Figure 5. Reverse leakage current versus reverse voltage applied (typical values, per diode)

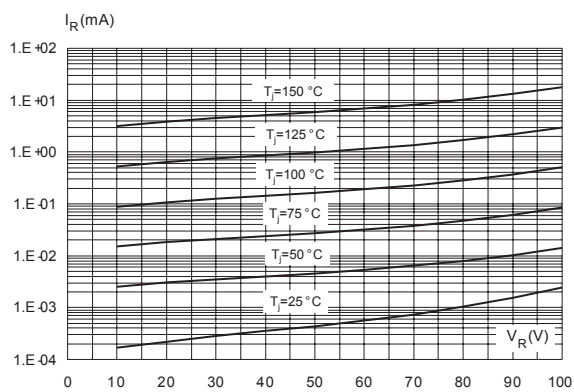

Figure 6. Junction capacitance versus reverse voltage applied (typical values, per diode)

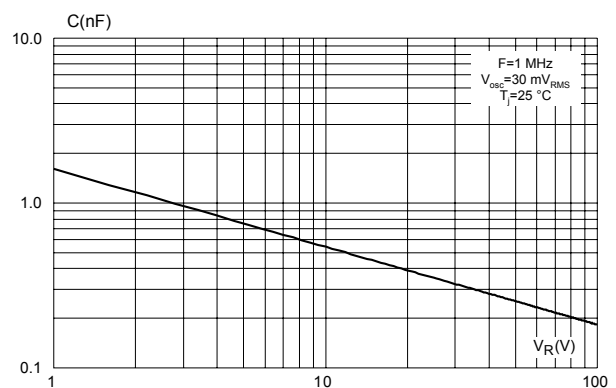

Figure 7. Forward voltage drop versus forward current (per diode)

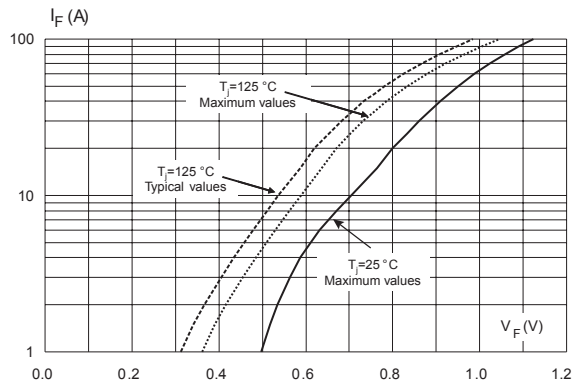
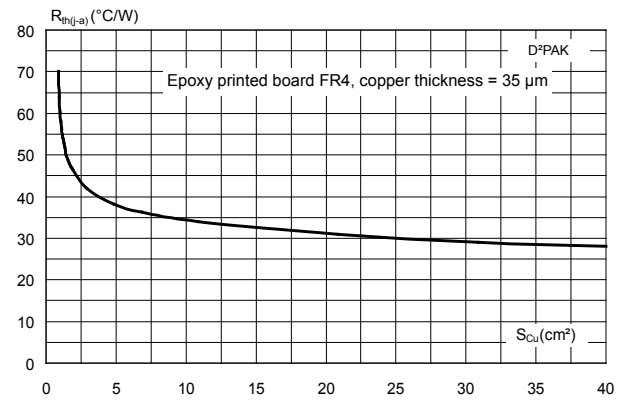

Figure 8. Thermal resistance junction to ambient versus copper surface under tab



2 Package information

To meet environmental requirements, ST offers these devices in different grades of **ECOPACK** packages, depending on their level of environmental compliance. ECOPACK specifications, grade definitions, and product status are available at: www.st.com. ECOPACK is an ST trademark.

2.1 TO-220AB package information

- Molding compounded resin is halogen free and meets UL94 flammability standard, level V0
- Lead-free package leads plating
- Cooling method: by conduction (C)
- Recommended torque value: 0.55 N·m
- Maximum torque value: 0.70 N·m

Figure 9. TO-220AB package outline

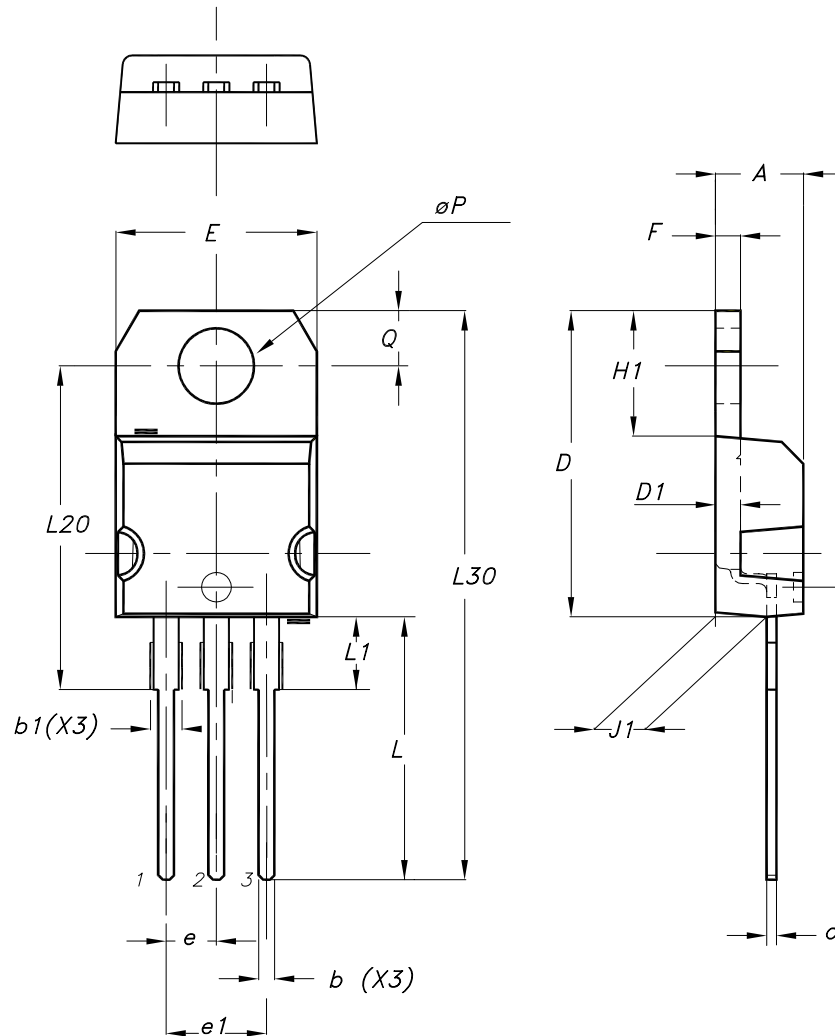

0015988_1_24

Table 4. TO-220AB package mechanical data

| Ref. | Dimensions | | | |
|------|-------------|-------|-----------------------------|-------|
| | Millimeters | | Inches (for reference only) | |
| | Min. | Max. | Min. | Max. |
| A | 4.40 | 4.60 | 0.173 | 0.181 |
| b | 0.61 | 0.88 | 0.240 | 0.035 |
| b1 | 1.14 | 1.55 | 0.045 | 0.061 |
| c | 0.48 | 0.70 | 0.019 | 0.028 |
| D | 15.25 | 15.75 | 0.600 | 0.620 |
| D1 | 1.27 typ. | | 0.050 typ. | |
| E | 10.00 | 10.40 | 0.394 | 0.409 |
| e | 2.40 | 2.70 | 0.094 | 0.106 |
| e1 | 4.95 | 5.15 | 0.195 | 0.203 |
| F | 1.23 | 1.32 | 0.048 | 0.052 |
| H1 | 6.20 | 6.60 | 0.244 | 0.260 |
| J1 | 2.40 | 2.72 | 0.094 | 0.107 |
| L | 13.00 | 14.00 | 0.512 | 0.551 |
| L1 | 3.50 | 3.93 | 0.138 | 0.155 |
| L20 | 16.40 typ. | | 0.646 typ. | |
| L30 | 28.90 typ. | | 1.138 typ. | |
| θP | 3.75 | 3.85 | 0.148 | 0.152 |
| Q | 2.65 | 2.95 | 0.104 | 0.116 |

2.2 I²PAK package information

- Epoxy meets UL 94, V0
- Cooling method: by conduction (C)

Figure 10. I²PAK package outline

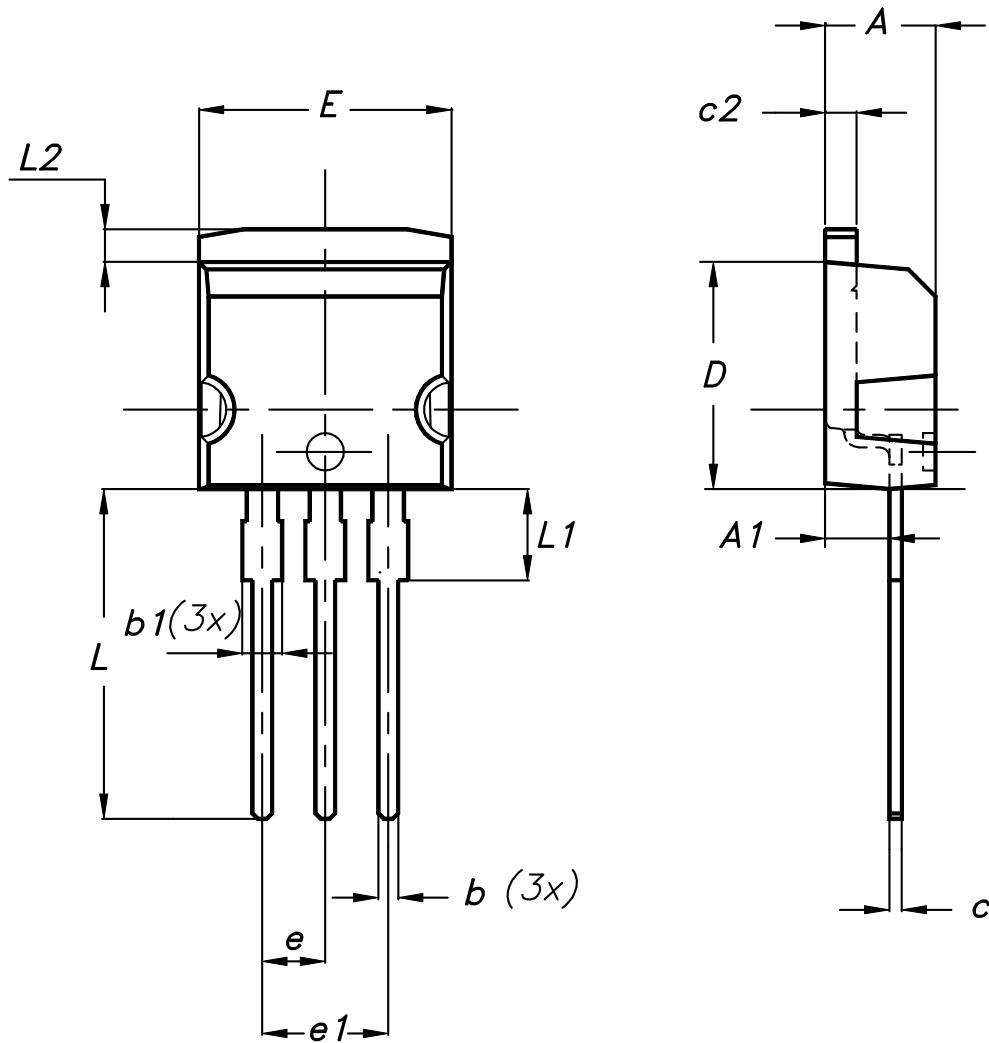

0004982_1_10

Table 5. I²PAK package mechanical data

| Ref. | Dimensions | | | |
|------|-------------|-------|-----------------------------|-------|
| | Millimeters | | Inches (for reference only) | |
| | Min. | Max. | Min. | Max. |
| A | 4.40 | 4.60 | 0.173 | 0.181 |
| A1 | 2.40 | 2.72 | 0.094 | 0.107 |
| b | 0.61 | 0.88 | 0.024 | 0.035 |
| b1 | 1.14 | 1.70 | 0.044 | 0.067 |
| c | 0.49 | 0.70 | 0.019 | 0.028 |
| c2 | 1.23 | 1.32 | 0.048 | 0.052 |
| D | 8.95 | 9.35 | 0.352 | 0.368 |
| e | 2.40 | 2.70 | 0.094 | 0.106 |
| e1 | 4.95 | 5.15 | 0.195 | 0.203 |
| E | 10.00 | 10.40 | 0.394 | 0.409 |
| L | 13.00 | 14.00 | 0.512 | 0.551 |
| L1 | 3.50 | 3.93 | 0.138 | 0.155 |
| L2 | 1.27 | 1.40 | 0.050 | 0.055 |

2.3 D²PAK package information

- Epoxy meets UL94, V0.
- Cooling method: by conduction (C)

Figure 11. D²PAK package outline

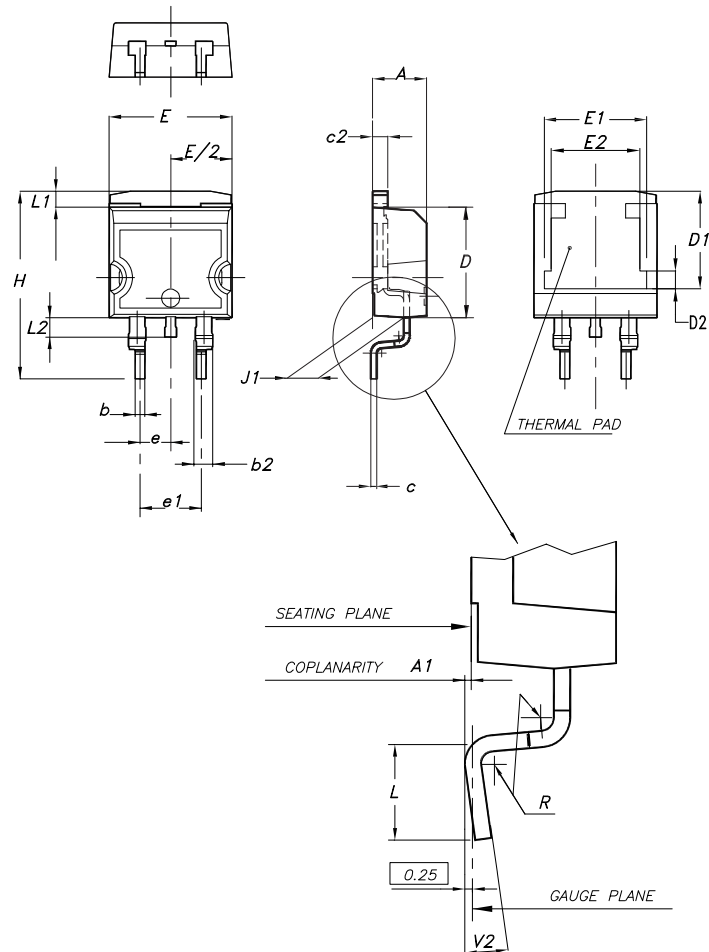

0079457_1_27

Note: This package drawing may slightly differ from the physical package. However, all the specified dimensions are guaranteed.

Table 6. D²PAK package mechanical data

| Ref. | Dimensions | | | | | |
|------|-------------|------|-------|-----------------------------|-------|-------|
| | Millimeters | | | Inches (for reference only) | | |
| | Min. | Typ. | Max. | Min. | Typ. | Max. |
| A | 4.40 | | 4.60 | 0.173 | | 0.181 |
| A1 | 0.03 | | 0.23 | 0.001 | | 0.009 |
| b | 0.70 | | 0.93 | 0.028 | | 0.037 |
| b2 | 1.14 | | 1.70 | 0.045 | | 0.067 |
| c | 0.45 | | 0.60 | 0.018 | | 0.024 |
| c2 | 1.23 | | 1.36 | 0.048 | | 0.053 |
| D | 8.95 | | 9.35 | 0.352 | | 0.368 |
| D1 | 7.50 | 7.75 | 8.00 | 0.295 | 0.305 | 0.315 |
| D2 | 1.10 | 1.30 | 1.50 | 0.043 | 0.051 | 0.060 |
| E | 10.00 | | 10.40 | 0.394 | | 0.409 |
| E1 | 8.30 | 8.50 | 8.70 | 0.326 | 0.334 | 0.343 |
| E2 | 6.85 | 7.05 | 7.25 | 0.266 | 0.278 | 0.282 |
| e | | 2.54 | | | 0.100 | |
| e1 | 4.88 | | 5.28 | 0.190 | | 0.205 |
| H | 15.00 | | 15.85 | 0.591 | | 0.624 |
| J1 | 2.49 | | 2.69 | 0.097 | | 0.106 |
| L | 2.29 | | 2.79 | 0.090 | | 0.110 |
| L1 | 1.27 | | 1.40 | 0.049 | | 0.055 |
| L2 | 1.30 | | 1.75 | 0.050 | | 0.069 |
| R | | 0.40 | | | 0.015 | |
| V2 | 0° | | 8° | 0° | | 8° |

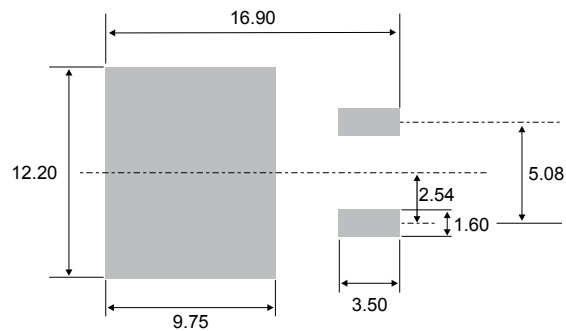
Figure 12. D²PAK recommended footprint (dimensions are in mm)

0079457_27

3 Ordering information

Table 7. Ordering information

| Order code | Marking | Package | Weight | Base qty. | Delivery mode |
|-----------------|--------------|--------------------|--------|-----------|---------------|
| STPS41H100CT | STPS41H100CT | TO-220AB | 1.95 g | 50 | Tube |
| STPS41H100CG | STPS41H100CG | D ² PAK | 1.38 g | 50 | Tube |
| STPS41H100CG-TR | STPS41H100CG | D ² PAK | 1.38 g | 1000 | Tape and reel |
| STPS41H100CR | STPS41H100CR | I ² PAK | 1.50 g | 30 | Tube |

Revision history

Table 8. Document revision history

| Date | Version | Changes |
|-------------|---------|--|
| Jul-2003 | 3A | Previous release. |
| 15-Jul-2011 | 4 | Updated Table 5. |
| 11-Apr-2012 | 5 | Removed order codes STPS41H100CR-H and STPS41H100CT-H. Replaced paragraph under Table 5. |
| 27-Jun-2018 | 6 | Updated Table 1. Absolute ratings (limiting values, per diode, at 25 °C, unless otherwise specified). Updated Section 1.1: Characteristics (curves). |
| 03-Apr-2026 | 7 | Updated Table 7. Minor text changes. |

IMPORTANT NOTICE – READ CAREFULLY

STMicroelectronics NV and its subsidiaries (“ST”) reserve the right to make changes, corrections, enhancements, modifications, and improvements to ST products and/or to this document at any time without notice.

In the event of any conflict between the provisions of this document and the provisions of any contractual arrangement in force between the purchasers and ST, the provisions of such contractual arrangement shall prevail.

The purchasers should obtain the latest relevant information on ST products before placing orders. ST products are sold pursuant to ST’s terms and conditions of sale in place at the time of order acknowledgment.

The purchasers are solely responsible for the choice, selection, and use of ST products and ST assumes no liability for application assistance or the design of the purchasers’ products.

No license, express or implied, to any intellectual property right is granted by ST herein.

Resale of ST products with provisions different from the information set forth herein shall void any warranty granted by ST for such product.

If the purchasers identify an ST product that meets their functional and performance requirements but that is not designated for the purchasers’ market segment, the purchasers shall contact ST for more information.

ST and the ST logo are trademarks of ST. For additional information about ST trademarks, refer to www.st.com/trademarks. All other product or service names are the property of their respective owners.

Information in this document supersedes and replaces information previously supplied in any prior versions of this document.

© 2026 STMicroelectronics – All rights reserved