

## Data Sheet | Item Number: 2604-3306

PCB terminal block; lever; 4 mm<sup>2</sup>; Pin spacing 7.5 mm; 6-pole; Push-in CAGE CLAMP®; gray

<https://www.wago.com/2604-3306>

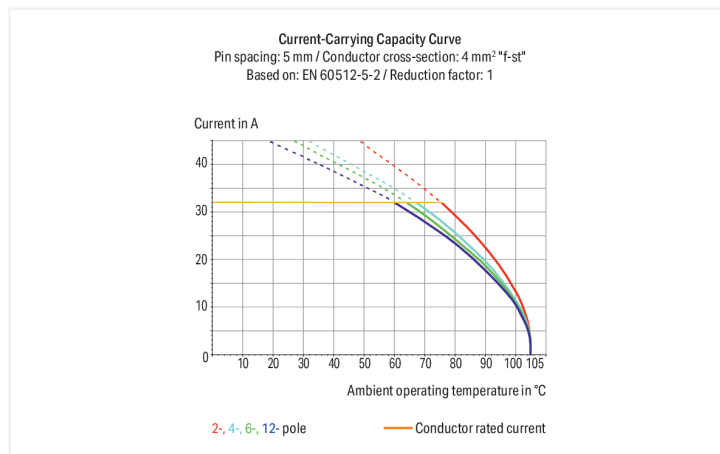
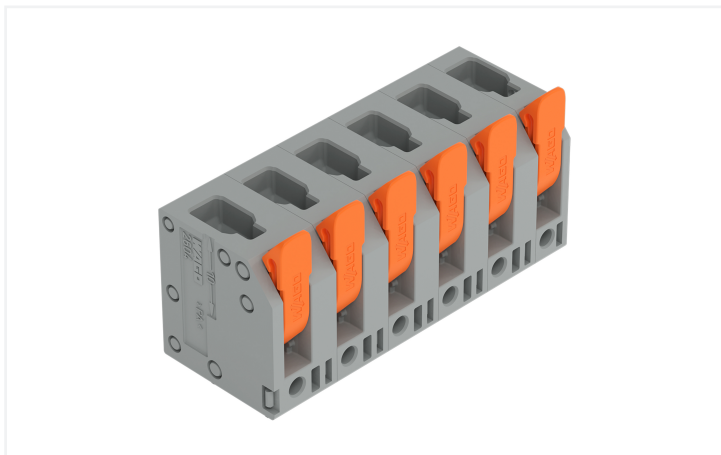

Color: ■ gray

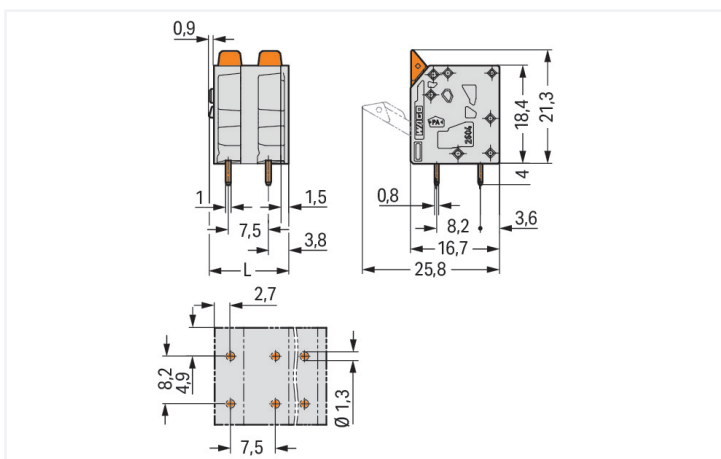

Dimensions in mm

L = (pole no. - 1) x pin spacing + 7.4 mm

PCB terminal block, 2604 Series, gray

This PCB terminal block (item number 2604-3306) streamlines wire connections, making them both quick and easy. It is perfect for custom installations with different mounting types. Conductors should only be connected to this PCB terminal block if their strip length is between 9 and 11 mm. This product features one conductor terminal and utilizes Push-in CAGE CLAMP®. Push-in CAGE CLAMP® connection technology is ideal for connecting all conductor types. It allows direct insertion of both solid and fine-stranded conductors with ferrules without needing to use any tools—all thanks to its pluggable design. The item's dimensions are (44.9 x 25.3 x 16.7) mm (width x height x depth). This PCB terminal block is suitable for conductor cross sections ranging from 0.2 mm<sup>2</sup> to 4 mm<sup>2</sup>. The contact surface is coated with tin. A lever is used to operate this PCB terminal block. The PCB terminal block is designed for THT soldering. Insert the conductor at an angle of 90°.

## Notes

Variants:	Other pole numbers Direct marking Other colors Other versions (or variants) can be requested from WAGO Sales or configured at <a href="https://configurator.wago.com/">https://configurator.wago.com/</a> .
-----------	--

## Electrical data

Ratings per	IEC/EN 60664-1			Approvals per	UL 1059		
Overvoltage category	III	III	II	Use group	B	C	D
Pollution degree	3	2	2	Rated voltage	300 V	300 V	600 V
Nominal voltage	630 V	1000 V	1000 V	Rated current	20 A	20 A	5 A
Rated impulse withstand voltage	6 kV	6 kV	6 kV				
Rated current	32 A	32 A	32 A				

Approvals per	CSA		
Use group	B	C	D
Rated voltage	300 V	300 V	600 V
Rated current	20 A	20 A	5 A

## Connection Data

Clamping units	6	<b>Connection 1</b>	
Total number of potentials	6	Connection technology	Push-in CAGE CLAMP®
Number of connection types	1	Actuation type	Lever
Number of levels	1	Solid conductor	0.2 ... 4 mm <sup>2</sup> / 24 ... 12 AWG
		Fine-stranded conductor	0.2 ... 4 mm <sup>2</sup> / 24 ... 12 AWG
		Fine-stranded conductor; with insulated ferrule	0.25 ... 2.5 mm <sup>2</sup>
		Fine-stranded conductor; with uninsulated ferrule	0.25 ... 2.5 mm <sup>2</sup>
		Fine-stranded conductor; with twin ferrule	0.25 ... 1.5 mm <sup>2</sup>
		Strip length	9 ... 11 mm / 0.35 ... 0.43 inches
		Conductor connection direction to PCB	90°
		Pole number	6

## Physical data

Pin spacing	7.5 mm / 0.295 inches
Width	44.9 mm / 1.768 inches
Height	25.3 mm / 0.996 inches
Height from the surface	21.3 mm / 0.839 inches
Depth	16.7 mm / 0.657 inches
Solder pin length	4 mm
Solder pin dimensions	0.8 x 1 mm
Drilled hole diameter	1.3 <sup>(+0.1)</sup> mm

### PCB contact

PCB contact	THT
Solder pin arrangement	over the entire terminal strip (in-line)
Number of solder pins per potential	2

### Material data

Note (material data)	<a href="#">Information on material specifications can be found here</a>
Color	gray
Material group	I
Insulation material (main housing)	Polyamide (PA66)
Flammability class per UL94	V0
Clamping spring material	Chrome-nickel spring steel (CrNi)
Contact material	Electrolytic copper (E <sub>Cu</sub> )
Contact Plating	Tin
Fire load	0.196 MJ
Actuator color	orange
Weight	11.9 g

### Environmental requirements

Limit temperature range	-60 ... +105 °C
Processing temperature	-35 ... +60 °C
Continuous operating temperature	-60 ... +105 °C

### Commercial data

PU (SPU)	40 pcs
Packaging type	Box
Country of origin	PL
GTIN	4066966388916
Customs tariff number	85369010000

### Product Classification

UNSPSC	39121409
eCl@ss 10.0	27-44-04-01
eCl@ss 9.0	27-44-04-01
ETIM 9.0	EC002643
ETIM 10.0	EC002643
ECCN	NO US CLASSIFICATION

### Environmental Product Compliance

RoHS Compliance Status	Compliant, No Exemption
------------------------	-------------------------

**Approvals / Certificates**

**General approvals**



Approval	Standard	Certificate Name
CB DEKRA Certification B.V.	IEC 60947-7-4	NL-61583
KEMA/KEUR DEKRA Certification B.V.	EN 60947-7-4	71-100535
UL Underwriters Laboratories Inc.	UL 1059	E45172

**Downloads**

**Environmental Product Compliance**

Compliance Search
Environmental Product Compliance 2604-3306

**Documentation**

Additional Information			
Technical Section	03.04.2019	pdf 2027.26 KB	

**CAD/CAE-Data**

CAD data
2D/3D Models 2604-3306

CAE data
ZUKEN Portal 2604-3306

PCB Design
Symbol and Footprint via SamacSys 2604-3306
Symbol and Footprint via Ultra Librarian 2604-3306

## 1 Compatible Products

### 1.1 Optional Accessories

#### 1.1.1 Ferrule

##### 1.1.1.1 Ferrule



**Item No.: 216-241**

Ferrule; Sleeve for 0.5 mm<sup>2</sup> / 20 AWG; insulated; electro-tin plated; electrolytic copper; gastight crimped; acc. to DIN 46228, Part 4/09.90; white

**Item No.: 216-242**

Ferrule; Sleeve for 0.75 mm<sup>2</sup> / 18 AWG; insulated; electro-tin plated; electrolytic copper; gastight crimped; acc. to DIN 46228, Part 4/09.90; gray

**Item No.: 216-243**

Ferrule; Sleeve for 1 mm<sup>2</sup> / AWG 18; insulated; electro-tin plated; electrolytic copper; gastight crimped; acc. to DIN 46228, Part 4/09.90; red

**Item No.: 216-244**

Ferrule; Sleeve for 1.5 mm<sup>2</sup> / AWG 16; insulated; electro-tin plated; electrolytic copper; gastight crimped; acc. to DIN 46228, Part 4/09.90; black



**Item No.: 216-246**

Ferrule; Sleeve for 2.5 mm<sup>2</sup> / AWG 14; insulated; electro-tin plated; electrolytic copper; gastight crimped; acc. to DIN 46228, Part 4/09.90; blue

**Item No.: 216-106**

Ferrule; Sleeve for 2.5 mm<sup>2</sup> / AWG 14; uninsulated; electro-tin plated; silver-colored

## Installation Notes

### Conductor termination



Insert fine-stranded conductors – and remove all conductors – via operating tool.

### Conductor termination



Insert solid conductors via push-in termination.