

1.0MHZ BOOST CONVERTER WITH 38V INTERNAL MOSFET SWITCH

December 2025

GENERAL DESCRIPTION

IS31BL3508A is a boost converter featuring an integrated MOSFET switch designed for driving series strings of LED or other device. Input operating voltage range is 2.7V~5.5V. The device regulates the LED load current is set using an external, low value sensing resistor. The device adjusts the PWM duty cycle of the switch to maintain the voltage at the FB pin at a value of 0.3V.

The IS31BL3508A operates at a constant switching frequency of 1.0MHz to allow for small component size. IS31BL3508A features an over voltage shutdown pin which prevents the output voltage from exceeding 38V (Typ.) in the case of an open circuit condition.

The device is offered in TSOT-23-6 and SOT-23-6 packages and a temperature rating from -40°C ~ +85°C.

FEATURES

- Supply voltage: 2.7V~5.5V
- Built-in soft start
- Drive series strings of 10 LEDs or 3×8 LEDs
- PWM or DC voltage dimming
- Frequency of PWM is 500Hz ~ 500kHz
- 1.0MHz high speed switching frequency
- 0.3V feedback voltage
- Integrated high power MOSFET
- Over voltage protection
- -40°C ~ +85°C working temperature range
- TSOT-23-6 and SOT-23-6 packages
- RoHS & Halogen-Free Compliance
- TSCA Compliance

APPLICATIONS

- Small LCD Backlights
- Notebook PC
- GPS

TYPICAL APPLICATION CIRCUIT

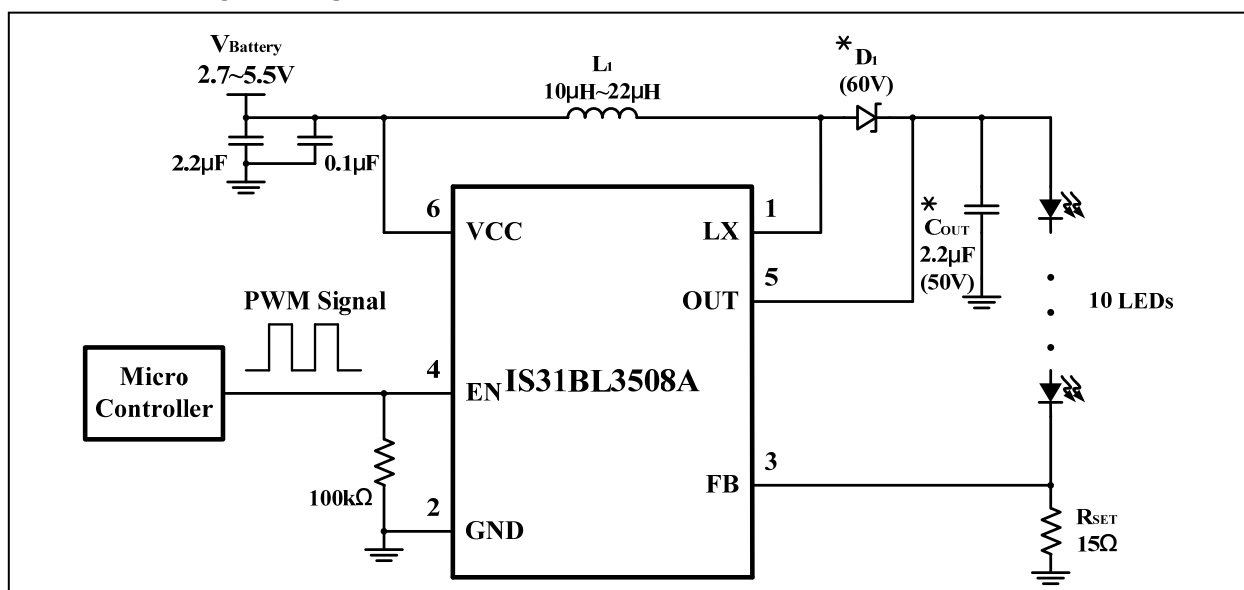

Figure 1 Constant Current White LED Driver Using PWM At The EN Pin To Control Intensity

Note 1: C_{OUT} must be rated for 50V. Smaller values of output capacitance will cause the LED current ripple to increase.

Note 2: The resistor R_{SET} should be placed as close as possible to the FB pin to prevent the EMI.

Note 3: D_1 must choose 60V and peak current is determined by the load. Please refer to Page 9 for detail information.

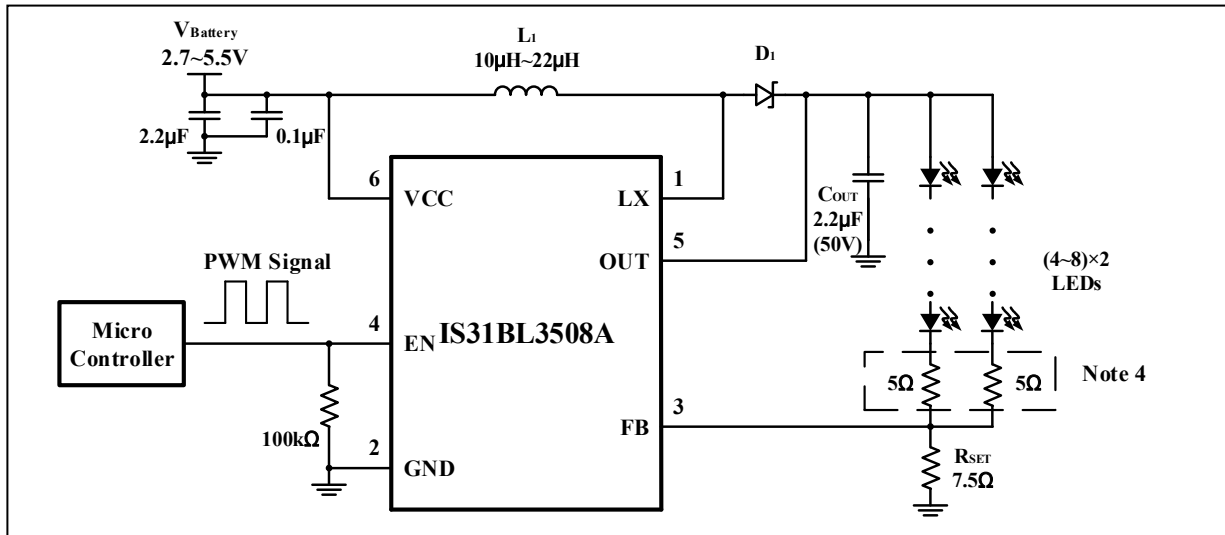

Figure 2 Constant Current White LED Driver Using PWM At The EN Pin To Control Intensity (4~8) x 2 LEDs

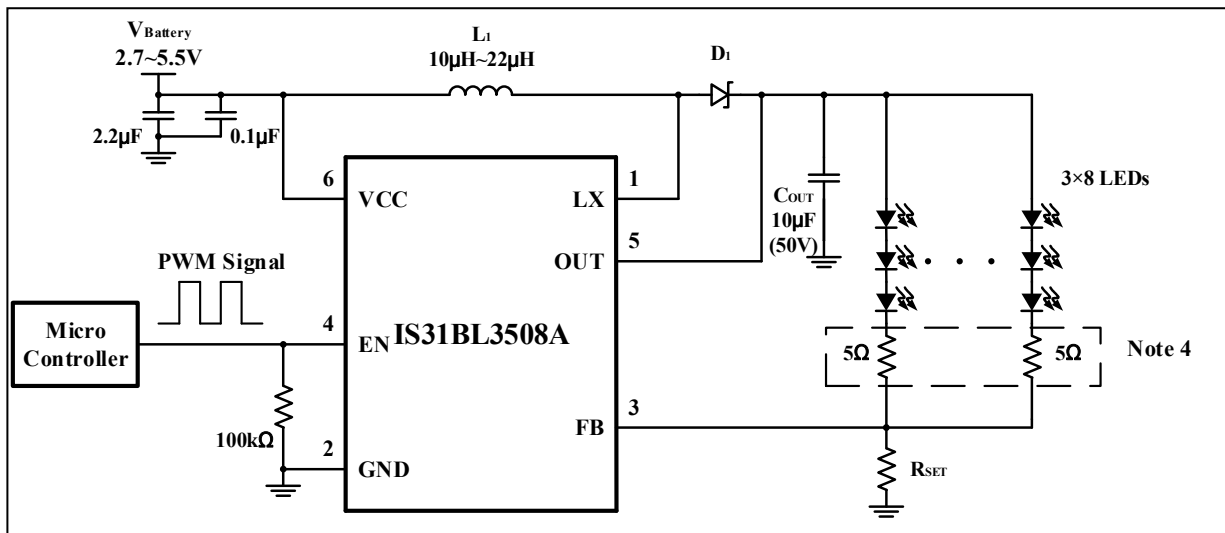

Figure 3 Constant Current White LED Driver Using PWM At The EN Pin To Control Intensity 3 x 8 LEDs

Note 4: When using multiple LED strings in parallel, it is recommended to add a small ballast resistor (typically 1Ω to 5Ω) in series with each string to improve current sharing and reduce the impact of LED forward-voltage and temperature variations. Select the resistor so that its voltage drop at typical LED current is approximately 50mV to 200mV.

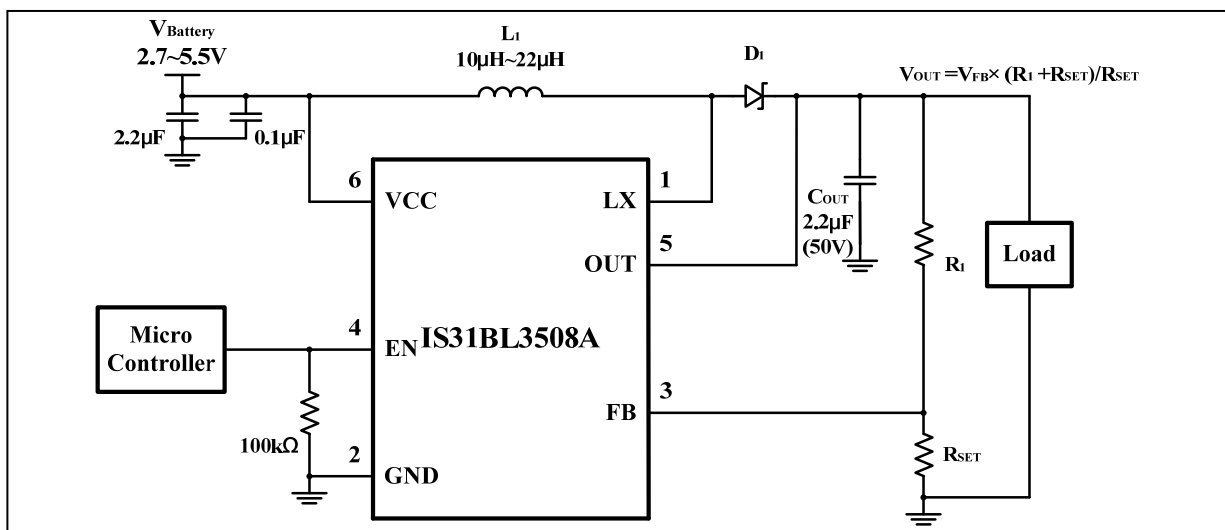

Figure 4 Constant Output Voltage For General Purpose Use

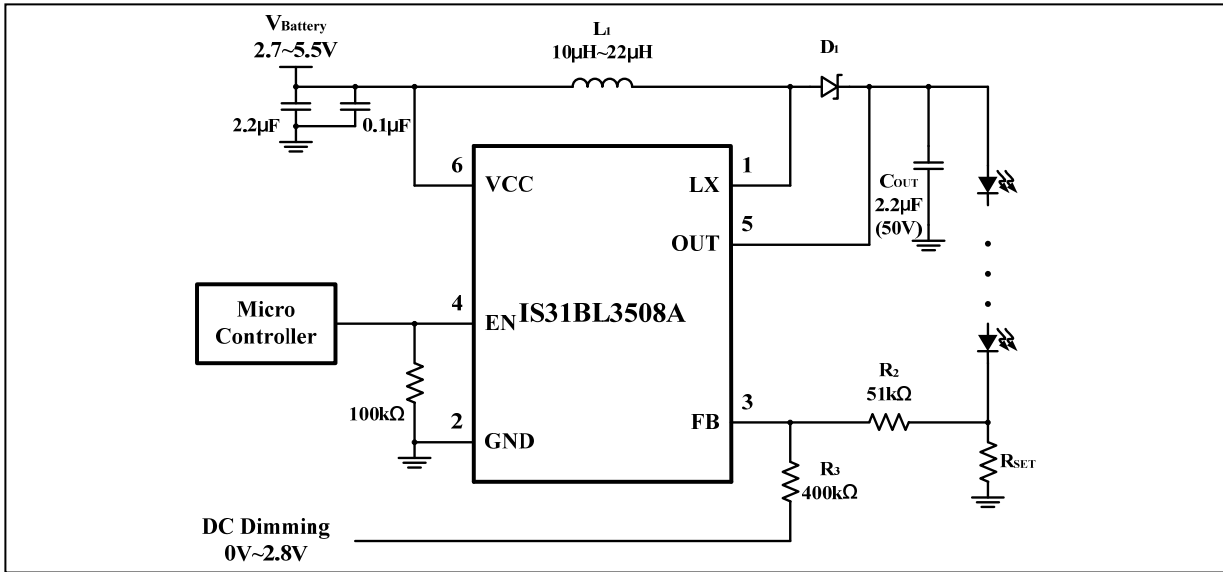

Figure 5 Constant Output Current With DC Dimming Input

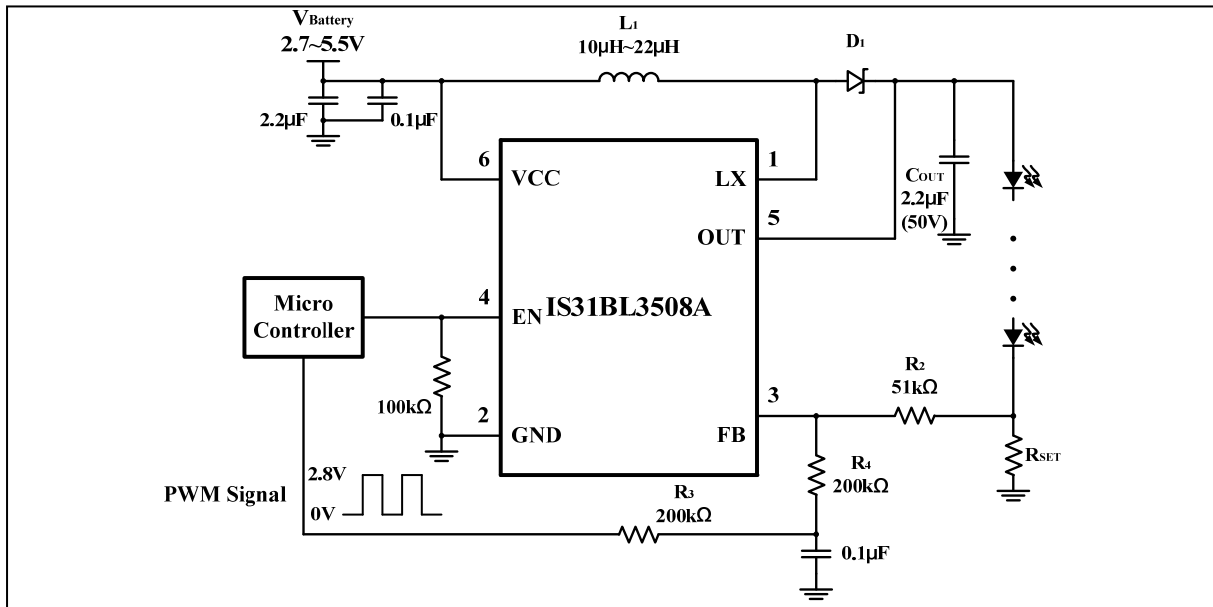
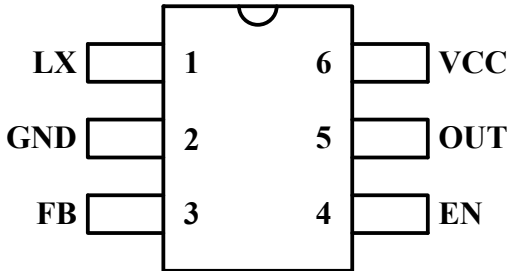

Figure 6 Constant Output Current With PWM Dimming Control

IS31BL3508A

PIN CONFIGURATION

Package	Pin Configurations (Top View)
TSOT-23-6 SOT-23-6	

PIN DESCRIPTION

No.	Pin	Description
1	LX	Switch input, connect to the inductor.
2	GND	Ground.
3	FB	Feedback input pin.
4	EN	Device enable pin, active high.
5	OUT	Output voltage sense pin for over voltage protection.
6	VCC	Supply voltage input pin.

IS31BL3508A



ORDERING INFORMATION

Industrial Range: -40°C to +85°C

Order Part No.	Package	QTY/Reel
IS31BL3508A-TTLS2-TR	TSOT-23-6, Lead-free	3000
IS31BL3508A-STLS2-TR	SOT-23-6, Lead-free	

Copyright © 2025 Lumissil Microsystems. All rights reserved. Lumissil Microsystems reserves the right to make changes to this specification and its products at any time without notice. Lumissil Microsystems assumes no liability arising out of the application or use of any information, products or services described herein. Customers are advised to obtain the latest version of this device specification before relying on any published information and before placing orders for products.

Lumissil Microsystems does not recommend the use of any of its products in life support applications where the failure or malfunction of the product can reasonably be expected to cause failure of the life support system or to significantly affect its safety or effectiveness. Products are not authorized for use in such applications unless Lumissil Microsystems receives written assurance to its satisfaction, that:

- a.) the risk of injury or damage has been minimized;
- b.) the user assume all such risks; and
- c.) potential liability of Lumissil Microsystems is adequately protected under the circumstances

Lumissil Microsystems – www.lumissil.com

Rev. C, 12/23/2025

ABSOLUTE MAXIMUM RATINGS

Supply voltage, V_{CC}	-0.3V ~ +6.0V
LX pin voltage	-0.3V ~ +40V
Voltage at any input pin	-0.3V ~ +6.0V
Maximum junction temperature, T_{JMAX}	+150°C
Storage temperature range, T_{STG}	-65°C ~ +150°C
Operating temperature range, T_A	-40°C ~ +85°C

Note 5: Stresses beyond those listed under “Absolute Maximum Ratings” may cause permanent damage to the device. These are stress ratings only and functional operation of the device at these or any other condition beyond those indicated in the operational sections of the specifications is not implied. Exposure to absolute maximum rating conditions for extended periods may affect device reliability.

ELECTRICAL CHARACTERISTICS

Test conditions are $T_A = 25^\circ\text{C}$, $V_{CC} = 3.6\text{V}$, unless otherwise noted.

Symbol	Parameter	Condition	Min	Typ	Max	Unit
V_{CC}	Supply voltage		2.7		5.5	V
I_{CC}	Quiescent current	Switching		1.1	1.3	mA
I_{SD}	Shutdown current	$V_{EN} = 0\text{V}$		2	2.5	μA
V_{EN_ON}	EN input logic high	V_{EN} rising	1.4			V
V_{EN_OFF}	EN input logic low	V_{EN} falling			0.4	V
f_{OSC}	Operating frequency			1		MHz
D_{MAX}	Maximum duty cycle		91.5	92.7	95.5	%
R_{DS_ON}	LX switch on resistance			0.7		Ω
I_{SW_LK}	LS switch leakage current	$V_{SW} = 38\text{V}$			1	μA
I_{SW_LIMIT}	Switch over current limit	Duty = 90%	1.2	1.6	1.8	A
V_{OVP}	OUT over voltage protection		36	38	40	V
V_{FB}	Feedback voltage		285	300	315	mV
T_{ST}	Over temperature protection	(Note 6)		160		$^\circ\text{C}$

Note 6: Guaranteed by design.

TYPICAL PERFORMANCE CHARACTERISTIC

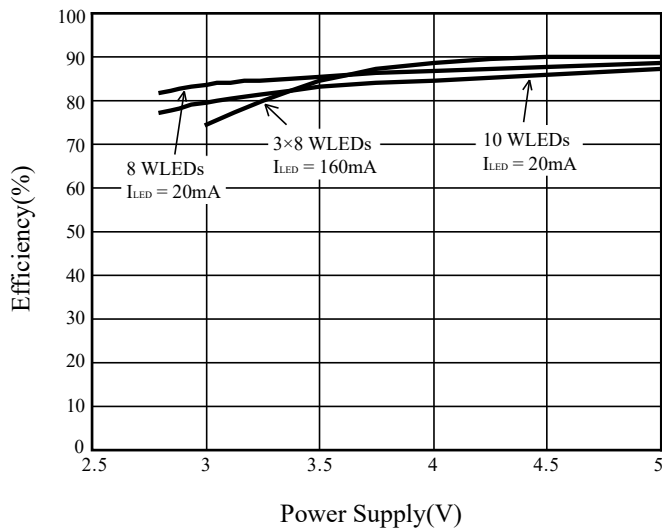

Figure 7 Efficiency vs. V_{CC}

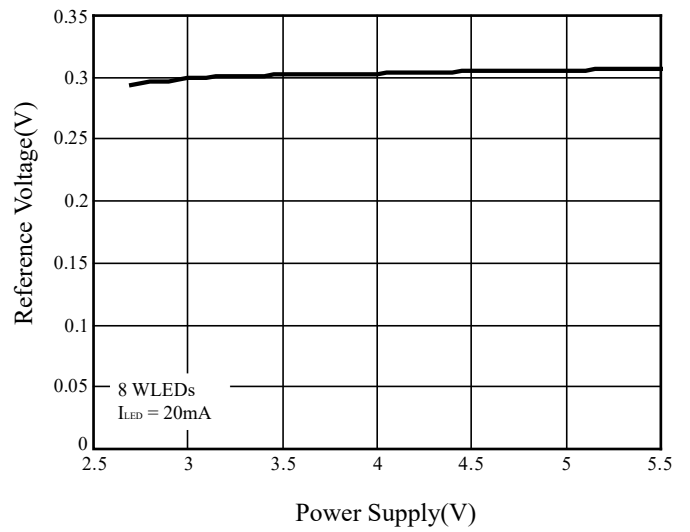

Figure 8 V_{FB} vs. V_{CC}

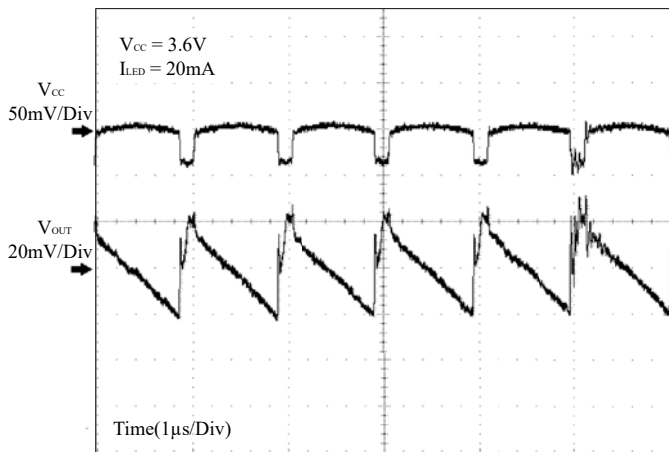

Figure 9 Ripple Voltage

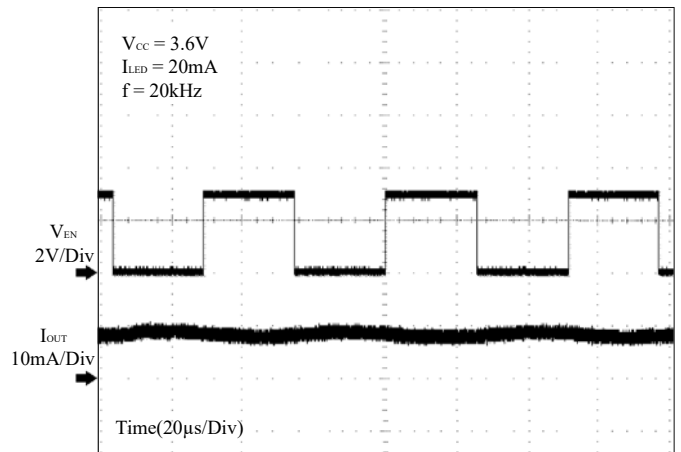

Figure 10 PWM Dimming from EN

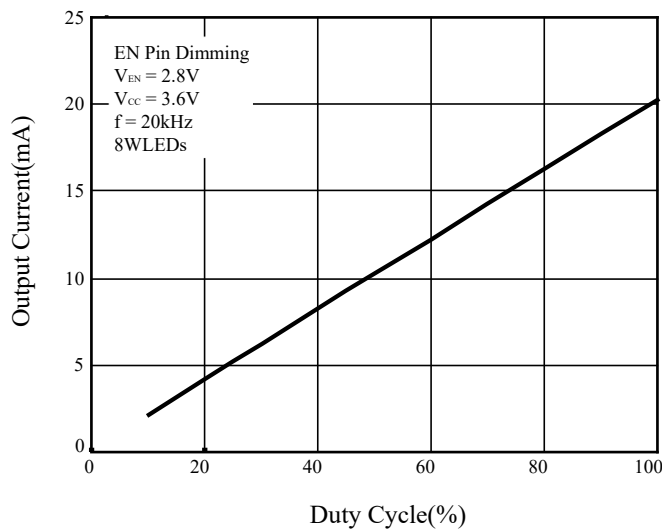

Figure 11 Enable Pin Dimming

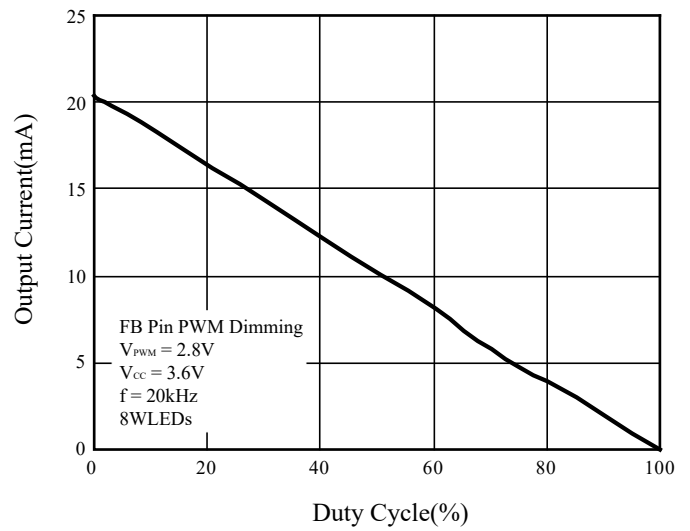
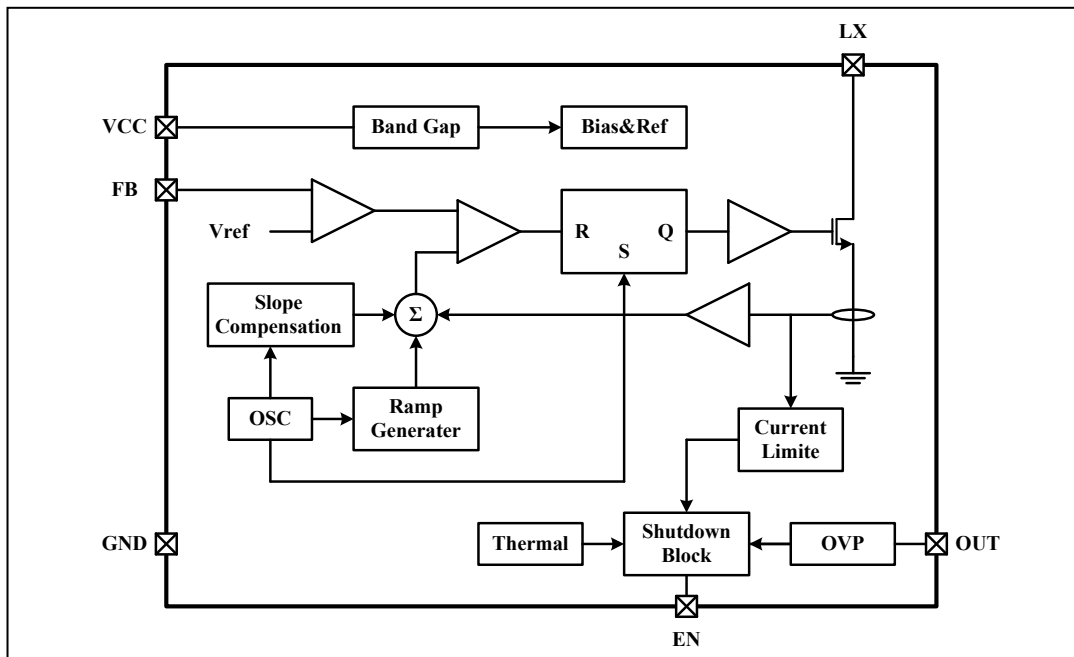

Figure 12 FB pin PWM Dimming

IS31BL3508A

FUNCTIONAL BLOCK DIAGRAM



APPLICATION INFORMATION

INPUT AND OUTPUT CAPACITOR

A 2.2 μ F input capacitor is used to reduce input ripple and noise, where the input ripple amplitude is inversely proportional to the value of the input capacitance. The input and output capacitors should be placed as close to the device as possible, so as to reduce the effect of voltage ripple. The value of the output capacitor is dependent upon the output ripple. A 2.2 μ F or 10 μ F ceramic capacitor with a 50V rating is sufficient for the majority of applications.

INDUCTOR VALUE

The choice of the inductor value will affect the performance of the device. Large value inductors will reduce the current ripple in the inductor, thus reducing output voltage ripple. However large value inductors of the same current rating, typically also have larger DC resistance, thus reducing the system efficiency. For example in Figure 1, the loads are 10 WLEDs and output current is 20mA. The maximum input current can reach 600mA. For this application a 10 μ H 700mA inductor is sufficient.

DIODE

The diode, D₁, should use schottky diode to optimize the efficiency of system. The rated current and peak current of D₁ should be above output current and peak current of L₁. And the recurrent peak reverse voltage of D₁ should be above OVP voltage. A 1A 60V schottky diode is recommended.

LED CURRENT SETPOINT

When the IS31BL3508A is used for LED driving applications (Figure 1), the LED current flows through the external feedback resistor R_{SET} to regulate the LED current. The internal feedback regulation point is 0.3V. The maximum LED current may be calculated by the following Equation (1).

$$I_{MAX} = V_{FB} / R_{SET} \quad (1)$$

For accurate LED current, resistors should be 1% or better tolerance.

Table 1 Current Setting Resistor (1% Values)

R1(Ω) 1% Values	IMAX Current (mA)
300.0	1
60.0	5
30.0	10
20.0	15
15.0	20
10.0	30
7.5	40
3.0	100

LED INTENSITY CONTROL

EN PIN DIMMING

The EN pin of the IS31BL3508A can accept a PWM signal to implement LED dimming (Figure 1). LED current may be computed using the following Equation (2).

$$I_{LED} = I_{MAX} \cdot D_{PWM} \quad (2)$$

I_{MAX} is computed using equation (1). Recommended PWM frequency is in the range of 500Hz ~ 500kHz. So as to guarantee a reasonably good dimming effect, the minimum duty cycle should be about 10%.

Driving the EN pin with a PWM signal can effectively adjust the LED intensity. The PWM signal voltage levels must meet the EN pin input voltage levels, V_{EN_ON} and V_{EN_OFF}.

IS31BL3508A can also use a DC voltage or PWM signal to directly control the LED current, and thus provide fine adjustment for the LED intensity.

FB PIN DC VOLTAGE DIMMING

The schematic of Figure 5 shows an example of using a DC input voltage at the FB pin to implement LED dimming. When the DC input voltage increases, the current through R₂ and R₃ increases producing an offset voltage across R₂, thereby causing the LED current to be reduced. The LED current may be computed using the following Equation (3). V_{FB} is 0.3V (Typ.).

$$I_{LED} = \frac{V_{FB} - \frac{R_2 \times (V_{DC} - V_{FB})}{R_3}}{R_{SET}} \quad (3)$$

When the DC voltage range is 0V~1.8V, a good value for R₂ is 75k Ω , and for R₃ is 360k Ω .

FB PIN PWM DIMMING

A PWM signal connected to the FB pin can also be used to directly control the LED current (Figure 6). A low pass filter converts the PWM duty cycle to a DC level, which is in turn summed together with the feedback voltage of RSET to effectively reduce the LED current proportionally. Due to the filtering of the PWM signal, the frequency of the PWM signal can have an affect on the output voltage ripple. For a PWM signal input signal of 2.8V, the recommended frequency is greater than 2kHz. Using a fixed frequency PWM signal and adjusting the PWM duty cycle effectively adjusts the LED intensity. LED current may be computed using the following Equation (4). V_{FB} is 0.3V (Typ.).

$$I_{LED} = \frac{V_{FB} - \frac{R_2 \times (V_{PWM} \times Duty - V_{FB})}{R_4 + R_3}}{R_{SET}} \quad (4)$$

For a PWM signal range of 0V~1.8V, a suitable value for R₂ is 75kΩ, R₃ is 150kΩ, R₄ is 200kΩ.

SETTING THE OUTPUT VOLTAGE

The IS31BL3508A can be configured to provide a constant output voltage (Figure 4). The output voltage level can be computed using the following Equation (5). The device internal V_{FB} is 0.3V (typ).

$$V_{OUT} = V_{FB} \times (R_1 + R_{SET}) / R_{SET} \quad (5)$$

OVERVOLTAGE THRESHOLD

Device open circuit protection is realized using the overvoltage protection function (OVP). If the output voltage surpasses the overvoltage threshold, the overvoltage protection circuit is activated and the device will stop working.

CLASSIFICATION REFLOW PROFILES

Profile Feature	Pb-Free Assembly
Preheat & Soak Temperature min (T _{smin}) Temperature max (T _{smax}) Time (T _{smin} to T _{smax}) (t _s)	150°C 200°C 60-120 seconds
Average ramp-up rate (T _{smax} to T _p)	3°C/second max.
Liquidous temperature (T _L) Time at liquidous (t _L)	217°C 60-150 seconds
Peak package body temperature (T _p)*	Max 260°C
Time (t _p)** within 5°C of the specified classification temperature (T _c)	Max 30 seconds
Average ramp-down rate (T _p to T _{smax})	6°C/second max.
Time 25°C to peak temperature	8 minutes max.

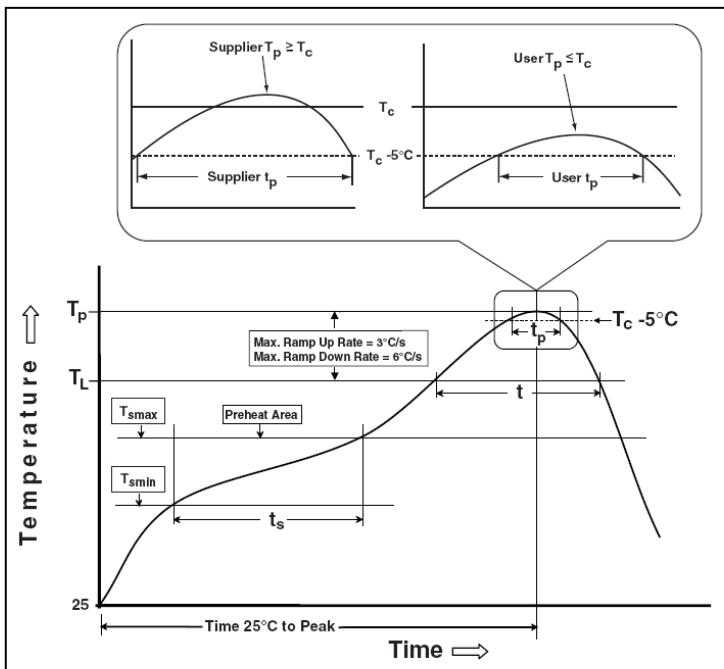
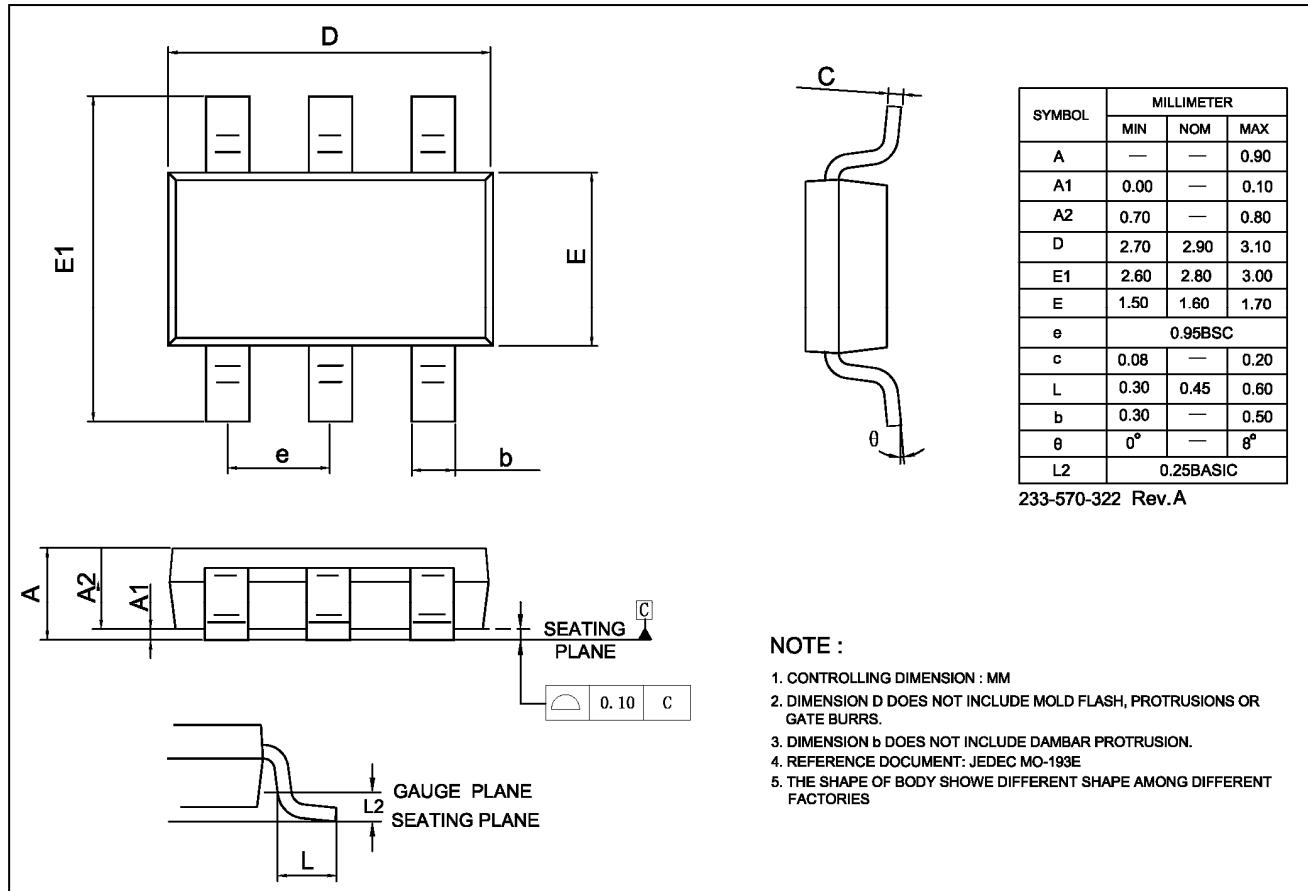

Figure 13 Classification Profile

IS31BL3508A

PACKAGE OUTLINE DRAWING

TSOT-23-6



IS31BL3508A

SOT-23-6

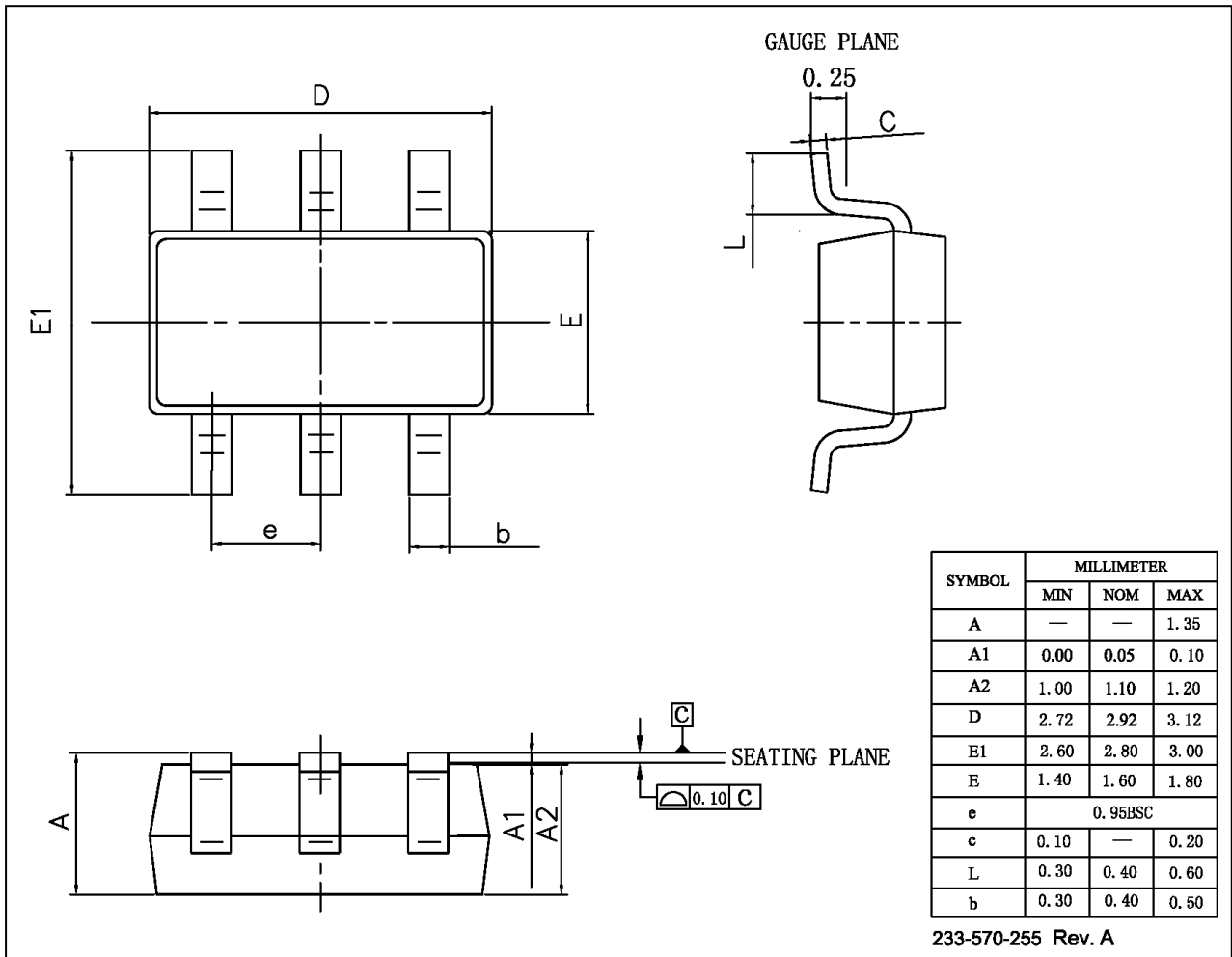

RECOMMENDED LAND PATTERN

TSOT-23-6

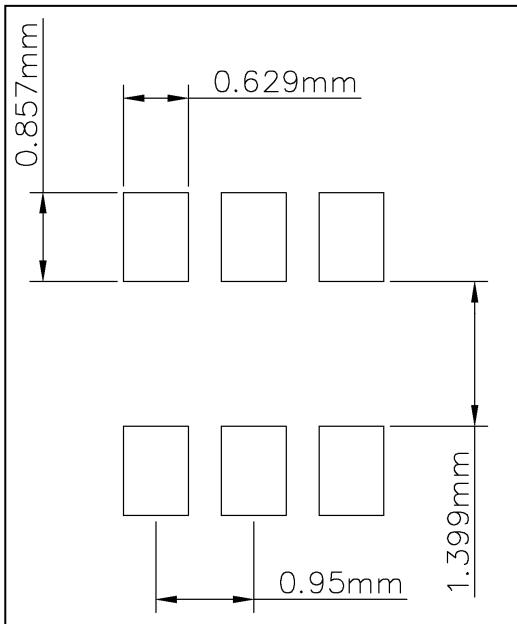

SOT-23-6

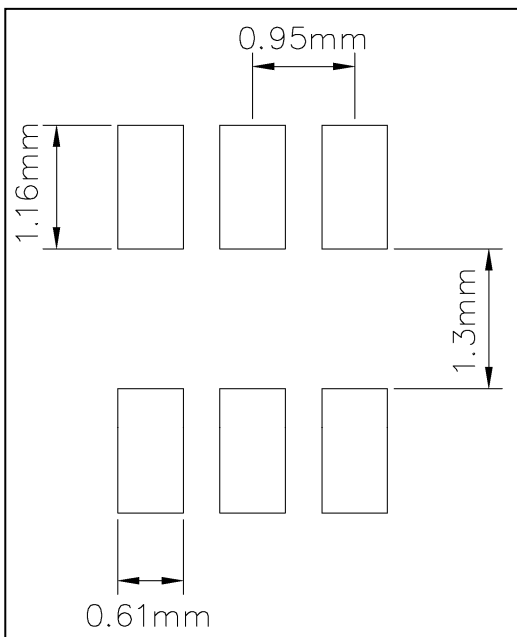

Note:

1. Land pattern complies to IPC-7351.
2. All dimensions in MM.
3. This document (including dimensions, notes & specs) is a recommendation based on typical circuit board manufacturing parameters. Since land pattern design depends on many factors unknown (eg. user's board manufacturing specs), user must determine suitability for use.

REVISION HISTORY

Revision	Detail Information	Date
A	Initial release	2013.05.10
B	1.Update to new Lumissil logo 2.Update POD and add LP, RoHS	2024.04.11
C	1.Update Figure 2/3 and add Note 4 2.Add the Table 1 Current Setting Resister	2025.12.23