

6

5

4

3

2

1

D

C

B

A

D

C

B

A

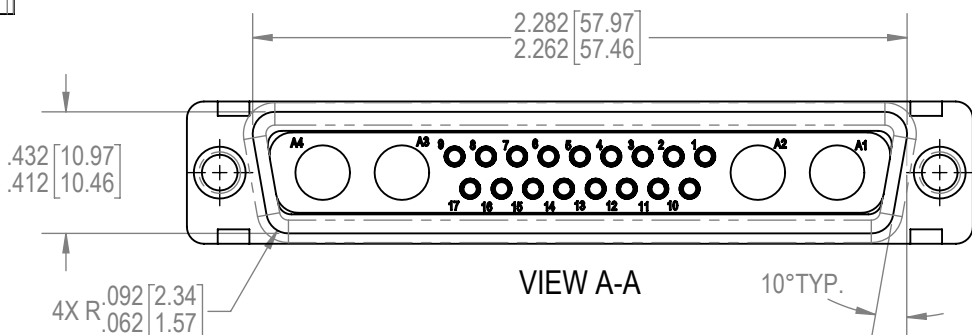
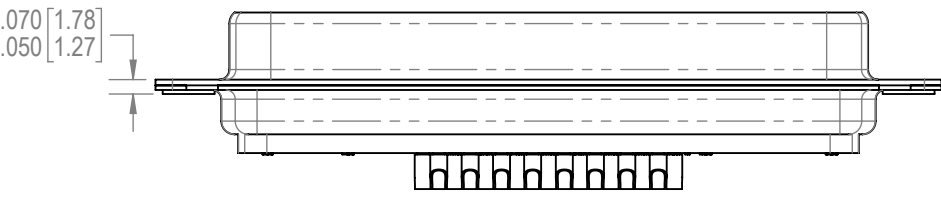
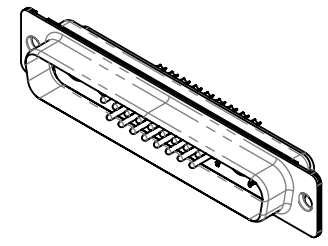
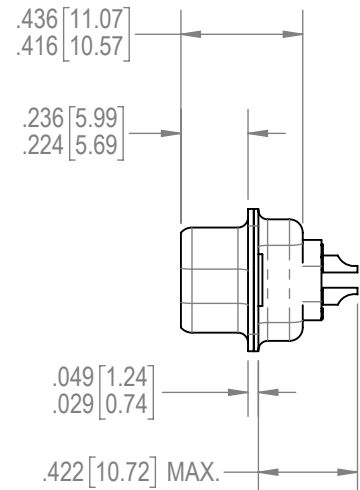
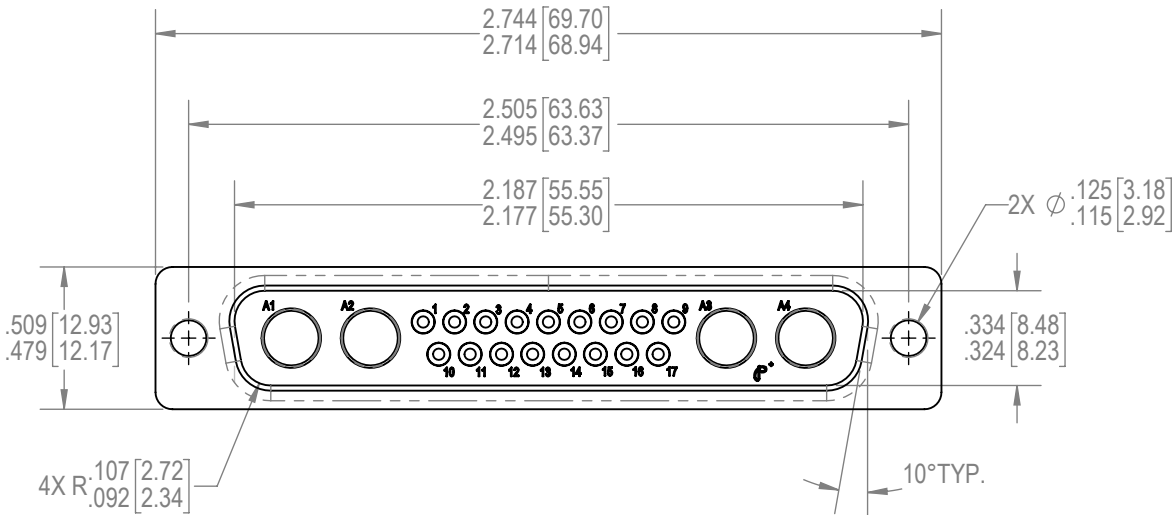

- NOTES:**
1. THE REQUIREMENTS FOR THE PRODUCT HERE IN SHALL CONSIST OF DSCC.
 2. IN THE EVENT OF A CONFLICT BETWEEN THIS DOCUMENT AND DSCC, DSCC SHALL TAKE PRECEDENCE.

BY DW	CHK EB	3RD ANGLE 	POSITRONIC BELIEVES THE DATA ON THE DRAWING TO BE RELIABLE. THE USER EMPLOYS SUCH INFORMATION AT HIS OWN DISCRETION AND RISK. POSITRONIC ASSUMES NO RESPONSIBILITY FOR RESULTS OBTAINED OR DAMAGES INCURRED FROM USE OF SUCH INFORMATION IN WHOLE OR IN PART.	 Positronic CONNECTPOSITRONIC.COM
APR SSC	RELEASED DATE: 2022-04-04	SCALE NTS		
TOLERANCES ±0.010 INCHES [0.25 mm]		PART NUMBER 85048GBEPR	SERIES M24308	
DIMENSIONS ARE IN INCHES. (MILLIMETER EQUIVELANTS GIVEN FOR REFERENCE ONLY)		TITLE 85048GBEPR		
CREATED ON: 2022-04-04		SHEET SHEET 1 OF 1	REV B	

6

5

4

3

2

1