

Color: ■ white

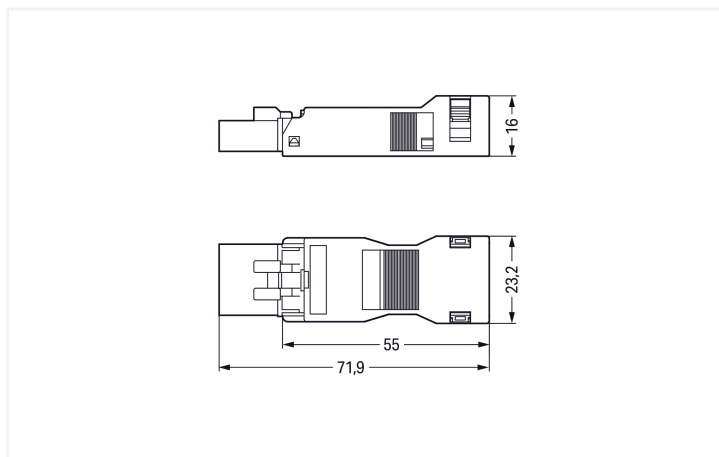

Dimensions in mm

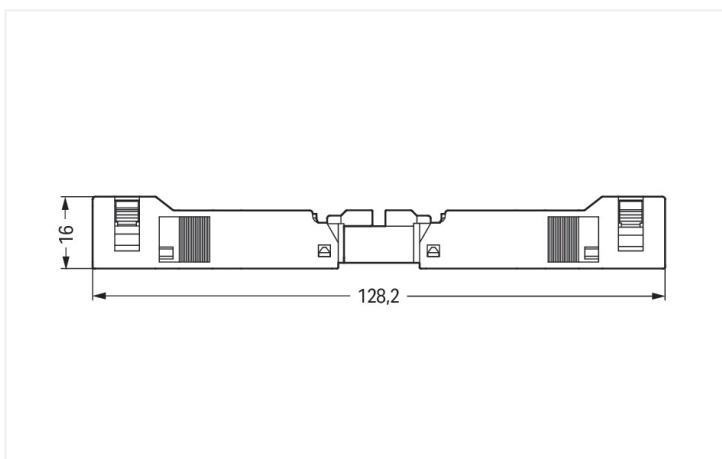

Dimensions in mm
Overall length when mated

Male connector/plug WINSTA® MINI with strain relief

The WINSTA® MINI male connector/plug with protection type IP40 allows installation of solid and fine-stranded conductors. On PCBs, in control cabinets or for connecting lights – pluggable installation connectors from WAGO allow you to make connections according to a huge variety of requirements in

no time flat. For greater protection in electrical installations, the pluggable installation connector is equipped with mechanical protection against mismatching. The pluggable installation connector is protected in accordance with protection type IP40. Users' hands and tools will never come into contact with live elements. Thanks to the color coding and mechanical A coding of WINSTA® MINI pluggable installation connectors, you can clearly distinguish different circuits. Especially where space is tight, our smallest pluggable connection system, WINSTA® MINI, consistently displays its advantageous properties. It saves space, and, thanks to Push-in CAGE CLAMP® spring pressure connection technology, it additionally can be installed quickly, since the installation is low-maintenance and can be performed without screw connections. The strip length is 45 mm.

Lower costs through fast commissioning and elimination of service expenses – solutions from WINSTA® MINI

WINSTA® is the pluggable connection system that is perfectly tailored to the strict requirements of electrical installation. It allows fast, secure and, above all, error-free installation of components and cables. Take advantage of the pluggable version of our maintenance-free spring pressure connection technology too! Plan your installation with with marking from WAGO.

- protection against mismatching eliminates errors
- compact design for conductors with a cross-section up to 1.5 mm²
- with A coding for use in a large number of general mains applications
- custom-engineered solutions
- convenient installation and commissioning

This item includes:



Item No.: 890-234	1	Item No.: 890-514	1
Plug; 4-pole; Cod. A; 1,50 mm ² ; white		Strain relief housing; 4-pole; with locking clip; for 1 cable; 6.5 ... 10.5 mm; 45 mm; white	

Notes

General safety information	<ol style="list-style-type: none"> 1. Only to be used by a qualified electrician or by a person electrically instructed for the task (EIP per DIN VDE 0105-100). 2. Do not install while energized or under load. 3. Use only for its intended purpose. 4. Observe applicable national regulations, standards and directives. 5. Observe the technical specifications of the products. 6. Ensure correct polarity assignment. 7. Do not use damaged or contaminated components. 8. Observe conductor types, conductor cross-sections, strip lengths and cable diameters. 9. Insert conductors up to the stop. 10. Use only with locking lever and strain relief. 11. Use original accessories only. <p>To be sold only with installation instructions!</p>
----------------------------	----------------------------------------------------------------------------------------------------------------------------------------------------------------------------------------------------------------------------------------------------------------------------------------------------------------------------------------------------------------------------------------------------------------------------------------------------------------------------------------------------------------------------------------------------------------------------------------------------------------------------------------------------------------------------------------------------------------------------------------------------------------------------------------------------------------------------------------------------------------------------

Electrical data

Ratings per	IEC/EN 60664-1			Approvals per	UL 1977
Overvoltage category	III	III	II	Rated voltage	600 V
Pollution degree	3	2	2	Rated current	12 A
Nominal voltage	400 V	-	-		
Rated impulse withstand voltage	6 kV	-	-		
Rated current	16 A	-	-		

General information

Note on contact resistance	approx. 1 mΩ of contact resistance approx. 0.25 mΩ contact transition plug/ socket
----------------------------	---------------------------------------------------------------------------------------

Connection Data

Clamping units	4
Total number of potentials	4
PE function	Preceding PE contact

Connection 1

Connection technology	Push-in CAGE CLAMP®
Actuation type	Operating tool Push-in
Nominal cross-section	1.5 mm ² / 16 AWG
Solid conductor	0.25 ... 1.5 mm ² / 22 ... 16 AWG
Solid conductor; push-in termination	0.75 ... 1.5 mm ² / 20 ... 16 AWG
Stranded conductor	0.25 ... 1 mm ² / 22 ... 18 AWG
Fine-stranded conductor	0.25 ... 1.5 mm ² / 22 ... 16 AWG
Fine-stranded conductor; with insulated ferrule	0.25 ... 0.75 mm ² / 22 ... 20 AWG
Fine-stranded conductor; with uninsulated ferrule	0.25 ... 0.75 mm ² / 22 ... 20 AWG
Fine-stranded conductor; with ferrule; push-in termination	0.75 mm ² / 20 AWG
Strip length	9 mm / 0.35 inches
Pole number	4
Connectable sheathed cable diameter	6.5 ... 10.5 mm
Conductor entry direction to mating direction	0°
Strip length (outer insulation)	45 mm

Physical data

Pin spacing	4.4 mm / 0.173 inches
Width	23.2 mm / 0.913 inches
Height	16 mm / 0.63 inches
Depth	71.9 mm / 2.831 inches

Mechanical data

Use	General mains applications
Coding	A
Variable coding	No
Marking	1/L' 2/L ⊕ N
Potential marking	1/L' 2/L ⊕ N
Mating force of a plug-in connection	approx. 20 ... 70 N (depending on pole number)
Retention force of a plug-in connection	Locked: > 80 N
Unmating force of a plug-in connection	Unlocked: approx. 20 ... 70 N (depending on pole number)
Number of mating cycles	200, without resistive load
Protection type	IP40

Plug-in connection

Contact type (pluggable connector)	Male connector/plug
Connector (connection type)	for conductor
Mismating protection	Yes
Note on mismating protection	All WINSTA® components are 100% protected against mismating when: a.) plugging different numbers of poles b.) plugging while rotated 180° c.) plugging while laterally staggered d.) plugging one pole
Locking lever	Can be retrofitted
Locking of plug-in connection	Locking lever
Note on locking system	All connectors for mounted installations (snap-in versions for lighting fixtures or devices, all types of PCB and distribution connectors) are factory-equipped with locking levers to ensure plugs and sockets are securely locked. Additional locking levers are only required for flying leads (plug/socket).
Strain relief	Strain relief housing

Material data

Note (material data)	Information on material specifications can be found here
Color	white
Cover color	gray
Material group	I
Insulation material (main housing)	Polyamide (PA66)
Flammability class per UL94	V0
Clamping spring material	Chrome-nickel spring steel (CrNi)
Contact material	Copper or copper alloy; surface-treated
Contact Plating	Tin
Fire load	0.25 MJ
Connector color	white
Strain relief color	white
Weight	10.3 g

Environmental requirements

Processing temperature	-5 ... +40 °C
Continuous operating temperature	-35 ... +85 °C
Note on continuous operating temperature	Insulating parts for temperatures ≤ 105 °C

Commercial data

Product Group	20 (Winsta)
PU (SPU)	50 pcs
Packaging type	Box
Country of origin	DE
GTIN	4045454233020
Customs tariff number	85366990990

Product Classification

UNSPSC	39121402
eCl@ss 10.0	27-44-06-05
eCl@ss 9.0	27-44-06-05
ETIM 9.0	EC002560
ETIM 10.0	EC002560
ECCN	NO US CLASSIFICATION

Environmental Product Compliance

RoHS Compliance Status	Compliant, No Exemption
------------------------	-------------------------

Approvals / Certificates

General approvals



Approval	Standard	Certificate Name
CCA DEKRA Certification B.V.	EN 61535	71-123231
CCA DEKRA Certification B.V.	IEC 61535	NL-85020
cURus Underwriters Laboratories Inc.	UL 1977	E45171

Declarations of conformity and manufacturer's declarations

Approval	Standard	Certificate Name
EU-Declaration of Confor- mity WAGO GmbH & Co. KG	-	-
UK-Declaration of Confor- mity WAGO GmbH & Co. KG	-	-

Approvals for marine applications



Approval	Standard	Certificate Name
ABS American Bureau of Ship- ping	Steel Vessel Rules	24-0095973-PDA
DNV GL Det Norske Veritas, Ger- manischer Lloyd	-	TAE00001Z6
LR Lloyds Register	EN 61535	LR23317167TA
PRS Polski Rejestr Statków	-	TE/1096/880590/23

Downloads

Environmental Product Compliance

Compliance Search
Environmental Product Compliance 890-134

Documentation

Bid Text			
890-134	19.02.2019	xml 3.01 KB	
890-134	08.06.2015	doc 23.50 KB	

CAD/CAE-Data

CAD data
2D/3D Models 890-134

CAE data
WSCAD Universe 890-134
ZUKEN Portal 890-134

1 Compatible Products

1.1 System counterpart

1.1.1 Cable assembly



[Item No.: 891-8994/106-102](#)
pre-assembled connecting cable; Eca;
Socket/open-ended; 4-pole; Cod. A;
H05VV-F 4G 1.5 mm²; 1 m; 1,50 mm²; whi-
te

[Item No.: 891-8994/006-102](#)
pre-assembled interconnecting cable;
Eca; Socket/plug; 4-pole; Cod. A; H05VV-
F 4G 1.5 mm²; 1 m; 1,50 mm²; white

1.1.2 Distribution connector



Item No.: 890-994

h-distribution connector; 4-pole; Cod. A; 1 input; 2 outputs; outputs on one side; 2 locking levers; white



Item No.: 890-995

h-distribution connector; 4-pole; Cod. A; 1 input; 2 outputs; outputs on one side; 3 locking levers; for flying leads; white



Item No.: 890-676

T-distribution connector; 4-pole; Cod. A; 1 input; 2 outputs; 2 locking levers; white



Item No.: 890-677

T-distribution connector; 4-pole; Cod. A; 1 input; 2 outputs; 3 locking levers; for flying leads; white

1.1.3 Female connector/socket



Item No.: 890-724

Snap-in socket; 4-pole; Cod. A; 1,50 mm²; white



Item No.: 890-824/011-000

Socket for PCBs; angled; 4-pole; Cod. A; white



Item No.: 890-824

Socket for PCBs; straight; 4-pole; Cod. A; white



Item No.: 890-224

Socket; 4-pole; Cod. A; 1,50 mm²; white



Item No.: 890-124

Socket; with strain relief housing; 4-pole; Cod. A; 1,50 mm²; white

1.2 Required Accessories

1.2.1 Locking system

1.2.1.1 Locking system



Item No.: 890-111

Locking lever; for flying leads; for tool operation; black



Item No.: 890-131

Locking lever; for flying leads; for tool operation; white



Item No.: 890-101

Locking lever; for manual operation; black



Item No.: 890-121

Locking lever; for manual operation; white

1.3 Optional Accessories

1.3.1 Cover

1.3.1.1 Cover



Item No.: 897-2003

Protective cap; Type2; for sockets and plugs; PVC; red

1.3.2 Installation

1.3.2.1 Mounting accessories



Item No.: 890-310

Mounting carrier; 2- to 5-pole; for flying leads; black



Item No.: 890-311

Mounting carrier; 2- to 5-pole; for flying leads; white

1.3.3 Shield termination

1.3.3.1 Shield termination



Item No.: 890-525

Shield connecting plate; 4-pole; for plugs

1.3.4 Tool

1.3.4.1 Operating tool



Item No.: 890-384

Operating tool; 4-way; green



Item No.: 210-719

Operating tool; Blade: 2.5 x 0.4 mm; with a partially insulated shaft

Installation Notes

Conductor termination



1. Strip length, outer insulation = 30 mm (2-pole), 37 mm (3-pole), 45 mm (4- and 5-pole)
2. Strip length = 9 mm
3. Extended ground conductor = 8 mm

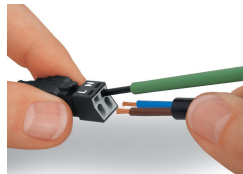

To terminate fine-stranded conductors, open the clamping unit via screwdriver – 2.5 mm blade width – and insert a stripped conductor until it hits the backstop. Terminate solid conductors by simply pushing them in.

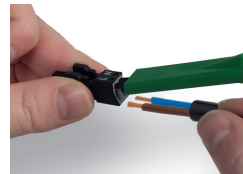

To terminate fine-stranded conductors, open clamping units via operating tool (890-382) and insert stripped conductors until they hit backstop. Terminate solid conductors by simply pushing them in.

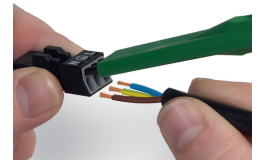

To terminate fine-stranded conductors, open clamping units via operating tool (890-383) and insert stripped conductors until they hit backstop. Terminate solid conductors by simply pushing them in.

Installation

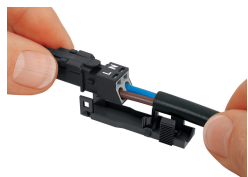

Latch the wired connector into the base of the strain relief housing.



Push down strain relief clamp by hand.



Push down strain relief clamp with 2.5 mm screwdriver alternately on both sides.

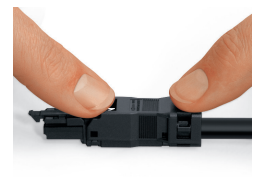

Latch the top of the strain relief housing.



The printed marking of the connector is clearly visible in the openings of the strain relief housing.

Shield termination

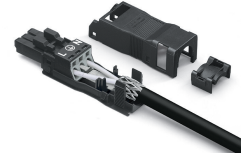

Connector with shield termination

Apply the shield to the sheathed cable.

Strip length, outer insulation = 30 mm
Shield length = 8 mm

Push the shield connecting plate into the connector until fully inserted.

First insert the wired connector into strain relief housing, then snap clamp and cover.