

PanelView Standard Operator Terminals



User Manual

**(Catalog Numbers PV300 Micro, PV300,
PV550, PV600, PV900, PV1000, PV1400)**

ALLEN-BRADLEY • ROCKWELL SOFTWARE **Rockwell
Automation**

Important User Information

Solid state equipment has operational characteristics differing from those of electromechanical equipment. Safety Guidelines for the Application, Installation and Maintenance of Solid State Controls (publication SGI-1.1 available from your local Rockwell Automation sales office or online at <http://literature.rockwellautomation.com>) describes some important differences between solid state equipment and hard-wired electromechanical devices. Because of this difference, and also because of the wide variety of uses for solid state equipment, all persons responsible for applying this equipment must satisfy themselves that each intended application of this equipment is acceptable.





In no event will Rockwell Automation, Inc. be responsible or liable for indirect or consequential damages resulting from the use or application of this equipment.

The examples and diagrams in this manual are included solely for illustrative purposes. Because of the many variables and requirements associated with any particular installation, Rockwell Automation, Inc. cannot assume responsibility or liability for actual use based on the examples and diagrams.

No patent liability is assumed by Rockwell Automation, Inc. with respect to use of information, circuits, equipment, or software described in this manual.

Reproduction of the contents of this manual, in whole or in part, without written permission of Rockwell Automation, Inc., is prohibited.

Throughout this manual, when necessary, we use notes to make you aware of safety considerations.

WARNING 	Identifies information about practices or circumstances that can cause an explosion in a hazardous environment, which may lead to personal injury or death, property damage, or economic loss.
IMPORTANT	Identifies information that is critical for successful application and understanding of the product.
ATTENTION 	Identifies information about practices or circumstances that can lead to personal injury or death, property damage, or economic loss. Attentions help you identify a hazard, avoid a hazard, and recognize the consequence
SHOCK HAZARD 	Labels may be on or inside the equipment, for example, a drive or motor, to alert people that dangerous voltage may be present.
BURN HAZARD 	Labels may be on or inside the equipment, for example, a drive or motor, to alert people that surfaces may reach dangerous temperatures.

Allen-Bradley, Rockwell Automation, and TechConnect are trademarks of Rockwell Automation, Inc.

Trademarks not belonging to Rockwell Automation are property of their respective companies.

Summary of Changes

The information below summarizes the changes to this manual since the last publication.

To help you find new and updated information in this release of the manual, we have included change bars as shown to the right of this paragraph.

Topic	Page
Updated list of supported memory cards.	105
Added information on the proper placement of the sealing gasket.	136 143 150 158 167 173
Added information on airborne contaminants for the PanelView 300 terminal.	235
Added EU Battery Directive to the list of agency certifications.	248
Added information on battery replacement and disposal.	271

Preface	Objectives.	15
	Intended Audience	15
	Conventions	15
	Terminology	15
	Installing PanelView Terminals	15
	European Union Directive Compliance	15
	Additional Resources.	16
	Technical Support.	16
	Chapter 1	
Terminal Overview	Chapter Objectives	17
	Intended Uses.	17
	Terminal Types.	17
	Color and Grayscale Terminals.	18
	PanelView 300 Monochrome Terminals	18
	PanelView 300 Micro Monochrome Terminals.	18
	PanelView 550 Monochrome Terminals	19
	PanelView 600 Color Terminals	20
	PanelView 900 Monochrome Terminals	21
	PanelView 900 Color Terminals	22
	PanelView 1000 Color Terminals	23
	PanelView 1000 Grayscale Terminals	24
	PanelView 1400 Color Terminals	25
	PanelView 300 Micro Terminal Features.	26
	PanelView 300 Micro Terminal Features (front).	26
	PanelView 300 Micro Terminal Features (back).	26
	PanelView 300 Terminal Features	27
	PanelView 300 Terminal Features (front).	27
	PanelView 300 Terminal Features (back).	28
	PanelView 550 Terminal Features	29
	PanelView 550 Terminal Features (front).	29
	PanelView 550 Keypad or Keypad and Touch Screen Terminals (back)	30
	PanelView 550 Touch Screen Terminal Features (back)	32
	PanelView 600 Terminal Features	34
	PanelView 600 Terminal Features (front).	34
	PanelView 600 Keypad or Keypad & Touch Screen Terminal (back).	36
	PanelView 600 Touch Screen Terminal Features (back)	38
	PanelView 900/1000 Terminal Features	40
	PanelView 900/1000 Terminal Features (front)	40
	PanelView 900/1000 Terminal Features (back)	42
	PanelView 1400 Terminal Features.	44
	PanelView 1400 Terminal Features (front).	44
	PanelView 1400 Terminal Features (back and sides)	46

Applications	48
Touch Screen Operation	49
Keypad Operation	49
Configuration Mode Menu	50
Terminal Messages	50
Printing	51
Alarm List	51
Accessories	52
Software	52
Function Key Legend Kits.	52
Memory Cards and Retainer	52
Antiglare Overlay.	53
DH-485 Operating and Programming Cables.	53
PanelView File Transfer Utility	54
Power Supply and Link Couplers	54
RS-232 Cables	55
Remote I/O or DH+ Cable	55
Replacement Parts.	56
Backlight Lamps	56
Real Time Clock Modules.	56
Panel Mount Clips and Studs	57
Remote I/O Connector.	57
Power Input Connector	57

Chapter 2

Applying Power and Resetting Terminal

Chapter Objectives	59
Wiring and Safety Guidelines.	59
Hazardous Location Considerations	60
Connect AC Power	61
Connect dc Power.	63
Reset the Terminal	66
Power-up Sequence	67
For DH-485 and RS-232 Terminals	67
For Remote I/O Terminals	68

Chapter 3

Configuring the Terminal

Chapter Objectives	71
Application Settings.	71
Access the Configuration Mode Menu	72
Operations List	72
Language.	72
Run Mode	73
Reset Video.	73
Comm and Fault Status Indicators.	73

Select a Language	73
Language List	74
Exit	74
Use a Memory Card	74
Memory Card Listing	74
Disconnect Card	74
Applications on Card	74
Restore From Card	75
Save to Card	75
Erase/Format Card	75
Exit	75
Configure Communication	75
DH-485 Communication	75
DH+ Communication	77
Remote I/O Communication	78
ControlNet Communication	79
DeviceNet Communication	82
DF1 Communication	84
EtherNet/IP Communication	86
Configure Presets	88
Power-up with Presets or Last States	88
Restart Unit and Load Values	88
Key Repeat Rate	89
Key Repeat Delay	89
Exit	89
Viewing Terminal Information	89
Boot	89
Firmware	89
Hardware	89
Filename	90
Font File	90
Exit	90
Adjust Screen Parameters	90
PanelView 300 Micro Terminal Screen Setup	90
PanelView 300 Terminal Screen Setup	91
PanelView 550 Terminal Screen Setup	93
PanelView 600/900/1000 Color Terminal Screen Setup	94
PanelView 900 Monochrome Terminal Screen Setup	95
PanelView 1000 Grayscale Terminal Screen Setup	97
PanelView 1400 Color Terminal Screen Setup	98
Set the Time and Date	100
Set the Time	101
Set the Date	101
Exit	101

	Set Up the Printer	102
	Handshaking	102
	Communication Parameters	102
	Baud Rate	103
	Top of Form	103
	Port Mode	103
	Exit	103
	 Chapter 4	
Using a Memory Card	Chapter Objectives	105
	Supported Memory Cards	105
	Use the Memory Card Retainer	106
	Load Application from a Memory Card.	108
	Load Application on a Memory Card	110
	Store Font Files on a Memory Card	111
	Remove a Memory Card	112
	 Chapter 5	
Running Applications	Chapter Objectives	113
	Application Information.	113
	Important Information for PanelView 300 Micro Terminal Operations	113
	Screen Security	114
	Push Button Operation	114
	Control Lists	115
	Active List Item	115
	Active Control List	116
	Cursor	116
	List Keys	117
	Cursor-piloted Control Lists	117
	Numeric Entry Cursor Point	118
	Keypad Enable Button	118
	Scratchpad.	119
	ASCII Entry Controls	121
	ASCII Scratchpad - Keypad or Keypad/Touch Screen Terminals	121
	ASCII Scratchpad - PV300 Micro/300 Terminals.	122
	ASCII Scratchpad - PV550/600 Touch Screen Terminals.	123
	ASCII Scratchpad - PV900/1000/1400 Touch Screen Terminals	124
	ASCII Scratchpads in Other Languages	125
	Screen Selectors	126
	Cursor Operation	127
	List Keys	127
	List Indicators	128

	Multistate Indicators	128
	Bar Graph Displays	128
	Analog Gauges	129
	Numeric Data Displays	129
	Message Displays	129
	Time or Date	130
	Printing	130
	Alarms	131
	Chapter 6	
Installing the PV300 Micro Terminal	Chapter Objectives	133
	Hazardous Location Considerations	133
	Enclosures	134
	Required Tools	134
	Mounting Dimensions	134
	Cutout Dimensions	135
	Clearances	135
	Install Terminal in Panel	136
	Chapter 7	
Installing the PV300 Terminal	Chapter Objectives	139
	Hazardous Location Considerations	139
	Enclosures	140
	Required Tools	140
	Mounting Dimensions	141
	Cutout Dimensions	141
	Clearances	142
	Install the PV300 Terminal in a Panel	143
	Chapter 8	
Installing the PV550 Terminal	Chapter Objectives	145
	Hazardous Location Considerations	145
	Enclosures	146
	Required Tools	147
	Mounting Dimensions	147
	PV550 Keypad, Keypad & Touch Screen Terminals	147
	PV550 Touch Screen Terminals	147
	Clearances	148
	Cutout Dimensions	149
	PV550 Keypad, Keypad and Touch Screen Terminals	149
PV550 Touch Screen Terminals	149	
Install the PV550 Terminal in a Panel	150	

	Chapter 9	
Installing the PV600 Terminal	Chapter Objectives	153
	Hazardous Location Considerations	153
	Enclosures	154
	Required Tools	154
	Mounting Dimensions	155
	PV600 Keypad, Keypad and Touch Screen Terminals . .	155
	PV600 Touch Screen Terminals.	155
	Cutout Dimensions	156
	PV600 Keypad, Keypad and Touch Screen Terminals . .	156
	PV600 Touch Screen Terminals.	156
	Clearances	157
	PV600 Keypad and Keypad and Touch Screen Terminals	157
	PV600 Touch Screen Terminals.	157
Install the PV600 in a Panel.	158	
	Chapter 10	
Installing the PV900/1000 Terminals	Chapter Objectives	161
	Hazardous Location Considerations	161
	Enclosures	162
	Required Tools	162
	PV900 Terminals Mounting Dimensions	163
	PV900 Touch Terminal Mounting Dimensions	163
	PV900 Keypad Terminal Mounting Dimensions.	163
	PV1000 Terminals Mounting Dimensions	164
	PV1000 Touch Terminal Mounting Dimensions	164
	PV1000 Keypad Terminal Mounting Dimensions	164
	Clearances	165
	Cutout Dimensions	166
	PV900 Panel Cutout Dimensions.	166
PV1000 Panel Cutout Dimensions.	166	
Install the PV900/PV1000 Terminals in a Panel.	167	
	Chapter 11	
Installing the PV1400 Terminal	Chapter Objectives	169
	Enclosures	169
	Required Tools	169
	Mounting Dimensions	170
	PV1400 Touch Terminal Mounting Dimensions	170
	PV1400 Keypad Terminal Mounting Dimensions	170
	Clearances	171
	Cutout Dimensions	172
PV1400 Keypad Terminals	172	
PV1400 Touch Screen Terminals.	172	

Terminal Connections

Install the PV1400 Terminal in a Panel	173
Mount Terminal with Mounting Studs	175

Chapter 12

Chapter Objectives	177
Wiring and Safety Guidelines	177
Cable Charts	178
Runtime Communication Cables - to Processors	178
Runtime Communication Cables - to Network Interface Module	183
Application File Upload/Download (Direct) Cables	184
Remote I/O Terminal Connections	185
Remote I/O Terminal Ports	185
Supported Controllers	186
Making Remote I/O Connections	187
Remote I/O Pass-through using DH+	188
DH+ Terminal Connections	189
DH+ Terminal Ports	189
Typical DH+ System Configuration	190
Making DH+ Connections	191
DH-485 Terminal Connections	192
DH-485 Terminal Ports (RJ45)	192
Connecting to a Single SLC Controller (Point-to-point)	193
Connecting to a DH-485 Network	194
Connecting a Computer	196
Connecting a Hand-held Terminal	198
RS-232 (DH-485) Terminal Connections	199
RS-232 Terminal Ports	199
Connecting to an SLC, CompactLogix, MicroLogix Controller (Point-to-point)	200
Connecting to a MicroLogix Controller through an AIC+ Module	201
Connecting a Computer	201
Connecting a DH+ to DH-485 Pass-through Link	202
RS-232 (DF1) Terminal Connections	202
Compatible Controllers	203
RS-232 (DF1) Terminal Ports	203
RS-232/DF1 Port Connector	204
Connecting to a MicroLogix 1000 Controller	204
Connecting to an SLC, PLC, or MicroLogix 1500LRP Controller	205
Connecting to a CompactLogix or FlexLogix	205
Using a Modem	206
Connecting to a DeviceNet or EtherNet/IP Network	206
Constructing a Null Modem Cable	207

ControlNet Connections	207
Related Information	207
ControlNet Protocol	208
Compatible ControlNet Controllers	208
ControlNet Terminal Ports	208
Typical ControlNet Network	209
Making ControlNet Connections	210
NAP and Redundant Cables	211
DeviceNet Network Terminal Connections	212
DeviceNet Terminal Ports	212
Making DeviceNet Connections	213
Typical DeviceNet Network	214
EtherNet/IP Connections	215
EtherNet/IP Terminal Ports	215
Ethernet Connector	216
Cables	216
Typical EtherNet/IP Configuration	217
PanelView 300 Micro Terminal Connections	218
RS-232 Communication Port	218
Connecting to a MicroLogix Controller	218
Connecting to an SLC, PLC-5, ControlLogix, MicroLogix 1500LRP, CompactLogix, or FlexLogix	219
Connecting to an Advanced Interface Converter	220
Connecting to a DeviceNet Interface (DNI)	220
Connecting to a Personal Computer (Application File Transfers)	221
Connecting a Computer or Printer to the Terminal	223

Chapter 13

Troubleshooting and Maintenance

Chapter Objectives	225
Equipment Required	225
Use the Troubleshooting Chart	225
Interpret Status Indicators	229
Clean the Display Window	231
Remove Paint and Grease	231
Equipment Hose-downs	231
Replace the Clock Module	232
Replace the Backlight	232

Appendix A

Specifications

PanelView 300 Micro Terminal	233
PanelView 300 Terminal	234
PanelView 550 Terminals	236
PanelView 600 Color Keypad and Touch Terminals	238
PanelView 600 Color Touch Only Terminals	239

PanelView 900 Monochrome and Color Terminals	240
PanelView 1000 Color & Grayscale	244
PanelView 1400 Color	245
Communication.	247
Agency Certifications.	248

Appendix B

Messages, Codes and Self-test Numbers

Types of Terminal Messages	249
Status Messages	249
Reminder Messages	249
Warning Messages	249
Fault Messages.	249
General Terminal Messages	250
DH-485 Terminal Messages	254
ControlNet Terminal Messages	255
Remote I/O Terminal Messages	256
EtherNet/IP Messages.	256
DH+ Terminal Messages.	257
DF1 Terminal Messages	258
Terminal Codes.	258
DeviceNet Codes	258
General Codes.	262
ControlNet Codes.	262
EtherNet/IP Codes	263
Remote I/O Communication Loss.	267
Self-test Numbers	267

Appendix C

European Union Directive Compliance

EMC and Low Voltage Directives	269
Intended Use of Product	270
Wiring Recommendations.	270
Declarations of Conformity.	270
Battery Replacement and Disposal	271

Glossary

Index

Objectives

Read this preface to familiarize yourself with the rest of this manual.

- Intended audience
- Conventions used
- Terminology
- Installing PanelView terminals
- European Union Directive Compliance
- Related publications
- Technical support

Intended Audience

No special knowledge is required to understand this manual or operate the PanelView terminals. Before running an application, you must know the functions of all screens and screen objects. This information is available from the application designer.

Equipment installers must be familiar with standard panel installation techniques.

Conventions

The manual uses these conventions:

- For specific PanelView terminals, PanelView is replaced with the PV abbreviation. For example: PV1000 refers to the PanelView 1000 terminal.
- PanelView terminal refers to any one of the PanelView terminals.

Terminology

This manual contains some terms that may be unfamiliar.

Use the Glossary on [page 273](#) of this manual for assistance.

Installing PanelView Terminals

Each terminal is shipped with installation instructions and a panel cutout. Please follow these instructions when installing your PanelView terminal in a panel or enclosure.

European Union Directive Compliance

Refer to [Appendix C](#) for details on installing the PanelView terminals in industrial environments requiring compliance with European Union Directives.

Additional Resources

Refer to the extensive online help for the PanelBuilder32 Software or the following publications if necessary.

Resource	Description
PanelBuilder32 Software Getting Results Manual, publication 2711-GR003	Information about using PanelBuilder32 software
PanelBuilder32 Quick Start Manual, publication 2711-QS003	Information about starting PanelBuilder32 software
WinPFT File Transfer Utility, publication 2711-TD006	Information about the WinPFT file transfer utility
PROFIBUS DP Communication for PanelView Terminals, publication 2711-6.3	Information about PROFIBUS DP communication for PanelView terminals
Modbus Communication for PanelView Terminals, publication 2711-6.9	Information about Modbus communication for PanelView terminals
Programmable Controller Wiring and Grounding Guidelines, publication 1770-4.1	Information on wiring and grounding
Data Highway/Data Highway Plus/Data Highway-485 Cable Installation Manual, publication 1770-6.2.2	Information about installing Data Highway/Data Highway Plus/Data Highway-485 cable

For information relating to your controller, refer to the appropriate manual.

Technical Support

If you have questions about the PanelView terminals or the PanelBuilder32 software, please refer to the online manuals or online help provided with the PanelBuilder32 installation CD. These publications are also available from the literature library at:

<http://literature.rockwellautomation.com>

Frequently Asked Questions

Documents on frequently asked questions are available at:

<http://www.rockwellautomation.com/knowledgebase>

Software and Firmware Upgrades

To receive software updates (software serial number required) and firmware upgrades for your PanelView terminal:

- locate on PanelBuilder32 installation CD.
- call Rockwell Software at 1-440-646-7700 or fax 1-440-646-7701.
- access www.software.rockwell.com.

Terminal Overview

Chapter Objectives

This chapter gives an overview of the PanelView Operator Terminals.

- Intended uses
- Terminal types and features
- Applications
- Configuration mode
- Terminal messages
- Printing
- Accessories and replacement parts

Intended Uses

You can use the PanelView operator terminals for a wide variety of machine control and monitoring applications.

ATTENTION



Do not use a PanelView terminal for emergency stops or other controls critical to the safety of personnel or equipment. Use separate hardwired operator interface devices that do not depend on solid state electronics. See the inside front cover of this manual for guidelines.

Terminal Types

PanelView terminals are available in a variety of options.

- Display size and type (monochrome, grayscale, color)
- Operator input (touch screen or keypad)
- Communication port (DH-485, RS-232, remote I/O, DH+, ControlNet, DeviceNet, Ethernet, EtherNet/IP, DF1)
- RS-232 printer port support

In addition, some terminals are available with:

- AC or DC power (L1 at the end of a catalog number indicates a DC terminal, for example, 2711-B5A1L1, or -T9C1L1).
- stainless steel bezel available on PanelView 550 keypad or keypad & touch terminals.

Contact your Allen-Bradley representative for availability.

Color and Grayscale Terminals

Color terminals support a fixed palette of 32 standard EGA colors. Grayscale terminals support a fixed palette of four colors (shades of gray). All color in an application is defined when the application is created. Colors are not selectable at the terminal.

PanelView 300 Monochrome Terminals

The PanelView 300 terminal is only available with 24V DC input power.

Operator Input	Communication Port				Printer Port RS-232	Catalog Number
	DH-485	RS-232 (DH-485)	DeviceNet	RS-232 (DF1)		
Keypad	x					2711-K3A2L1
		x				2711-K3A5L1
			x		x	2711-K3A10L1
				x		2711-K3A17L1

PanelView 300 Micro Monochrome Terminals

The PanelView 300 Micro terminal is available only with 24V DC input power and does not have a printer port. The PV300 Micro terminal contains a single RS-232 communication port which supports either DF1 or DH485 communication protocols as specified in the table below.

Operator Input	Communication Port		Catalog Number
	DH-485	DF1	
Keypad	x		2711-M3A19L1
		x	2711-M3A18L1

PanelView 550 Monochrome Terminals

The touch screen version of the PanelView 550 terminal is available only with 24V DC power. The L1 in the catalog number indicates DC power.

Operator Input	Communication Port								Printer Port RS-232	Catalog Number ⁽¹⁾
	RIO	DH-485	RS-232 (DH-485)	DH+	DeviceNet	ControlNet	RS-232 (DF1)	Ethernet		
Touch Screen and Keypad	x								x	2711-B5A1
		x								2711-B5A2
		x							x	2711-B5A3
			x							2711-B5A5
				x					x	2711-B5A8
			x						x	2711-B5A9
					x				x	2711-B5A10
						x			x	2711-B5A15
							x		x	2711-B5A16
Keypad								x	x	2711-B5A20
	x								x	2711-K5A1
		x								2711-K5A2
		x							x	2711-K5A3
			x							2711-K5A5
				x					x	2711-K5A8
			x						x	2711-K5A9
					x				x	2711-K5A10
						x			x	2711-K5A15
Touch Screen (24V DC only)							x		x	2711-K5A16
								x	x	2711-K5A20
	x								x	2711-T5A1L1
		x								2711-T5A2L1
		x							x	2711-T5A3L1
			x							2711-T5A5L1
				x					x	2711-T5A8L1
			x						x	2711-T5A9L1
					x				x	2711-T5A10L1
					x			x	2711-T5A15L1	
						x		x	2711-T5A16L1	
							x	x	2711-T5A20L1	

⁽¹⁾ Add L1 to the end of the catalog number for 24V DC power.
 Add L2 to the end of a catalog number for stainless steel. Not available for the touch screen terminals.
 Add L3 to the end of a catalog number for 24V DC power and stainless steel. Stainless steel is not available for the touch screen terminals.

PanelView 600 Color Terminals

Operator Input	Communication Port								Printer Port RS-232	Catalog Number ⁽¹⁾
	RIO	DH-485	RS-232 (DH-485)	DH+	DeviceNet	ControlNet	RS-232 (DF1)	Ethernet		
Touch Screen and Keypad	x								x	2711-B6C1
		x								2711-B6C2
		x							x	2711-B6C3
			x							2711-B6C5
				x					x	2711-B6C8
			x						x	2711-B6C9
					x				x	2711-B6C10
						x			x	2711-B6C15
							x		x	2711-B6C16
Keypad								x	x	2711-B6C20
	x								x	2711-K6C1
		x								2711-K6C2
		x							x	2711-K6C3
			x							2711-K6C5
				x					x	2711-K6C8
			x						x	2711-K6C9
					x				x	2711-K6C10
						x			x	2711-K6C15
Touch Screen (24V DC only)							x		x	2711-K6C16
								x	x	2711-K6C20
	x								x	2711-T6C1L1
		x								2711-T6C2L1
		x							x	2711-T6C3L1
			x							2711-T6C5L1
				x					x	2711-T6C8L1
			x						x	2711-T6C9L1
					x				x	2711-T6C10L1
					x			x	2711-T6C15L1	
						x		x	2711-T6C16L1	
							x	x	2711-T6C20L1	

⁽¹⁾ Add L1 to the end of the catalog number for 24V DC power.

PanelView 900 Monochrome Terminals

These terminals are no longer available for purchase.

Operator Input	Communication Port							Printer Port RS-232	Catalog Number ⁽¹⁾
	RIO	DH-485	RS-232 (DH-485)	DH+	DeviceNet	ControlNet	RS-232 (DF1)		
Touch Screen	x							x	2711-T9A1
		x							2711-T9A2
		x						x	2711-T9A3
			x						2711-T9A5
				x				x	2711-T9A8
			x					x	2711-T9A9
					x			x	2711-T9A10
							x	x	2711-T9A15
Keypad							x	x	2711-T9A16
	x							x	2711-K9A1
		x							2711-K9A2
		x						x	2711-K9A3
			x						2711-K9A5
				x				x	2711-K9A8
			x					x	2711-K9A9
					x			x	2711-K9A10
						x	x	2711-K9A15	
							x	x	2711-K9A16

⁽¹⁾ Add L1 to the end of the catalog number for 24V DC power.

PanelView 900 Color Terminals

These terminals are no longer available for purchase.

Operator Input	Communication Port								Printer Port RS-232	Catalog Number ⁽¹⁾
	RIO	DH-485	RS-232 (DH-485)	DH+	DeviceNet	ControlNet	RS-232 (DF1)	Ethernet		
Touch Screen	x								x	2711-T9C1
		x							x	2711-T9C3
				x					x	2711-T9C8
			x						x	2711-T9C9
					x				x	2711-T9C10
						x			x	2711-T9C15
							x		x	2711-T9C16
								x	x	2711-T9C20
Keypad	x								x	2711-K9C1
		x							x	2711-K9C3
				x					x	2711-K9C8
			x						x	2711-K9C9
					x				x	2711-K9C10
						x			x	2711-K9C15
							x		x	2711-K9C16
								x	x	2711-K9C20

⁽¹⁾ Add L1 to the end of the catalog number for 24V DC power.

PanelView 1000 Color Terminals

Operator Input	Communication Port								Printer Port RS-232	Catalog Number ⁽¹⁾
	RIO	DH-485	RS-232 (DH-485)	DH+	DeviceNet	ControlNet	RS-232 (DF1)	Ethernet		
Touch Screen	x								x	2711-T10C1
		x							x	2711-T10C3
				x					x	2711-T10C8
			x						x	2711-T10C9
					x				x	2711-T10C10
						x			x	2711-T10C15
							x		x	2711-T10C16
								x	x	2711-T10C20
Keypad	x								x	2711-K10C1
		x							x	2711-K10C3
				x					x	2711-K10C8
			x						x	2711-K10C9
					x				x	2711-K10C10
						x			x	2711-K10C15
							x		x	2711-K10C16
								x	x	2711-K10C20

⁽¹⁾ Add L1 to the end of the catalog number for 24V DC power.

PanelView 1000 Grayscale Terminals

Operator Input	Communication Port								Printer Port RS-232	Catalog Number ⁽¹⁾
	RIO	DH-485	RS-232 (DH-485)	DH+	DeviceNet	ControlNet	RS-232 (DF1)	Ethernet		
Touch Screen	x								x	2711-T10G1
		x							x	2711-T10G3
				x					x	2711-T10G8
			x						x	2711-T10G9
					x				x	2711-T10G10
						x			x	2711-T10G15
							x		x	2711-T10G16
								x	x	2711-T10G20
Keypad	x								x	2711-K10G1
		x							x	2711-K10G3
				x					x	2711-K10G8
			x						x	2711-K10G9
					x				x	2711-K10G10
						x			x	2711-K10G15
							x		x	2711-K10G16
								x	x	2711-K10G20

⁽¹⁾ Add L1 to the end of the catalog number for 24V DC power.

PanelView 1400 Color Terminals

These terminals are no longer available for purchase.

Operator Input	Communication Port								Printer Port RS-232	Catalog Number
	RIO	DH-485	RS-232 (DH-485)	DH+	DeviceNet	ControlNet	RS-232 (DF1)	Ethernet		
Touch Screen	x								x	2711-T14C1
		x							x	2711-T14C3
				x					x	2711-T14C8
			x						x	2711-T14C9
					x				x	2711-T14C10
						x			x	2711-T14C15
							x		x	2711-T14C16
									x	2711-T14C20
Keypad	x							x	x	2711-K14C1
		x							x	2711-K14C3
				x					x	2711-K14C8
			x						x	2711-K14C9
					x				x	2711-K14C10
						x			x	2711-K14C15
							x		x	2711-K14C16
								x	x	2711-K14C20

PanelView 300 Micro Terminal Features

This section defines features of the PanelView 300 Micro keypad terminal.

PanelView 300 Micro Terminal Features (front)

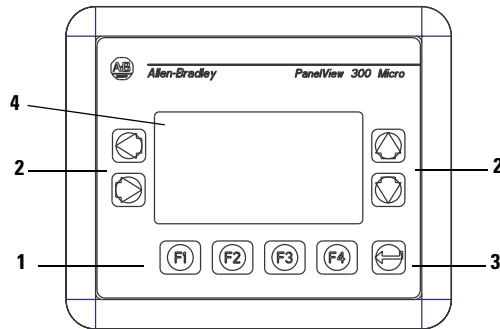

#	Feature	Description
1	Function keys (F1...F4)	Use the function keys to initiate functions on the terminal display.
2	Cursor keys	Use the cursor keys (left, right, up, down) as programmed function keys in addition to the F1...F4 function keys or to move the cursor in displayed lists, to select a numeric entry object, to enter configuration mode, or to enter/modify numeric and ascii data.
3	↵	Stores an entered value.
4	Keypad terminal display	Liquid crystal display with integral backlight. Displays application text, controls, graphics.

PanelView 300 Micro Terminal Features (back)

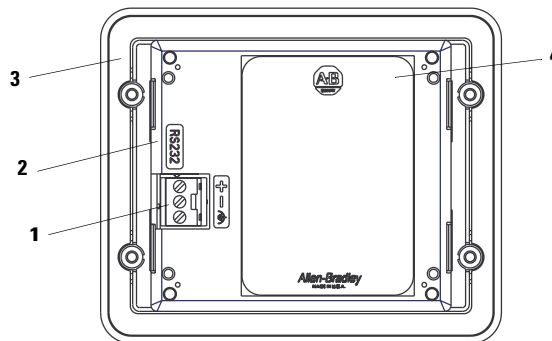

#	Feature	Description
1	Power connection terminals	Connects to a 24V DC (11-30V DC) external power source.
2	DF1 or DH-485 (RS232) communication port	Connects to an SLC, PLC, or MicroLogix controller by using an RS-232 connection. Also used for downloading applications directly from a computer.
3	Sealing gasket	Seals the front of the terminal to an enclosure or panel.
4	Nameplate label	Provides product information.

PanelView 300 Terminal Features

This section defines features of the PanelView 300 keypad terminal.

PanelView 300 Terminal Features (front)

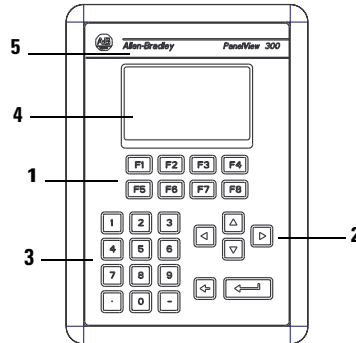

#	Feature	Description
1	Function keys (F1...F8)	Use the function keys to initiate functions on the terminal display. These keys may have custom legends.
2	Cursor keys	Use the up or down cursor keys to move the cursor up or down in a list or to increment/decrement values. Use the left or right cursor keys to select an object with an indicator bar, or to enter configuration mode.
3	Numeric entry keys	<p>0...9 - Enters numeric values.</p> <p>. - Enters a decimal point.</p> <p>- - Enters a negative value.</p> <p>← - Clears entered digits or cancels the scratchpad.</p> <p>↵ - Stores an entered value.</p>
4	Keypad terminal display	Initiate the function of a displayed object, such as an ON or OFF push button, by pressing the corresponding function key (F1...F8).
5	OEM label option (series B and later)	Contact Rockwell Automation or your authorized distributor for custom label information.

The following illustration shows the dimensions for the OEM label.

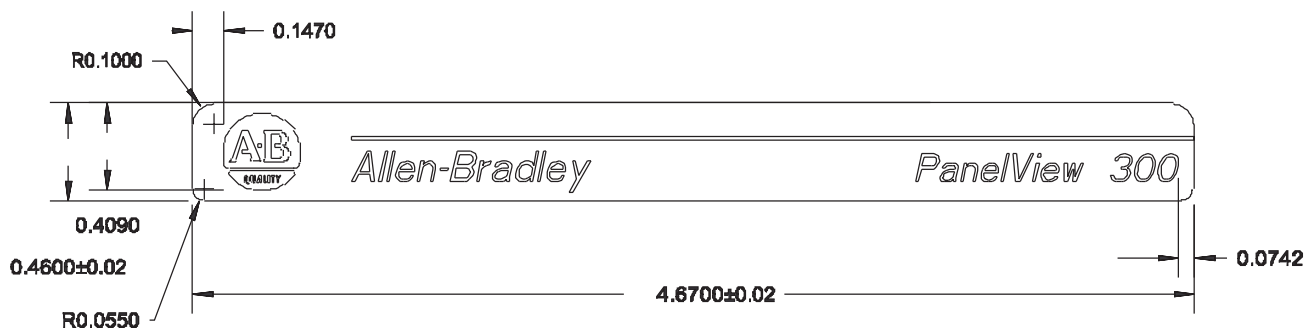

PanelView 300 Terminal Features (back)

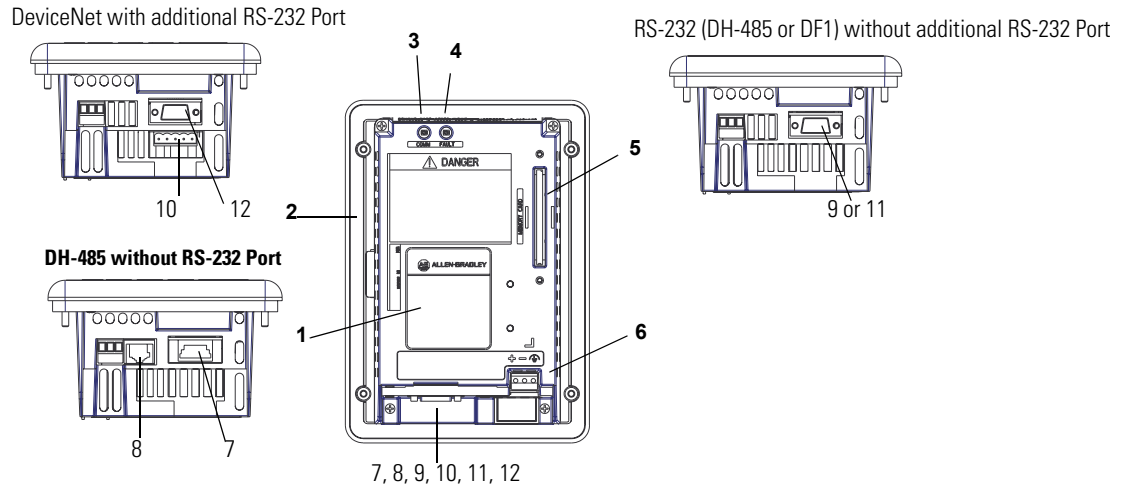

#	Feature	Description
1	Nameplate label	Provides product information.
2	Sealing gasket	Seals the front of the terminal to an enclosure or panel.
3	COMM Status indicator (green)	Indicates when communication is occurring.
4	FAULT Status indicator (red)	Indicates firmware or hardware faults.
5	Memory card slot	Accepts a memory card which stores applications.
6	Power connection terminals	Connects to an external 24V DC power source (18...32V DC).
7	DH-485 communication port	Connects to an SLC or MicroLogix controller, DH-485 network, or Wallmount Power Supply (Cat. No. 1747-NP1).
8	DH-485 programming connector	Connects to a Personal Computer Interface Converter (Cat. No. 1747-PIC) for transferring applications. Also connects to an SLC programmer, such as the Hand-held Terminal (Cat. No. 1747-PT1).
9	RS-232 (DH-485) communication port	Connects to the Channel 0 port of an SLC 5/03, SLC 5/04, or SLC 5/05 controller for point-to-point DH-485 communication. Connects to a MicroLogix controller through an AIC+ Link Coupler. Also connects to the RS-232 serial port of a computer for transferring applications.
10	DeviceNet connector	Connects to a DeviceNet network.
11	RS-232 (DF1) communication port	Connects to a PLC, SLC, or MicroLogix controller with a DF1 port. This port also connects to the RS-232 port of a computer.
12	RS-232 Printer/File transfer port	Connects to a printer (K3A10L1 version only). On a DeviceNet terminal, this port also connects to the RS-232 port of a computer for transferring applications.

PanelView 550 Terminal Features

This section defines features of the PanelView 550 terminals.

PanelView 550 Terminal Features (front)

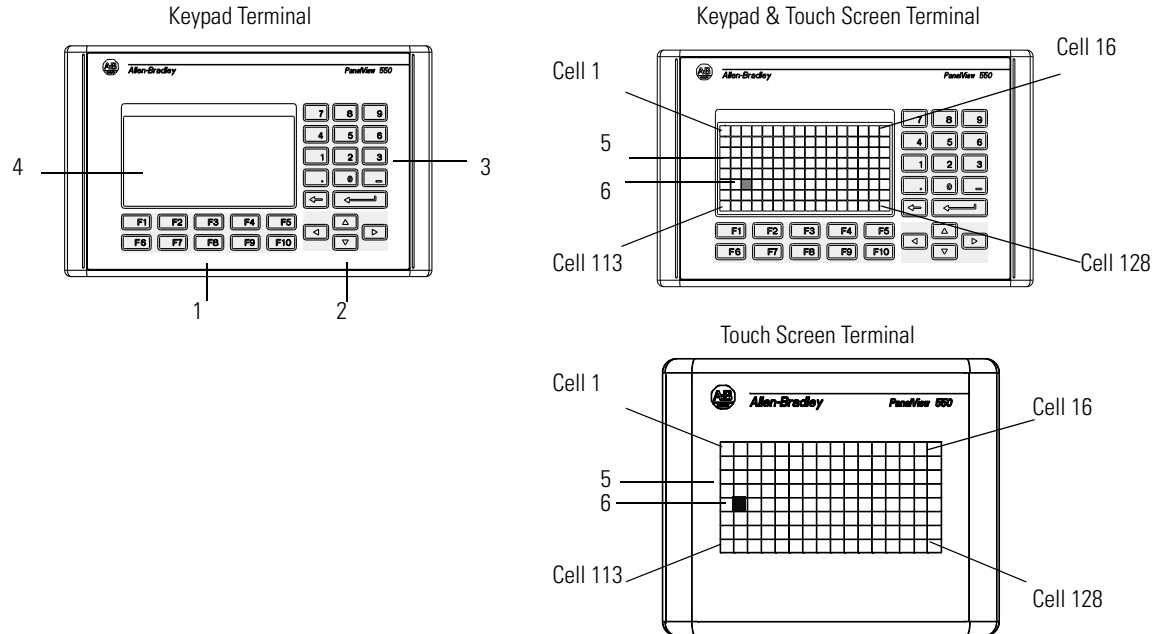

#	Feature	Description
1	Function Keys (F1...F10)	On keypad terminals, use the function keys to initiate functions on the terminal display. These keys may have custom legends. On keypad and touch screen terminals, you can initiate functions by using the function keys and/or touch screen objects.
2	Cursor Keys	Use the cursor keys to move the cursor in displayed lists, to select a numeric entry object, or to enter configuration mode.
3	Numeric Entry Keys	0...9 - Enters numeric values. . - Enters a decimal point. - - Enters a negative value. ← - Clears entered digits or cancels the scratchpad. ↵ - Stores an entered value.
4	Keypad Terminal Display	On keypad terminals, initiate the function of a displayed object, such as an ON or OFF push button, by pressing a function key (F1...F10).
5	Touch Screen Terminal Display	On touch screen or keypad & touch screen terminals, initiate the function of a displayed object, such as an ON or OFF push button, by touching the screen object. Each interactive screen object occupies one or more of 128 cells. On keypad and touch screen terminals, you can initiate functions by using the function keys and/or touch screen objects.
6	Touch Cells (Touch Screen terminal)	The 128 touch cells (16 columns x 8 rows) let you initiate functions by touching the screen. Interactive screen objects are aligned with touch cells when the application is created.

PanelView 550 Keypad or Keypad and Touch Screen Terminals (back)

DH-485 without additional RS-232 Port

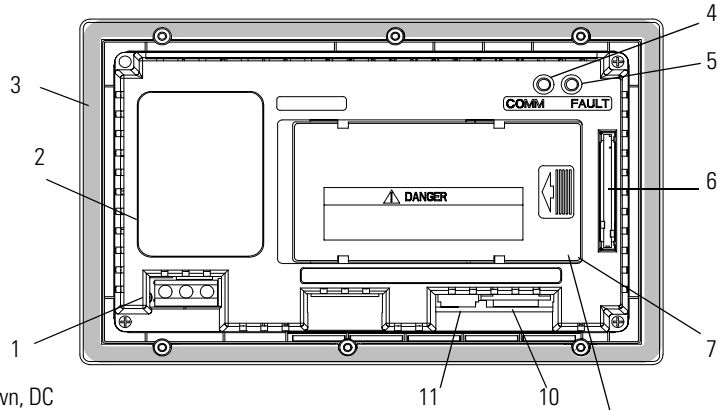

AC connector shown, DC connector looks different

DH-485 with additional RS-232 Port

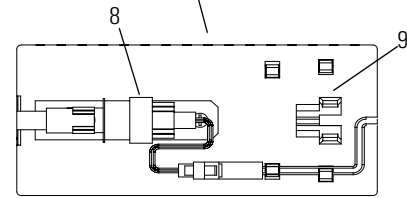
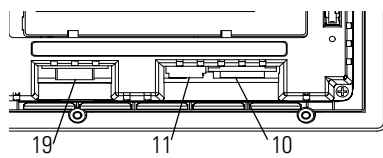

Backlight lamp behind access cover
Series G and earlier

RS-232 (DH-485)
without additional RS-232 Port

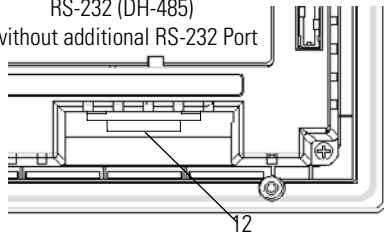

Remote I/O, DF1, DH+, DeviceNet, ControlNet, Ethernet,
with additional RS-232 Port

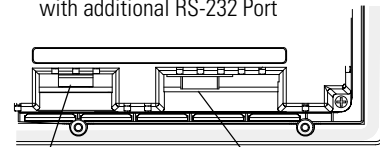

RS-232 (DH-485)
with additional RS-232 Port

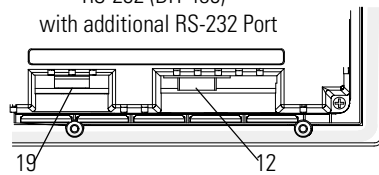

#	Feature	Description
1	Power Connection Terminals	Connects to external power source.
2	Nameplate Label	Provides product information.
3	Sealing Gasket	Seals the front of the terminal to an enclosure or panel.
4	COMM Status (Green) Indicator	Indicates when communication is occurring.
5	FAULT Status (Red) Indicator	Indicates firmware or hardware faults.
6	Memory Card Slot	Accepts a memory card which stores applications.
7	Access Cover	Provides access to the replaceable backlight lamp.
8	Backlight Lamp	Light source for the display backlight. Light transmits through a fiber-optic bundle to the back of the LCD display. ⁽¹⁾
9	Spare Bulb Holder	Stores a spare backlight lamp. ⁽¹⁾
10	DH-485 Communication Port	Connects to an SLC or MicroLogix controller, DH-485 network, or Wallmount Power Supply (Cat. No. 1747-NP1).
11	DH-485 Programming Connector	Connects to a Personal Computer Interface Converter (Cat. No. 1747-PIC) for transferring applications. Also connects to an SLC programmer, such as the Hand-held Terminal (Cat. No. 1747-PT1).
12	RS-232 (DH-485) Communication Port	Connects to the Channel 0 port of an SLC 5/03, SLC 5/04, or SLC 5/05 controller for point-to-point DH-485 communication. Connects to a MicroLogix controller through an AIC+ Link Coupler. Also connects to the RS-232 serial port of a computer for transferring applications.
13	Remote I/O Port	Connects to a scanner or sub-scanner on a remote I/O network.
14	DH+ Communication Port	Connects to a PLC-5, SLC 5/04, or ControlLogix controller on a DH+ link.
15	DeviceNet Connector	Connects to a DeviceNet network.
16	ControlNet Connector	Connects to a ControlLogix controller (with 1756-CNB module) or PLC-5 on a ControlNet network.
17	RS-232 (DF1) Communication Port	Connects to a PLC, SLC, or MicroLogix controller with a DF1 port.
18	Ethernet Connector	Connects to a PLC-5E or SLC 5/05 controller, or a ControlLogix, MicroLogix, FlexLogix, or CompactLogix controller (with appropriate bridge module) on an EtherNet/IP network.
19	RS-232 Printer/ File Transfer Port	Connects to a printer. On remote I/O, DH+, DF1, DeviceNet, EtherNet/IP, or ControlNet terminals, this port also connects to the RS-232 port of a computer for transferring applications. The RS-232 port on the DH-485 or RS-232 (DH-485) terminal is used to connect a printer but not for file transfers.

⁽¹⁾ Series H and later PanelView 550 Keypad and Keypad Touch Terminals have an integrated LED backlight. This backlight is non-replaceable.

PanelView 550 Touch Screen Terminal Features (back)

DH-485 without additional RS-232 Port

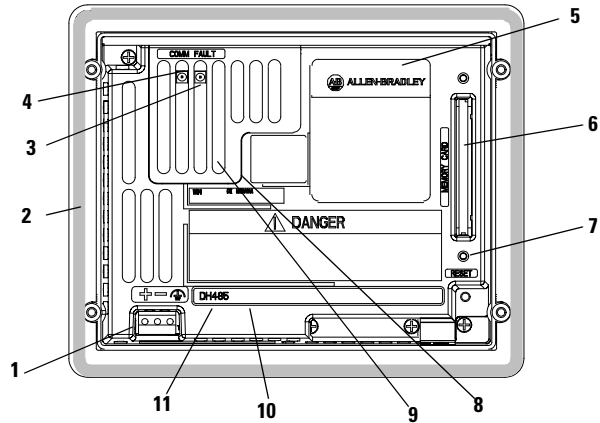

DH-485 with RS-232 Port

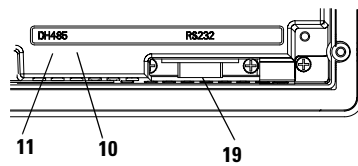

Backlight lamp behind access cover
Series A only

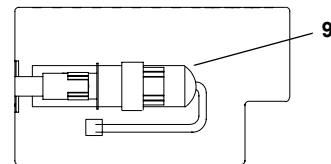

RS-232 (DH-485) without additional RS-232 Port

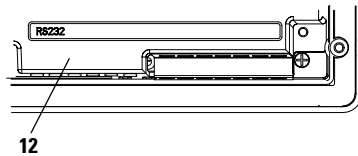

Remote I/O, DF1, DH+, DeviceNet,
ControlNet, Ethernet, with RS-232 Port

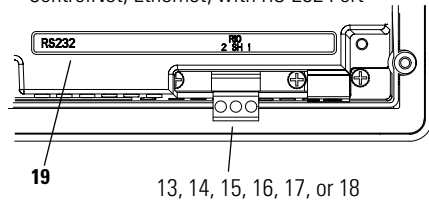

RS-232 (DH-485) with additional RS-232 Port

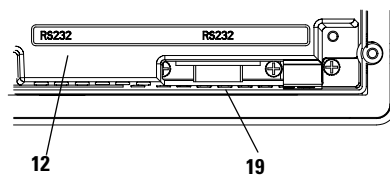

#	Feature	Description
1	Power Connection Terminals	Connects to external DC power source.
2	Sealing Gasket	Seals the front of the terminal to an enclosure or panel.
3	FAULT Status (Red) Indicator	Indicates firmware or hardware faults.
4	COMM Status (Green) Indicator	Indicates when communication is occurring.
5	Nameplate Label	Provides product information.
6	Memory Card Slot	Accepts a memory card which stores applications.
7	Reset Button	Resets the terminal.
8	Access Cover	Provides access to the replaceable backlight lamp. ⁽¹⁾
9	Backlight Lamp	Light source for the display backlight. ⁽¹⁾
10	DH-485 Communication Port	Connects to an SLC or MicroLogix controller, DH-485 network, or Wallmount Power Supply (Cat. No. 1747-NP1).
11	DH-485 Programming Connector	Connects to a Personal Computer Interface Converter (Cat. No. 1747-PIC) for transferring applications. Also connects to an SLC programmer, such as the Hand-held Terminal (Cat. No. 1747-PT1).
12	RS-232 (DH-485) Communication Port	Connects to the Channel 0 port of an SLC 5/03, 5/04, or 5/05 for point-to-point DH-485 communication. Connects to a MicroLogix controller through an AIC+ Link Coupler. Also connects to the RS-232 serial port of a computer for transferring applications.
13	Remote I/O Port	Connects to a scanner or sub-scanner on a remote I/O network.
14	DH+ Communication Port	Connects to a PLC-5, SLC 5/04, or ControlLogix controller on a DH+ link.
15	DeviceNet Connector	Connects to a DeviceNet network.
16	ControlNet Connector	Connects to a ControlLogix controller (with 1756-CNB module) or PLC-5 on a ControlNet network.
17	RS-232 (DF1) Communication Port	Connects to a PLC, SLC, or MicroLogix controller with a DF1 port.
18	Ethernet Connector	Connects to a PLC-5E or SLC 5/05 controller, or a ControlLogix, MicroLogix, FlexLogix or CompactLogix (with appropriate bridge module) on an EtherNet/IP network.
19	RS-232 Printer/File Transfer Port	Connects to a printer. On remote I/O, DH+, DF1, DeviceNet, EtherNet/IP, or ControlNet terminals, this port also connects to the RS-232 port of a computer for transferring applications. The RS-232 port on the DH-485 or RS-232 (DH-485) terminal is used to connect a printer but not for file transfers.

⁽¹⁾ Series B and later PanelView 550 Touch Terminals have an integrated LED backlight. This backlight is non-replaceable.

PanelView 600 Terminal Features

This section defines features of the PanelView 600 terminals.

PanelView 600 Terminal Features (front)

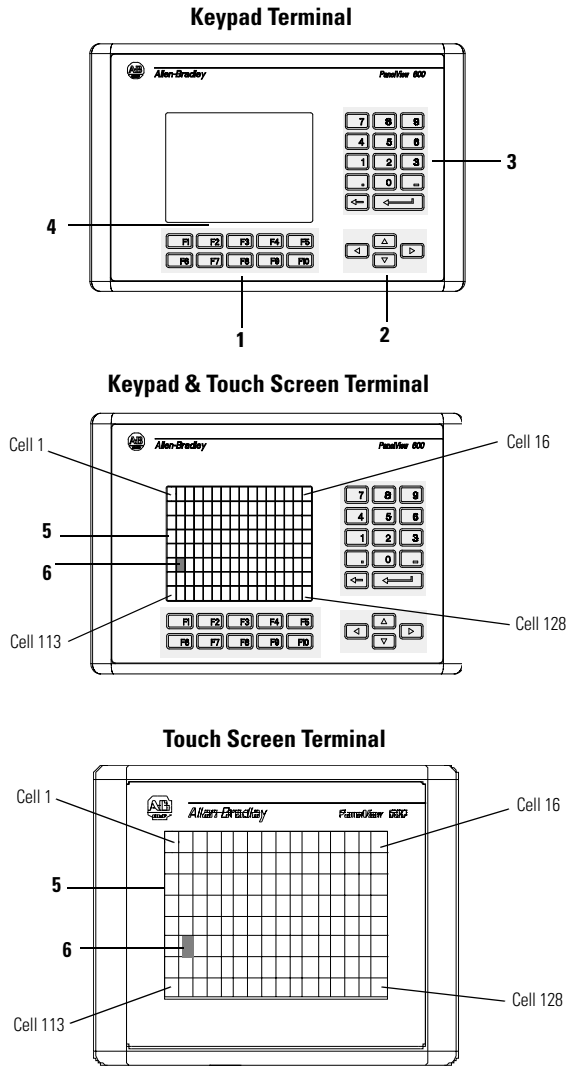

#	Feature	Description
1	Function Keys (F1...F10)	<p>Use the function keys on keypad terminals to initiate functions on the terminal display. These keys may have custom legends.</p> <p>On the keypad & touch screen terminals, you can initiate functions by using the function keys and/or touch screen objects.</p>
2	Cursor Keys	Use the cursor keys to move the cursor in displayed lists, to select a numeric entry object, or to enter configuration mode.
3	Numeric Entry Keys	<p>0...9 - Enters numeric values.</p> <p>. - Enters a decimal point.</p> <p>- - Enters a negative value.</p> <p>← - Clears entered digits or cancels the scratchpad.</p> <p>↵ - Stores an entered value.</p>
4	Keypad Terminal Display	On keypad terminals, initiate the function of a displayed object, such as an ON or OFF push button, by pressing a function key (F1...F10).
5	Touch Screen Terminal Display	<p>On keypad and touch screen terminals, initiate the function of a displayed object, such as an ON or OFF push button, by touching the screen object. Each interactive screen object occupies one or more of 128 cells.</p> <p>On touch screen and keypad terminals, you can initiate functions, by using the function keys and/or touch screen objects.</p>
6	Touch Cells (Touch Screen terminal)	The 128 touch cells (16 columns x 8 rows) let you initiate functions by touching the screen. Interactive screen objects are aligned with touch cells when the application is created.

PanelView 600 Keypad or Keypad & Touch Screen Terminal (back)

Remote I/O, DF1, DH+, DeviceNet, ControlNet, or Ethernet with additional RS-232 Port

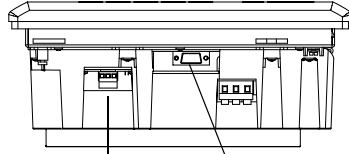

10, 11, 12, 13, 14, or 15 16

DH-485 without additional RS-232 Port

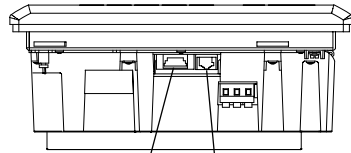

7 8

DH-485 with additional RS-232 Port

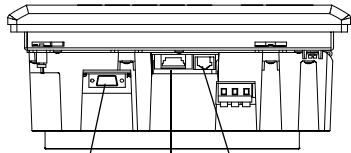

16 7 8

**RS-232 (DH-485)
without additional RS-232 Port**

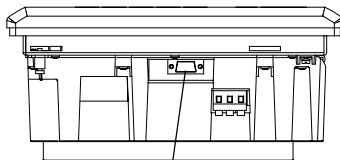

9

RS-232 (DH-485) with additional RS-232 Port

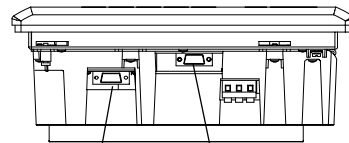

16 9

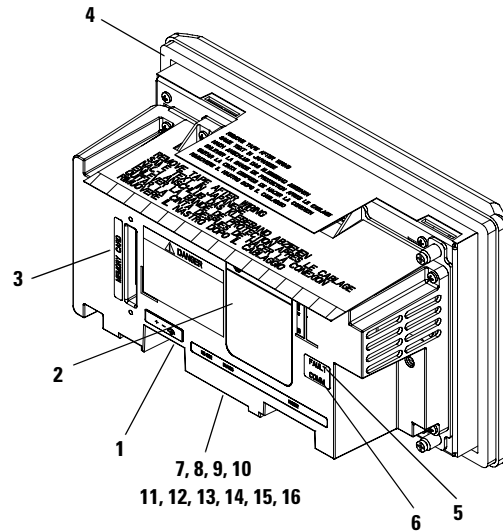

7, 8, 9, 10
11, 12, 13, 14, 15, 16

#	Feature	Description
1	Power Connection Terminals	Connects to external power source.
2	Nameplate Label	Provides product information.
3	Memory Card Slot	Accepts a memory card which stores applications.
4	Sealing Gasket	Seals the front of the terminal to an enclosure or panel.
5	FAULT Status (Red) Indicator	Indicates firmware or hardware faults.
6	COMM Status (Green) Indicator	Indicates when communication is occurring.
7	DH-485 Communication Port	Connects to an SLC or MicroLogix controller, DH-485 network, or Wallmount Power Supply (Cat. No. 1747-NP1).
8	DH-485 Programming Connector	Connects to a Personal Computer Interface Converter (Cat. No. 1747-PIC) for transferring applications. Also connects to an SLC programmer, such as the Hand-held Terminal (Cat. No. 1747-PT1).
9	RS-232 (DH-485) Communication Port	Connects to the Channel 0 port of an SLC 5/03, 5/04, or 5/05 for point-to-point DH-485 communication. Connects to a MicroLogix controller through an AIC+ Link Coupler. Also connects to the RS-232 serial port of a computer for transferring applications.
10	Remote I/O Port	Connects to a scanner or sub-scanner on a remote I/O network.
11	DH+ Communication Port	Connects to a PLC-5, SLC 5/04, or ControlLogix controller on a DH+ link.
12	DeviceNet Connector	Connects to a DeviceNet network.
13	ControlNet Connector	Connects to a ControlLogix controller (with 1756-CNB module) or PLC-5 on a ControlNet network.
14	(RS-232) DF1 Communication Port	Connects to a PLC, SLC, or MicroLogix controller with a DF1 port.
15	Ethernet Connector	Connects to a PLC-5E or SLC 5/05 controller, or a ControlLogix, MicroLogix, FlexLogix, or CompactLogix (with appropriate bridge module) on an EtherNet/IP network.
16	RS-232 Printer/File Transfer Port	Connects to a printer. On remote I/O, DH+, DF1, DeviceNet, EtherNet/IP, or ControlNet terminals, this port also connects to the RS-232 port of a computer for transferring applications. The RS-232 port on the DH-485 or RS-232 (DH-485) terminal is used to connect a printer but not for file transfers.

PanelView 600 Touch Screen Terminal Features (back)

Remote I/O, DF1, DH+, DeviceNet, ControlNet, or Ethernet with additional RS-232 Port

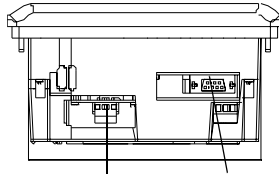

11, 12, 13, 14, 15, or 16

DH-485 without additional RS-232 Port

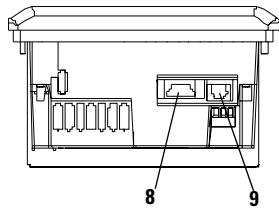

8 9

DH-485 with additional RS-232 Port

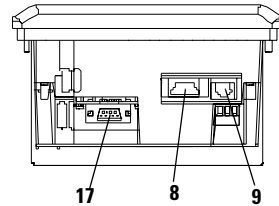

17 8 9

RS-232 (DH-485) without additional RS-232 Port

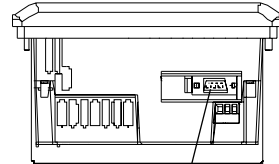

10

RS-232 (DH-485) with additional RS-232 Port

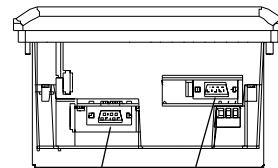

17 10

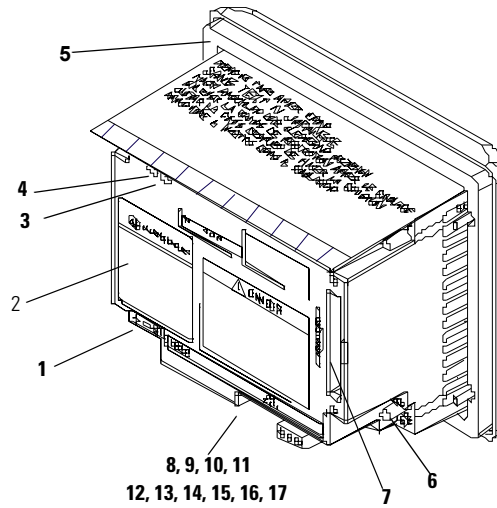

#	Feature	Description
1	Power Connection Terminals	Connects to external power source.
2	Nameplate Label	Provides product information.
3	Fault Status (Red)	Indicates firmware or hardware faults.
4	COMM Status (Green)	Indicates when communication is occurring.
5	Sealing Gasket	Seals the front of the terminal to an enclosure or panel.
6	Reset Button	Resets the terminal.
7	Memory Card Slot	Accepts a memory card which stores applications.
8	DH-485 Communication Port	Connects to an SLC or MicroLogix controller, DH-485 network, or Wallmount Power Supply (Cat. No. 1747-NP1).
9	DH-485 Programming Connector	Connects to a Personal Computer Interface Converter (Cat. No. 1747-PIC) for transferring applications. Also connects to an SLC programmer, such as the Hand-held Terminal (Cat. No. 1747-PT1).
10	RS-232 (DH-485) Communication Port	Connects to the Channel 0 port of an SLC 5/03, 5/04, or 5/05 for point-to-point DH-485 communication. Connects to a MicroLogix controller through an AIC+ Link Coupler. Also connects to the RS-232 serial port of a computer for transferring applications.
11	Remote I/O Port	Connects to a scanner or sub-scanner on a remote I/O network.
12	DH+ Communication Port	Connects to a PLC-5, SLC 5/04, or ControlLogix controller on a DH+ link.
13	DeviceNet Connector	Connects to a DeviceNet network.
14	ControlNet Connector	Connects to a ControlLogix controller (with 1756-CNB module) or PLC-5 on a ControlNet network.
15	RS-232 (DF1) Communication Port	Connects to a PLC, SLC, or MicroLogix controller with a DF1 port.
16	Ethernet Connector	Connects to a PLC-5E or SLC 5/05 controller, or a ControlLogix, MicroLogix, FlexLogix, or CompactLogix (with appropriate bridge module) on an EtherNet/IP network.
17	RS-232 Printer/File Transfer Port	Connects to a printer. On remote I/O, DH+, DF1, DeviceNet, EtherNet/IP, or ControlNet terminals, this port also connects to the RS-232 port of a computer for transferring applications. The RS-232 port on the DH-485 or RS-232 (DH-485) terminal is used to connect a printer but not for file transfers.

PanelView 900/1000 Terminal Features

This section defines features of the PanelView 900 and 1000 terminals.

IMPORTANT

PanelView 900 terminals are no longer available. Contact your local sales office or authorized Rockwell Automation Distributor for suitable substitutes.

PanelView 900/1000 Terminal Features (front)

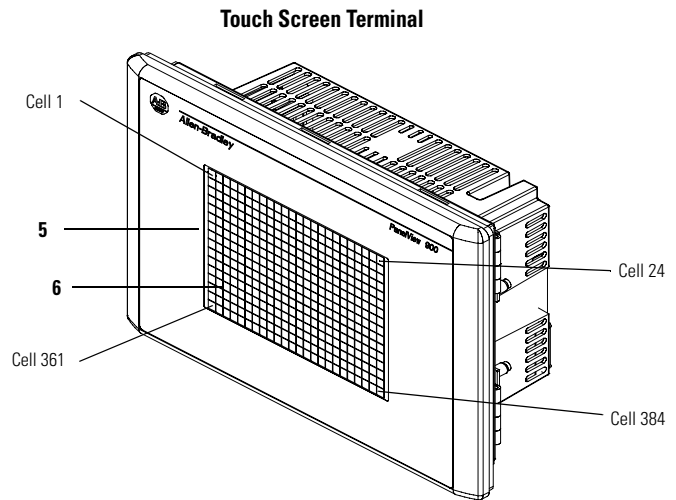
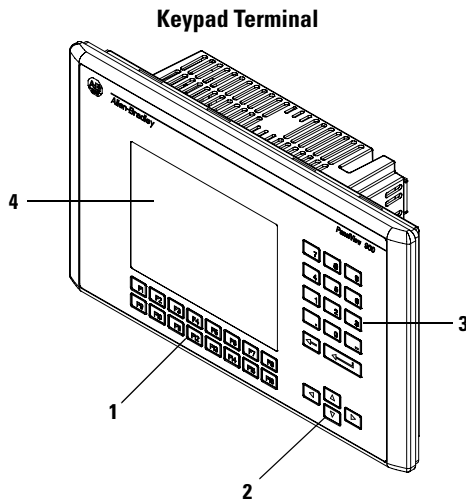

#	Feature	Description
1	Function Keys (F1...F16)	Use the function keys on keypad terminals to initiate functions on the terminal display. These keys may have custom legends.
2	Cursor Keys	Use the cursor keys to move the cursor in displayed lists, to select a numeric entry object or to enter configuration mode.
3	Numeric Entry Keys	<p>0...9 - Enters numeric values.</p> <p>. Enters a decimal point.</p> <p>- Enters a negative value.</p> <p>← Clears entered digits or cancels the scratchpad.</p> <p>↵ Stores an entered value.</p>
4	Keypad Terminal Display	On keypad terminals, initiate the function of a displayed object, such as an ON or OFF push button, by pressing a function key (F1...F16).
5	Touch Screen Terminal Display	On touch screen terminals, initiate the function of a displayed object, such as an ON or OFF push button, by touching the screen object. Each interactive screen object occupies one or more of 384 cells.
6	Touch Cells (Touch Screen terminal)	The 384 touch cells (24 columns x 16 rows) let you initiate functions by touching the screen. Interactive screen objects are aligned with touch cells when the application is created.

PanelView 900/1000 Terminal Features (back)

Remote I/O, DF1, DH+, DeviceNet, Ethernet, or ControlNet with additional RS-232 Port

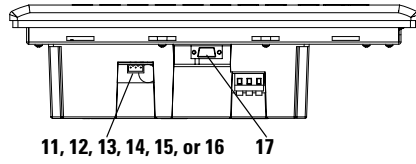

DH-485 Version without additional RS-232 Port

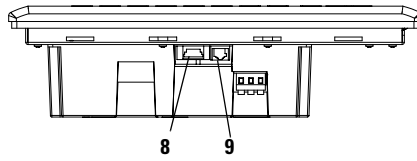

DH-485 with additional RS-232 Port

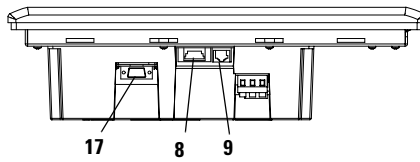

RS-232 (DH-485) without additional RS-232 Port

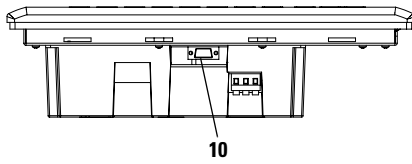

RS-232 (DH-485) with additional RS-232 Port

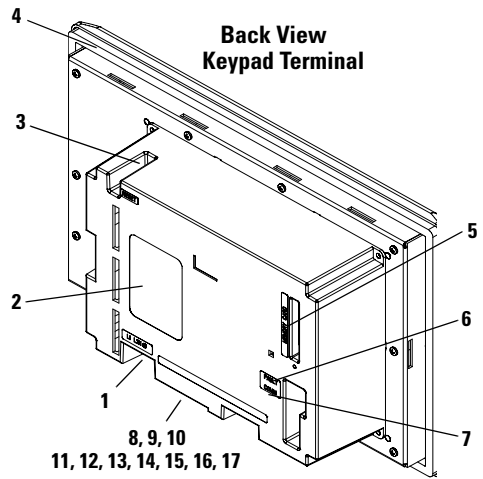
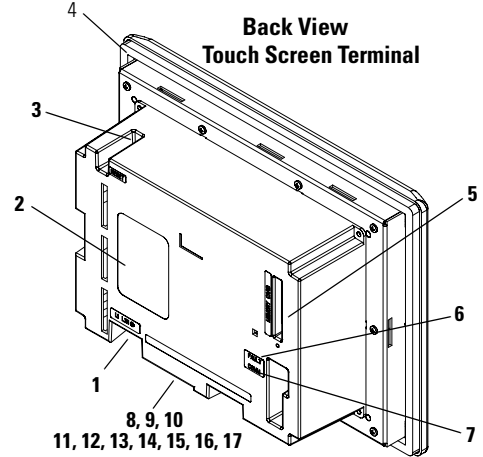
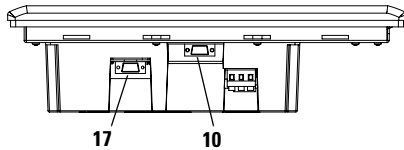

#	Feature	Description
1	Power Connection Terminals	Connects to external power source.
2	Nameplate Label	Provides product information.
3	Reset Button	Resets the terminal.
4	Sealing Gasket	Seals the front of the terminal to an enclosure or panel.
5	Memory Card Slot	Accepts a memory card which stores applications.
6	FAULT Status (Red) Indicator	Indicates firmware or hardware faults.
7	COMM Status (Green) Indicator	Indicates when communication is occurring.
8	DH-485 Communication Port	Connects to an SLC or MicroLogix controller, DH-485 network, or Wallmount Power Supply (Cat. No. 1747-NP1).
9	DH-485 Programming Connector	Connects to a Personal Computer Interface Converter (Cat. No. 1747-PIC) for transferring applications. Also connects to an SLC programmer, such as the Hand-held Terminal (Cat. No. 1747-PT1).
10	RS-232 (DH-485) Communication Port	Connects to the Channel 0 port of an SLC 5/03, 5/04, or 5/05 for point-to-point DH-485 communication. Connects to a MicroLogix controller through an AIC+ Link Coupler. Also connects to the RS-232 serial port of a computer for transferring applications.
11	Remote I/O Port	Connects to a scanner or sub-scanner on a remote I/O network.
12	DH+ Communication Port	Connects to a PLC-5, SLC 5/04, or ControlLogix controller on a DH+ link.
13	DeviceNet Connector	Connects to a DeviceNet network.
14	ControlNet Connector	Connects to a ControlLogix controller (with 1756-CNB module) or PLC-5 on a ControlNet network.
15	RS-232 (DF1) Communication Port	Connects to a PLC, SLC, or MicroLogix controller with a DF1 port.
16	Ethernet Connector	Connects to a PLC-5E or SLC 5/05 controller, or a ControlLogix, MicroLogix, FlexLogix, or CompactLogix (with appropriate bridge module) on an EtherNet/IP network.
17	RS-232 Printer/File Transfer Port	Connects to a printer. On remote I/O, DH+, DF1, DeviceNet, EtherNet/IP, or ControlNet terminals, this port also connects to the RS-232 port of a computer for transferring applications. The RS-232 port on the DH-485 or RS-232 (DH-485) terminal is used to connect a printer but not for file transfers.

PanelView 1400 Terminal Features

This section defines features of the PanelView 1400 terminals.

IMPORTANT

PanelView 1400 terminals are no longer available. Contact your local sales office or authorized Rockwell Automation Distributor for suitable substitutes.

PanelView 1400 Terminal Features (front)

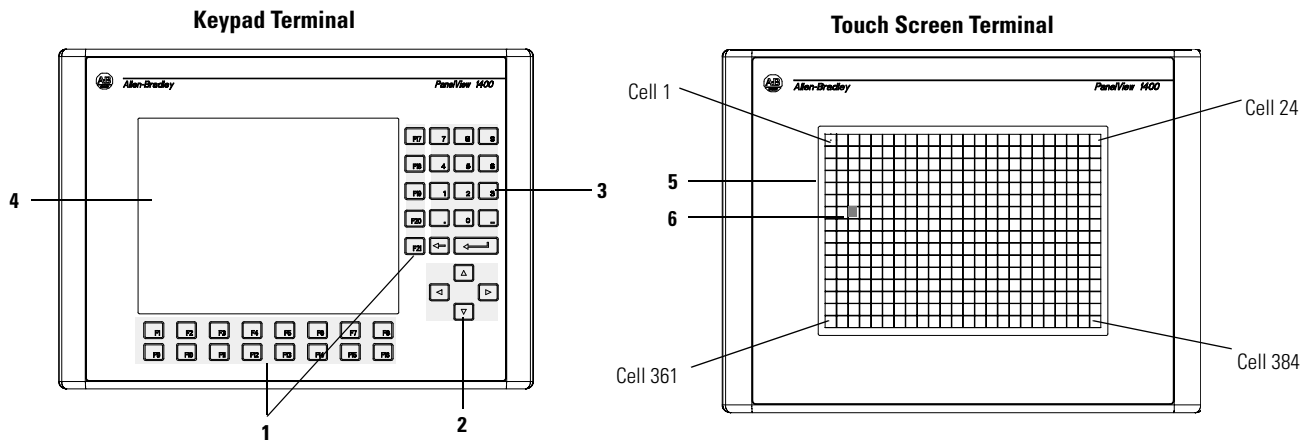

#	Feature	Description
1	Function Keys (F1...F21)	Use the function keys on keypad terminals to initiate functions on the terminal display. These keys may have custom legends.
2	Cursor Keys	Use the cursor keys to move the cursor in displayed lists, to select a numeric entry object, or to enter configuration mode.
3	Numeric Entry Keys	<ul style="list-style-type: none"> 0...9 - Enters numeric values. . - Enters a decimal point. - - Enters a negative value. ← - Clears entered digits or cancels the scratchpad. ↵ - Stores an entered value.
4	Keypad Terminal Display	On keypad terminals, initiate the function of a displayed object, such as an ON or OFF push button, by pressing a function key (F1...F21).
5	Touch Screen Terminal Display	On touch screen terminals, initiate the function of a displayed object, such as an ON or OFF push button, by touching the screen object. Each interactive screen object occupies one or more of 384 cells.
6	Touch Cells (Touch Screen terminal)	The 384 touch cells (24 columns x 16 rows) let you initiate functions by touching the screen. Interactive screen objects are aligned with touch cells when the application is created.

PanelView 1400 Terminal Features (back and sides)

Remote I/O, DF1, DH+, DeviceNet, ControlNet, or Ethernet with additional RS-232 Port

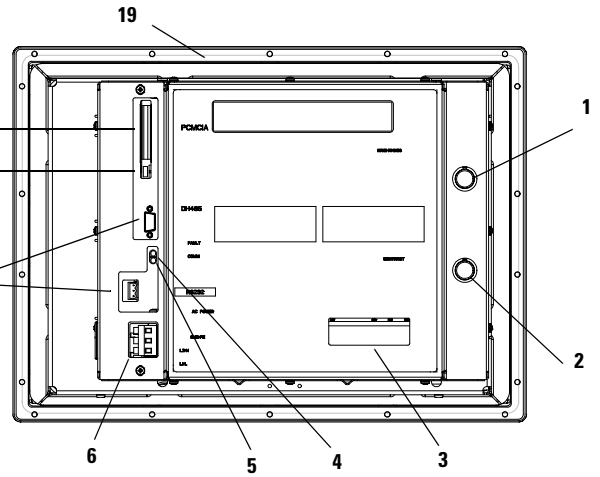
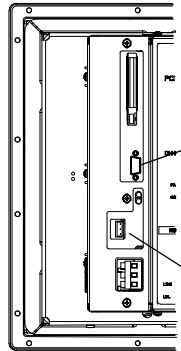

DH-485 with additional RS-232 Port

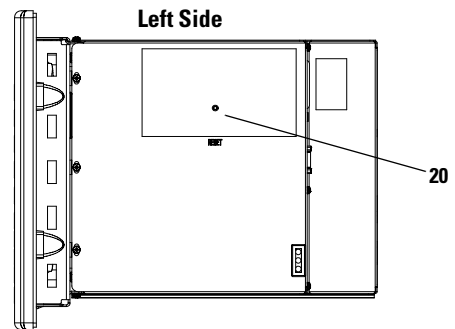
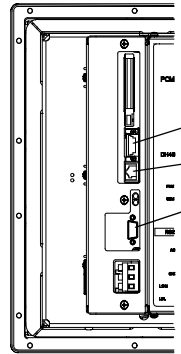

RS-232 (DH-485) with additional RS-232 Port

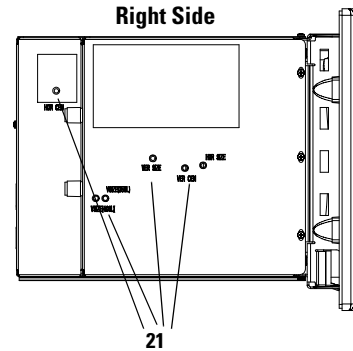
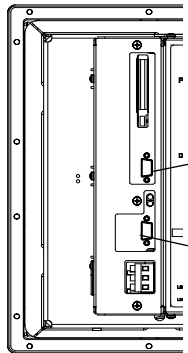

#	Feature	Description
1	Brightness Control	Adjusts the brightness of the color display.
2	Contrast Control	Adjusts the contrast of the color display.
3	Nameplate Label	Provides product information.
4	FAULT Status (Red)	Indicates firmware or hardware faults.
5	COMM Status (Green)	Indicates when communication is occurring.
6	Power Connection Terminals	Connects to external power source.
7	DH-485 Communication Port	Connects to an SLC or MicroLogix controller, DH-485 network, or Wallmount Power Supply (Cat. No. 1747-NP1).
8	DH-485 Programming Connector	Connects to a Personal Computer Interface Converter (Cat. No. 1747-PIC) for transferring applications. Also connects to an SLC programmer, such as the Hand-held Terminal (Cat. No. 1747-PT1).
9	RS-232 (DH-485) Communication Port	Connects to the Channel 0 port of an SLC 5/03, 5/04, or 5/05 for point-to-point DH-485 communication. Connects to a MicroLogix controller through an AIC+ Link Coupler. Also connects to the RS-232 serial port of a computer for transferring applications.
10	Remote I/O Port	Connects to a scanner or sub-scanner on a remote I/O network.
11	DH+ Communication Port	Connects to a PLC-5, SLC 5/04, or ControlLogix controller on a DH+ link.
12	DeviceNet Connector	Connects to a DeviceNet network.
13	ControlNet Connector	Connects to a ControlLogix controller (with 1756-CNB module) or PLC-5 on a ControlNet network.
14	RS-232 (DF1) Communication Port	Connects to a PLC, SLC or MicroLogix controller with a DF1 port.
15	Ethernet Connector	Connects to a PLC-5E or SLC 5/05 controller, or a ControlLogix, MicroLogix, FlexLogix, or CompactLogix (with appropriate bridge module) on an EtherNet/IP network.
16	RS-232 Printer/File Transfer Port	Connects to a printer. On remote I/O, DH+, DF1, DeviceNet, EtherNet/IP, or ControlNet terminals, this port also connects to the RS-232 port of a computer for transferring applications. The RS-232 port on the DH-485 or RS-232 (DH-485) terminal is used to connect a printer but not for file transfers.
17	Memory Card Eject Button	Ejects memory card from slot.
18	Memory Card Slot	Accepts a memory card which stores applications.
19	Sealing Gasket	Seals the front of the terminal to an enclosure or panel.
20	Reset Button	Resets the terminal.
21	CRT Board Adjustments	See the warning below.

ATTENTION

Only qualified service technicians should access the CRT board adjustments. Failure to follow this caution could result in electrical shock, a misadjusted monitor, or a damaged monitor.

Applications

PanelView terminals operate with custom designed applications. The first time you power on the terminal, (no application file loaded), the terminal displays the Configuration Mode menu.

Chapter 3 describes the terminal functions you can configure from this menu.

TIP

Remote I/O terminals provide an out-of-box application for setting remote I/O communication parameters.

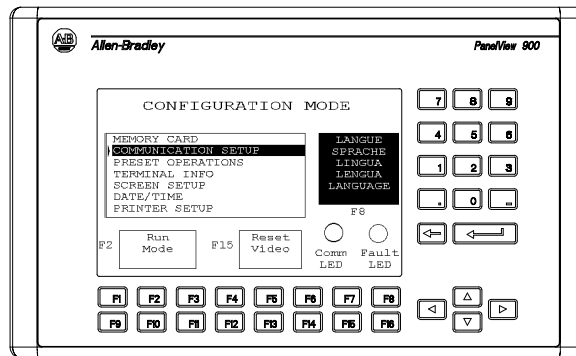

If an application is loaded, the terminal displays the application's start-up screen.

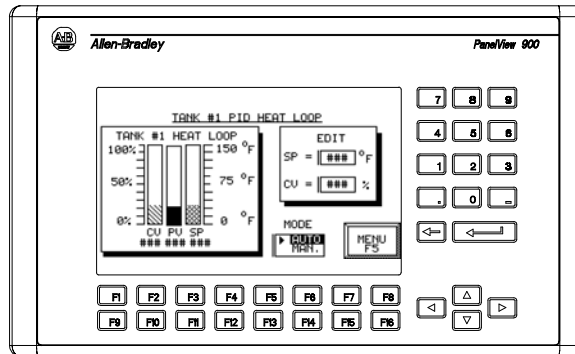

TIP

The application designer is responsible for documenting the operation of the application and selecting a startup screen.

How the terminal operates depends on the application and the type of terminal (touch screen or keypad).

Touch Screen Operation

Applications for touch screen terminals are controlled by touching screen objects.

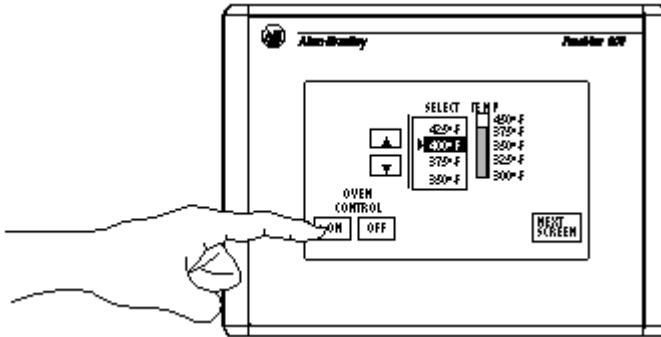

Keypad Operation

Applications for keypad terminals are controlled by pressing function keys that correspond to screen objects. Data is entered manually by using the numeric entry keys.

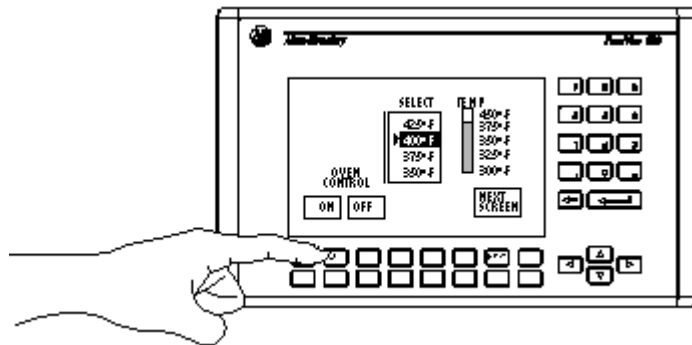

A function key legend kit is available for each terminal (except the PV300 Micro terminal) to create custom labels for the function keys.

See the accessories at the end of this chapter.

ATTENTION



Do not press multiple touch screen objects or multiple function keys at the same time. This may result in unintended operation.

IMPORTANT

The keypad is designed for finger or gloved finger operation. The touch screen may be operated with a finger, gloved finger, or with a touch screen plastic stylus device with a minimum tip radius of 1 mm (0.040 in) to prevent damage to the touch screen. Using any other object or tool may damage the keypad or touch screen.

Configuration Mode Menu

You can configure terminal functions from the Configuration Mode menu. These functions include how to:

- select a language.
- upload/download applications with a memory card.
- set or display serial communication parameters.
- select preset values.
- obtain terminal and application information.
- adjust screen parameters.
- set time and date.
- set printer parameters (for terminals with an RS-232 printer port).
- return to run mode.

[Chapter 3](#) describes how to enter configuration mode and operations you can perform by using the Configuration Mode menu.

Terminal Messages

Terminal messages display:

- status of an operation.
- minor faults, errors, or numeric entry mistakes.
- operator prompts.

[Appendix B](#) describes terminal messages and provides a list of recommended actions.

Printing

PanelView terminals equipped with an RS-232 printer port can print:

- triggered messages in a message display.
- triggered states of a multistate indicator.
- alarm messages.
- alarm lists.

Print attributes for objects are defined in the application.

Any printer that supports the IBM enhanced character set can be connected to the RS-232 printer port of a PanelView terminal.

Alarm List

PanelView terminals support an Alarm List queue to store information on triggered alarms. The Alarm List stores a maximum of 100 alarms or as many as the terminal can hold in nonvolatile RAM. The number of alarms stored in the list is configured by using the PanelBuilder32 software.

The Alarm List stores the following data for each alarm:

- Acknowledge indicator
- Alarm date and time
- Acknowledge date and time
- Alarm trigger value
- Alarm text including variables

The Alarm List is cleared:

- when an application is downloaded to the terminal.
- when the terminal is reset or power is cycled.

The Alarm List object may appear on the Alarm Banner or other application screens. The data that displays in the Alarm List is configured using the PanelBuilder32 software.

Accessories

This section lists the accessories available for the PanelView terminals.

Software

Cat. No.	300M	300	550	600	900	1000	1400	Description
2711-ND3	x	x	x	x	x	x	x	Windows software required for creating PanelView applications on a personal computer.

Function Key Legend Kits

Cat. No.	300	550	600	900	1000	1400	Description
2711-NF1		x					5 legend inserts with key labels F1...F10 on one side. Use blank side to create custom labels.
2711-NF2A				x			1 legend insert for PV900 keypad (monochrome) terminal with key labels F1...F16 on one side. Use blank side to create custom labels.
2711-NF2C				x			1 legend insert for PV900 keypad (color) terminal with key labels F1...F16 on one side. Use blank side to create custom labels.
2711-NF4			x				1 legend insert with key labels F1...F10 on one side. Use blank side to create custom labels.
2711-NF5						x	2 legend inserts. One has key labels F1...F16; the other has key labels F17...F21. Use blank sides to create custom labels.
2711-NF6					x		1 legend insert with key labels F1...F16. Use blank side to create custom labels.
2711-NF7	x						2 legend inserts with key labels F1...F4 and F5...F8. Use blank side to create custom labels.

Memory Cards and Retainer

Cat. No.	300	550	600	900	1000	1400	Description
2711-NM11 ⁽¹⁾	x	x	x	x	x	x	256K memory card for storing applications.
2711-NM13	x	x	x	x	x	x	2M flash memory card for storing applications.
2711-NM14	x	x	x	x	x	x	4M flash memory card for storing applications.
2711-NM15	x	x	x	x	x	x	10M flash memory card for storing applications.
2711-NM216 ⁽¹⁾	x	x	x	x	x	x	16M flash ATA card for storing applications and font files.
2711-NM232	x	x	x	x	x	x	32M flash ATA card for storing applications and font files.
2711-NMCC		x	x	x	x		Secures memory card in the PanelView 500/600 keypad or the PanelView 900/1000 keypad and touch screen. Prevents electrostatic discharge.
2711-NMCD		x					Secures memory card in 550 touch screen terminal and prevents electrostatic discharge.
2711-NMCE	x		x				Secures memory card in PanelView 300 keypad and 600 touch screen terminals and prevents electrostatic discharge.

⁽¹⁾ Contact Rockwell Automation for availability.

Antiglare Overlay

Self-adhesive filters minimize the reflection of terminal displays.

Cat. No.	300M	300	550	600	900	1000	1400
2711-NV4 (Keypad)			x				
2711-NV4T (Touch Screen Terminals)			x	x			
2711-NV3K (Keypad)					x		
2711-NV3T (Touch Screen Terminals)					x		
2711-NV5 (Keypad)				x			
2711-NV7K (Keypad Terminals)							x
2711-NV7T (Touch Screen Terminals)							x
2711-NV6K (Keypad Terminals)						x	
2711-NV6T (Touch Screen Terminals)						x	
2711-NV8 (Keypad Terminals)		x					

DH-485 Operating and Programming Cables

Cat. No.	Description
1747-PIC	Personal Computer Interface Converter converts RS-232 signals to/from RS-485 signals. Use to transfer applications between a DH-485 terminal and a computer.
1747-C10	1.83 m (6 ft) cable connects a DH-485 terminal to an SLC or DH-485 network.
1747-C11	0.30 m (1 ft) cable connects a DH-485 terminal to an SLC or DH-485 network.
1747-C20	6.1 m (20 ft) cable connects a DH-485 terminal to an SLC or DH-485 network.
1747-CP3	45 cm (17.7 in.) cable connects an RS-232 terminal to an AIC+ (Port1) through a null modem adapter.
1761-CBL-AP00	45 cm (17.7 in.) cable connects an RS-232 terminal to an AIC+ (Port2) through a null modem adapter.
1761-CBL-AC00	3 m (9.8 ft) cable connects an RS-232 terminal to an AIC+ (Port1) through a null modem adapter.
1761-CBL-AS03	3 m (9.8 ft) cable connects a DH-485 terminal to an AIC+ (Port3).
1761-CBL-AS09	9.9 m (29.5 ft) cable connects a DH-485 terminal to an AIC+ (Port3).
1761-CBL-AM00	45 cm (17.7 in.) cable with 2 mini DIN, right angle connectors.
1761-CBL-HM02	2 m (6.5 ft) cable with 2 mini DIN, right angle connectors.
2711-CBL-HM05	5 m runtime cable with 2 mini DIN, right angle connectors.
2711-CBL-HM10	10 m runtime cable with 2 mini DIN, right angle connectors.
1761-CBL-PM00	45 cm (17.7 in.) cable connects an RS-232 terminal to an AIC+ (Port2) through a null modem adapter.

Cat. No.	Description
1761-CBL-PM02	2 m (6.5 ft) cable connects an RS-232 terminal to an AIC+ (Port2) through a null modem adapter.
2711-CBL-PM05	5 m programming cable with a D-shell and mini DIN connector.
2711-CBL-PM10	10 m programming cable with a D-shell and mini DIN connector.

PanelView File Transfer Utility

Cat. No.	Description
2711-ND7	Transfers .PVA files between a PanelView terminal and a computer running Windows.

Power Supply and Link Couplers

The following items are available for all PanelView terminals.

Cat. No.	Description
1747-NP1	Wallmount power supply provides power for DH-485 communication when an SLC controller or network is not connected.
1747-AIC	AIC Link Coupler links devices on a DH-485 network.
1761-NET-AIC	AIC+ Advanced Interface Converter links devices on a DH-485 network including MicroLogix.
1761-NET-DNI	DeviceNet Interface links DF1 PanelViews on a DeviceNet network.
1761-NET-ENI	Ethernet Interface links DF1 or Ethernet devices on an EtherNet/IP network.

RS-232 Cables

Cat. No.	Description
2711-NC13	5 m (15 ft) connects an RS-232 terminal to the Channel 0 port of an SLC 5/03 controller or the RS-232 port of a computer or printer.
2711-NC14	10 m (32 ft) cable connects an RS-232 terminal to the Channel 0 port of an SLC 5/03 controller or the RS-232 port of a computer or printer.
2711-NC21	5 m (15 ft) connects an RS-232 terminal to a MicroLogix controller (except PV300 Micro).
2711-NC22	15 m (49 ft) cable connects an RS-232 terminal to a MicroLogix controller (except PV300 Micro).
2706-NC13	3 m (10 ft) cable connects an RS-232 terminal to an SLC 5/03 controller or the RS-232 port of a computer or printer.
1761-CBL-AP00	0.5 m (1.5 ft) cable connects a PanelView 300 Micro RS-232 terminal to an SLC or PLC.
1761-CBL-PM02	2 m (6.5 ft) cable connects a PanelView 300 Micro RS-232 terminal to an SLC or PLC.
2711-CBL-PM05	5 m (15 ft) cable connects a PanelView 300 Micro RS-232 terminal to a ControlLogix, AIC+, SLC controller, or computer RS-232 port.
2711-CBL-PM10	10 m (30 ft) cable connects a PanelView 300 Micro RS-232 terminal to a ControlLogix, AIC+, SLC controller, or computer RS-232 port.
1761-CBL-AM00	0.5 m (1.5 ft) cable connects a PanelView 300 Micro RS-232 terminal to a MicroLogix.
1761-CBL-HM02	2 m (6.5 ft) cable connects a PanelView 300 Micro RS-232 terminal to a MicroLogix.
2711-CBL-HM05	5 m (15 ft) cable connects a PanelView 300 Micro RS-232 terminal to a MicroLogix 1000/1200/1500, DeviceNet DNI, or AIC+ module.
2711-CBL-HM10	10 m (30 ft) cable connects a PanelView 300 Micro RS-232 terminal to a MicroLogix 1000/1200/1500, DeviceNet DNI, or AIC+ module.

Remote I/O or DH+ Cable

Cat. No.	Description
1770-CD	Shielded, 3-conductor cable (Belden 9463) for connecting a remote I/O terminal to a remote I/O network.

Replacement Parts

This section lists the replacement parts available for the PanelView terminals.

Backlight Lamps

Cat. No.	550	600	900	1000	Description
2711-NL1	x				Halogen backlight lamp for all PV550 terminals. Provides backlighting for LCD display.
2711-NL2			x		Backlight for PV900 color terminal.
2711-NL3		x			Backlight for PV600 color terminal.
2711-NL4				x	Backlight for PV1000 color terminal.
2711-NL5		x			Backlight for PV 600 (Series C only)
2711-NL6				x	Backlight for PV1000 color terminal (Series B only)
2711-NL7				x	Backlight for PV1000 color terminal (Series C only)
2711-NL9				x	Backlight for PV1000 color terminal (Series D and Series E only) Backlight for PV1000 grayscale terminal (Series C and Series D only)
2711-NL10				x	Backlight for PV1000 color terminal (Series F only) Backlight for PV1000 grayscale terminal (Series E only)

Real Time Clock Modules

Cat. No.	300	550	600	900	1000	1400	Description
2711-NB2		x					Real time clock module for PV550 (Series D or earlier). Does not apply to the PV550 touch screen terminals. Contains lithium battery.
2711-NB3		x	x	x	x	x	Real time clock module for PV600, PV900, PV1000, PV1400 or PV550 (Series E and F). Does not apply to PV550/PV600 touch screen terminals. Contains lithium battery.
2711-NB4	x	x	x		x		Real time clock module for PV300, PV550 (Series G and later), PV550/PV600 touch screen, PV600 (Series C and later), PV1000 color (Series D and later), and PV1000 grayscale (Series B and later) terminals. Contains lithium battery.

Panel Mount Clips and Studs

Cat. No.	600	900	1000	1400	Description
2711-NP1				x	10 panel mount clips for PV1400 terminal.
2711-NP2	x	x	x		6 panel mount clips for PV600, PV900 or PV1000 terminals.
2711-NP3				x	Optional panel mount studs (18) for PV1400 terminals.

Remote I/O Connector

Cat. No.	550	600	900	1000	1400	Description
22112-046-03	x	x	x	x	x	Terminal block connector plugs into remote I/O port of remote I/O terminals.

Power Input Connector

Cat. No.	300M	600 (touch only)	Description
2711-TBDC	x	x	Removable dc power input connectors for PanelView 300 Micro (qty. of 10).

Applying Power and Resetting Terminal

Chapter Objectives

This chapter provides information on:

- wiring and safety guidelines.
- connecting AC or DC power.
- resetting the terminal.
- power-up sequence.

Wiring and Safety Guidelines

Use publication NFPA 70E, Electrical Safety Requirements for Employee Workplaces when wiring the PanelView terminals. In addition to the NFPA general guidelines:

- connect the terminal to its own branch circuit.
- the input power should be protected by a fuse or circuit breaker rated at no more than 15 Amps.
- route incoming power to the PanelView terminal by a separate path from the communication cable.

IMPORTANT

Do not run signal wiring and power wiring in the same conduit.

- where power and communication lines must cross, they should cross at right angles. Communication lines can be installed in the same conduit as low level DC I/O lines (less than 10V).

Hazardous Location Considerations

This equipment is suitable for use in Class I, Division 2, Groups A, B, C, D; Class II, Division 2, Groups F and G; Class III; or non-hazardous locations only. The following WARNING statement applies to use in hazardous locations.

WARNING**EXPLOSION HAZARD**

- Substitution of components may impair suitability for Class I, Class II, Class III Division 2.
- Do not replace components or disconnect equipment unless power has been switched off or the area is known to be non-hazardous.
- Do not connect or disconnect components unless power has been switched off or the area is known to be non-hazardous.
- This product must be installed in an enclosure. All cables connected to the product must remain in the enclosure or be protected by conduit or other means.
- All wiring must comply with N.E.C. article 501-4(b), 502-4(b), 503-3(b) as appropriate.

See the nameplate on terminal for hazardous locations certifications.

ATTENTION

In Class I, Class II, Class III Division 2 Hazardous locations, the PanelView terminal must be wired per the National Electric Code as it applies to hazardous locations. Peripheral equipment must also be suitable for the location in which it is installed.

Connect AC Power

Below are AC electrical ratings for the PanelView terminals. The PV550/PV600 touch screen only terminal is available only with DC power, not AC power.

Terminal Type	Supply Voltage	Power Consumption, Max
PV550	85...264V AC, 47...63 Hz	45 VA
PV600	85...264V AC, 43...63 Hz	60 VA
PV900M/PV900C	85...264V AC, 47...63 Hz	110 VA
PV1000G/PV1000C	85...264V AC, 47...63 Hz	55 VA
PV1400	85...264V AC, 43...63 Hz	200 VA

ATTENTION



Do not apply power to the PanelView terminal until all wiring connections have been made. Failure to do so may result in electrical shock.

The PanelView terminals are IEC 1131-2 Equipment Class I devices and require you to connect the GND (Ground) or \oplus (Protective Earth) terminal to an earth conductor.

IMPORTANT

The PanelView terminals are designed for safe use when installed in a NEMA Type 12, 13, 4X (indoor use only), IP54 or IP65 rated enclosure.

Follow these steps to connect power to the AC versions of the PanelView.

1. Secure AC power wires to the L1 and L2N terminal block screws.
2. Secure the Earth Ground/Protective Earth wire to the GND or the \oplus screw on the terminal block.

ATTENTION



Improper wiring of the power terminals may result in voltage at the communication connector shells.

See the appropriate wiring diagram on [page 62](#).

3. Apply power to the terminal.

PanelView 550 Terminal

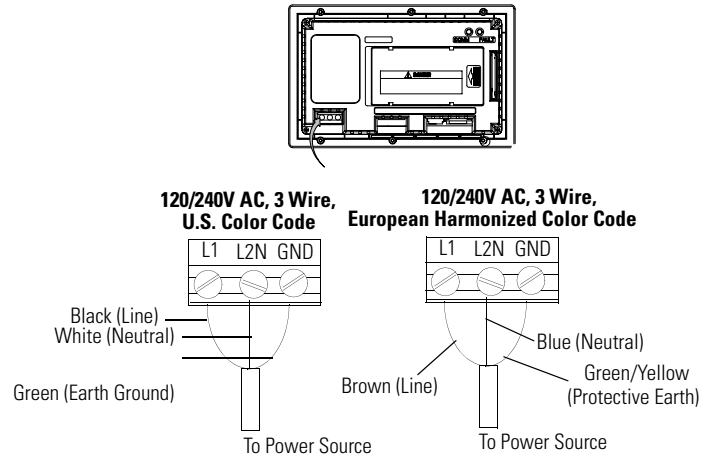

PanelView 900/1000 Terminal

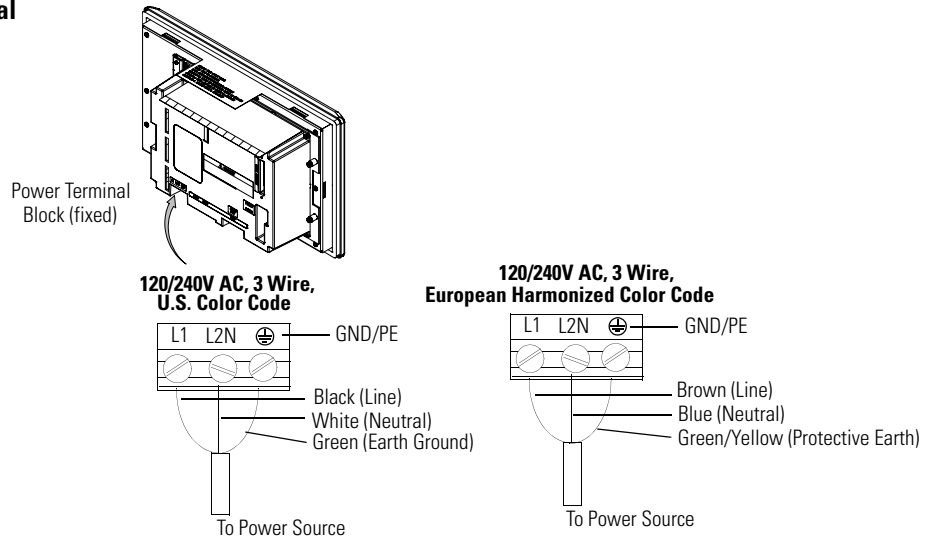

PanelView 1400 Terminal

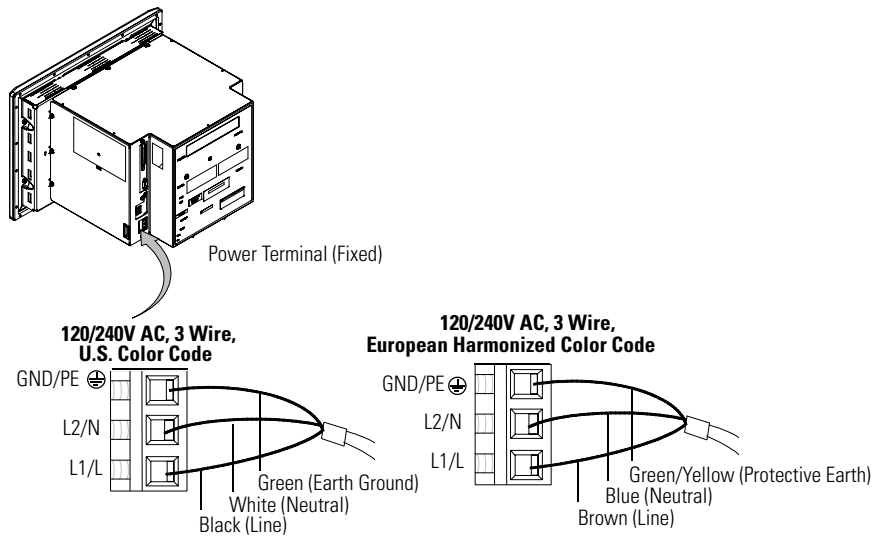

Connect DC Power

The L1 versions (Cat. No. 2711-K5 A5 A18...32V1L1, 2711-T9C1L1) of the PV300, PV300 Micro, PV550, PV600, PV900, and PV1000 terminals connect to a 24V DC power source.

The table below shows the electrical ratings for the DC versions of the terminals. Electronic circuitry and an internal fuse protect the terminals from reverse polarity and over-voltage conditions.

Terminal Type	Supply Voltage (24V DC nominal)	Power Consumption, Max
PV300 Micro	11...30V DC	2.5 W (0.105 A @ 24V DC)
PV300	18...32V DC	6 W (0.25 A @ 24V DC)
PV550	18...30V DC	18 W (0.75 A @ 24V DC)
PV550 (touch only)	18...32V DC	18 W (0.75 A @ 24V DC)
PV600	18...32V DC	24 W (1.0 A @ 24V DC)
PV600 (touch only)	18...32V DC	24 W (1.0 A @ 24V DC)
PV900M	18...30V DC	58 W (2.5 A @ 24V DC)
PV900C	18...32V DC	50 W (2.1 A @ 24V DC)
PV1000G	18...32V DC	24 W (1.0 A @ 24V DC)
PV1000C	18...32V DC	24 W (1.0 A @ 24V DC)

ATTENTION



Do not connect a DC rated PanelView terminal to an AC power source. Connecting to an AC power source may damage the terminal.

IMPORTANT

The PanelView terminals are designed for use when installed in a NEMA Type 12, 13, NEMA 4X (indoor use only), IP54 or IP65 rated enclosure.

ATTENTION



Do not power PanelView terminals from the I/O power on a controller or from DeviceNet network power. If you try to do this, the PanelView will not power up and the DeviceNet or controller power supply may be over-stressed.

ATTENTION



Use only a safety extra-low voltage (SELV) power supply as a source for the PanelView 300 Micro, PanelView 300 or 550 touch screen terminal. A SELV power supply does not exceed 42.4V DC.

Connect the power source to the terminal at the 3-screw terminal block (PV300 Micro removable and PV600 Touch only, all others fixed).

WARNING



Explosion Hazard

- Substitution of components may impair suitability for Class I, Class II, Class III, Division 2.
 - Do not replace components or disconnect equipment unless power has been switched off or the area is known to be non-hazardous.
 - Do not connect or disconnect components unless power has been switched off or the area is known to be non-hazardous.
 - This product must be installed in an enclosure. All cables connected to the product must remain in the enclosure or be protected by conduit or other means.
 - All wiring must comply with N.E.C. article 501-4(b).
-

Follow these steps to connect power to the dc versions of the PanelView.

1. Secure the DC power wires to the terminal block screws.

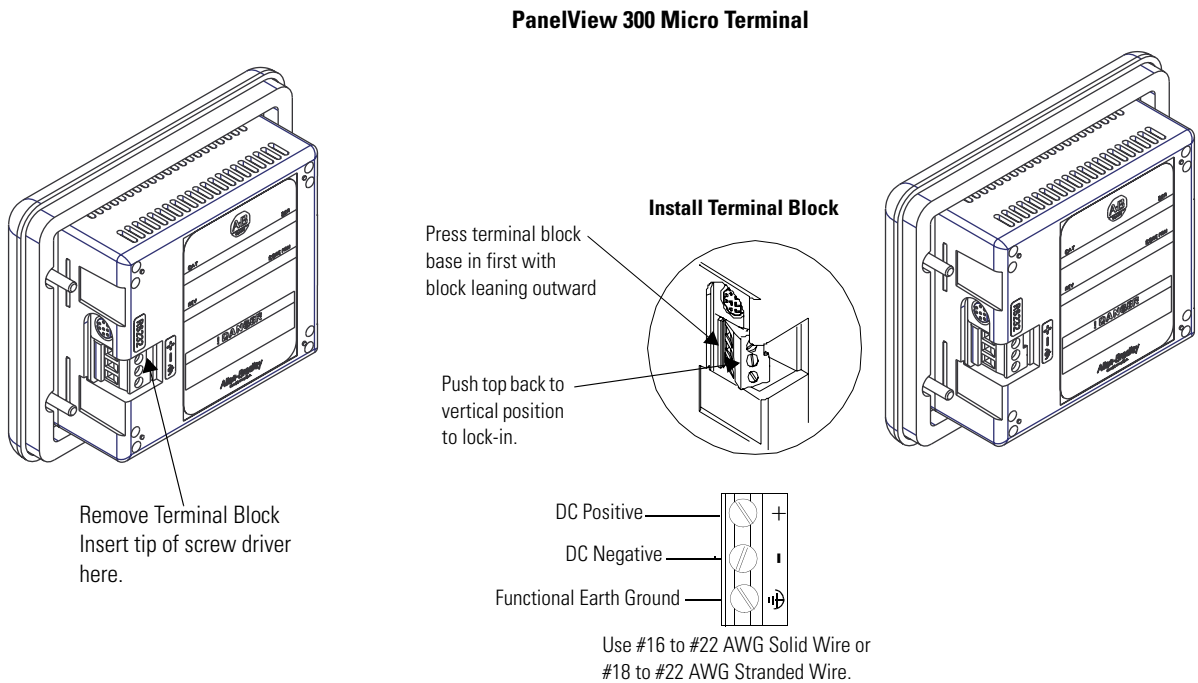
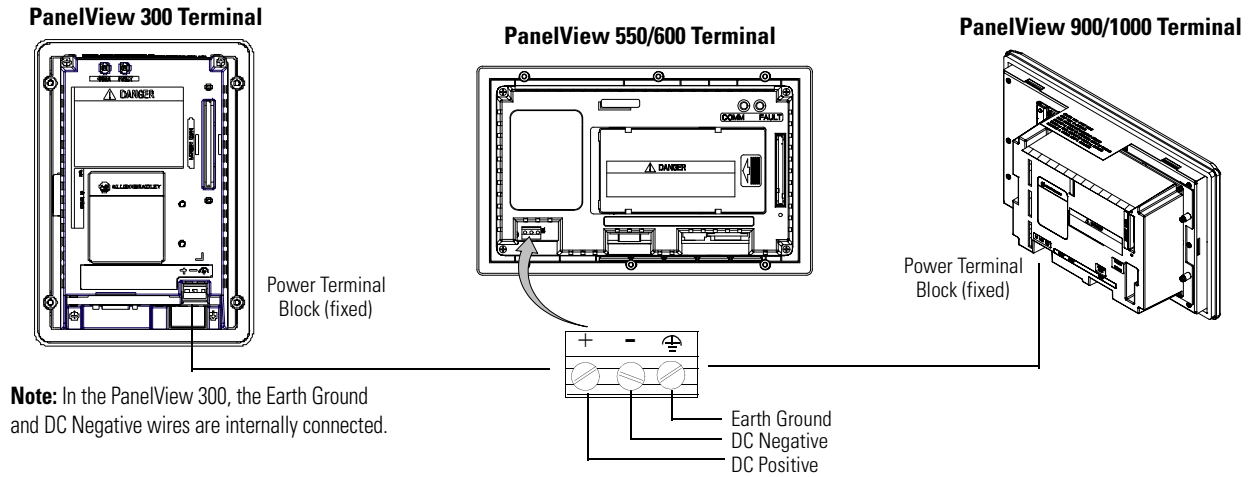

2. Secure the Functional Earth Ground (FE) wire to the correct terminal block screw.

The dc negative and Functional Earth Ground wires are internally connected in the PanelView 300 Micro terminal.

3. Apply 24V DC power to the terminal.

Reset the Terminal

Resetting the terminal re-initializes the PanelView terminal (same as cycling power).

Follow these steps to reset the PV300, PV300 Micro, PV550 (keypad, keypad and touch) or the PV600 (keypad, keypad and touch) terminals.

- Simultaneously press the Left arrow ◀, Right arrow ▶, and Enter ↵ keys. The terminal performs its powerup sequence.

The sequence in which keys are pressed (while running an application), determines what appears after the reset.

- If you press the Left ◀ and Right ▶ arrow keys before the Enter ↵ key, the Configuration Mode menu appears.
- If you press the Enter ↵ key before the arrow keys, the terminal runs the loaded application.

TIP

If the Left ◀ or Right ▶ arrow keys on the PanelView 300 Micro are assigned as function keys, you must use the GoTo Configuration Screen button.

Follow these steps to reset the PV550 and PV600 (touch only)/PV900/PV1000/PV1400 terminals.

1. Use a narrow, non-conductive tool to press the reset button.

The terminal performs its powerup sequence.

ATTENTION



Use a nonconducting object to press the Reset button. Do not use a conducting object such as a paper clip that may damage the terminal. Do not use the tip of a pencil; graphite may damage the terminal. The normally-open, momentarily-closed Reset button is designed for only 1.3 N (0.29 lb) operating force. Use of excessive force may damage the button or cause it to stick.

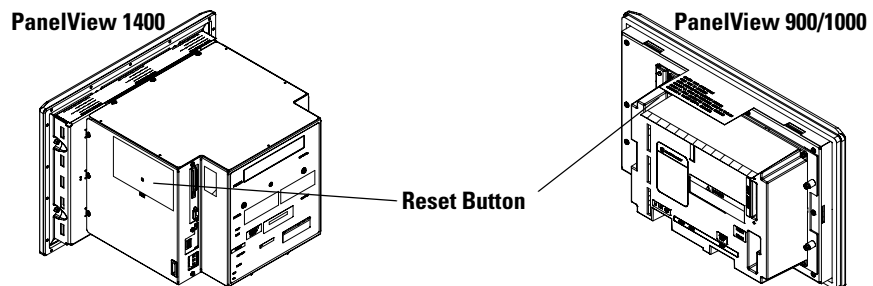

On the PV550/PV600 touch screen terminals, the Reset button is on the right, below the Memory Card slot.

Power-up Sequence

When resetting or applying power to a PanelView terminal, the terminal runs a series of self-tests. The initial display shows copyright information and the status of each self-test number.

See [Appendix B](#) for a description of the self-test numbers.

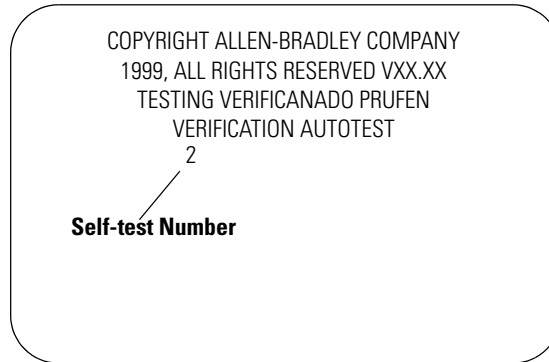

For DH-485 and RS-232 Terminals

- If an application is loaded, the terminal displays either the screen that was present prior to reset or power down, or the startup screen.
- If an application is not loaded, the Configuration Mode menu appears.

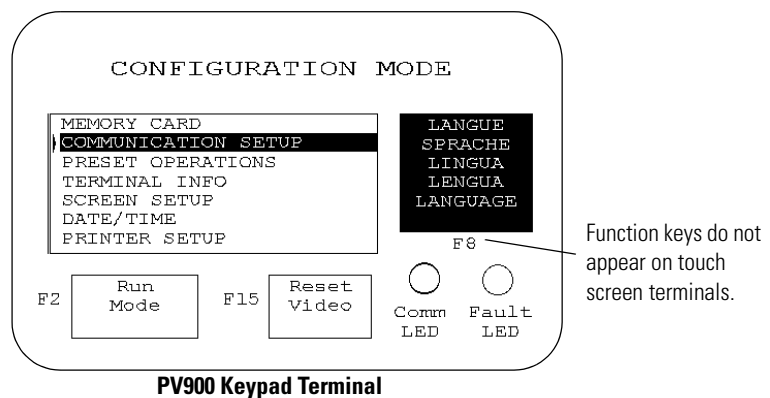

Note: On PV550/600 terminals, the Reset Video is F9.
 On PV300 and PV300 Micro terminals, the Reset Video is F2.

For Remote I/O Terminals

An out-of-box application screen opens allowing you to set remote I/O parameters for the terminal. This screen is only available for initial setup. Once an application is downloaded, the remote I/O setup screen is erased.

The table on the next page defines the remote I/O Parameters.

Remote I/O Setup

Rack #:	<input type="text" value="1"/>	Octal	Rack Size:	<input type="text" value="1/4"/>	F1
Starting Module Group:				<input type="text" value="0,1"/>	F2
Pass-Through Enabled:				<input type="text" value="Yes"/>	F3
Last Chassis:				<input type="text" value="No"/>	F4
Block Transfer Time out:				<input type="text" value="0"/>	F5
Baud Rate:				<input type="text" value="57.6K"/>	F6

PV550 Terminal

Remote I/O Setup

Rack # (Octal):	<input type="text" value="2"/> <input type="text" value="1"/> <input type="text" value="0"/>	F1
Rack Size:	<input type="text" value="1/4"/>	F2
Starting Module Group:	<input type="text" value="0,1"/>	F3
Pass-Through Enabled:	<input type="text" value="Yes"/>	F4
Last Chassis:	<input type="text" value="No"/>	F5
Baud Rate:	<input type="text" value="57.6K"/>	F6

PV900 Keypad Terminal

Press this function key on		To set this RIO parameter	Description	Options
550/600	900/1000/1400			
▶	F1	Rack #	Rack address of terminal on RIO network. On PV550/600: Press ↵ to open the scratchpad. Enter the rack address and press ↵ again. On PV900/PV1000/PV1400: Press F1 to set the rack #, then use the up and down arrow keys to select an address.	0...76
F1	F2	Rack Size	Rack size of terminal. Each key press displays a different size. The terminal occupies a single rack.	1/4, 1/2, 3/4, Full
F2	F3	Starting Module Group	Starting module group number of the terminal in the assigned rack. Each key press displays a different module group.	0,1 2,3 4,5 6,7
F3	F4	Pass-through Enabled	Enables or Disables Pass-through, which lets you transfer applications between a computer on a DH+ link and a terminal on a remote I/O link. A PLC-5 controller passes data between the networks.	Yes or No
F4	F5	Last Chassis	Specifies whether the terminal occupies the last module group in the assigned rack (applies only to PLC2 controllers).	Yes or No
F5		Block Transfer Timeout	Timeout value for block transfers. Each key press toggles a value.	0...60 seconds (0 is the default)
F6	F6	Baud Rate	Communication rate at which the terminal will communicate on the RIO network.	BaudMax. Cable Length 57.6K 10,000 ft 115.2K 5,000 ft 230.4K 2,500 ft

Configuring the Terminal

Chapter Objectives

This chapter shows how to use the Configuration Mode menu to configure terminal settings and perform operations including how to:

- access the Configuration Mode menu.
- select a language.
- use a memory card.
- configure communication (DH485, DH+, remote I/O, ControlNet, DeviceNet, DF1, EtherNet/IP).
- configure presets.
- view terminal information.
- set the time and date.
- adjust display parameters.
- set up the printer.

Application Settings

Configuration parameters are set from the terminal or from the PanelBuilder32 software when creating the application. Settings downloaded with the application have priority over terminal settings if the following option is enabled in the Terminal Setup dialog of the PanelBuilder32 software.

Use Downloaded configuration settings

In addition, the application may allow the controller to change the following while the application is running:

- time and date
- current display screen
- piloted control lists

Access the Configuration Mode Menu

The Configuration Mode menu appears on powerup if an application is not loaded or if the menu was last displayed prior to a reset or power down.

To access Configuration Mode on keypad terminals if an application is running, simultaneously press the Left ◀ and Right ▶ arrow keys on the terminal keypad.

TIP If the Left ◀ or Right ▶ arrow keys on the PanelView 300 Micro are assigned as function keys, you must use the GoTo Config. Screen button.

To access Configuration Mode on touch screen terminals:

- press the GoTo Config. Screen button on application screen or
- press the filled box in the lower right corner of the screen during powerup.

TIP Most of the screens in this chapter are for the PanelView 900 keypad terminal. The screens for other terminals are similar. On keypad terminals you press terminal function keys to modify settings. These keys may differ between terminals depending on the screen size and function key placement. On touch screen terminals, you press the screen field or button.

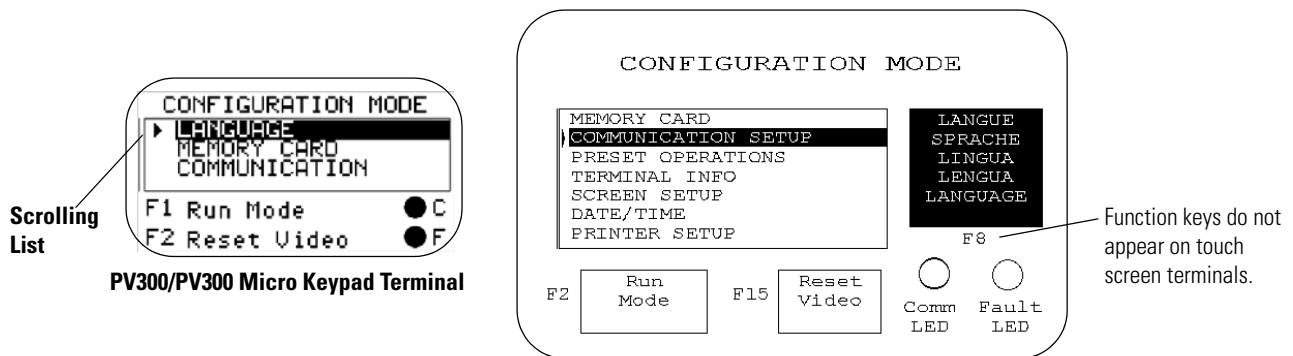

On PV550/600 terminals, the Reset Video button is F9. On PanelView 300, 300 Micro terminals, the Reset Video button is F2.

Operations List

Select an operation using the Up ▲ or Down ▼ arrow keys. Press the Enter ↵ key (keypad terminals) or press  (touch screen terminals) to enter the selection.

Language

Displays the language menu.

Run Mode

Runs the loaded application.

Reset Video

Resets the video to default settings. The reset video function is useful if the screen is set to non-viewable settings.

Comm and Fault Status Indicators

The two status indicators on the Configuration Mode menu indicate the operating state of the terminal. The operating states vary for each communication protocol (and the PV300 Micro terminal).

See [Chapter 13](#).

Select a Language

Press the Language button, [F8] key, from the Configuration Mode menu to display the Language Selection screen.

TIP

On PV300 and PV300 Micro terminals, scroll down on the main configuration menu to select a language.

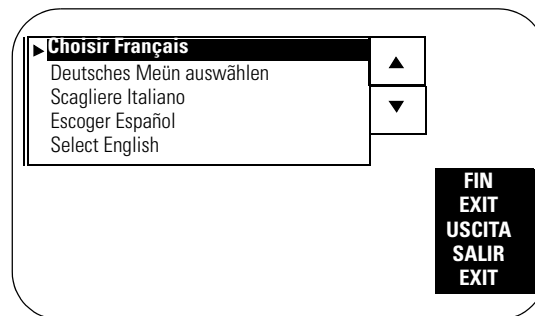

The terminal supports five languages.

- French
- German
- Italian
- Spanish
- English

Language List

Select a language using the up or down arrow keys. All configuration screens and terminal messages will be displayed in the selected language.

Exit

Returns to the Configuration Mode menu.

Use a Memory Card

Select Memory Card from the Configuration Mode menu to transfer applications between a memory card and the terminal. The PanelView 300 Micro does not support a memory card. [Chapter 4](#) describes the transfer procedure.

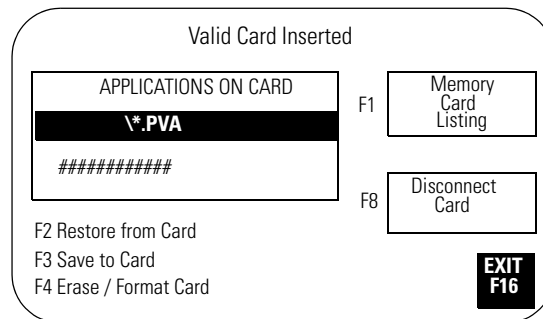

Memory Card Listing

Displays the file names of applications on the memory card. Only 1 file name is displayed at a time. Press the Memory Card Listing button or [F1] to scroll through the file names. This button does not display the names of font files (*.OTF).

Disconnect Card

Closes all files on the memory card. Press Disconnect before removing the card from the slot to ensure all files are closed. A message appears when you can remove the card from the card slot. Failure to follow this procedure could damage the card.

Applications on Card

Displays the selected application file stored on the memory card.

Restore From Card

Transfers the application under Applications on Card to the terminal. Any application in the terminal is overwritten.

Save to Card

Saves the current application in the terminal to the memory card.

Erase/Format Card

Erases and formats a 2711-NM11, -12, -13, -14, 15 memory card. This function deletes all applications on the card. You can't delete individual files. Don't perform this operation on a 2711-NM2xx ATA card or the card will be inoperable.

Exit

Returns to the Configuration Mode menu.

Configure Communication

Select Communication Setup from the Configuration Mode menu to display or change the communication settings for your PanelView terminal. The screen that appears depends on the communication protocol of the terminal.

DH-485 Communication

The DH-485 screen lets you modify or display DH-485 settings for either a DH-485 or RS-232 PanelView terminal. These are the default settings.

- Max Node Address = 31
- Node Address = 2
- Communication Rate = 19200

IMPORTANT

Settings downloaded with a DH-485 application take priority over terminal settings and take effect immediately after the download.

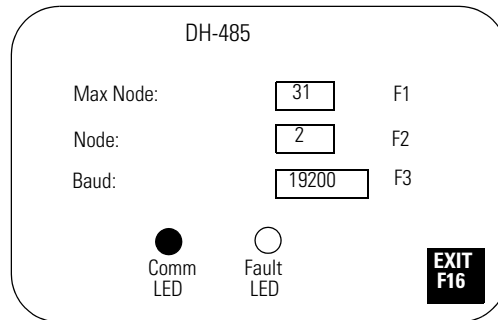

Max Node

Opens the numeric entry scratchpad. Enter the highest node number on the network (up to 31) and press the Enter ↵ key. (On touch screen terminals, press the ↵ key on the scratchpad). A change to the maximum node address takes effect immediately.

Node

Opens the numeric entry scratchpad. Enter the node address of the terminal (0..31) and press the Enter ↵ key. (On touch screen terminals, press the ø key on the scratchpad). If you enter a value greater than the maximum node address, the value is accepted and the maximum node address is updated. A node address change takes effect immediately.

Baud

Steps through the communication rates with each key press: 1200, 2400, 9600, and 19200. The selected communication rate takes effect immediately.

Comm Status Indicator

- solid fill - normal operating state
- blinking - no communication established
- no fill - hardware failure

Fault Status Indicator

- no fill - normal operating state
- blinking - hardware is functioning but an application is not loaded or the current application is corrupted.
- solid fill - hardware failure

DH+ Communication

The DH+ screen lets you display or modify communication settings for the DH+ version of the PanelView terminals.

IMPORTANT

Settings downloaded with a DH+ application take priority over terminal settings and take effect immediately after the download.

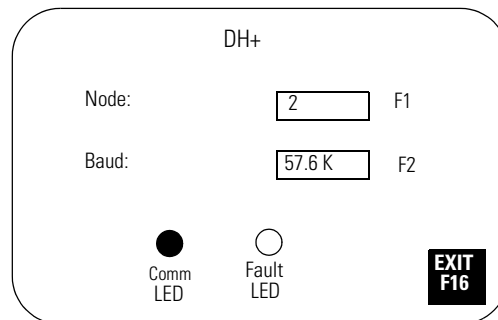

Node

Opens the numeric entry scratchpad. Enter the node address (0...77 octal) of the terminal on the DH+ link and press the Enter ↵ key. (On touch screen terminals, press the Enter key on the scratchpad). A node change takes effect immediately.

Baud

Steps through the communication rates with each key press: 57.6K (default), 115.2K, and 230.4K. The selected rate takes effect immediately. The maximum cable length is restricted at higher communication rates.

Comm Status Indicator

- solid fill - normal operating state
- blinking - no communication established
- no fill - hardware failure

Fault Status Indicator

- no fill - normal operating state
- blinking - hardware is functioning but an application is not loaded or the current application is corrupted.
- solid fill - hardware failure

Exit

Returns to the Configuration Mode menu.

Remote I/O Communication

The remote I/O configuration screen lets you display communication settings for a remote I/O terminal. Remote I/O settings are configured with the out-of-box application provided with the terminal or from the PanelBuilder32 software.

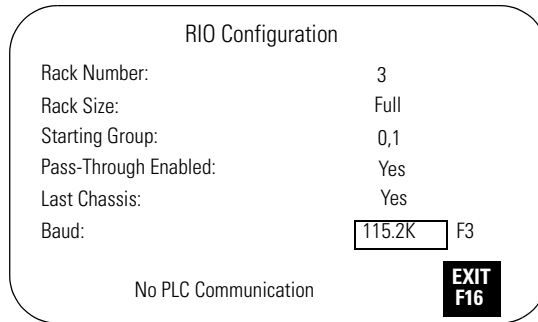

Settings are **read only**, except for communication rate.

Rack Number (read only)

Displays the current rack number (0...76 octal) of the terminal.

Rack Size (read only)

Displays the current rack size (1/4, 1/2, 3/4, or Full) of the terminal.

Starting Group (read only)

Displays the starting module group of the terminal: 0,1 2,3 4,5 6,7

Pass-through Enabled (read only)

Enables/disables Pass-through which allows you to transfer applications between a computer on the Allen-Bradley DH+ network and a terminal on the remote I/O link. A PLC-5 controller passes data between the two networks.

Last Chassis (ready only)

Indicates whether the terminal occupies the last module group in its assigned rack.

Baud

Steps through the communication rates with each key press: 57.6K (default), 115.2K, and 230.4K. The selected rate takes effect immediately. The maximum cable length is restricted at higher communication rates.

Exit

Returns to the Configuration Mode menu.

ControlNet Communication

The ControlNet screen lets you display communication settings for a ControlNet terminal. You are only allowed to change the Node Address and Underscan Delay settings.

IMPORTANT

Settings downloaded with a ControlNet application take priority over terminal settings and take effect immediately after the download.

ControlNet

New Node Address F2:	<input style="width: 100%;" type="text" value="##"/>	Restart Terminal F1
Active Node Address:	<input style="width: 100%;" type="text" value="03"/>	
Interscan Delay F3:	<input style="width: 100%;" type="text" value="100"/> ms	
FW Revision: #####	Serial #: #####	
Channel Status	Channel B	EXIT F16
Comms Status	Connected	

New Node Address

Opens the numeric entry scratchpad. Enter the node address (01...99 decimal) of the terminal and press the Enter ↵ key. On touch screen terminals, press the ↵ key on the scratchpad. The initial default is 3. The change takes effect after the terminal is reset. If you enter a value greater than the UMAX node address, the terminal will not go online with the network.

Active Node Address (read only)

Displays the current address of the PanelView terminal.

Underscan Delay

Opens the numeric entry scratchpad so you can change the Interscan Delay. Enter the delay (100...1000 milliseconds in multiples of 100) and press the Enter key. On touch screen terminals, press the ↵ key on the scratchpad. The initial default is 100. A change takes effect immediately.

FW Revision (read only)

Shows the revision # of the firmware in the ControlNet terminal.

Serial Number (read only)

Displays a unique, 32-bit serial number for the PanelView terminal.

Comms Status

Displays the current status of the communication card. **Connected** appears when the PanelView is connected to the network and operating properly.

Channel Status

Displays a value indicating the current status of channel A and B. The definition of each status condition follows the table. If multiple status conditions apply, the highest priority condition is displayed.

Displayed Value	Status AB	Displayed Value	Status AB	Displayed Value	Status AB	Displayed Value	Status AB
119	7 7	87	7 5	55	7 3	23	7 1
118	6 7	86	6 5	54	6 3	22	6 1
117	5 7	85	5 5	53	5 3	21	5 1
116	4 7	84	4 5	52	4 3	20	4 1

Displayed Value	Status AB	Displayed Value	Status AB	Displayed Value	Status AB	Displayed Value	Status AB
115	3 7	83	3 5	51	3 3	19	3 1
114	2 7	82	2 5	50	2 3	18	2 1
113	1 7	81	1 5	49	1 3	17	1 1
112	0 7	80	0 5	48	0 3	16	0 1
103	7 6	71	7 4	39	7 2	7	7 0
102	6 6	70	6 4	38	6 2	6	6 0
101	5 6	69	5 4	37	5 2	5	5 0
100	4 6	68	4 4	36	4 2	4	4 0
99	3 6	67	3 4	35	3 2	3	3 0
98	2 6	66	2 4	34	2 2	2	2 0
97	1 6	65	1 4	33	1 2	1	1 0
96	0 6	64	0 4	32	0 2	0	0 0

Status	Indicates	Priority
7	Terminal failure. Contact Allen-Bradley for technical support.	1 (Highest)
6	Self test being performed. Wait for end of test.	2
5	Incorrect node configuration. Check for duplicate nodes.	3
4	Incorrect network configuration (such as overflow/underflow if signaled by host, out-of-step). Check for a node greater than UMAX.	4
3	Cable fault or lonely connection (such as disconnected cable, redundancy warning).	5
2	Temporary network errors (such as bad MAC frame, screeners not programmed).	6
1	Channel ok.	7
0	Channel disabled.	8 (Lowest)

Restart Terminal

Resets the PanelView terminal. A new node address takes affect after a reset.

Exit

Returns to the Configuration Mode menu.

DeviceNet Communication

The DeviceNet screen lets you display or modify communication settings for a DeviceNet terminal.

IMPORTANT

Settings downloaded with a DeviceNet application take priority over terminal settings and take effect immediately after the download.

DeviceNet

New Node Address F2:	<input type="text"/>	Input Size:	0
Active Node Address:	2	Output Size:	0
New Baud F3:	<input type="text" value="125K"/>	Active Baud:	125K
Bus-off Interrupt F4:	<input type="text" value="Hold in Reset"/>		
Interscan Delay F5:	<input type="text" value="500"/> ms		
Comms Firmware Revision:	Serial Number:		

**Restart
Terminal
F1**

Mod/Net LED:
Not Connected

**EXIT
F16**

Restart Terminal

Resets the terminal.

New Node Address

Opens the numeric entry scratchpad. Type the node address (0...63) of the PanelView on the DeviceNet link or enter 64 to use the address stored on the communication card, Program Mode PGM displayed. Press the Enter ↵ key to store the address. On touch screen terminals, press the ↵ key on the scratchpad. A node change takes effect on reset. If 64 is entered, the node address can be set from the network using a DeviceNet network configuration tool.

Active Node Address (read only)

Displays the current network operating address of the PanelView terminal. The default is 63.

New Baud

Step through the communication rates with each key press: 125K (default), 250K, 500K, AutoBaud, PGM. If you select AutoBaud, the terminal determines the communication rate on startup (provided there is sufficient network traffic). If you select PGM, the terminal uses the most recent communication rate stored on the communication card. The selected communication rate takes effect on reset. The maximum cable length is restricted at higher communication rates.

Active Baud (read only)

Displays the current communication rate of the PanelView terminal. The new communication rate is displayed after a reset. If the communication rate was set to AutoBaud, active baud displays the rate set by the terminal. If the communication rate was set to PGM, the active baud displays the most recent communication rate stored on the communication card.

Bus-off Interrupt

Specifies what occurs when a CAN bus-off interrupt occurs on the DeviceNet network. The PanelView is not allowed network access when Hold on Reset is selected and a Bus-off Interrupt occurs.

- Hold in Reset: holds the PanelView and waits for a communication reset or a terminal reset.
- Reset and Continue Communication: resets DeviceNet communication and re-establishes the communication link.

Interscan Delay

Opens the numeric entry scratchpad so you can change the delay between scans of the Explicit-Client tags. Enter a value of 0...65535 milliseconds and press the Enter ↵ key. (On touch screen terminals, press the ↵ key on the scratchpad.) The default is 500 milliseconds.

This time delay is inserted between each full scan of the Explicit-Client tags in the current screen context. The value is initially set by the downloaded application but can be changed by an operator. The new value takes effect at the end of the current scan delay.

Explicit-client mode will generate low priority, network messaging at intervals less than 500 milliseconds.

Input Size

Displays the number of words (0...64) sent by the PanelView in an I/O message. The default value is 0, which indicates that no input data is exchanged with the scanner. This value is set by the downloaded application.

Output Size

Displays the number of words (0...64) received by the PanelView in an I/O message. The default value is 0, which indicates no output data is exchanged with the scanner. This value is set by the downloaded application.

Comm Status Indicator

- solid fill - normal operating state
- blinking - no communication established
- no fill - hardware failure

Exit

Returns to the Configuration Mode menu.

DF1 Communication

The DF1 screen lets you display or modify DF1/full duplex communication settings for a DF1 PanelView terminal.

IMPORTANT

Settings downloaded with a DF1 application have priority over terminal settings and take effect immediately after the download.

Typical DF1 Setup Screens

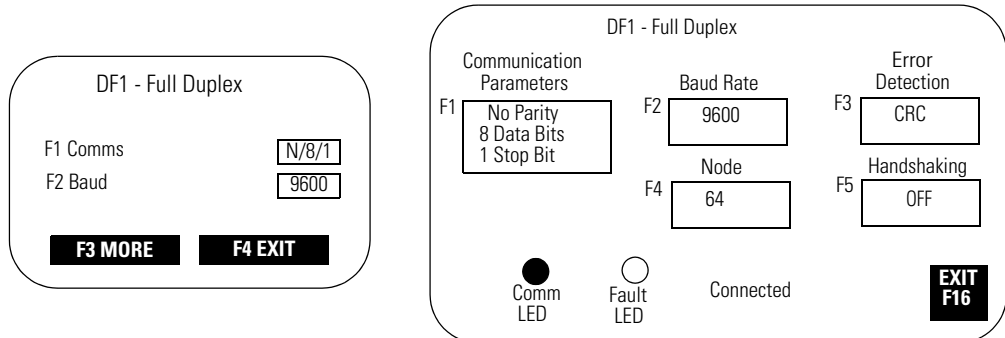

Communication Parameters

Sets the communication parameters for the DF1 port on the PanelView terminal. The settings must match the target device. Each key press toggles through the available combinations for:

- Parity = None (default), Even or Odd
- Data Bits = 8
- Stop Bits = 1 (default) or 2

The DF1 port on the PLC-5 controllers allows a parity of Even or None parity with 8 Data Bits. For the SLC controllers, the parity is fixed at None and uses CRC error detection.

Baud Rate

Steps through the communication rates for the DF1 communication port with each key press: 1200, 2400, 4800, 9600, and 19200. The initial default is 9600. The communication rate must match the communication rate of the target device.

Error Detection

Specifies the type of error checking performed on data. The default is Cyclic Redundancy Check (CRC).

- Block Check Character (BCC) - modulo-256 arithmetic sum of an array of data bytes used for medium-level data verification.
- Cyclic Redundancy Code (CRC) - calculated on an array of data bytes and used for high-level data verification.

Node

Specifies the node number (0...254 decimal) for DF1 network communication. For point-to-point communication with an SLC, PLC, MicroLogix controller or a 1761-NET DNI module, the default node number of 64 is used.

When you press F4, the numeric entry scratchpad opens. Enter a node number and press the Enter ↵ key. (On touch screen terminals, press the ↵ key on the scratchpad.)

Handshaking

Specifies the type of handshaking used by the RS-232 port.

- On (CTS/RTS enabled)
- OFF (CTS/RTS disabled)

Press F5 or touch the box to select an option. The default is Off.

Comm Status Indicator

- solid fill - normal operating state
- blinking - no communication established with logic controller
- no fill - hardware failure

Fault Status Indicator

- no fill - normal operating state
- blinking - hardware is functioning but an application is not loaded or the current application is corrupted.

Exit

Returns to the Configuration Mode menu.

EtherNet/IP Communication

The EtherNet/IP screen lets you display or modify some of the EtherNet/IP communication settings for an Ethernet PanelView terminal.

Additional parameters (Gateway Address, DNS Server and Domain Name, and Timeout values) are set in the Communication Setup dialog of the PanelBuilder32 software and downloaded with the application.

IMPORTANT

Settings downloaded with an EtherNet/IP application have priority over terminal settings and take effect immediately after the download.

The screenshot shows the EtherNet/IP configuration screen. At the top, it says "EtherNet/IP". Below this, there are several settings with input fields: "DHCP/BootP Enable" is set to "Enabled"; "IP Address" is "131.200.55.30"; "Subnet Mask" is "255.255.255.0"; "Interscan Delay F3" is "100 ms". Below these are "FW Revision: #####", "Serial #: #####", and "Ethernet Address: #####". At the bottom left, it says "Comms Status Attached". On the right side, there are two buttons: "Restart Terminal F1" and "EXIT F16".

DHCP/BootP Enable

DHCP/BootP Enable (Dynamic Host Configuration Protocol) automatically allocates network devices and configurations to newly attached devices on a TCP/IP network. When DHCP/BootP Enable is enabled, the PanelView terminal is automatically assigned an IP Address and Subnet Mask. These fields will be read only. Select disable to manually enter an IP Address or Subnet Mask for the PanelView terminal.

IMPORTANT

If DHCP/BootP is enabled in the downloaded application and then disabled on the terminal, the terminal will not have the necessary information (Gateway Address, IP address, Subnet Mask) to connect to the network on a restart. The Gateway Address cannot be entered at the terminal; you must configure this address in the Communication Setup dialog of PanelBuilder32.

IP Address

A unique address identifying the PanelView node on the EtherNet/IP network. The IP address is formatted as four sets of decimal numbers with periods between them (10.0.0.1). The range of values for the first set of decimal numbers is 1...255, unless all fields are set to 0.0.0.0. The range of values for the last three sets of decimal numbers is 0...255. The default value is 0.0.0.0. A change is not effective until you reset the terminal.

Subnet Mask

A 32-bit value forming the PanelView terminal's subnet mask. This parameter interprets IP addresses when the network is divided into multiple networks. The subnet mask is formatted as four sets of decimal numbers with periods between them (255.255.255.1). The range of values for the first set of decimal numbers is 1...255. The range of values for the last three sets of decimal numbers is 0...255. The value of 0.0.0.0 is not a valid subnet mask.

Interscan Delay

The length of time the PanelView terminal delays before re-reading data from the logic controller. Valid values range from 100...1,000 milliseconds. The default is 100. The terminal must be restarted for a new interscan delay value to be accepted.

Restart Terminal

Resets the terminal.

Exit

Returns to the Configuration Mode menu.

Configure Presets

Select Preset Operations from the Configuration Mode menu to set the values of control objects after a reset or power cycle. You can set presets to:

- values provided by the PanelView application.
- last values entered from terminal prior to a reset or power down.

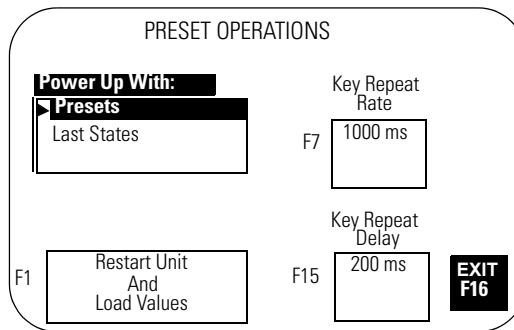

Power-up with Presets or Last States

Displays the current power-up selection. Use the up and down arrow keys on keypad terminals (or the up and down keys on touch screen terminals) to select an option. The selection takes effect the next time the terminal is powered on.

- Select **Presets** to load initial values of control objects (into controller data tables) with values supplied by the application.
- Select **Last States** to load initial values of control objects (into controller data tables) with values entered at the terminal prior to a terminal reset or power down.

Restart Unit and Load Values

Loads the values selected in the Power-up With list and resets the terminal.

Key Repeat Rate

Specifies the number of repeats that occur per second when a key is pressed and held. Steps through key repeat rates: 0 (disabled), 200 ms (5 times/s), 250 ms (4 times/s), 330 ms (3 times/sec), 500 ms (2 times/s), 1000 ms (1 time/s).

Key Repeat Delay

Specifies how long a key must be pressed before it is repeated. Steps through delay rates: 200 ms, 400 ms, 600 ms, 800 ms, 1000 ms, 1500 ms, 2000 ms, 2500 ms.

Exit

Returns to the Configuration Mode menu.

Viewing Terminal Information

Select Terminal Info from the Configuration Mode menu to display information about your terminal. This information may be needed when calling for technical support.

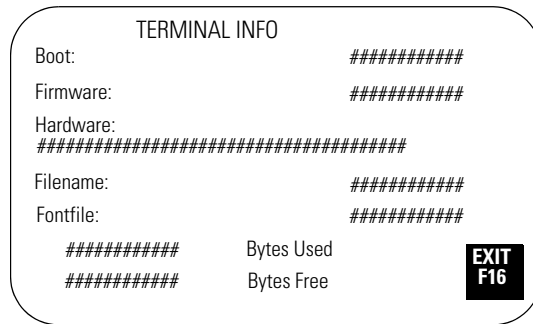

Boot

Displays the boot code revision.

Firmware

Displays the firmware revision.

Hardware

Displays the hardware configuration.

- Keypad (CPS)
- Touch Screen (TS)
- Keypad and Touch Screen (TS CPS)

Communication Port (P#.xxx, for example, P0.485 or P1.232)
Screen Size (SS5.5, SS6.0, SS9.0, SS10.0, SS14.0)

Filename

Displays the name of the active application file. If the application file exists but is invalid, the file name appears as *****.

- Bytes Used displays the number of bytes used by the loaded application.
- Bytes Free displays the number of bytes available.

Font File

Displays the name of the external font file used by the application.

Exit

Returns to the Configuration Mode menu.

Adjust Screen Parameters

Select Screen Setup from the Configuration Mode menu to adjust settings of the terminal display. Changes take effect immediately.

PanelView 300 Micro Terminal Screen Setup

The PanelView 300 Micro terminal backlight is always on and intensity is not adjustable.

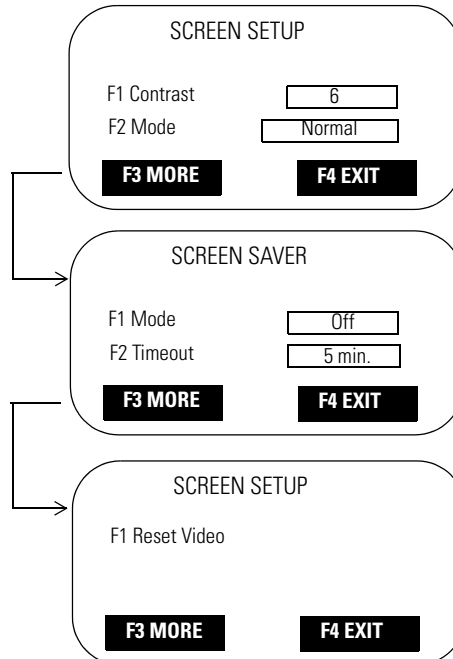

Contrast

Increases or decreases the display contrast. The contrast settings range from 0...10.

Video Mode

Toggles between normal video (dark text/graphics on a light background) and reverse video (light text/graphics on a dark background). Changes take effect immediately.

Screen Saver Mode

Mode - Select Timed or Off screen saver. When Timed, the screen intensity is reduced if user input or a controller screen change is not received within the time specified in the Screen Saver Timeout

Timeout

Specifies when an inactive screen enters screen saver mode. The timeout is adjusted in steps with each key press: 5, 10, 15, 20, 25, or 30 minutes.

Reset Video

Resets the display to normal (default settings). If the screen is set to a non-viewable setting, press the Left ◀ and Right ▶ arrow keys simultaneously to enter the configuration mode and enter screen setup to reset the screen settings.

PanelView 300 Terminal Screen Setup

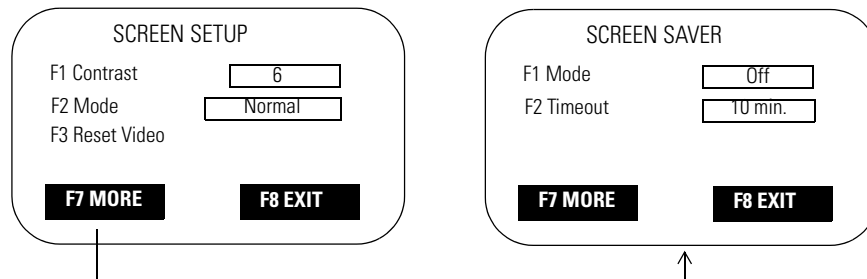

IMPORTANT

Certain settings may make viewing the screen difficult. Do not exit this screen until viewing adjustments are acceptable.

Contrast

Increases or decreases the display contrast. The contrast settings range from 0...10.

Video Mode

Toggles between normal video (dark text/graphics on a light background) and reverse video (light text/graphics on a dark background). Changes take effect immediately.

Reset Video

Resets the display to normal (default settings). The [F3] key is also active on the Configuration Mode menu. If the screen is set to a non-viewable setting, press the Left ◀ and Right ▶ arrow keys simultaneously. Then press [F3] to reset the screen.

Screen Saver Mode

Mode - Select Timed or Off screen saver. When Timed, the screen intensity is reduced if user input or a controller screen change is not received within the time specified in the Screen Saver Timeout

Timeout

Specifies when an inactive screen enters screen saver mode. The timeout is adjusted in steps with each key press: 5, 10, 15, 20, 25, or 30 minutes.

Exit

Returns to the Configuration Mode menu.

PanelView 550 Terminal Screen Setup

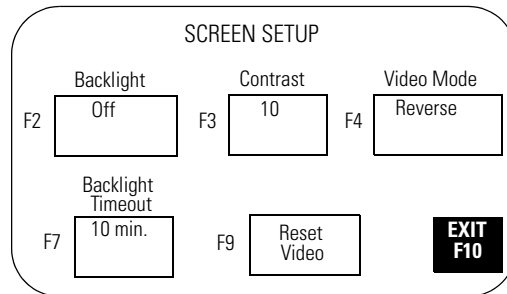

IMPORTANT

Certain settings may make viewing the screen difficult. Do not exit this screen until viewing adjustments are acceptable.

Backlight

Turns the backlight On, Off or to Timed mode. When set to Timed, the Backlight Timeout value determines when the backlight is turned off.

Contrast

Increases or decreases the display contrast. The contrast settings range from 0...10.

Video Mode

Toggles between normal video (dark text/graphics on a light background) and reverse video (light text/graphics on a dark background). Changes take effect immediately.

Backlight Timeout

Specifies when the backlight turns off if user input or a controller screen change is not received. The timeout settings are 5, 10, 20, 25, or 30 minutes. The Backlight Timeout value is used when the Backlight parameter is set to Timed.

Reset Video

Resets the display to normal (default settings). The reset video [F9] key is also active on the Configuration Mode menu. If the screen is set to a non-viewable setting, press the Left ◀ and Right ▶ arrow keys simultaneously. Then press [F9] to reset the screen.

Exit

Returns to the Configuration Mode menu.

PanelView 600/900/1000 Color Terminal Screen Setup

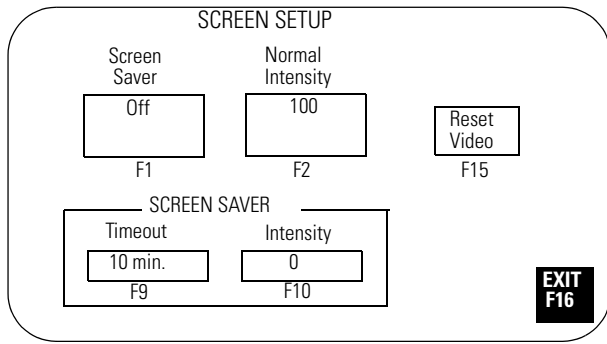

PV600/900/1000 color

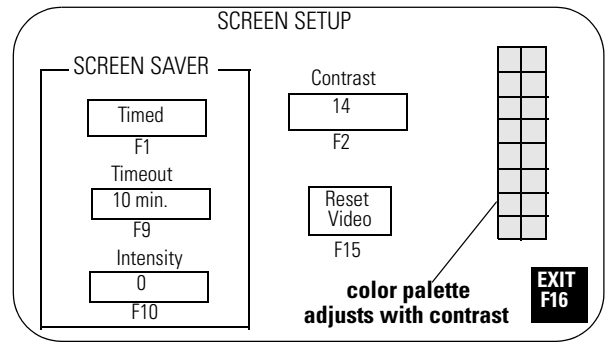

PV600 color touch-screen only

IMPORTANT Certain settings may make viewing the screen difficult. Do not exit this screen until viewing adjustments are acceptable.

Normal Intensity

Adjusts the intensity of the display with each key press. PV600/1000 terminal settings are 10...100, in 10 step increments. PV900 terminal settings are 50...100, in 10 step increments.

Contrast (PV600 touch-screen terminal only)

Adjusts the contrast of the display with each key press. Valid settings are 1...32. The initial default is 14.

Screen Saver Mode

Sets the screen saver to Timed or Off. When Timed, the screen intensity is reduced if user input or a controller screen change is not received within the time specified in the Screen Saver Timeout box.

Screen Saver Timeout

Specifies when an inactive screen enters screen saver mode. The timeout is adjusted in steps with each key press: 5, 10, 15, 20, 25, or 30 minutes.

Screen Saver Intensity

Adjusts the intensity of the display during screen saver mode. PV600/1000 settings are 0...100, in 10 step increments. PV600 touch-screen only settings are 0 or 100. PV900 settings are 0, and 50...100, in 10 step increments. It is recommended that you set the intensity to a value less than 100 to prolong the life of the backlight.

Reset Video

Resets the display to normal video (default settings). The reset video [F9] and [F15] keys are active on the Configuration Mode menu. If the screen is non-viewable, press the left ◀ and right ▶ arrow keys simultaneously. Then press [F9] or [F15] to reset the screen.

Exit

Returns to the Configuration Mode menu.

PanelView 900 Monochrome Terminal Screen Setup

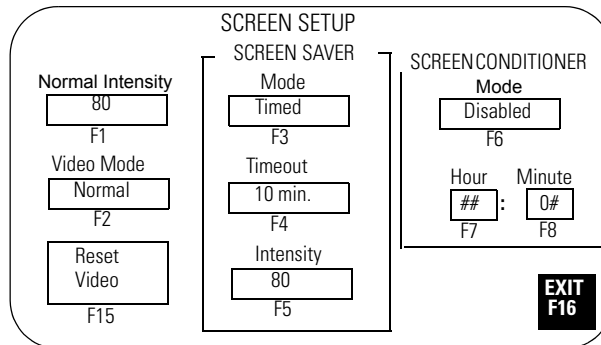

IMPORTANT

Certain settings may make viewing the screen difficult. Do not exit this screen until viewing adjustments are acceptable.

Normal Intensity

Adjusts the intensity of the display with each key press: 35, 40, 50, 60, 70, 80, 90, 100. A new setting takes effect immediately.

Video Mode

Toggles between normal video (light text/graphics on a dark background) and reverse video (dark text/graphics on a light background). The change takes effect immediately. Normal video is recommended.

Screen Saver Mode

Sets the screen saver to Timed or Off. When Timed, the screen intensity is reduced if user input or a controller screen change is not received within the time specified in the Screen Saver Timeout box.

Screen Saver Timeout

Specifies when an inactive screen enters screen saver mode. The timeout is adjusted in steps with each key press: 5, 10, 15, 20, 25, or 30 minutes.

Screen Saver Intensity

Adjusts the intensity of the display during screen saver mode. The intensity is adjusted with each key press: 0, 35, 40, 50, 60, 70, 80, 90, 100.

Screen Conditioner Mode

Enables or disables the screen conditioner. This parameter sets a daily schedule for conditioning the display of a PV900 monochrome terminal to prevent image burn-in.

The conditioning process takes approximately 30 minutes and will not start until the terminal is inactive and in screen saver mode. You can interrupt the screen saver or conditioner at any time by pressing a key or the touch screen. If the screen conditioner is interrupted, it will resume when the screen saver is reactivated.

If you do not use the conditioner, random pixels will illuminate around objects after a period of time (approximately one year).

Screen Conditioner Hour

Specifies the hour at which to start the screen conditioner. The numeric entry scratchpad opens. Enter a value between 0...23, then press the Enter ↵ key (on touch screen terminals, press the Enter key on the scratchpad).

Screen Conditioner Minute

Specifies the minute at which to start the screen conditioner. The numeric entry scratchpad opens. Enter a value between 0...59, then press the Enter ↵ key (on touch screen terminals, press the Enter key on the scratchpad).

Reset Video

Resets the display to normal video (default settings).

On keypad terminals, the reset video [F15] key is also active on the Configuration Mode menu. If the screen is non-viewable, press the Left ◀ and Right ▶ arrow keys simultaneously. Then press [F15] to reset the screen.

Exit

Returns to the Configuration Mode menu.

PanelView 1000 Grayscale Terminal Screen Setup

SCREEN SETUP

Screen Saver <div style="border: 1px solid black; padding: 2px; width: 60px; margin: 0 auto;">Off</div> F1	Video Mode <div style="border: 1px solid black; padding: 2px; width: 60px; margin: 0 auto;">Normal</div> F2	<div style="border: 1px solid black; padding: 2px; width: 60px; margin: 0 auto;">Reset Video</div> F15
SCREEN SAVER		
Timeout <div style="border: 1px solid black; padding: 2px; width: 60px; margin: 0 auto;">10 min.</div> F9	Intensity <div style="border: 1px solid black; padding: 2px; width: 60px; margin: 0 auto;">0</div> F10	<div style="background-color: black; color: white; padding: 5px; width: 40px; margin: 0 auto; font-weight: bold;">EXIT F16</div>

IMPORTANT

Certain settings may make viewing the screen difficult. Do not exit this screen until viewing adjustments are acceptable.

Video Mode

Toggles between normal video (darker text/graphics on a light background) and reverse video (lighter text/graphics on a dark background). The change takes effect immediately. Normal video is recommended.

Screen Saver Mode

Sets the screen saver to Timed or Off. When Timed, the screen intensity is reduced if user input or a controller screen change is not received within the time specified in the Screen Saver Timeout box.

Screen Saver Timeout

Specifies when an inactive screen enters screen saver mode. The timeout is adjusted in 5 minute increments with each key press, from 5...30 minutes.

Screen Saver Intensity

Adjusts the intensity of the display during screen saver mode. Settings are 0 (lowest intensity) or 100 (highest intensity). 0 is recommended to prolong the display life.

Reset Video

Resets the display to normal video (default settings).

On keypad terminals, the reset video [F15] key is also active on the Configuration Mode menu. If the screen is non-viewable, press the Left ◀ and Right ▶ arrow keys simultaneously. Then press reset video [F15] to reset the screen.

Exit

Returns to the Configuration Mode menu.

PanelView 1400 Color Terminal Screen Setup

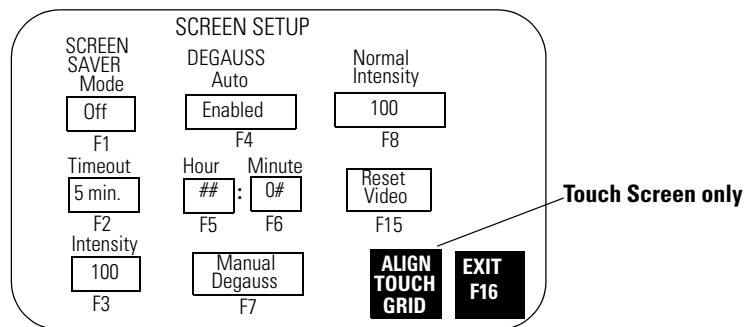

IMPORTANT

Certain settings may make viewing the screen difficult. Do not exit this screen until viewing adjustments are acceptable.

Screen Saver Mode

Sets the screen saver to Timed or Off. When Timed, the screen intensity is reduced if user input or a controller screen change is not received within the time specified in the Screen Saver Timeout box.

Screen Saver Timeout

Specifies when an inactive screen enters screen saver mode. The timeout is adjusted in 5 minute increments with each key press, from 5...30 minutes.

Screen Saver Intensity

Adjusts the intensity of the display during screen saver mode. The intensity is adjusted with each key press: 0, 25, 50, 75, or 100.

Degauss Auto

Enables or disables automatic degaussing. The degauss process takes a few seconds and will not start until the terminal is inactive. Automatic degaussing occurs at midnight unless you adjust the hour and time parameters.

Degauss Hour

Specifies the hour to start automatic degaussing. The numeric entry scratchpad opens. Enter a value between 0...23, then press the Enter ↵ key (on touch screen terminals, press the Enter key on the scratchpad).

Degauss Minute

Specifies the minute to start automatic degaussing. The numeric entry scratchpad opens. Enter a value between 0...59, then press the Enter ↵ key (on touch screen terminals, press the Enter key on the scratchpad).

Manual Degauss

Allows you to manually degauss the display. When you press [F7], the display is degaussed immediately.

Normal Intensity

Adjusts the intensity of the display with each key press: 25, 50, 75, or 100. The new setting takes effect immediately.

Reset Video

Resets the display to normal video (default settings).

On keypad terminals, the reset video [F15] key is also active on the Configuration Mode menu. If the screen is non-viewable, press the Left ◀ and Right ▶ arrow keys simultaneously. Then press [F15] to reset the screen.

Align Touch Grid - PV1400 Touch Screen Terminal only

Opens the touch alignment screen, which lets you realign the screen with the touch grid. This function is useful when the terminal is positioned at an angle and viewing the screen is difficult unless you realign the screen.

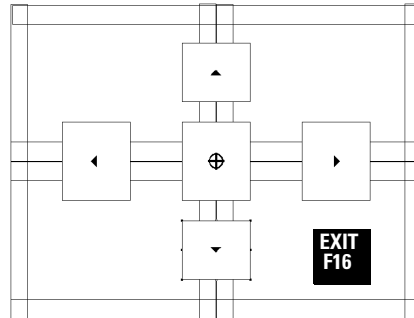

Move the screen until it aligns with the touch cells. Alignment changes are permanent.

Press	To
▲	Move the screen up one pixel.
▼	Move the screen down one pixel.
▶	Move the screen to the right two pixels.
◀	Move the screen to the left two pixels.
⊕	Move the screen to its factory default position.
Exit	Exit the touch alignment screen and return to Screen Setup.

Exit

Returns to the Configuration Mode menu.

Set the Time and Date

Select Date/Time from the Configuration Mode menu to reset the date and/or time.

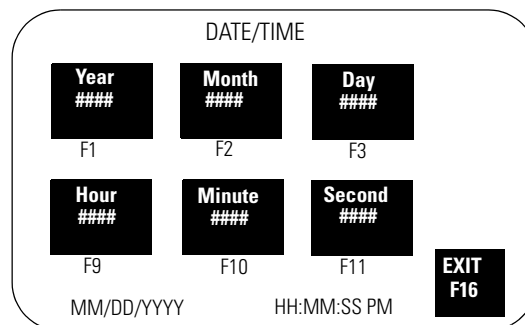

Set the Time

Use screen buttons (touch screens) or function keys to set the time.

On PV300, PV300 Micro Terminals	On PV550/PV600 Terminals Press	On PV900/1000/1400 Terminals Press	To Set
Use the left and right cursor keys to select the time or date item you want to change. Use the up and down cursor keys to adjust the selected date or time variable.	Hours button [F6]	Hour button [F9] key	Current hour
	Minute button [F7]	Minute button [F10]	Minutes
	Second button [F8]	Second button [F11]	Seconds

The scratchpad opens to enter each setting. Use the terminal keypad to enter the values. Press ↵ after each entry. Changes take effect immediately.

Set the Date

Use screen buttons (touch screens) or function keys to set the date.

Press	To
Year button [F1] key	Set current year
Month button [F2]	Set month (1...12)
Day button [F3]	Set day (1...31)

The scratchpad opens to enter each setting. Use the terminal keypad to enter the values. Press ↵ after each entry. Changes take effect immediately.

Exit

Returns to the Configuration Mode menu.

Set Up the Printer

Select Printer Setup from the Configuration Mode menu to set parameters for those terminals equipped with an RS-232 printer port. Any printer that supports the IBM enhanced character set can be connected to the RS-232 printer port.

The screenshot shows a terminal window titled "PRINTER SETUP". The menu is organized into three columns: Handshaking, Communication Parameters, and Baud Rate. Below these are options for Top Of Form, Port Mode, and an EXIT key.

Handshaking	Communication Parameters	Baud Rate
XON/XOFF F1	No Parity 8 Data Bits 1 Stop Bit F2	19200 F3
Top Of Form F9	Port Mode Printing Enabled F10	EXIT F16

IMPORTANT

The PanelView 300 Micro terminal does not support printer functions.

Printer settings are maintained between power cycles.

Page format parameters for printing are defined in the Terminal Setup dialog of PanelBuilder32 software and downloaded with the application.

Handshaking

Specifies the type of handshaking used by the RS-232 port.

- None (initial default)
- Hardware
- XON/XOFF

If you change the type of handshaking used, you must reset your PanelView before the change takes effect.

Communication Parameters

Sets the communication parameters for the printer port. Each key press toggles through the available combinations for:

- Parity (None, Even or Odd)
- Data Bits (7 or 8)
- Stop Bits (1 or 2)

Baud Rate

Sets the communication rate of the printer port. The communication rate must match the communication rate of the printer. The communication rate is adjusted with each key press: 1200, 2400, 4800, 9600, and 19200. The initial default is 9600.

Top of Form

Notifies the PanelView terminal the printer is at the top of a page.

Manually adjust the printer to the top of the page before pressing the Top of Form button. The printer also uses the Perforation Skip Value (if defined in the Printer Setup of the PanelBuilder32 software) when the Top of Form button is pressed.

On powerup, the terminal assumes the printer is at the top of a page. We recommend that you also set the PanelView terminal to the top of the page so that the printer and PanelView are at the same starting point. Otherwise your printout may not start at the top of the page.

Port Mode

Enables or disables printing for the RS-232 port.

The RS-232 port on some terminals supports both printing and application transfers. If you disable printing, the port is used for application transfers.

Exit

Returns to the Configuration Mode menu.

Using a Memory Card

Chapter Objectives

This chapter describes:

- supported memory cards.
- using the memory card retainer.
- loading application from a memory card.
- loading application on a memory card.
- storing font files on a memory card.
- removing a memory card.

Supported Memory Cards

Memory cards are available to transfer application files to/from a PanelView terminal with a memory card slot. The PanelView 300 Micro terminal does not support a memory card.

PanelView terminals running firmware 3.0 (or later) and computers with an ATA card drive support the following cards.

- 4M flash ATA card (Cat. No. 2711-NM24)⁽¹⁾
- 8M flash ATA card (Cat. No. 2711-NM28)⁽¹⁾
- 16M flash ATA card (Cat. No. 2711-NM216)⁽¹⁾
- 64M flash ATA card (Cat. No. 2711-NM232)

All PanelView terminals and computers with a DataBook TMB240 or TMB250 card drive support these cards:

- 256K flash memory card (Cat. No. 2711-NM11)⁽¹⁾
- 1M flash memory card (Cat. No. 2711-NM12)⁽¹⁾
- 2M flash memory card (Cat. No. 2711-NM13)⁽²⁾
- 4M flash memory card (Cat. No. 2711-NM14)⁽²⁾
- 10M flash memory card (Cat. No. 2711-NM15)⁽²⁾

⁽¹⁾ No longer available.

⁽²⁾ Limited availability.

Use the Memory Card Retainer

A memory card retainer (catalog no. 2711-NMCC, -NMCD, -NMCE) is shipped with all PanelView terminals, except the PV300 Micro terminal and the PV1400 terminal. It is required for:

- UL508 installations.
- vibration/mechanical shock environments.
- CE certified installations.
- installations where the application uses a font file on a memory card, and the card must remain in the terminal during operation.

The following illustration shows the memory card and the memory card retainer. The card loads in the back of the terminal with the key slot on top.

Memory Card and Memory Card Retainer

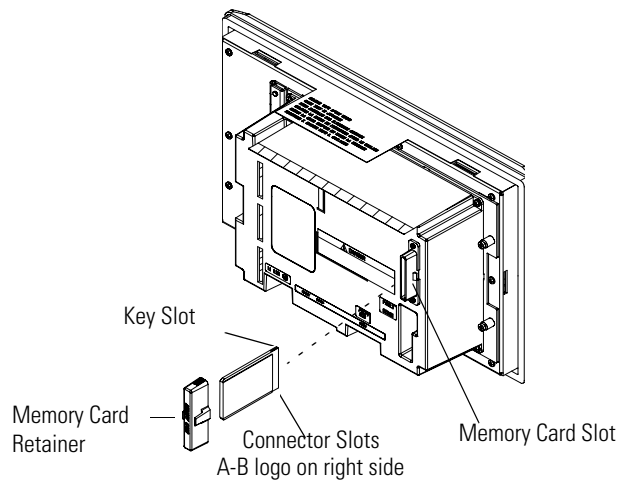

TIP

The back of the PanelView 900 terminal is shown above. The location of the card slot will vary between the different terminals.

The memory card retainer protects against:

- electrical shock from loose high voltage wires in an electrical enclosure per UL508.

ATTENTION

When permanently installing a memory card in an electrical enclosure, the memory card retainer must be used to avoid accidental contact of high voltage leads to metal surfaces on the card. Failure to use the retainer could result in physical injury or damage to the terminal.

- electrostatic discharge (ESD) up to 15KV.

ATTENTION

Without the memory card retainer installed, electrostatic discharge could reset or damage the PanelView terminal.

- accidental removal or ejection of the memory card from the card slot.

ATTENTION

Accidental removal of an ATA flash card from the card slot could result in damage to the card.

Load Application from a Memory Card

The procedure below shows how to load an application on a memory card into the PanelView terminal.

WARNING



Explosion Hazard - Do not install or remove memory card unless power has been switched off or the area is known to be non-hazardous.

Follow these steps to load an application from a memory card.

1. Insert the memory card in the card slot of the terminal.
If the terminal does not have an application loaded, the Configuration Mode menu appears. Skip step 2.
2. Open the Configuration Mode menu by simultaneously pressing the Left ◀ and Right ▶ arrows (on keypad terminals), or the Goto Config. Screen button (on touch screen terminals).

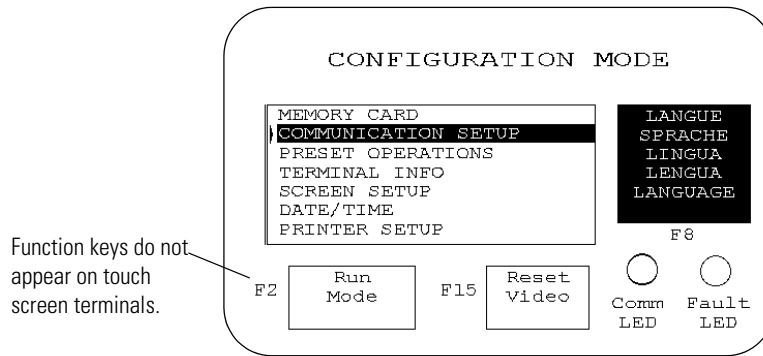

3. Select Memory Card and press the Enter ↵ key.

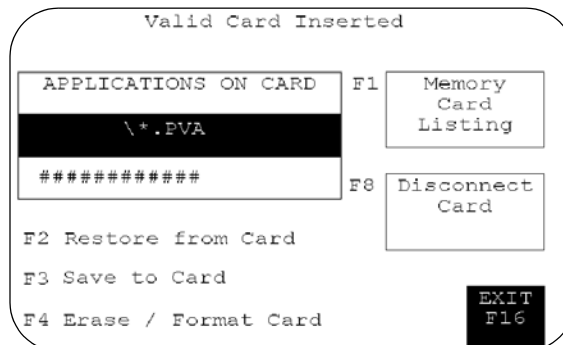

4. Press Memory Card Listing, [F1] on keypad terminals, until the application file you want to load is displayed.
5. Press Restore From Card, [F2] on keypad terminals, to begin the transfer.

Because this operation overwrites the current application in the terminal, you are prompted to abort or continue.

Proceed with download?

F1 - Abort |

F2 - Continue

The terminal displays the status of the transfer.

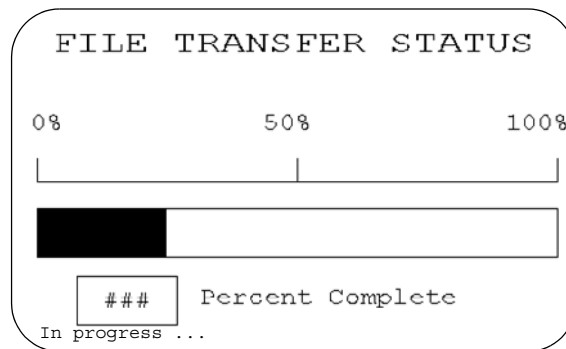

6. When the transfer is complete, the PanelView terminal checks the validity of the application, resets and runs the application.

Load Application on a Memory Card

The steps below show how to load an application in the terminal onto a memory card.

WARNING



Explosion Hazard - Do not install or remove memory card unless power has been switched off or the area is known to be non-hazardous.

Follow these steps to transfer an application to a memory card.

1. Insert the memory card into the card slot of the terminal.
2. Open the Configuration Mode menu by simultaneously pressing the Left ◀ and Right ▶ arrows (on keypad terminals), or the Goto Config. Screen button (on touch screen terminals).

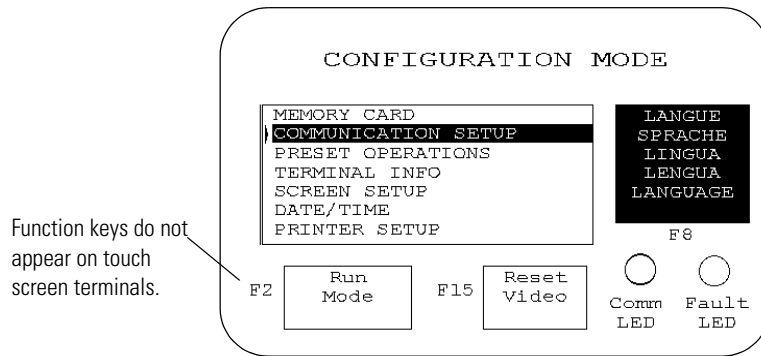

3. Select Memory Card and press the Enter ↵ key.

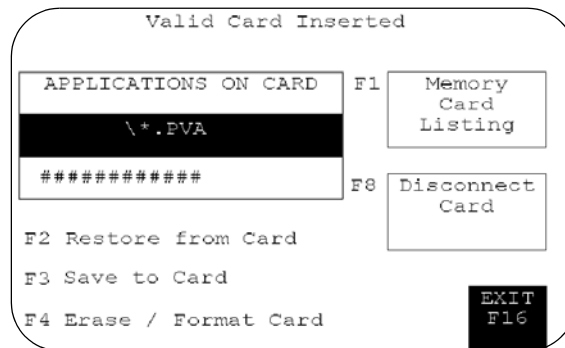

4. If necessary, press Erase/Format Card, [F4] key on keypad terminals, to format or erase a 2711-NM11, 2711-NM12, 2711-NM13, 2711-NM14, or 2711-NM15 memory card.

IMPORTANT

Do not perform this operation on a 2711-NM2xx ATA card (where xx is size in megabytes). The card becomes inoperable.

Because this operation erases all data on the memory card, you are prompted to abort or continue.

Format erases entire card?

F1 - Abort

F2 - Continue

5. Press Save to Card, [F3] on keypad terminals, to transfer the application in the terminal to the card.

If the application already exists on the memory card, you are prompted to abort or continue.

The .PVA file exists:

F1 - Abort

F2 - Upload with new PVA file

The terminal displays the status of the transfer.

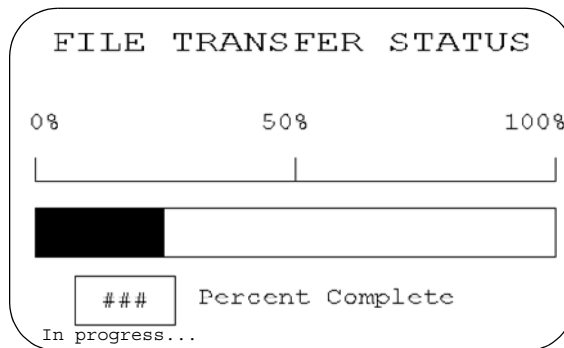

When the transfer is complete, the application file name appears in the Applications on Card list.

6. Press Memory Card Listing, [F1] key on keypad terminals, to scroll through the list.

TIP

If you upload a file that exists on the memory card, the uploaded file name is altered with a sequential digit as a suffix. For example, Control.pva becomes Control0.pva.

For files with eight character names, a digit overwrites the last character. For example, Motorcon.pva becomes Motorco0.pva.

Store Font Files on a Memory Card

Memory cards also store font files for languages used by PanelView terminal applications. The font file contains the character set for the language.

The memory card containing the font file must be inserted in the PanelView terminal while the application is running. The terminal uses the font file to display characters on the application screen.

To view the name of the font file used by an application, select Terminal Info from the Configuration Mode menu.

Because the memory card must remain in the terminal while the application is running, we recommend that you use the memory card retainer (Cat. No. 2711-NMCC, 2711-NMCD, 2711-NMCE) to secure the card in the card slot. The retainer ensures the card is not accidentally removed or dislodged during terminal operation.

Remove a Memory Card

Follow the procedure below to remove a memory card from the PanelView terminal. Failure to follow this procedure may result in damage to the card.

1. Select Memory Card from the Configuration Mode menu.
2. Press the Disconnect Card button.

This ensures that all files are closed on the card. A message prompts you to remove the card from the slot. You can continue or abort the operation.

3. Press the Continue button.
4. Remove the memory card from the card slot.

On PV1400 terminals, press the Memory Card Eject button.

Running Applications

Chapter Objectives

This chapter describes operating procedures common to most applications.

- Screen security
- Push button operation
- Control lists
- Numeric entry controls
- ASCII entry controls
- Screen selectors
- List indicators
- Multistate indicators
- Alarms
- Printing
- Time or date
- Message displays
- Numeric data displays
- Bar graphs
- Analog gauges

Application Information

The application designer is responsible for documenting the operation of an application. Before running the application, you should understand what processes are being controlled and monitored.

ATTENTION

Do not press multiple touch screen objects at the same time. Pressing multiple objects simultaneously may result in unintended operation.

Important Information for PanelView 300 Micro Terminal Operations

The Up/Down and Left/Right cursor keys on the PanelView 300 Micro terminal may be assigned as additional function keys. It is the responsibility of the application designer to inform the operator of the assigned functions.

If cursor keys are assigned as function keys, the following (applies to the currently active screen):

- List Selectors and Increment / Decrement objects are disabled if the Up or Down cursor keys are used as function keys.

- Simultaneous pressing of Left and Right cursor keys does not cause the terminal to enter Configuration Mode if the Left and Right cursor keys are assigned as function keys anywhere in the application.
- If both the Left/Right cursor keys are used on a screen and more than one cursor operated object is present on the screen, all of the cursor operated objects must be assigned to a function key.

Screen Security

Access to some application screens (including the terminal configuration screens) may be restricted. Secured screens require you to enter a password before the screen is displayed. It is the responsibility of the application designer to provide operators with required passwords.

Other screens may allow an authorized operator to select and change the passwords of operators at the terminal.

Push Button Operation

Screen push buttons function like mechanical push buttons.

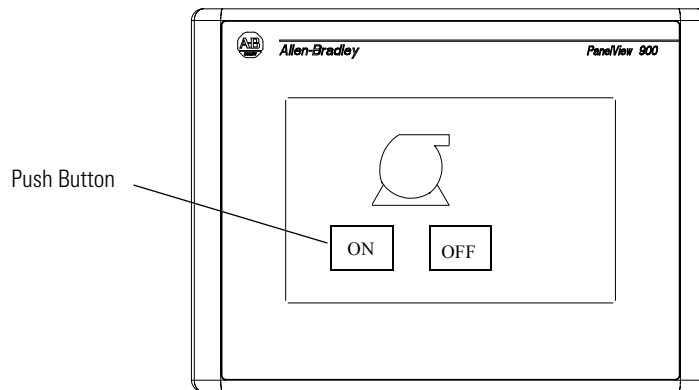

Push buttons have a variety of appearances. Push buttons may change their inner text, fill pattern, border, or shape when pressed (each state assigned different attributes).



The following are common to most push buttons:

- All push buttons are momentarily disabled (0.5 second) after a screen change. This prevents multiple buttons, in the same location on different screens, from being pressed inadvertently.
- All push buttons must be released on the previous screen before buttons can be pressed on the new screen.
- Momentary push buttons are assigned a hold time. The hold time maintains the pressed state so that each change of state can be read by the controller at least once. The hold time varies between 0 and 1 second depending on the configured setting.

Control Lists

Control lists perform functions similar to push buttons. They can modify either individual bits or values at a controller address.

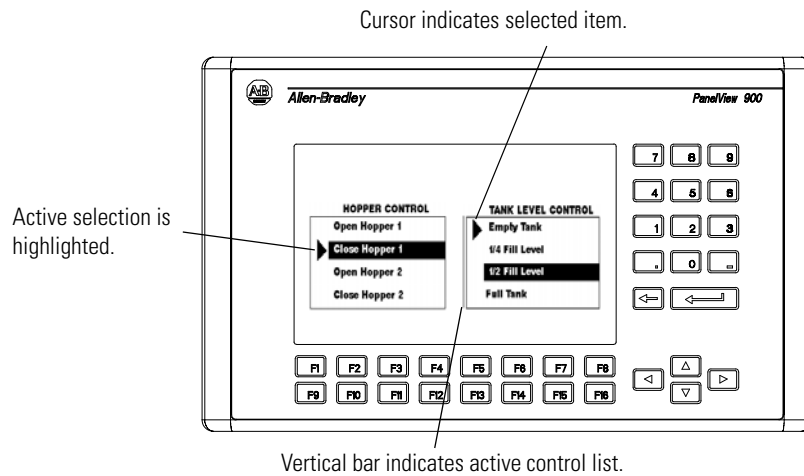

Active List Item

Active item is highlighted.

Active Control List

Has a vertical indicator bar on the left side of the list. Only one control list or numeric entry cursor point can be active on a screen.

To activate a control list:

- touch the object (touch screen terminals only)
- or press the assigned function key
- or on a screen with multiple control lists or numeric entry cursor points, press the Left ◀ or Right ▶ arrows to move the indicator bar between the objects.

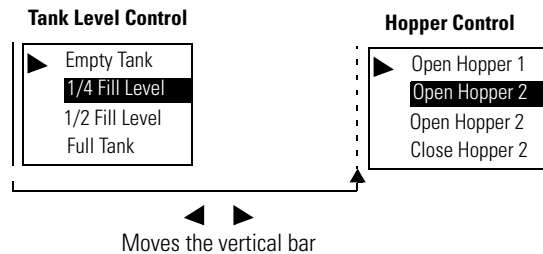

Cursor

Indicates the selected item. Move the cursor up or down the control list using the Up ▼ and Down ▲ arrow keys. Cursor operation is configured by the application designer. If the cursor is at the first or last item in a control list, pressing the Up arrow (when at the top) or the Down arrow (when at the bottom) will either:



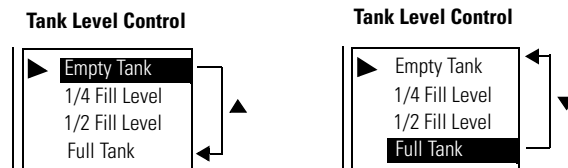





- cause no movement of the cursor.
- move the cursor to the top or bottom of the list.



If the list contains more items than can appear at one time, the list scrolls. If the cursor is at the top or bottom of a scrolling list, the list scrolls one row at a time as the arrow keys are pressed.

List Keys

Touch screen terminals require list keys on the screen to move the cursor in a control list and select entries. The following table shows the list keys.

List Key	Type	Description
	Move Up	Moves the cursor to the previous item in the list.
	Move Down	Moves the cursor to the next item in the list.
	Home	Moves the cursor to the first item in the list.
	End	Moves the cursor to the last item in the list.
	Page Up	Moves the cursor up one page in a scrolling list.
	Page Down	Moves the cursor down one page in a scrolling list.
	Backspace	Returns the cursor to the currently highlighted selection.
	Enter	Confirms a selection and sends the value to the controller if Write on Enter was configured for the control list.

Cursor-piloted Control Lists

On a piloted control list, some items are under controller operation only. In addition, some items may be designated as inactive. You cannot select controller items or inactive items. In both cases, the cursor is hollow when you select the item.

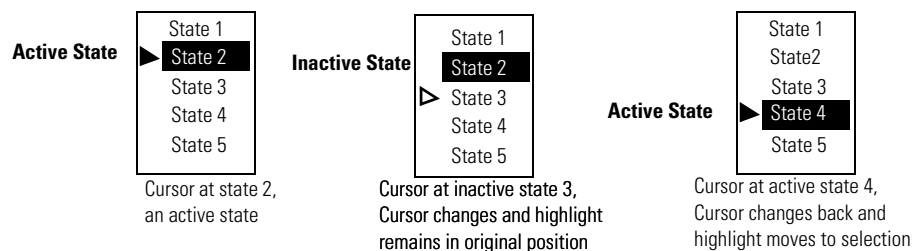

Follow these steps to select an item on a control list.

1. Select the control list by:
 - touching the screen object (touch screen terminals only).
 - pressing its function key.
 - pressing the Left ◀ or Right ▶ arrow keys until the control list has a vertical bar indicating it is active.
2. Move the cursor up or down the list using the Up ▲ or Down ▼ arrows. If the cursor is hollow, the item cannot be selected.
3. Depending on the application design, you may or may not have to press ↵ to enter the selection indicated by the cursor.

Two types of controls allow a numeric value at a controller address: Cursor Point and Keypad Enable button.

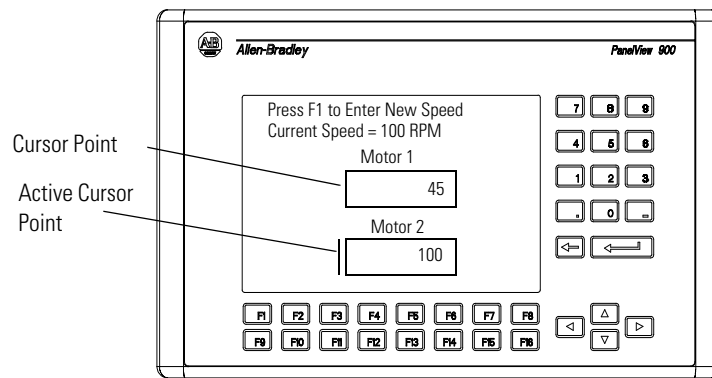

Numeric Entry Cursor Point

34962

Cursor points appear as a box. A vertical line on the left side of the box appears when the cursor point is selected. Data is entered in a numeric entry scratchpad.

Keypad Enable Button

Enter Value
367

A keypad enable button appears like a standard push button. The data displayed in the button is the last value sent to the button's tag address. When selected, a numeric entry scratchpad opens.

Scratchpad

Both controls display a numeric entry scratchpad in the center of the screen. The scratchpad shows the current value entered and the range of possible values you can enter.

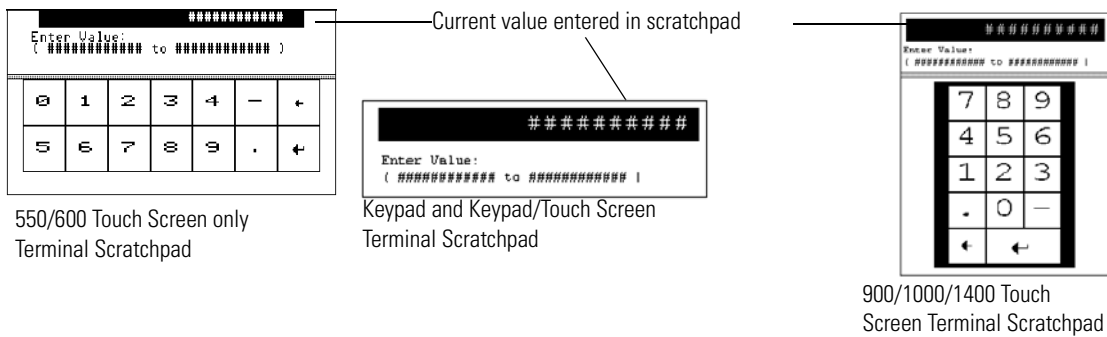

During data entry, wait until the number you enter appears in the scratchpad before entering the next number.

Follow these steps to enter a cursor point.

1. Select the cursor point by:
 - touching the object (touch screen terminal only).
 - pressing the associated function key.
 - pressing the Left ◀ or Right ▶ arrows until the cursor point shows a vertical bar.
2. Press Enter ↵ or type the first digit of the number you want to enter.
The scratchpad opens.
3. Enter the value using the terminal keypad and press Enter ↵.

Follow these steps to enter a value by using the keypad enable button.

1. Press the keypad enable button.
The scratchpad opens.
2. Enter the value by using the terminal keypad and press Enter ↵.

Follow these steps to change an entry on a scratchpad.

1. Press the backspace ←key to delete one character at a time.
2. Enter a new value and press Enter ↵.

Follow these steps to cancel a scratchpad.

1. Press the Backspace ←key to delete one character at a time.
When pressing the Backspace ←key in an empty scratchpad

PanelView 300, 300 Micro Terminal Thumbwheel Scratchpad

The thumbwheel scratch pad lets you enter values on terminals without a numeric keypad or touch screen by cycling through the available characters one position at a time. Use the Up ▲ and Down ▼ cursors to cycle through the available characters. The thumbwheel scratchpad shows:

- display area where the value is entered or modified
- ESC - F1 key to exit the scratchpad without saving any changes or sending a value

Scroll through and select digits 0...9. You can select the sign (+, -) from the leftmost column. If the decimal point is keypad controlled, you can also select a decimal point (if one has not been previously selected).

Keys	Function
Left / Right Cursor ◀ ▶	Moves the cursor one position to the left or right in the display area. The cursor wraps around to the opposite side when reaching the leftmost or rightmost character,
Up /Down Cursor ▲ ▼	Cycles through the available characters at the cursor position.
Enter Key	Send the numeric value to the logic controller. Leading and trailing spaces are removed.

TIP The Up/Down/Left/Right cursor keys can have an autorepeat configured. If you hold down the key, the key is repeated at the set key repeat rate.

ASCII Entry Controls

ASCII entry controls let you send an alphanumeric string (up to 128 characters) to a controller. Like numeric entry controls, the ASCII entry control can appear on a screen as a keypad enable button or a cursor point. When either object is activated, the ASCII scratchpad opens. The look of the scratchpad depends on the terminal.

ASCII Scratchpad - Keypad or Keypad/Touch Screen Terminals

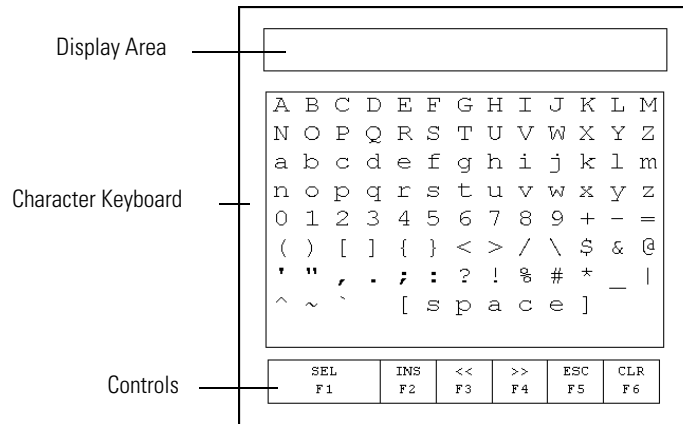

Select characters from the Character Keyboard by moving the cursor (with the keypad arrows) over a character and pressing the Sel-F1 function key. The character appears in the Display Area. This area scrolls so you can enter a string that is longer than the Display Area. All characters are sent to the controller even if not visible.

After entering characters, press ↵ to send the string to the controller. The leftmost character is placed in the high byte of the first word (of the write tag), the next character in the low byte, and so on.

TIP

DeviceNet ASCII entry allows for byte swapping.

Controls	Location	Function
◀▶▲▼	Terminal Keypad	Moves the cursor up, down, left, or right in the Character Keyboard.
"	Terminal Keypad	Deletes the character to the left of the cursor in the Display Area. If the cursor is at the leftmost position when you press ←, the scratchpad closes.
∅	Terminal Keypad	Sends the character string to the assigned write tag address in the controller. When opening the ASCII scratchpad, the string is highlighted. If you select a character immediately, the terminal clears the Display Area and displays the selected character. If you press a control key, the terminal continues to display the existing string, allowing you to edit it.
SEL F1	Function Keys	Selects the highlighted character and places it at the cursor position in the Display Area.
INS F2	Function Keys	Toggles between Insert and Overstrike mode. Overstrike mode appears in reverse video. In Insert mode, the selected character is inserted before the cursor in the Display Area. If the maximum number of characters is entered in the Display Area, new characters are ignored. In Overstrike mode, the selected character replaces the character at the cursor in the Display Area.
<< F3	Function Keys	Moves the cursor one character to the left in the Display Area.

ASCII Scratchpad - PV550/600 Touch Screen Terminals

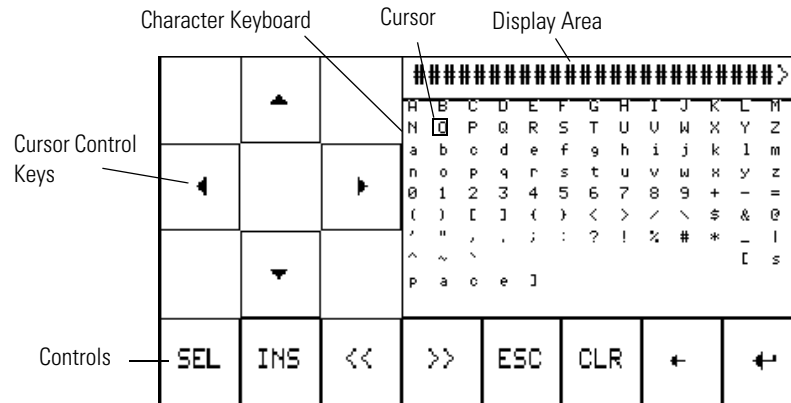

To select characters from the Character Keyboard, press the cursor control keys to move the cursor over a character and then press the SEL key. The character is entered in the Display Area. This area scrolls so you can enter a string that is longer than the Display Area. All characters are sent to the controller even if not visible.

After entering the characters, press ↵ to send the string to the controller. The leftmost character is placed in the high byte of the first word (of the write tag), the next character in the low byte, and so on.

TIP

DeviceNet ASCII entry allows for byte swapping.

Controls	Function
⬅➡⬆⬇	Moves the cursor up, down, left, or right in the Character Keyboard.
SEL	Selects the highlighted character and places it at the cursor position in the Display Area.
INS	Toggles between Insert and Overstrike mode. Overstrike mode appears in reverse video. In Insert mode, the selected character is inserted before the cursor in the Display Area. If the maximum number of characters is entered in the Display Area, new characters are ignored. In Overstrike mode, the selected character replaces the character at the cursor in the Display Area.
<<	Moves the cursor one character to the left in the Display Area.
>>	Moves the cursor one character to the right in the Display Area.
ESC	Closes the scratchpad without making any changes
CLR	Clears the string in the Display Area.
⌫	Deletes the character to the left of the cursor in the Display Area.
↵	Sends the character string to the assigned write tag address in the controller. When opening the ASCII scratchpad, the string is highlighted. If you select a character immediately, the terminal clears the Display Area and displays the selected character. If you press a control key, the terminal continues to display the existing string so you can edit it.

ASCII Scratchpad - PV900/1000/1400 Touch Screen Terminals

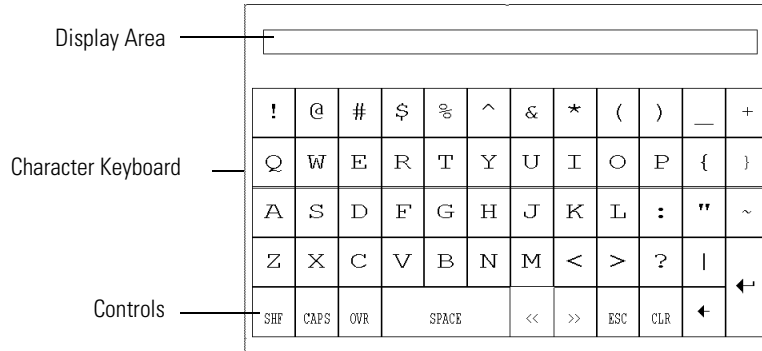

Select characters by touching the Character Keyboard on the screen. The character is entered in the Display Area. This area scrolls so you can enter a string that is longer than the Display Area. All characters are sent to the controller even if not visible.

After entering the characters, press ↵ on the scratchpad to send the characters to the controller. The leftmost character is placed in the high byte of the first word (of the write tag), the next character in the low byte, and so on.

TIP DeviceNet ASCII entry allows for byte swapping.

Controls	Function
SHF (Shift)	By default this function is off and keys are in unshifted state. When you press SHF, the button appears in reverse video. All character keys, including numbers and symbols, appear in the shifted state. For example, a becomes A; 2 becomes @.
CAPS	By default, keys appear in lowercase. When you press CAPS, the button appears in reverse video. Letters appear and are entered in uppercase but numbers and symbols are not shifted. This state is maintained between power cycles.
INS	Toggles between Insert and Overstrike mode. Overstrike mode appears in reverse video. In Insert mode, the selected character is inserted before the cursor in the Display Area. If the maximum number of characters is entered in the Display Area, new characters are ignored. In Overstrike mode, the selected character is replaced at the cursor in the Display Area.
<<	Moves the cursor one character to the left in the Display Area.
>>	Moves the cursor one character to the right in the Display Area.
ESC	Closes the scratchpad without making any changes.

Controls	Function
CLR	Clears the string in the Display Area.
..	Deletes the character to the left of the cursor in the Display Area.
↵	Sends the character string to the assigned write tag address in the controller. After pressing ↵ to open the ASCII scratchpad, the string is highlighted. If you select a character immediately, the terminal clears the Display Area and displays the selected character. If you press a control key, the terminal continues to display the existing string so you can edit it.

ASCII Scratchpads in Other Languages

The ASCII Scratchpad is available with character keyboards in:

- French.
- German.
- Italian.
- Spanish.

If the PanelView terminal is configured for operation in one these languages, the ASCII scratchpad will display the appropriate Character Keyboard.

The SHF control toggles between SHF/SHF2. In SHF mode, the Character Keyboard displays the shifted state characters (for example, a to A, and 3 to #). In SHF2 mode, the Character Keyboard displays additional characters available for the language.

Screen Selectors

The 2 types of screen selector controls are Screen List Selectors and Screen buttons.

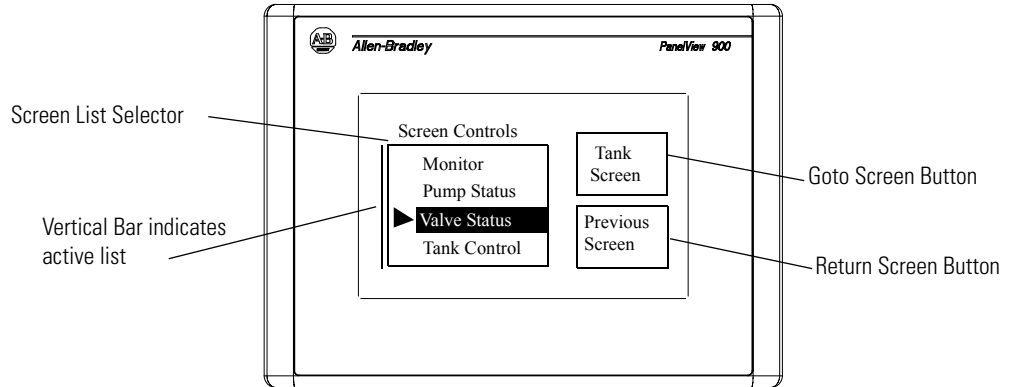

Goto and Return screen buttons can have a variety of appearances such as unique inner text, fill pattern, border or shape. Return screen buttons display the previous screen. Goto screen buttons display the assigned screen.

Screen lists display a list of application screens. The selected screen is highlighted.

To activate a screen list:

- touch the object (touch screen only).
- press the assigned function key.
- press the Left ◀ or Right ▶ arrow key until a vertical bar appears on a screen with multiple screen lists.

Follow these steps to select an item on a screen list.

1. Move the cursor up or down the list by using the Up ▲ or Down ▼ arrow keys.
2. Press Enter ↵ to enter the selection.

The selected screen is displayed.

Cursor Operation

Cursor operation is configured by the application designer. If the cursor is at the first or last item in a screen list, pressing the Up ▲ arrow (when at top) or Down ▼ arrow (when at bottom) will either:

- cause no movement of the cursor
- move the cursor to the top or bottom of the list

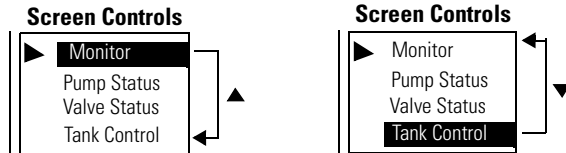

If a screen list contains more items than can appear at one time, the list scrolls. If the cursor is at the top or bottom of a scrolling list, the list scrolls one row at a time as the Up/Down arrows are pressed.

List Keys

Touch screen terminals require list keys on the screen to move the cursor in a screen list and select an entry. The following table shows the list keys.

List Key	Type	Description
▲	Move Up	Moves the cursor to the previous item in the list.
▼	Move Down	Moves the cursor to the next item in the list.
▲	Home	Moves the cursor to the first item in the list.
▼	End	Moves the cursor to the last item in the list.
▲	Page Up	Moves the cursor up one page in a scrolling list.
▼	Page Down	Moves the cursor down one page in a scrolling list.
←	Backspace	Returns the cursor to the currently highlighted selection.
↵	Enter	Confirms a selection and displays the screen.

List Indicators

List indicators highlight an item from a list depending upon the status of either a bit or value at a controller address.

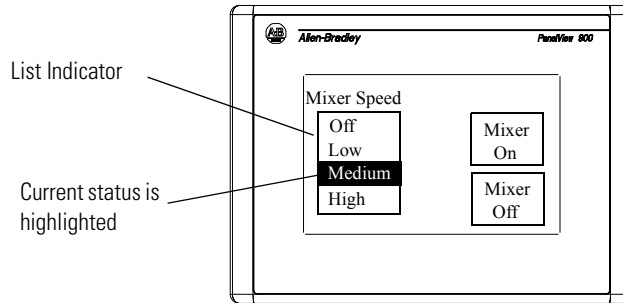

An indicator list may have a maximum of 255 entries. The list automatically scrolls to display the status of an item.

TIP List indicators do not have a cursor ► like control or screen selector lists.

Multistate Indicators

Multistate indicators display the status of either a bit or value at a controller address.

Multistate indicators can have a variety of appearances. In addition, multistate indicators may change their inner text, fill pattern, or graphic with each state (each state assigned different attributes). Each indicator may have up to 2,000 states.



Bar Graph Displays

Bar graphs provide a graphical representation of a variable value. Bar graphs can appear with or without scales and border, and can have a variety of fill patterns.

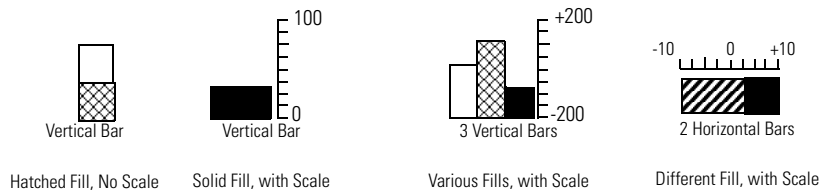

Analog Gauges

The analog gauge uses a rotating needle to display a process variable such as speed, temperature or pressure. The gauge consists of a circular scale with tick-marks, 1... 4 needles, and a label with text or variable data. The circular scale is an integral part of the gauge but can be created separately.

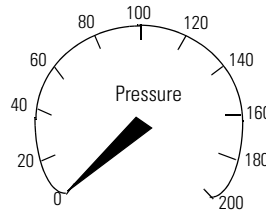

Numeric Data Displays

Numeric Data Displays may appear with or without supporting text.



Depending on the application design, displayed data may have these properties:

- zero fill
- fixed, floating or no decimal point
- different field widths (number of digits)
- various text sizes
- scaled

Message Displays

Message displays contain alphanumeric characters and are displayed when triggered by a controller. The message display can be any size and will not overlap other controls. Messages may contain:

- alphanumeric text
- variable data
- graphics
- time and date

Time or Date

Time and date information can appear as a separate item or in some control/display objects (push buttons, multistate indicators, message displays or data displays). A time and date can appear with or without supporting text.

The date can have a variety of formats.

Month/Day/Year 7/3/01	With Leading Zeroes 07/03/01
Day/Month/Year 3/7/01	With 4 Digit Year 3/7/2001
Year/Month/Day 01/7/3	With User-Defined Separator 7*3*01

The time can also have a variety of formats.

12 Hour Format 2:56	With Time Zone & Time Standard Designations 07/03/00
24 Hour Format 14:56	With Leading Zeroes 02:56
with Seconds 14:56:29	With User-Defined Separator 14*56*29

Printing

Terminals equipped with an RS-232 printer port can print:

- triggered messages in a message display.
- triggered states of a multistate indicator.
- alarm messages.
- alarm list.

Text is printed without formatting options. Print attributes for objects and alarms are defined in the application.

Printing is a background operation. While printing, the terminal continues to update and you can perform other terminal operations.

The terminal prints messages in the order they are received. If the print buffer is full, the terminal displays a queue full warning message. New print requests are aborted.

The print queue is not maintained between power cycles. Any messages in the queue when the terminal is reset are cleared.

Alarms

Applications that support alarms may contain:

- Alarm Banner display that pops up when an alarm is triggered
- Alarm buttons that enable the operator to act on an alarm (Print Alarm, Acknowledge Alarm, Clear Alarm, Acknowledge All)
- Alarm List which stores information on triggered alarms (Print Alarm List or Clear Alarm List button)

Alarm configurations are application dependent. Consult your application designer for details on how to handle alarms for your application.

Installing the PV300 Micro Terminal

Chapter Objectives

This chapter shows how to install the PanelView 300 Micro terminal and covers:

- hazardous locations
- enclosures
- required tools
- mounting dimensions
- clearances
- cutout dimensions
- installing the PV300 micro terminal in a panel

Hazardous Location Considerations

This equipment is suitable for use in Class I, Division 2, Groups A, B, C, D; Class II, Division 2, Groups F, G; Class III; or non-hazardous locations only. The following WARNING statement applies to use in hazardous locations.S

WARNING**EXPLOSION HAZARD**

- Substitution of components may impair suitability for Class I, Class II, Class III, Division 2.
- Do not replace components or disconnect equipment unless power has been switched off or the area is known to be non-hazardous.
- Do not connect or disconnect components unless power has been switched off or the area is known to be non-hazardous.
- This product must be installed in an enclosure. All cables connected to the product must remain in the enclosure or be protected by conduit or other means.
- All wiring must comply with N.E.C. article 501-4(b), 502-4(b), 503-3(b) as appropriate.

See the nameplate on terminal for hazardous locations certifications.

ATTENTION

In Class I, Class II, Class III, Division 2 Hazardous locations, the PanelView terminal must be wired per the National Electric Code as it applies to hazardous locations. Peripheral equipment must also be suitable for the location in which it is installed.

Use only the following communication cables in Class 1, Division 2, Hazardous Locations.

Environmental Classification	Communication Cable
Class I, Division 2, Hazardous Locations	1761-CBL-PM01, Series C
	1761-CBL-HM02, Series C
	1761-CBL-AM00, Series C
	1761-CBL-AP00, Series C
	2711-CBL-PM05, Series C
	2711-CBL-HM05, Series C
	2711-CBL-PM10, Series C
	2711-CBL-HM10, Series C

Enclosures

Mount the PanelView 300 Micro terminal in a panel or enclosure to protect the internal circuitry. The terminal meets NEMA 12/13, 4X (indoor use), IP54 or IP65 ratings only when properly mounted in a panel or enclosure with the equivalent rating. Allow enough space within the enclosure for adequate ventilation. Consider heat produced by other devices in the enclosure. The ambient temperature around the PanelView 300 Micro terminal must be° between 0...55 °C (32...131 °F).

Make provisions for accessing the side panel of the terminal for wiring, maintenance and troubleshooting.

Required Tools

Other than the tools required to make panel or enclosure cutouts, these tools are required for installation.

- 7 mm (M4) deep-well socket wrench or nut driver
- small slotted screwdriver
- torque wrench (lb-in)

Mounting Dimensions

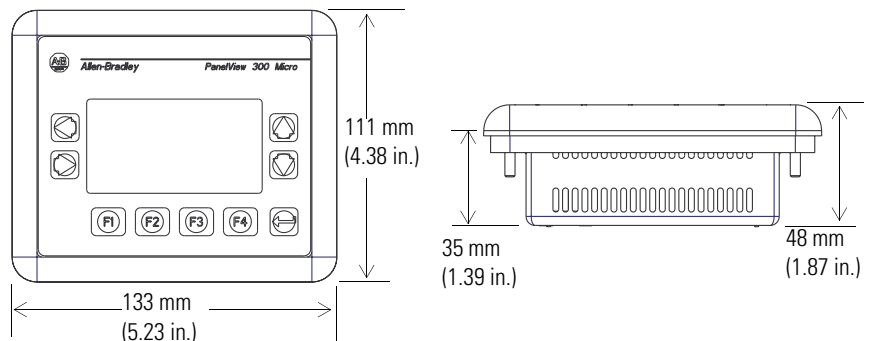

Cutout Dimensions

Use the full size template shipped with the PV300 Micro terminal to mark the cutout dimensions. The figure below shows a reduced scale cutout. A full scale template is also available inside the back cover of this document.

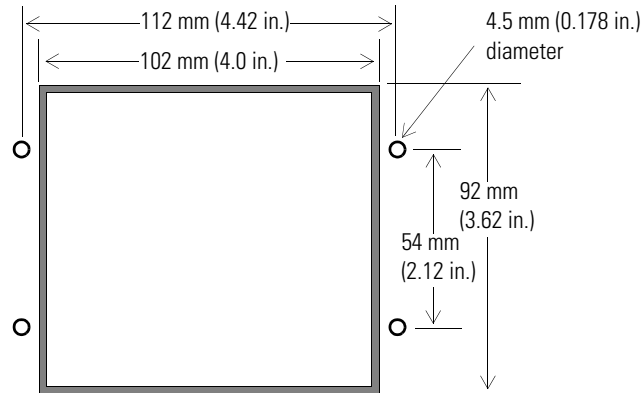

Clearances

Allow 51 mm (2.0 in.) of space on all sides of the terminal for adequate ventilation and maintenance.

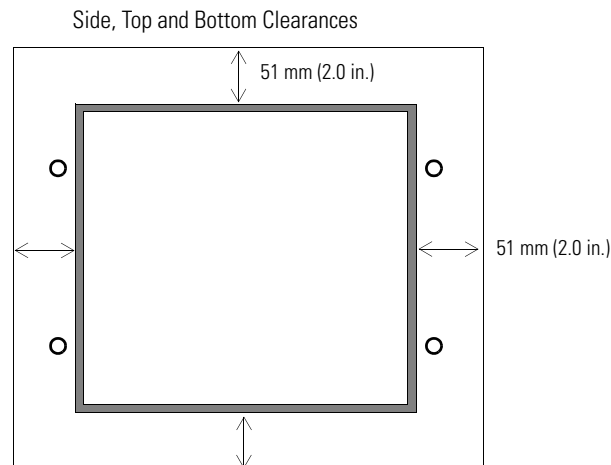

Install Terminal in Panel

Follow these steps to install the PV300 Micro in a panel.

ATTENTION



- Disconnect all electrical power from the panel before making cutout.
- Make sure area around the panel cutout is clear.
- Take precautions so that metal cuttings do not enter any components already installed in panel.
- Failure to follow this warning may result in personal injury or damage to the panel components.

1. Cut an opening in the panel by using the panel cutout template provided with the terminal and remove sharp edges or burrs.
2. Make sure the sealing gasket is properly positioned on the terminal, particularly around the mounting studs as shown.

This gasket forms a compression type seal. Do not use sealing compounds.

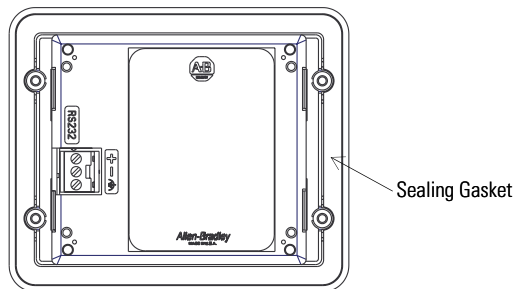

3. Place the terminal in the panel cutout.
4. Install the four self-locking nuts, and tighten hand tight.

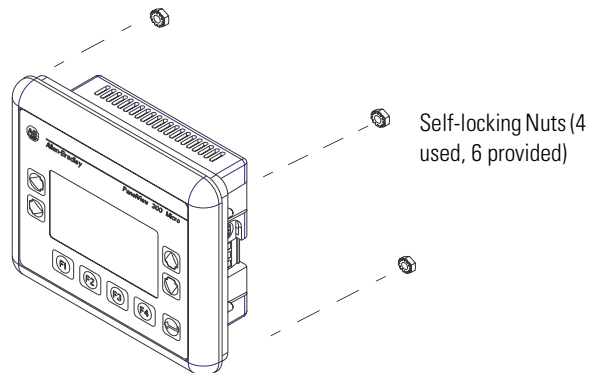

5. Alternately tighten the self-locking nuts until the terminal is held firmly against the panel.

6. Tighten the nuts to a torque of 1.13 Nm (10 lb-in).

Do not overtighten.

ATTENTION



Mounting nuts must be tightened to a torque of 1.13 Nm (10 lb-in) to provide a proper seal and to prevent potential damage to the terminal. Allen-Bradley assumes no responsibility for water or chemical damage to the terminal or other equipment within the enclosure because of improper installation. A properly installed terminal has a small gap between the bezel and enclosure.

Installing the PV300 Terminal

Chapter Objectives

This chapter shows how to install the PanelView 300 terminal and covers:

- hazardous locations.
- enclosures.
- required tools.
- mounting dimensions.
- clearances.
- cutout dimensions.
- installing the PV300 terminal in a panel.

Hazardous Location Considerations

This equipment is suitable for use in Class I, Division 2, Groups A, B, C, D; Class II, Division 2, Groups F and G; Class III; or non-hazardous locations only. The following WARNING statement applies to use in hazardous locations.

WARNING**EXPLOSION HAZARD**

- Substitution of components may impair suitability for Class I, Class II, Class III Division 2.
- Do not replace components or disconnect equipment unless power has been switched off or the area is known to be non-hazardous.
- Do not connect or disconnect components unless power has been switched off or the area is known to be non-hazardous.
- This product must be installed in an enclosure. All cables connected to the product must remain in the enclosure or be protected by conduit or other means.
- All wiring must comply with N.E.C. article 501-4(b), 502-4(b), 503-3(b) as appropriate.

See the nameplate on terminal for hazardous locations certifications.

ATTENTION

In Class I, Class II, Class III Division 2 Hazardous locations, the PanelView terminal must be wired per the National Electric Code as it applies to hazardous locations. Peripheral equipment must also be suitable for the location in which it is installed.

The PV300 terminals have an operating temperature code of T4 (maximum operating temperature of 135 °C or 275 °F). **Do not** install these terminals in environments where atmospheric gases have ignition temperatures less than 135 °C (275 °F).

Enclosures

Mount the PV300 terminal in a panel or enclosure to protect the internal circuitry. The terminal meets NEMA Type 12/13 and 4X (indoor use) ratings only when mounted in a panel or enclosure with the equivalent rating.

Allow enough space within the enclosure for adequate ventilation. Consider heat produced by other devices in the enclosure. The ambient temperature around the terminals must be between 0...55 °C (32...131 °F).

Make provisions to access the back panel of the terminal for wiring, maintenance, installing a memory card and troubleshooting.

Required Tools

Other than the tools required to make the PV300 panel cutout, the tools required for installation are:

- 7 mm (M4) deep well socket wrench or nut driver
- small slotted screwdriver
- torque wrench (lb-in)

Mounting Dimensions

The illustration below shows mounting dimensions for the PV300 keypad terminals.

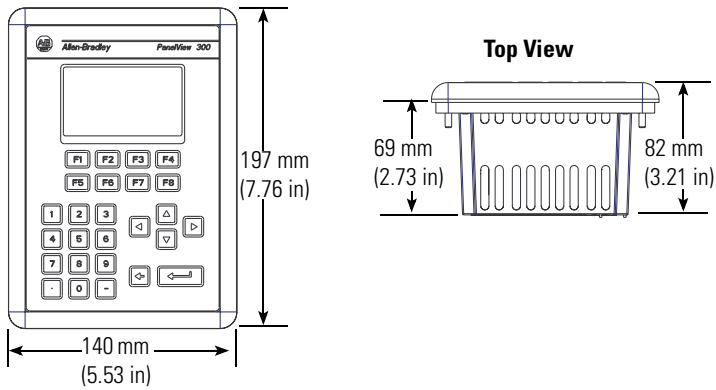

Cutout Dimensions

Use the full size template shipped with the PV300 terminal to mark the cutout dimensions. Below is a reduce size cutout.

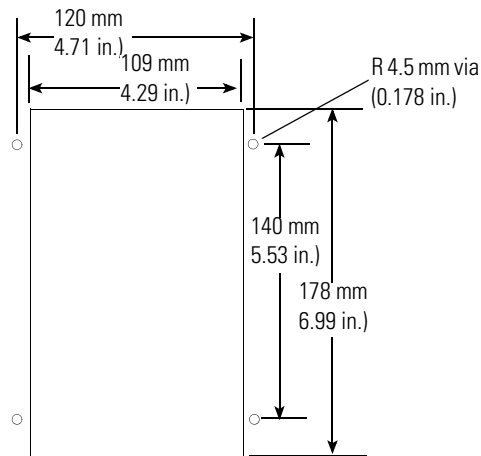

Clearances

When installing the PV300 terminal, allow space for mounting, air flow, maintenance, memory card and legend strip installation.

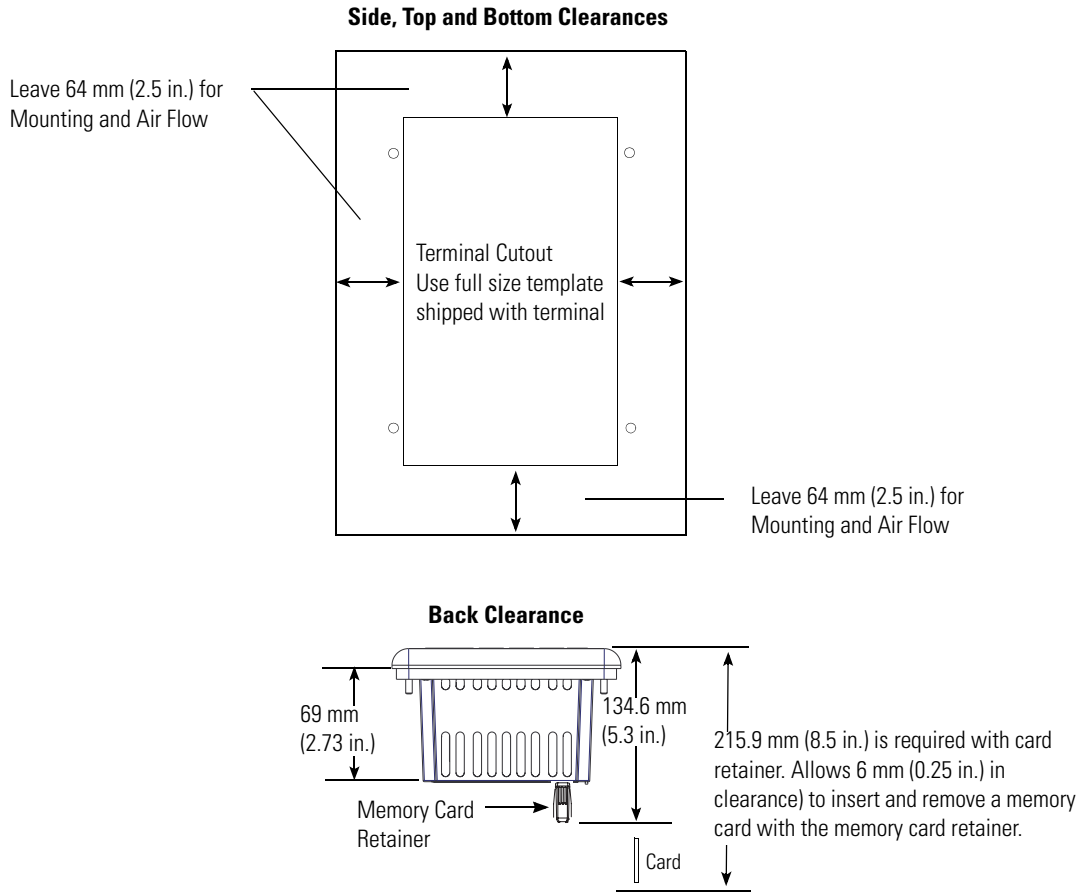

Install the PV300 Terminal in a Panel

Follow these steps to install the PV300 terminal in a panel.

ATTENTION



- Disconnect all electrical power from the panel before making the cutout.
- Make sure the area around the panel cutout is clear.
- Do not allow metal cuttings to enter any components that may already be installed in the panel.
- Failure to follow this warning may result in personal injury or damage to the panel components.

1. Cut an opening in the panel by using the panel cutout template provided with the terminal and remove any sharp edges or burrs.
2. Make sure the terminal sealing gasket is properly positioned on the terminal, particularly around the mounting studs as shown. ■

This gasket forms a compression type seal. Do not use sealing compounds.

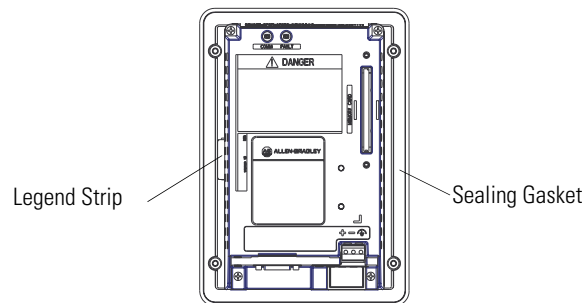

3. Verify that the end of the legend strip is fully inserted and does not interfere with the sealing gasket.
4. Place the terminal in the panel cutout.
5. Verify that the opening is the proper size to clear the bezel and to allow the gasket to contact the panel.

6. Install the self-locking nuts hand tight.

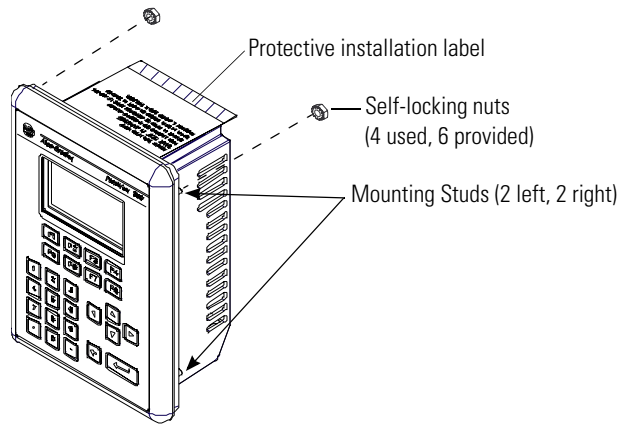

7. Alternately tighten the self-locking nuts until the terminal is held firmly against the panel
8. Tighten the nuts to a torque of 1.13 Nm (10 lb-in).

Do not over-tighten.

ATTENTION



Mounting nuts must be tightened to a torque of 1.13 Nm (10 lb-in) to provide a proper seal and to prevent potential damage to the terminal. Allen-Bradley assumes no responsibility for water or chemical damage to the terminal or other equipment within the enclosure because of improper installation. A properly installed terminal has a small gap between the bezel and enclosure.

-
9. Remove the protective installation label covering the top vents of the terminal.

ATTENTION



Failure to remove the protective installation label covering the top vents could result in overheating and damage to the terminal.

Installing the PV550 Terminal

Chapter Objectives

This chapter describes how to mount the PV550 terminal in a panel or enclosure including:

- hazardous locations
- enclosures
- required tools
- mounting dimensions
- clearances
- cutout dimensions
- installing the PV550 terminal in a panel

Hazardous Location Considerations

This equipment is suitable for use in Class I, Division 2, Groups A, B, C, D or non-hazardous locations only. Keypad Series H, Keypad/touch Series H, and touch-only Series B are also rated Class II, Division 2, Groups F, G, Class III, or non-hazardous locations only. The following WARNING statement applies to use in hazardous locations.

WARNING**EXPLOSION HAZARD**

- Substitution of components may impair suitability for Class I, Class II, Class III, Division 2.
- Do not replace components or disconnect equipment unless power has been switched off or the area is known to be non-hazardous.
- Do not connect or disconnect components unless power has been switched off or the area is known to be non-hazardous.
- This product must be installed in an enclosure. All cables connected to the product must remain in the enclosure or be protected by conduit or other means.
- All wiring must comply with N.E.C. article 501-4(b), 502-4(b), 503-3(b) as appropriate.

See the nameplate label on terminal for hazardous locations certifications.

ATTENTION

In Class I, Class II, Class III, Division 2 Hazardous locations, the PanelView 550 terminal must be wired per the National Electric Code as it applies to hazardous locations. Peripheral equipment must also be suitable for the location in which it is installed.

The following PV550 terminals have an operating temperature code of T2 (maximum operating temperature of 300 °C or 572 °F).

- keypad terminals (series G or earlier)
- keypad and touch screen terminals (series G or earlier)
- touch screen only terminals (series A)

Do not install these terminals in environments where atmospheric gases have ignition temperatures less than 300 °C (572 °F).

The following PV550 following PV550 terminals have an operating temperature code of T4 (maximum operating temperature of 135 °C or 275 °F).

- keypad terminals (series H and later)
- keypad and touch screen terminals (series H and later)
- touch screen only terminals (series B and later)

Do not install these terminals in environments where atmospheric gases have ignition temperatures less than 135 °C (275 °F).

Enclosures

Mount the PV550 terminal in a panel or enclosure to protect the internal circuitry. The terminal meets NEMA Type 12/13 and 4X (indoor use) ratings only when mounted in a panel or enclosure with the equivalent rating.

Allow enough space within the enclosure for adequate ventilation. Consider heat produced by other devices in the enclosure. The ambient temperature around the terminals must be between 0... 55 °C (32...131 °F).

Make provisions to access the back panel of the terminal for wiring, maintenance, installing a memory card and troubleshooting.

Required Tools

Other than the tools required to make the PV550 panel cutout, the tools required for installation are:

- 7 mm (M4) deep well socket wrench or nut driver
- small slotted screwdriver
- torque wrench (lb-in)

Mounting Dimensions

The illustration below shows mounting dimensions for the PV550 terminals.

PV550 Keypad, Keypad & Touch Screen Terminals

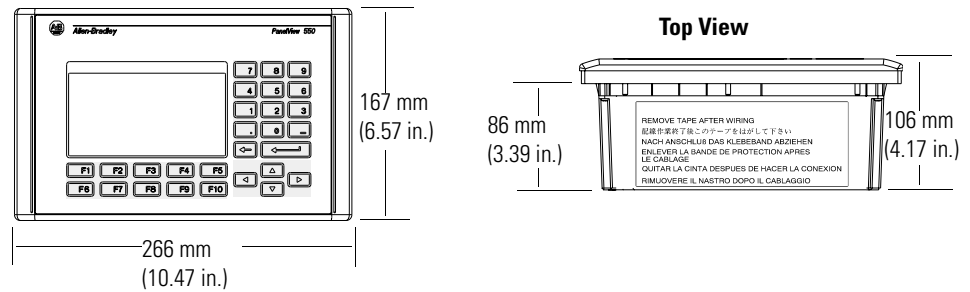

PV550 Touch Screen Terminals

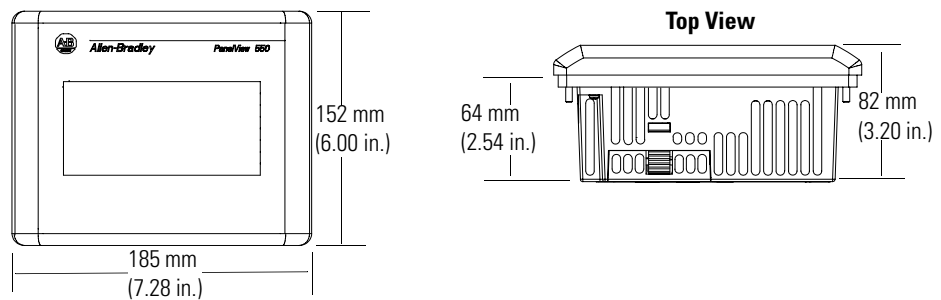

Clearances

When installing the PV550 terminal, allow space for mounting, air flow, maintenance, memory card and legend strip installation.

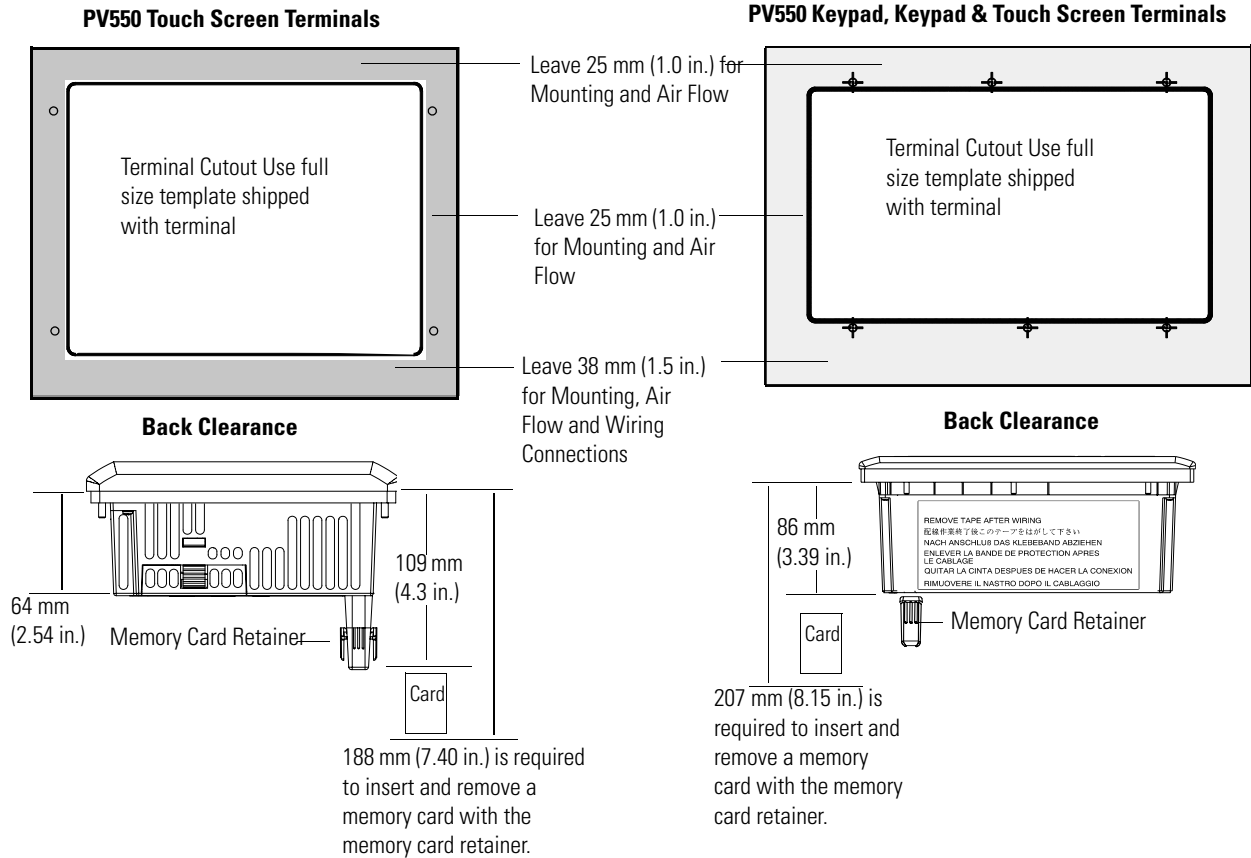

Cutout Dimensions

Use the full size template shipped with the PV550 terminal to mark the cutout dimensions. Below is a reduce size cutout.

PV550 Keypad, Keypad and Touch Screen Terminals

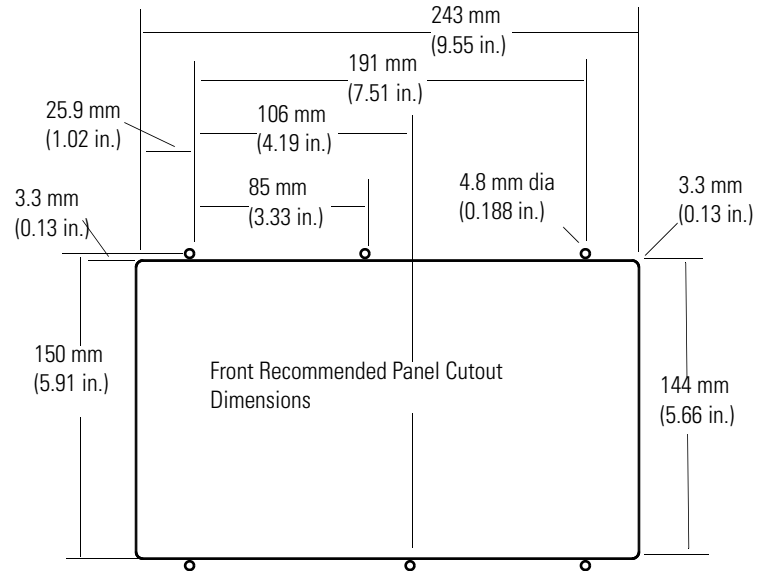

PV550 Touch Screen Terminals

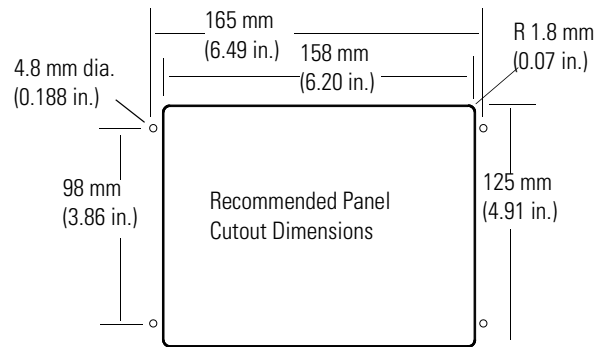

Install the PV550 Terminal in a Panel

Follow these step to install the PV550 terminal in a panel.

ATTENTION



- Disconnect all electrical power from the panel before making the cutout.
- Make sure the area around the panel cutout is clear.
- Do not allow metal cuttings to enter any components that may already be installed in the panel.
- Failure to follow this warning may result in personal injury or damage to the panel components.

1. Cut an opening in the panel by using the panel cutout template provided with the terminal and remove any sharp edges or burrs.
2. Make sure the terminal sealing gasket is properly positioned on the terminal, particularly around the mounting studs as shown.

This gasket forms a compression type seal. Do not use sealing compounds.

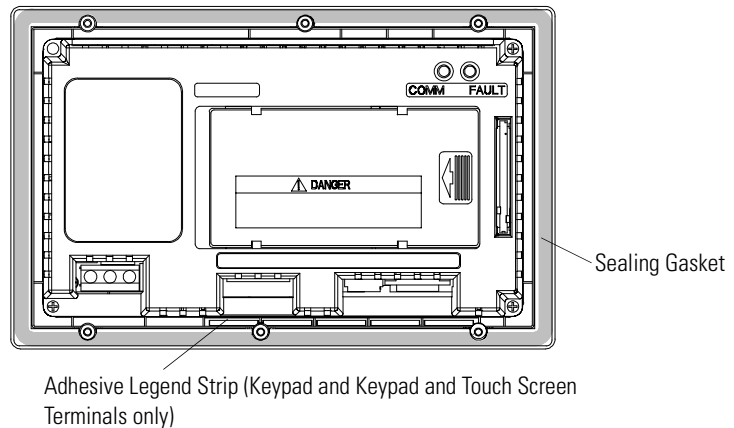

3. On the keypad and keypad and touch screen terminals, secure the ends of the legend strips to the legend strip adhesive.
4. Place the terminal in the panel cutout.
5. Verify that the opening is the proper size to clear the bezel and to allow the gasket to contact the panel.
6. On the keypad and keypad and touch screen terminals, position the ends of the legend inserts behind the panel cutout.
7. Install the self-locking nuts hand tight.

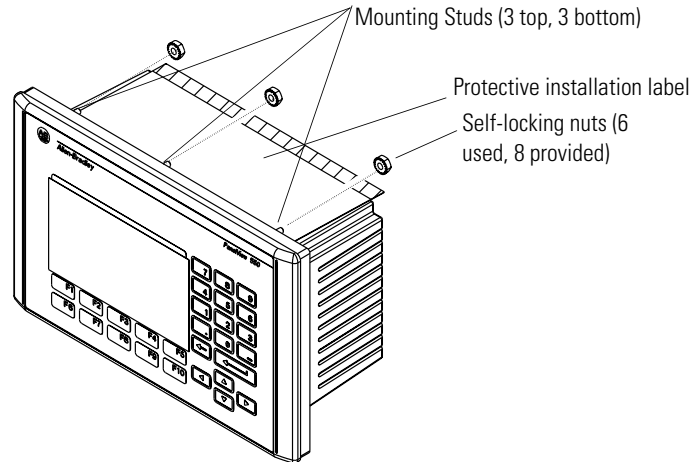
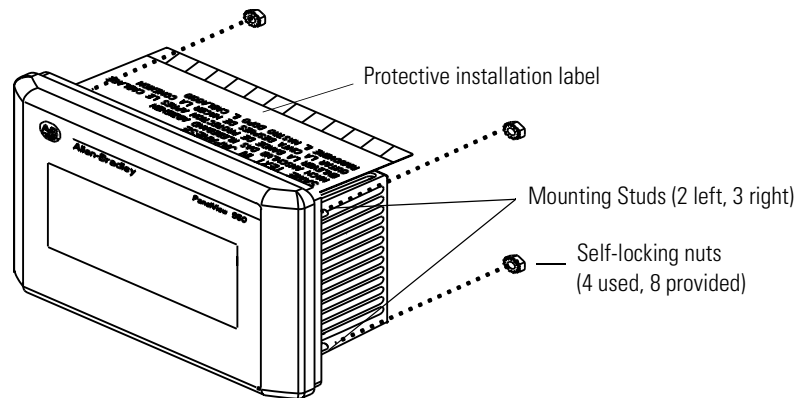
PV550 Keypad, Keypad & Touch Screen Terminals**PV550 Touch Screen Terminal**

8. Alternately tighten the self-locking nuts until the terminal is held firmly against the panel.
9. Tighten nuts to a torque of 1.13 Nm (10 lb-in).

Do not over-tighten.

ATTENTION

Mounting nuts must be tightened to a torque of 1.13 Nm (10 lb-in) to provide a proper seal and to prevent potential damage to the terminal. Allen-Bradley assumes no responsibility for water or chemical damage to the terminal or other equipment within the enclosure because of improper installation. A properly installed terminal has a small gap between the bezel and enclosure.

10. Remove protective installation label from top vents of terminal.

ATTENTION



Failure to remove the protective installation label covering the top vents could result in overheating and damage to the terminal.

Installing the PV600 Terminal

Chapter Objectives

This chapter describes how to mount the PV600 terminal in a panel or enclosure including:

- hazardous locations
- enclosures
- required tools
- mounting dimensions
- cutout dimensions
- clearances
- installing the PV600 terminal in a panel

Hazardous Location Considerations

This equipment is suitable for use in Class I, Division 2, Groups A, B, C, D; Class II, Division 2, Groups F, G; Class III; or non-hazardous locations only. The following WARNING statement applies to use in hazardous locations.

WARNING



EXPLOSION HAZARD

- Substitution of components may impair suitability for Class I, Class II, Class III, Division 2.
- Do not replace components or disconnect equipment unless power has been switched off or the area is known to be non-hazardous.
- Do not connect or disconnect components unless power has been switched off or the area is known to be non-hazardous.
- This product must be installed in an enclosure. All cables connected to the product must remain in the enclosure or be protected by conduit or other means.
- All wiring must comply with N.E.C. article 501-4(b), 502-4(b), 503-3(b) as appropriate.

See the nameplate label on terminal for certifications on hazardous locations.

ATTENTION



In Class I, Class II, Class III, Division 2 Hazardous locations, the PanelView terminal must be wired per the National Electric Code as it applies to hazardous locations. Peripheral equipment must also be suitable for the location in which it is installed.

The PV600 terminals have an operating temperature code of T4 (maximum operating temperature of 135 °C or 275 °F). **Do not** install the terminals in environments where atmospheric gases have ignition temperatures less than 135 °C (275 °F).

Enclosures

Mount the PV600 terminal in a panel or enclosure to protect the internal circuitry. The terminal meets NEMA Type 12/13 and 4X (indoor use) ratings only when mounted in a panel or enclosure with the equivalent rating.

Allow enough space within the enclosure for adequate ventilation. Consider heat produced by other devices in the enclosure. The ambient temperature around the terminals must be between:

- 0...55 °C (32...131 °F) for the PV600 keypad or keypad & touch screen terminal
- 0...50 °C (32...122 °F) for the PV600 touch screen only terminal

Make provisions to access the back panel of the terminal for wiring, maintenance, installing a memory card and troubleshooting.

Required Tools

Other than the tools required to make the PV600 panel cutout, the tools required for installation are:

- small slotted screwdriver
- torque wrench (lb-in)
- #2 phillips screwdriver
- #2 phillips bit for torque wrench

Mounting Dimensions

The illustration below shows mounting dimensions for the PV600 terminals.

PV600 Keypad, Keypad and Touch Screen Terminals

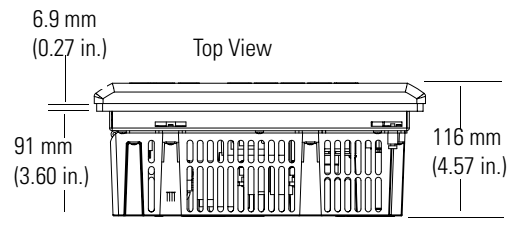
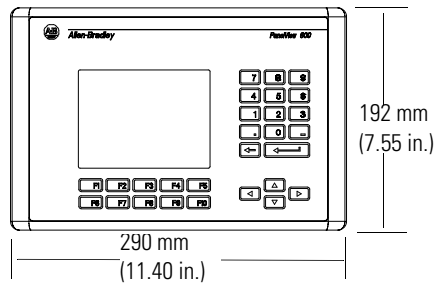

PV600 Touch Screen Terminals

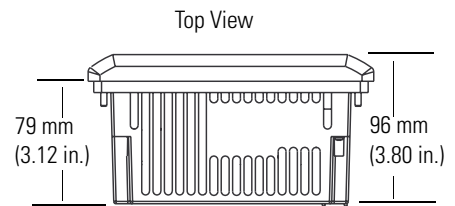
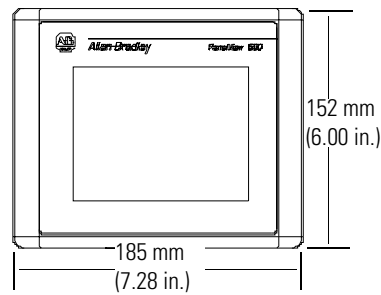

Cutout Dimensions

Use the full size template shipped with the PV600 terminal to mark the cutout dimensions. Below is a reduce size cutout.

PV600 Keypad, Keypad and Touch Screen Terminals

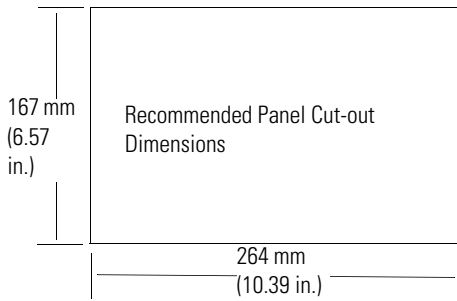

PV600 Touch Screen Terminals

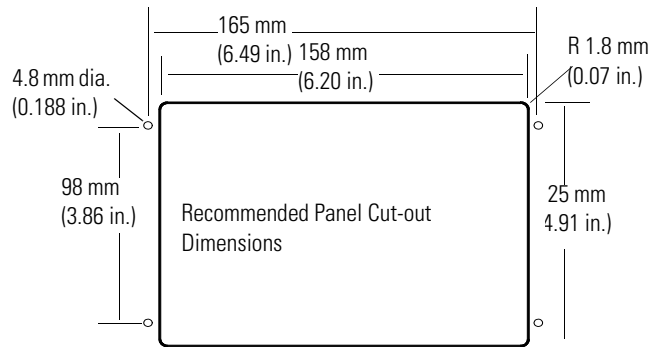

Clearances

When installing the PV600 terminal, allow adequate space for mounting, air flow, maintenance, memory card and legend strip installation.

PV600 Keypad and Keypad and Touch Screen Terminals

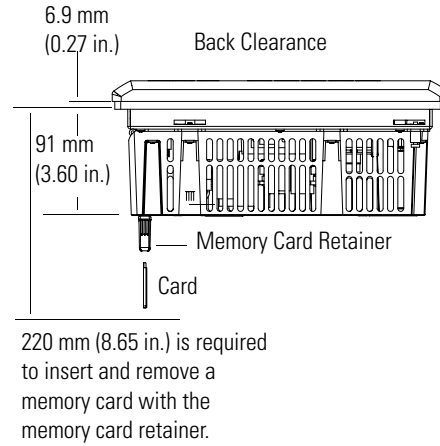
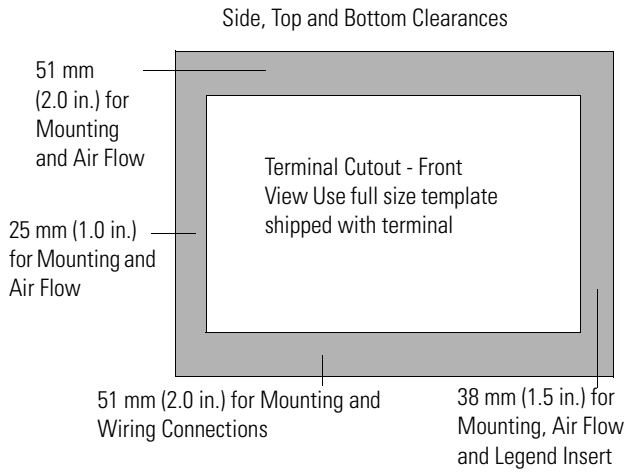

PV600 Touch Screen Terminals

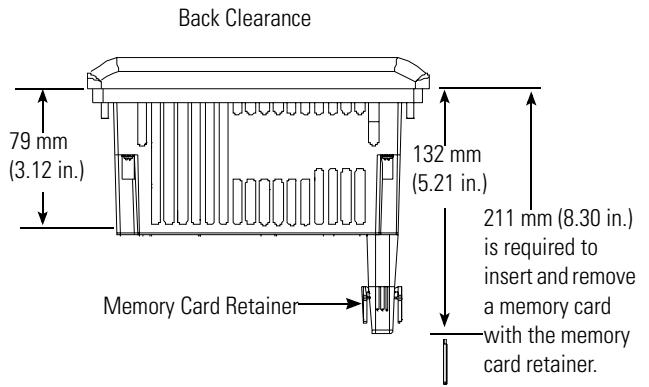
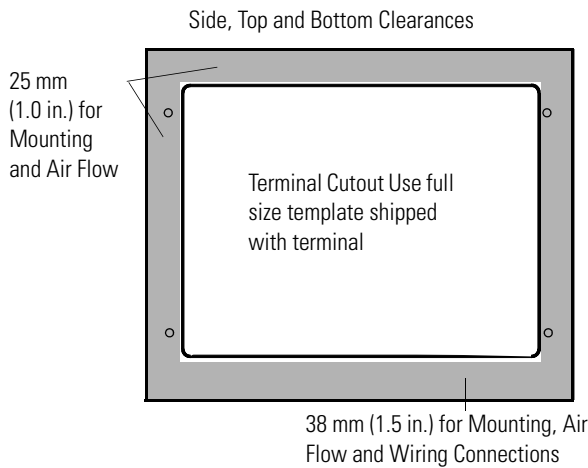

Install the PV600 in a Panel

To install the PV600 terminal in a panel:

ATTENTION



- Disconnect all electrical power from the panel before making the cutout.
- Make sure the area around the panel cutout is clear.
- Do not allow metal cuttings to enter any components that may already be installed in the panel.
- Failure to follow this warning may result in personal injury or damage to the panel components.

1. Cut an opening in the panel by using the panel cutout template provided with the terminal and remove any sharp edges or burrs.
2. Make sure the terminal sealing gasket is properly positioned on the terminal, particularly around the mounting studs as shown.

This gasket forms a compression type seal. Do not use sealing compounds.

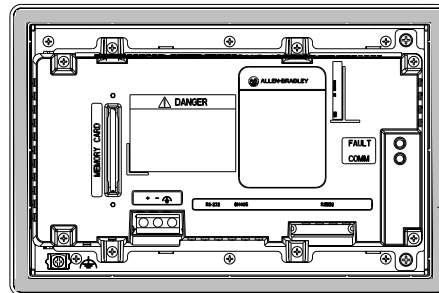

Although the keypad legend strip can be installed on the keypad and keypad & touch screen terminals at any time, we recommend that you install the strip after the terminal is installed.

3. Place the terminal in the panel cutout.

4. Install the 4 mounting clips (2 on top, 2 on bottom).

The ends of the clips slide into the slots on the terminal.

5. Tighten the clip mounting screws by hand until the gasket seal contacts the mounting surface uniformly.

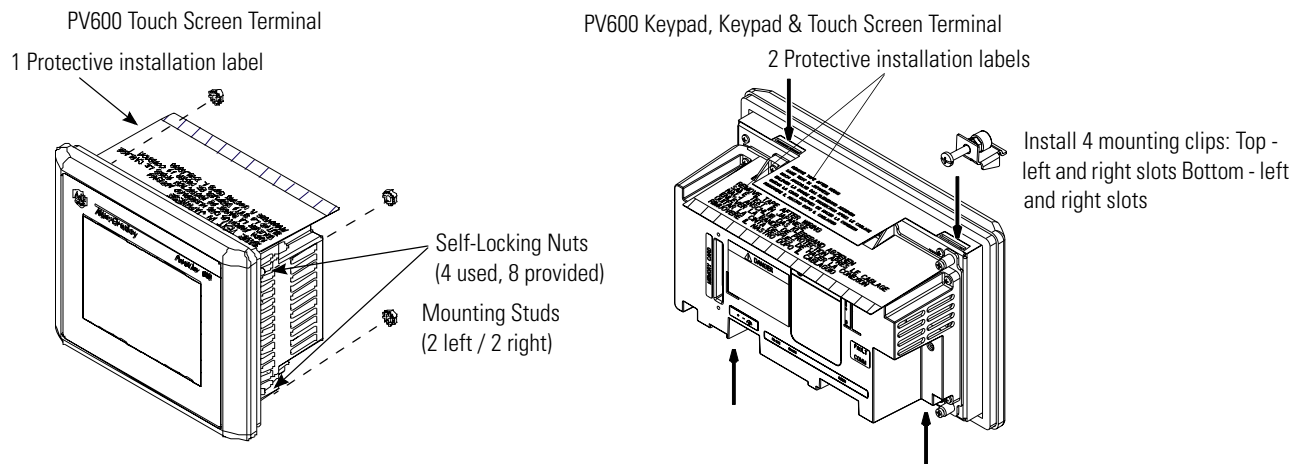

6. Alternately tighten the self-locking nuts or mounting clip screws until the terminal is held firmly against the panel.
7. Tighten the nuts or screws to a torque of 1.13 Nm (10 lb-in).

Do not over-tighten.

ATTENTION

Mounting nuts must be tightened to a torque of 1.13 Nm (10 lb-in) to provide a proper seal and to prevent potential damage to the terminal. Allen-Bradley assumes no responsibility for water or chemical damage to the terminal or other equipment within the enclosure because of improper installation. A properly installed terminal has a small gap between the bezel and enclosure.

8. Remove protective installation labels over top vents of terminal.

ATTENTION

Failure to remove the protective installation label covering the top vents could result in overheating and damage to the terminal.

Installing the PV900/1000 Terminals

Chapter Objectives

This chapter describes how to mount the PV900 and PV1000 terminals in a panel or enclosure including:

- hazardous locations and enclosures
- required tools
- mounting dimensions
- clearances
- cutout dimensions
- installing the PV900/PV1000 terminal in a panel

Hazardous Location Considerations

This equipment is suitable for use in Class I, Division 2, Groups A, B, C, D; or non-hazardous locations only. PV 1000 terminals are also suitable for use in Class II, Division 2, Groups F, G, Class III, or non-hazardous locations. The following WARNING statement applies to use in hazardous locations.

WARNING**EXPLOSION HAZARD**

- Substitution of components may impair suitability for Class I, Class II, Class III Division 2.
- Do not replace components or disconnect equipment unless power has been switched off or the area is known to be non-hazardous.
- Do not connect or disconnect components unless power has been switched off or the area is known to be non-hazardous.
- This product must be installed in an enclosure. All cables connected to the product must remain in the enclosure or be protected by conduit or other means.
- All wiring must comply with N.E.C. article 501-4(b), 502-4(b), 503-3(b) as appropriate.

See the nameplate on terminal for hazardous locations certifications.

ATTENTION

In Class I, Class II, Class III Division 2 Hazardous locations, the PanelView 900/1000 terminals must be wired per the National Electric Code as it applies to hazardous locations. Peripheral equipment must also be suitable for the location in which it is installed.

The PV900/PV1000 terminals have an operating temperature code of T4 (maximum operating temperature of 135 °C or 275 °F). **Do not** install the terminals in environments where atmospheric gases have ignition temperatures less than 135 °C (275 °F).

Enclosures

The PV900/PV1000 terminal must be mounted in an environment that provides IEC-1131-2 Pollution degree 2 protection.

Mount the terminal in a panel or enclosure to protect the internal circuitry. The terminal meets NEMA Type 12/13 and 4X (indoor use) ratings only when mounted in a panel or enclosure with the equivalent rating.

Allow enough space within the enclosure for adequate ventilation. Consider heat produced by other devices in the enclosure. The ambient temperature around the terminals must be between 0...55 °C (32...131 °F).

Required Tools

Other than the tools required to make the panel cutout, the tools required for installation are:

- small slotted screwdriver
- torque wrench (lb-in) with slotted or phillips head driver

PV900 Terminals Mounting Dimensions

IMPORTANT

PanelView 900 terminals are no longer available. Contact your local sales office or authorized Rockwell Distributor for suitable substitutes.

The illustrations below show mounting dimensions for the PV900 monochrome and color terminals.

PV900 Touch Terminal Mounting Dimensions

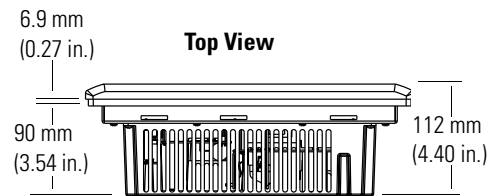
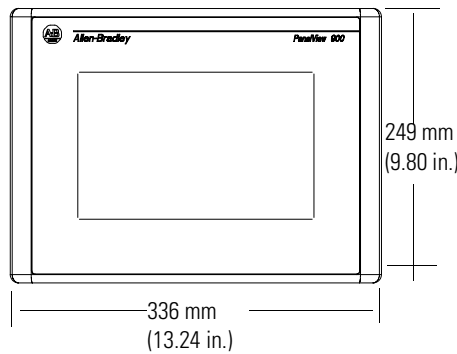

PV900 Keypad Terminal Mounting Dimensions

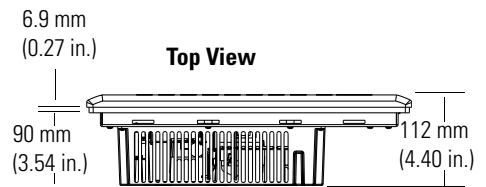
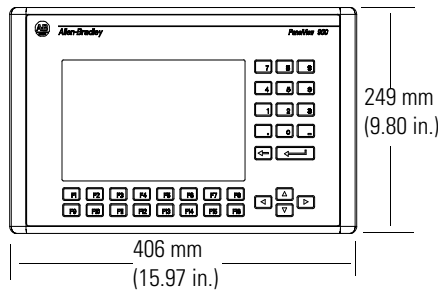

PV1000 Terminals Mounting Dimensions

The illustrations below show the mounting dimensions for the PV1000 grayscale and color terminals.

PV1000 Touch Terminal Mounting Dimensions

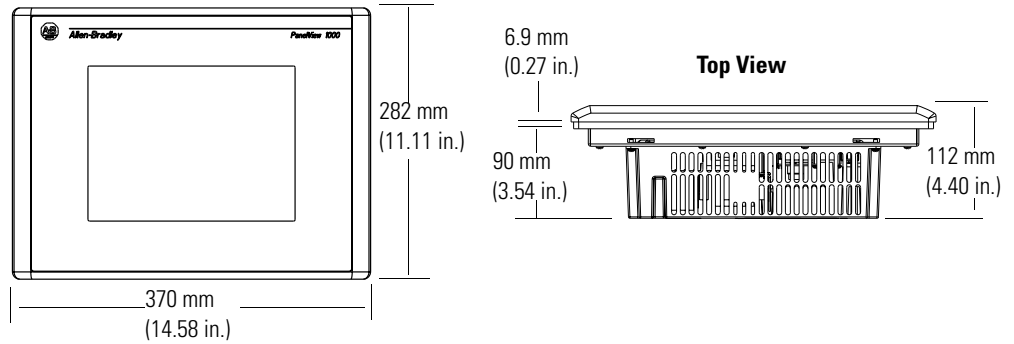

PV1000 Keypad Terminal Mounting Dimensions

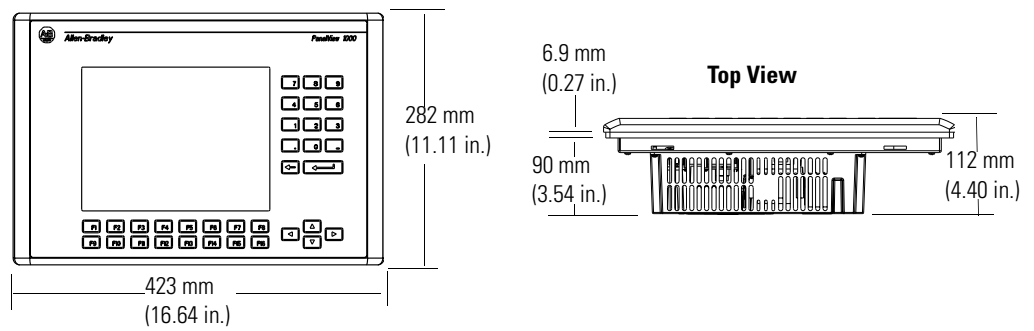

Clearances

Allow adequate space for mounting, air flow, maintenance, memory card and legend strip installation.

IMPORTANT

If using a memory card and/or memory card retainer, allow a back clearance to load the card.

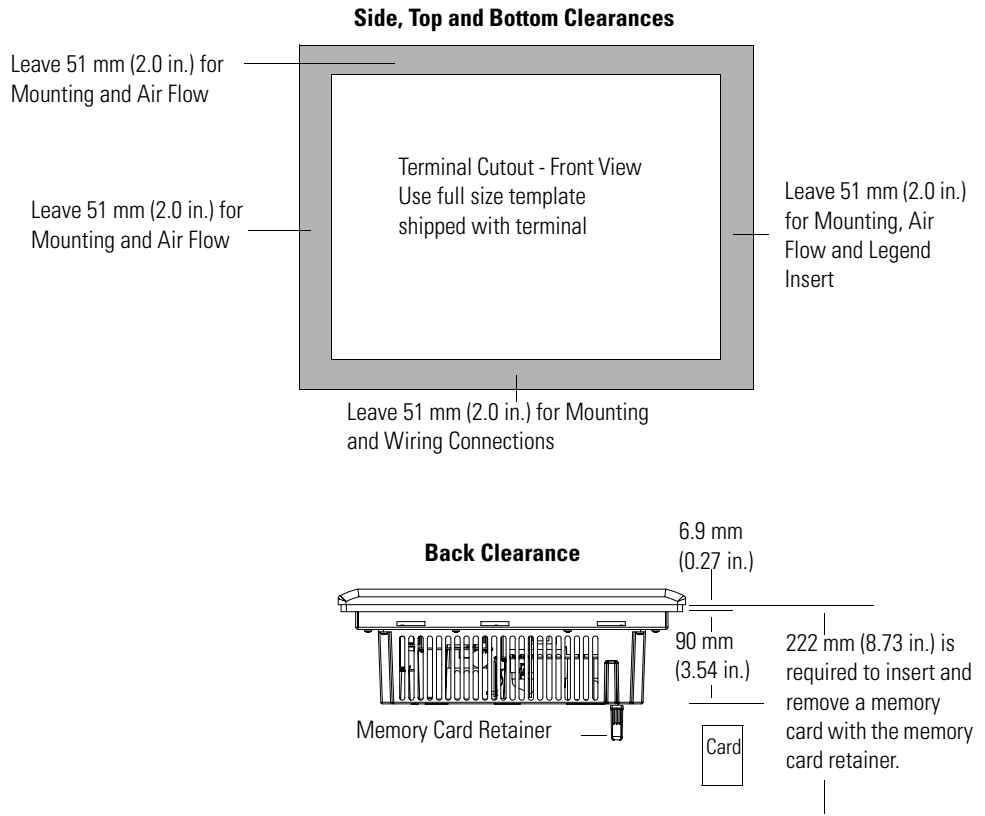

Cutout Dimensions

Use the full size template shipped with the PV900 and PV1000 terminals to mark the cutout dimensions. The following illustrations show reduced cutouts for these terminals with dimensions.

PV900 Panel Cutout Dimensions

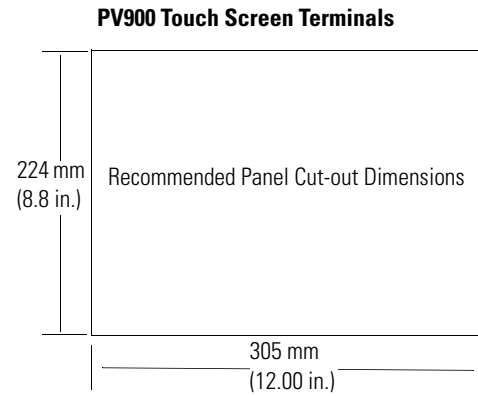
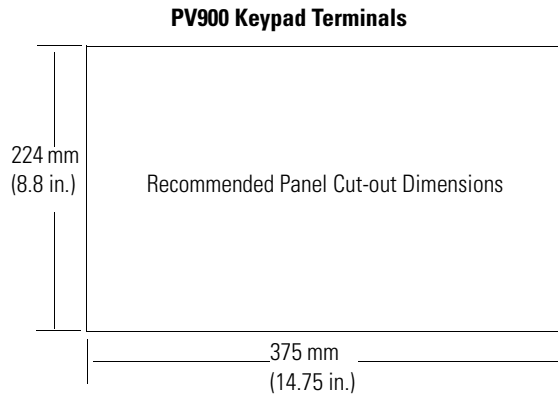

PV1000 Panel Cutout Dimensions

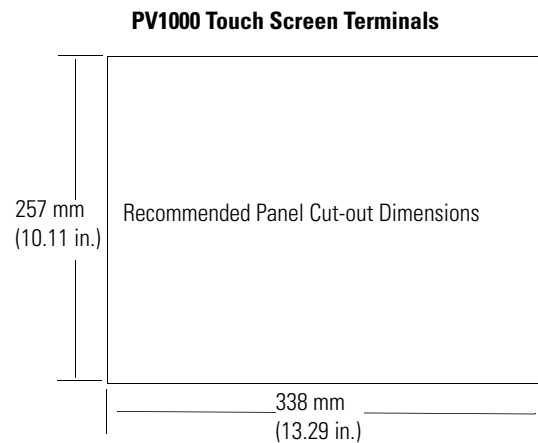
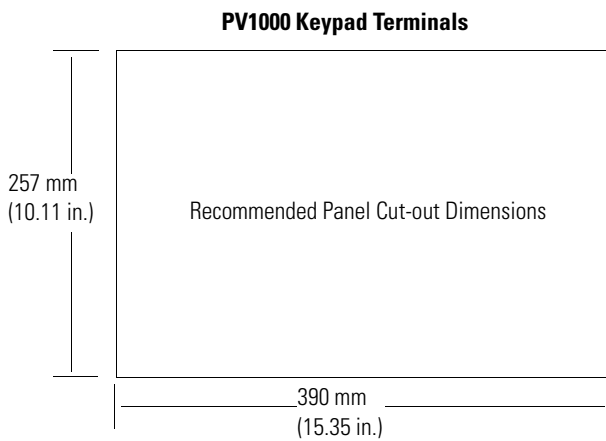

Install the PV900/PV1000 Terminals in a Panel

Follow these steps to install the PV900/PV1000 terminal in a panel.

ATTENTION



- Disconnect all electrical power from the panel before making the cutout.
- Make sure the area around the panel cutout is clear.
- Do not allow metal cuttings to enter any components that may already be installed in the panel.
- Failure to follow this warning may result in personal injury or damage to the panel components.

1. Cut an opening in the panel by using the panel cutout template provided with the terminal and remove any sharp edges or burrs.
2. Make sure the terminal sealing gasket is properly positioned on the terminal, particularly around the mounting studs as shown. ■

This gasket forms a compression type seal. Do not use sealing compounds.

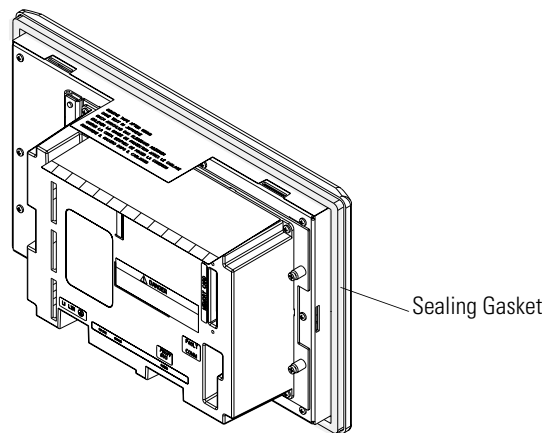

Although the keypad legend strip can be installed any time, we recommend that you install it after the terminal is installed.

3. Place the terminal in the panel cutout.

4. Install the 6 mounting clips (2 on top, 2 on bottom, 1 on each side).

The ends of the clips slide into the slots on the terminal.

5. Tighten the clip mounting screws by hand until the gasket seal contacts the mounting surface uniformly.

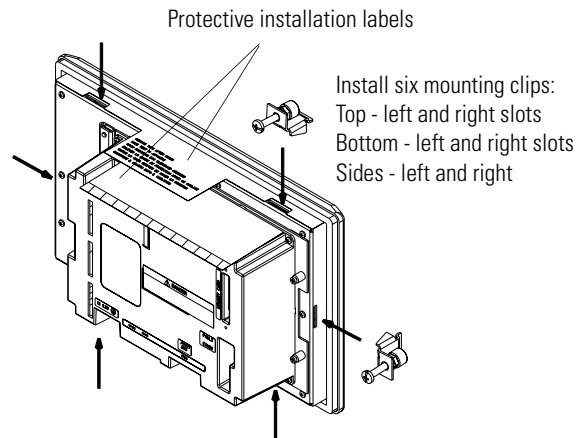

6. Alternately tighten the mounting clip screws to a torque of 1.13 Nm (10 lb-in).

Do not over-tighten.

ATTENTION



Mounting nuts must be tightened to a torque of 1.13 Nm (10 lb-in) to provide a proper seal and to prevent potential damage to the terminal. Allen-Bradley assumes no responsibility for water or chemical damage to the terminal or other equipment within the enclosure because of improper installation. A properly installed terminal has a small gap between the bezel and enclosure.

7. Remove the two protective labels covering the top vents of the terminal.

ATTENTION



Failure to remove the protective installation label covering the top vents could result in overheating and damage to the terminal.

Installing the PV1400 Terminal

Chapter Objectives

IMPORTANT

PanelView 1400 terminals are no longer available. Contact your local sales office or authorized Rockwell Distributor for suitable substitutes.

This chapter describes how to mount the PV1400 terminal in a panel or enclosure including:

- enclosures
- recommended tools
- mounting dimensions
- clearances
- cutout dimensions
- installing the PV1400 terminal in a panel

Enclosures

The PV1400 terminal must be mounted in an environment that provides IEC-1131-2 Pollution degree 2 protection.

Mount the PV1400 terminal in a panel or enclosure to protect the internal circuitry. The terminal meets NEMA Type 12/13 and 4X (indoor use) ratings only when mounted in a panel or enclosure with the equivalent rating.

Allow enough space within the enclosure for adequate ventilation. Consider heat produced by other devices in the enclosure. The ambient temperature around the terminals must be between 0...55 °C (32...131 °F).

Make provisions to access the back sides of the terminal. Access is required for wiring, routine maintenance, adjusting brightness/contrast, installing a memory card and troubleshooting.

Required Tools

In addition to the tools required to make the panel cutout, you need the tools below.

For clip mounting:

- socket screwdriver (Phillips head or slotted)
- 406 mm (16 in.) extension rod (minimum)
- socket driver (in/lab torque wrench recommended)

For stud mounting:

- 7/32 and 3/8 in. socket
- 406 mm (16 in.) extension rod (minimum)
- socket driver (1b-in torque wrench recommended)

Mounting Dimensions

The illustrations below show mounting dimensions for the PV1400 terminals.

PV1400 Touch Terminal Mounting Dimensions

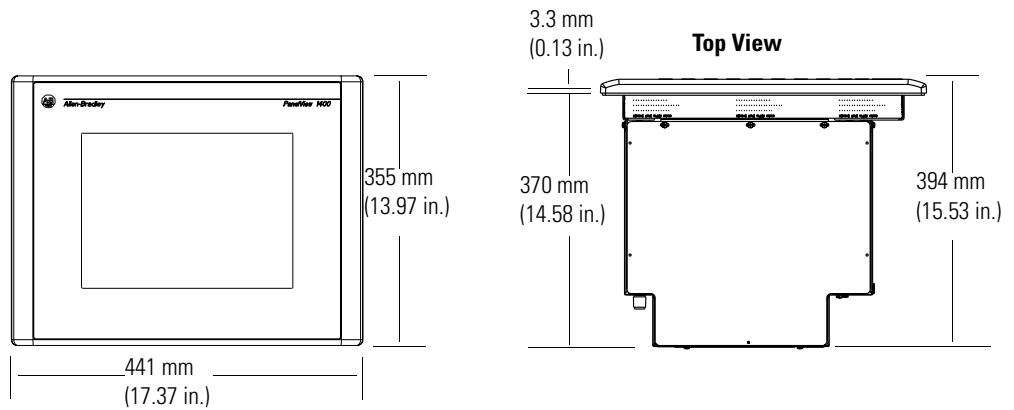

PV1400 Keypad Terminal Mounting Dimensions

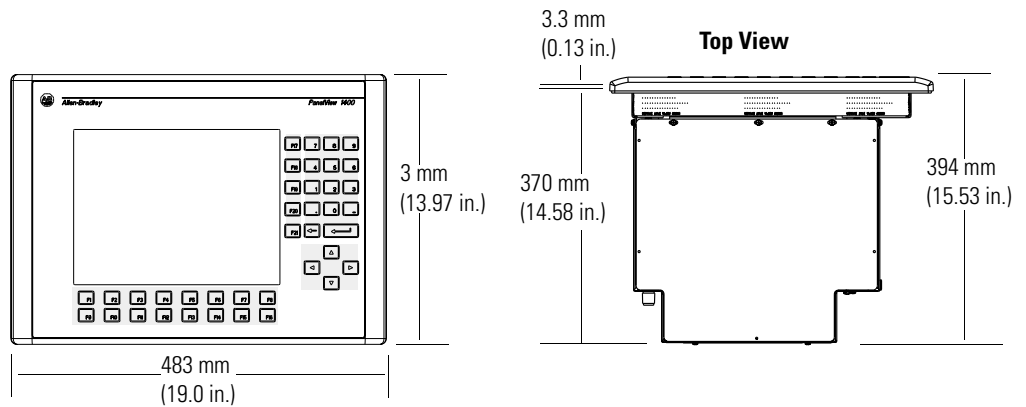

Clearances

Allow adequate space for mounting, air flow, maintenance, adjusting brightness/contrast, memory card and legend strip installation.

IMPORTANT

If using a memory card, allow a back clearance to load the card.

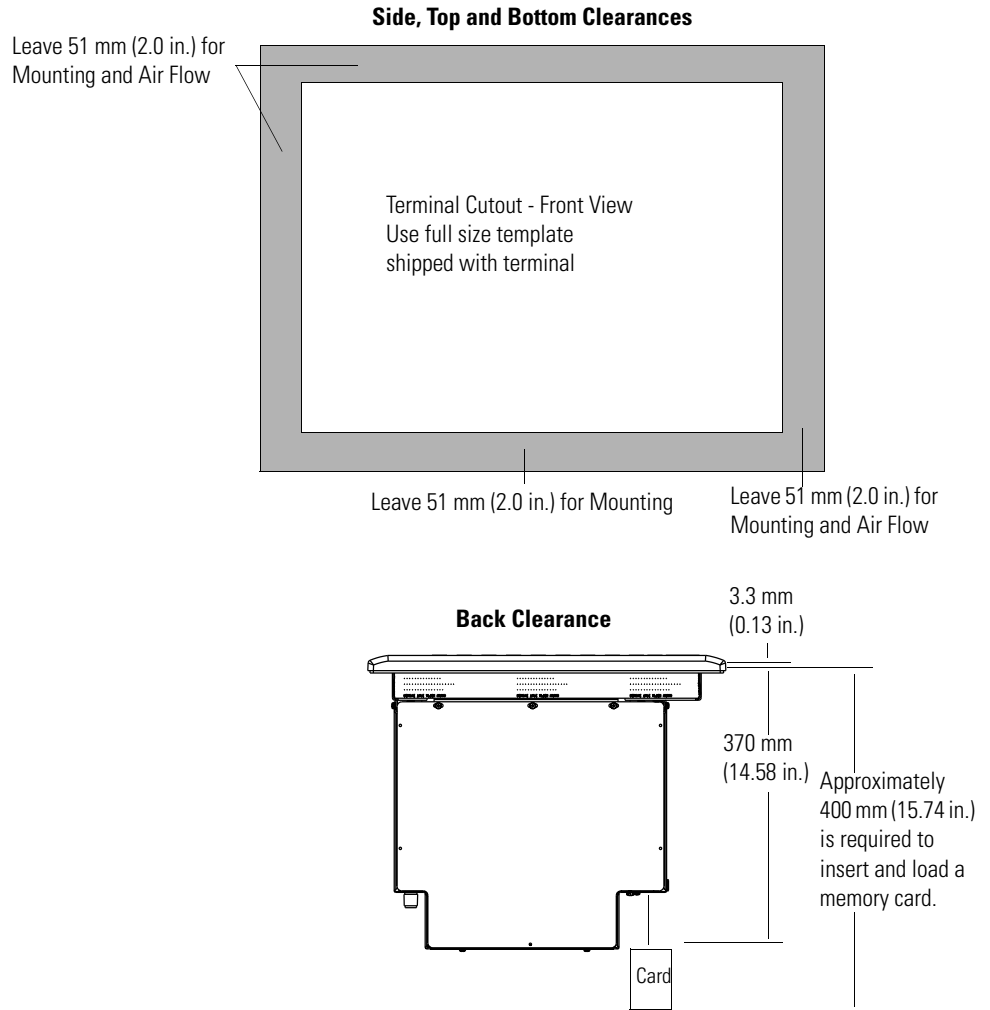

Cutout Dimensions

Use the full size template provided with the terminal to mark cutout dimensions. The illustration below shows reduced size cutouts with dimensions.

PV1400 Keypad Terminals

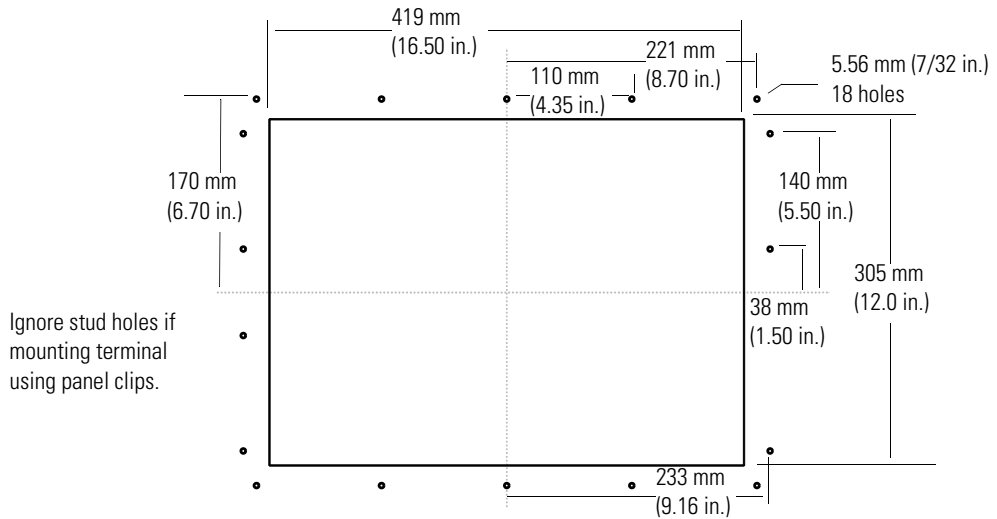

PV1400 Touch Screen Terminals

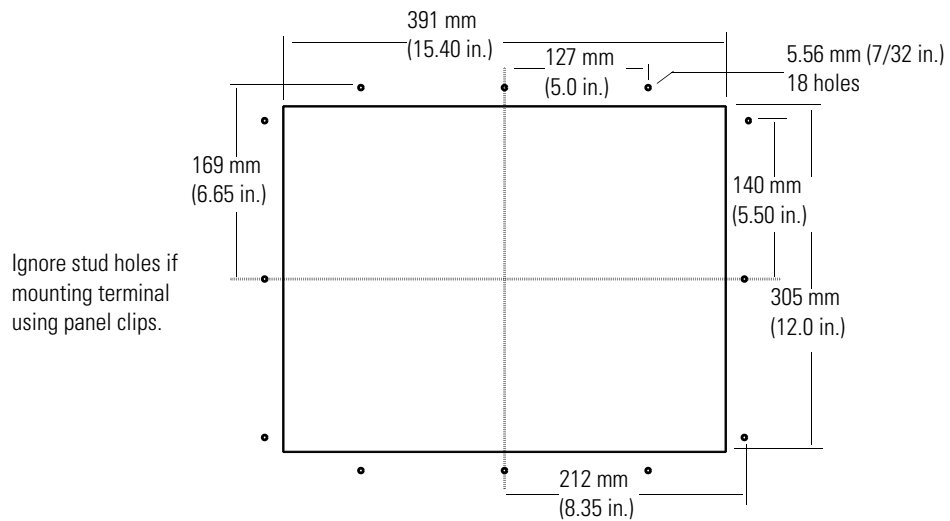

Install the PV1400 Terminal in a Panel

This section gives procedures for mounting a PV1400 terminal by using:

- mounting clips (10 shipped with terminal, 10 required)
- mounting studs (ordered separately, Catalog No. 2711-NP3)

ATTENTION



- Disconnect all electrical power from the panel before making the cutout.
- Make sure the area around the panel cutout is clear.
- Do not allow metal cuttings to enter any components that may already be installed in the panel.
- Failure to follow this warning may result in personal injury or damage to the panel components.

Follow these steps to install the PV1400 terminal in a panel using clips.

1. Cut an opening in the panel by using the panel cutout template provided with the terminal and remove any sharp edges or burrs.

Do not drill the mounting stud holes if you are using clips.

2. Make sure the sealing gasket is properly positioned on the terminal, particularly around the mounting studs as shown.

This gasket forms a compression type seal. Do not use sealing compounds.

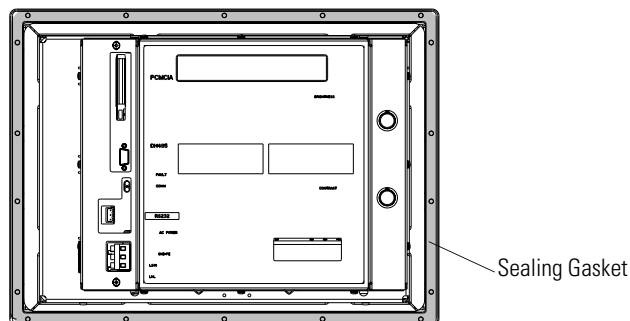

Although the keypad legend strip can be installed any time, we recommend that you install them after the terminal is installed.

3. Place the PV1400 terminal in the panel cutout.

The terminal will snap into the panel as the temporary retaining tabs lock against the panel.

TIP

The PV1400 terminal has two metal tabs (on bottom edge) that temporarily lock the terminal against the panel. These tabs only facilitate installation of the mounting hardware. The tabs are not designed to provide permanent mounting.

4. Install the 10 mounting clips (three on top, three on bottom, two on each side).

The ends of the clips slide into slots on the terminal.

5. Tighten the clip mounting screws hand tight.

Install 10 Mounting Clips

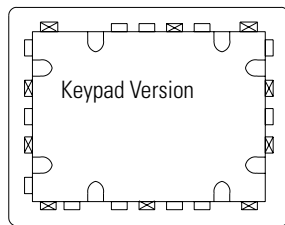

☒ = Recommended Placement of Mounting Clips

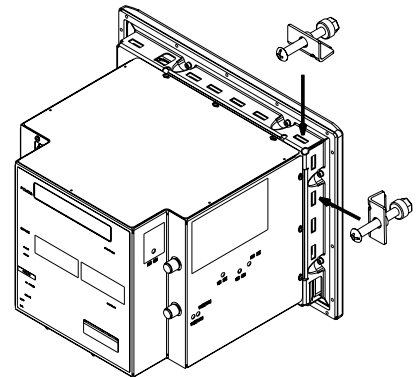
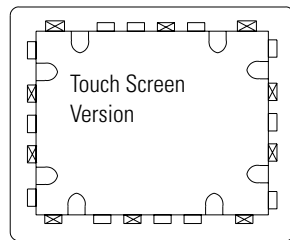

6. Alternately tighten the mounting clip screws until the terminal is held firmly against the panel.
7. Tighten mounting screws to a torque of 1.13 Nm (10 lb-in.).

Do not over-tighten.

ATTENTION



Mounting nuts must be tightened to a torque of 1.13 Nm (10 lb-in.) to provide a proper seal and to prevent potential damage to the terminal. Allen-Bradley assumes no responsibility for water or chemical damage to the terminal or other equipment within the enclosure because of improper installation.

Mount Terminal with Mounting Studs

Follow these steps to install the PV1400 terminal in a panel by using mounting studs.

1. Cut an opening in the panel by using the panel cutout template shipped with the terminal.
2. Carefully drill 5.56 mm (7/32 in.) holes for studs as indicated.
3. Install the mounting studs (Cat. No. 2711-NP3) using a 7/32-inch socket on the end of the stud.
4. Turn stud clockwise and tighten to approximately 1.13 Nm (10 in.-lb).

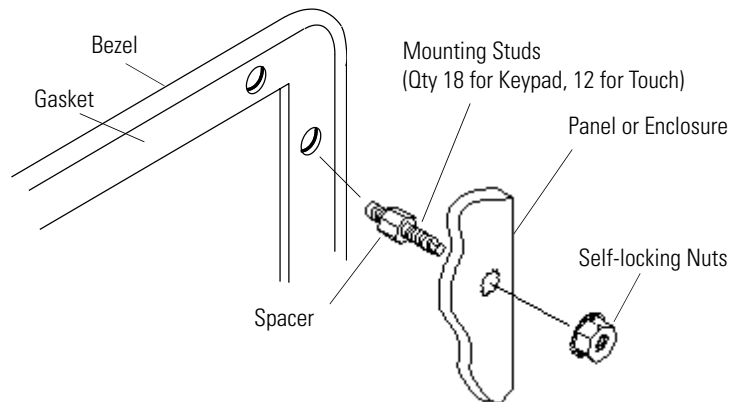

5. Make sure the sealing gasket is properly positioned on the terminal.

This gasket forms a compression type seal (NEMA Type 4). Do not use sealing compounds.

ATTENTION



Be careful not to damage the sealing gasket when installing or removing studs. A damaged seal may result in damage to the PanelView terminal and other panel components due to a leaking seal.

6. Place the PV1400 terminal in the panel cutout aligning the studs with the mounting holes.

7. Install the self-locking nuts hand tight.

ATTENTION



Tighten mounting nuts to a torque of 1.13 Nm (10 lb-in.) to provide a proper seal and prevent potential damage to the terminal. Allen-Bradley assumes no responsibility for water or chemical damage to the terminal or other equipment within the enclosure because of improper installation. A properly installed terminal has a small gap between the bezel and enclosure.

8. Alternately tighten the self-locking nuts (use 3/8 in. socket) until the PV1400 terminal is held firmly against the panel.

The recommended tightening sequence is shown below.

The studs have an integral spacer that prevents the gasket from being over-compressed. The amount of torque required increases significantly as the gasket reaches the proper compression. Tighten nuts to a torque of 1.13 Nm (10 lb-in.).

18	9	1	5	13
16				15
4	Recommended Torque Sequence Keypad Terminals			3
7				8
12				11
17	10	2	6	14

	9	1	5	
7				8
4	Recommended Torque Sequence Touch Terminals			3
12				11
	10	2	6	

Note the sequence starts at center studs and continues to the corner studs.

Terminal Connections

Chapter Objectives

This chapter describes network and device connections for PanelView terminals.

- Wiring and safety guidelines
- Cable charts
- Remote I/O connections
- DH+ connections
- DH-485 connections
- RS-232 (DH-485) connections
- RS-232 (DF1) connections
- ControlNet connections
- DeviceNet connections
- EtherNet/IP connections
- PanelView 300 Micro connections
- Computer or printer connection to RS-232 serial port

Wiring and Safety Guidelines

Use publication NFPA 70E, Electrical Safety Requirements for Employee Workplaces when wiring the PanelView terminals. In addition to the NFPA general guidelines:

- route communication cables to terminal by a separate path from incoming power.

IMPORTANT

Do not run signal wiring and power wiring in the same conduit.

- where power and communication lines must cross, they should cross at right angles. Communication lines can be installed in the same conduit as low level dc I/O lines (less than 10 volts).
- grounding minimizes noise from Electromagnetic Interference (EMI) and is a safety measure in electrical installations.
- use the National Electric Code published by the National Fire Protection Association as a source for grounding.

Cable Charts

Refer to the following charts for a summary of PanelView terminal connections to controllers and network interface modules.

Runtime Communication Cables - to Processors

Protocol	PanelView Standard Comm Port	Cables: PanelView to Processor				
		SLC-500, 5/01, 5/02 CH1 RJ45 (DH-485)	SLC-5/03, 5/04, 5/05 CH0 (9-pin RS-232) (DF1 or DH-485)	SLC 5/03 CH1 (RJ45) (DH-485)	SLC 5/04 CH1 (DH+)	SLC 5/05 CH1 (ENET)
DF1 xxx16 xxx17 xxx18	RS-232 (DF1) Comm Port (8-pin Mini Din) PanelView 300 Micro 2711-xxx18	N/A	1761-CBL-AP00 (0.5 m/1.5 ft) 1761-CBL-PM02 (2 m/6.5 ft) 2711-CBL-PM05 (5 m/16 ft) 2711-CBL-PM10 (10 m/32 ft)	N/A	N/A	N/A
	RS-232 (DF1) Communication Port (9-pin) PanelView 300 - 1400 2711-xxx16, 2711-xxx17	N/A	2711-NC13 (5 m/16 ft) 2711-NC14 (10 m/32 ft) 2706-NC13 (3 m/10 ft)	N/A	N/A	N/A
DH-485 xxx2 xxx3 xxx5 xxx9 xxx19	RS-232 (DH-485) Comm Port (8-pin Mini Din) PanelView 300 Micro 2711-xxx19	use AIC+ Module (1761-NET-AIC) Connect to Port 1 or 2	1761-CBL-AP00 (0.5 m/1.5 ft) 1761-CBL-PM02 (2 m/6.5 ft) 2711-CBL-PM05 (5 m/16 ft) 2711-CBL-PM10 (10 m/32 ft)	use AIC+ Module (1761-NET-AIC) Connect to Port 1 or 2	N/A	N/A
	RS-232 (DH-485) Communication Port (9-pin) PanelView 300 - 1400 2711-xxx5, 2711-xxx9	use AIC+ Module (1761-NET-AIC) Connect to Port 1 or 2	2711-NC13 (5 m/16 ft) 2711-NC14 (10 m/32 ft) 2706-NC13 (3 m/10 ft)	use AIC+ Module (1761-NET-AIC) Connect to Port 1 or 2	N/A	N/A
	DH-485 Communication Port (RJ45) PanelView 300 - 1400 2711-xxx2, 2711-xxx3	1747-C10 (2 m/6 ft) 1747-C11 (1 ft/0.3 m) 1747-C20 (6 m/20 ft)	use AIC+ Module (1761-NET-AIC) Connect to Port 3	1747-C10 (2 m/6 ft) 1747-C11 (1 ft/0.3 m) 1747-C20 (6 m/20 ft)	N/A	N/A

Protocol	PanelView Standard Comm Port	Cables: PanelView to Processor				
		SLC-500, 5/01, 5/02 CH1 RJ45 (DH-485)	SLC-5/03, 5/04, 5/05 CH0 (9-pin RS-232) (DF1 or DH-485)	SLC 5/03 CH1 (RJ45) (DH-485)	SLC 5/04 CH1 (DH+)	SLC 5/05 CH1 (ENET)
DeviceNet xxx10	DeviceNet Communication Port PanelView 300 - 1400 2711-xxx10	to SLC 5/02 with 1747-SDN and DeviceNet cable	use 1747-SDN Module with DeviceNet cable			
ControlNet xxx15	ControlNet Communication Port PanelView 550T - 1400 2711-xxx15	N/A	not applicable - PanelView does not support SLC ControlNet configurations			
EtherNet/IP xxx20	Ethernet Comm Port PanelView 550T - 1400 2711-xxx20	N/A	N/A	N/A	N/A	Ethernet cable

Protocol	PanelView Standard Comm Port	Cables: PanelView to Processor		
		PLC-5, PLC-5C, PLC-5E CH0 (25-pin RS-232) (DF1)	ControlLogix CH0 (9-pin RS-232) (DF1)	MicroLogix 1000, 1200, 1500LSP CH0 (8-pin Mini DIN) (DF1 or DH-485)
DF1 xxx16 xxx17 xxx18	RS-232 (DF1) Comm Port (8-pin Mini Din) PanelView 300 Micro 2711-xxx18	1761-CBL-AP00 (1.5 ft/0.5 m) 1761-CBL-PM02 (6.5 ft/2 m) 2711-CBL-PM05 (16 ft/5 m) 2711-CBL-PM10 (32 ft/10 m) (9-to-25 pin adapter required)	1761-CBL-AP00 (1.5 ft/0.5 m) 1761-CBL-PM02 (6.5 ft/2 m) 2711-CBL-PM05 (16 ft/5 m) 2711-CBL-PM10 (32 ft/10 m)	1761-CBL-AM00 (1.5 ft/0.5 m) 1761-CBL-HM02 (6.5 ft/2 m) 2711-CBL-HM05 (16 ft/5 m) 2711-CBL-HM10 (32 ft/10 m) ⁽¹⁾
	RS-232 (DF1) Communication Port (9-pin) PanelView 300 - 1400 2711-xxx16, 2711-xxx17	2711-NC13 (16 ft/5 m) 2711-NC14 (32 ft/10 m) 2706-NC13 (10 ft/3 m) (9-to-25 pin adapter required)	2711-NC13 (16 ft/5 m) 2711-NC14 (32 ft/10 m) 2706-NC13 (10 ft/3 m)	2711-NC21 (16 ft/5 m) 2711-NC22 (49 ft/15 m) (null modem not required) ⁽¹⁾
DH-485 xxx2 xxx3 xxx5 xxx9 xxx19	RS-232 (DH-485) Comm Port (8-pin Mini Din) PanelView 300 Micro 2711-xxx19	N/A	N/A	1761-CBL-AM00 (1.5 ft/0.5 m) 1761-CBL-HM02 (6.5 ft/2 m) 2711-CBL-HM05 (16 ft/5 m) 2711-CBL-HM10 (32 ft/10 m) ⁽¹⁾
	RS-232 (DH-485) Communication Port (9-pin) PanelView 300 - 1400 2711-xxx5, 2711-xxx9	N/A	N/A	2711-NC21 (16 ft/5 m) 2711-NC22 (49 ft/15 m) (null modem not required) ⁽¹⁾
	DH-485 Communication Port (RJ45) PanelView 300 - 1400 2711-xxx2, 2711-xxx3	N/A	N/A	use AIC+ Module (1761-NET-AIC) Connect to Port 3
DeviceNet xxx10	DeviceNet Communication Port PanelView 300 - 1400 2711-xxx10	use 1771-SDN Module with DeviceNet cable	use 1756-DNB Module with DeviceNet cable	use 1761-NET-DNI Module with DeviceNet cable
ControlNet xxx15	ControlNet Communication Port PanelView 550T - 1400 2711-xxx15	to PLC-5C with ControlNet cable	use 1756-CNB Module with ControlNet cable	N/A

Protocol	PanelView Standard Comm Port	Cables: PanelView to Processor		
		PLC-5, PLC-5C, PLC-5E CH0 (25-pin RS-232) (DF1)	ControlLogix CH0 (9-pin RS-232) (DF1)	MicroLogix 1000, 1200, 1500LSP CH0 (8-pin Mini DIN) (DF1 or DH-485)
EtherNet/IP xxx20	Ethernet Communication Port PanelView 550T - 1400 2711-xxx20	to PLC-5E with Ethernet cable	Use 1756-ENET Module with Ethernet cable	Use 1761-NET-ENI Module with Ethernet cable
Remote I/O xxx1	Remote I/O Communication Port PanelView 550T - 1400 2711-xxx1	shielded twinaxial cable (1770-CD)	use 1756-DHRIO Module with shielded twinaxial cable (1770-CD)	N/A
DH+ xxx8	DH+ Communication Port PanelView 550T - 1400 2711-xxx8	shielded twinaxial cable (1770-CD)	use 1756-DHRIO Module with shielded twinaxial cable (1770-CD)	N/A

⁽¹⁾ AIC + Module recommended for isolation purposes when PanelView and controller are not on same power supply

Protocol	PanelView Standard Comm Port	Cables: PanelView to Processor		
		MicroLogix 1500LRP CH1 (9-pin RS-232) (DF1 or DH-485)	CompactLogix CH0 (9-pin RS-232) (DF1 or DH-485)	FlexLogix CH0 (9-pin RS-232) (DF1)
DF1 xxx16 xxx17 xxx18	RS-232 (DF1) Comm Port (8-pin Mini Din) PanelView 300 Micro 2711-xxx18	1761-CBL-AP00 (1.5 ft/0.5 m) 1761-CBL-PM02 (6.5 ft/2 m) 2711-CBL-PM05 (16 ft/5 m) 2711-CBL-PM10 (32 ft/10 m)	1761-CBL-AP00 (1.5 ft/0.5 m) 1761-CBL-PM02 (6.5 ft/2 m) 2711-CBL-PM05 (16 ft/5 m) 2711-CBL-PM10 (32 ft/10 m)	1761-CBL-AP00 (1.5 ft/0.5 m) 1761-CBL-PM02 (6.5 ft/2 m) 2711-CBL-PM05 (16 ft/5 m) 2711-CBL-PM10 (32 ft/10 m)
	RS-232 (DF1) Communication Port (9-pin) PanelView 300 - 1400 2711-xxx16, 2711-xxx17	2711-NC13 (16 ft/5 m) 2711-NC14 (32 ft/10 m) 2706-NC13 (10 ft/3 m)	2711-NC13 (16 ft/5 m) 2711-NC14 (32 ft/10 m) 2706-NC13 (10 ft/3 m)	2711-NC13 (16 ft/5 m) 2711-NC14 (32 ft/10 m) 2706-NC13 (10 ft/3 m)
DH-485 xxx2 xxx3 xxx5 xxx9 xxx19	RS-232 (DH-485) Comm Port (8-pin Mini Din) PanelView 300 Micro 2711-xxx19	1761-CBL-AP00 (1.5 ft/0.5 m) 1761-CBL-PM02 (6.5 ft/2 m) 2711-CBL-PM05 (16 ft/5 m) 2711-CBL-PM10 (32 ft/10 m)	1761-CBL-AP00 (1.5 ft/0.5 m) 1761-CBL-PM02 (6.5 ft/2 m) 2711-CBL-PM05 (16 ft/5 m) 2711-CBL-PM10 (32 ft/10 m)	N/A
	RS-232 (DH-485) Communication Port (9-pin) PanelView 300 - 1400 2711-xxx6, 2711-xxx9	2711-NC13 (16 ft/5 m) 2711-NC14 (32 ft/10 m) 2706-NC13 (10 ft/3 m)	2711-NC13 (16 ft/5 m) 2711-NC14 (32 ft/10 m) 2706-NC13 (10 ft/3 m)	N/A
	DH-485 Communication Port (RJ45) PanelView 300 - 1400 2711-xxx2, 2711-xxx3	use AIC+ Module (1761-NET-AIC) Connect to Port 3	use AIC+ Module (1761-NET-AIC) Connect to Port 3	N/A
DeviceNet xxx10	DeviceNet Communication Port PanelView 300 - 1400 2711-xxx10	use 1761-NET-DNI Module with DeviceNet cable		N/A
ControlNet xxx15	ControlNet Communication Port PanelView 550T - 1400 2711-xxx15	N/A	N/A	use 1788-CNC module with ControlNet cable
EtherNet/IP xxx20	Ethernet Communication Port PanelView 550T - 1400 2711-xxx20	use 1761-NET-ENI Module with Ethernet cable	use 1761-NET-ENI Module with Ethernet cable	use 1761-NET-ENI Module with Ethernet cable
Remote I/O xxx1	Remote I/O Communication Port PanelView 550T - 1400 2711-xxx1	N/A	N/A	N/A
DH+ xxx8	DH+ Communication Port PanelView 550T - 1400 2711-xxx8	N/A	N/A	N/A

Runtime Communication Cables - to Network Interface Module

Protocol	PanelView Standard Comm Port	Cables: PanelView to Interface Module				1761-NET-DNI or 1761-NET-ENI
		1747-AIC	1761-NET-AIC			
DF1 xxx16 xxx17 xxx18	RS-232 (DF1) Comm Port (8-pin Mini Din) PanelView 300 Micro 2711-xxx18	N/A	1761-CBL-AP00 (1.5 ft/0.5 m) 1761-CBL-PM02 (6.5 ft/2 m) 2711-CBL-PM05 (16 ft/5 m) 2711-CBL-PM10 (32 ft/10 m)	1761-CBL-AM00(1.5 ft/0.5 m) 1761-CBL-HM02(6.5 ft/2 m) 2711-CBL-HM05 (16 ft/5 m) 2711-CBL-HM10 (32 ft/10 m)	N/A	1761-CBL-AM00 (1.5 ft/0.5 m) 1761-CBL-HM02 (6.5 ft/2 m) 2711-CBL-HM05 (16 ft/5 m) 2711-CBL-HM10 (32 ft/10 m)
	RS-232 (DF1) Communication Port (9-pin) PanelView 300 - 1400 2711-xxx16, 2711-xxx17	N/A	2711-NC13 (16 ft/5 m) 2711-NC14 (32 ft/10 m) 2706-NC13 (10 ft/3 m)	2711-NC21 (16 ft/5 m) 2711-NC22 (49 ft/15 m) (null modem not required)		1761-CBL-AP00 (1.5 ft/0.5 m) 1761-CBL-PM02 (6.5 ft/2 m) 2711-CBL-PM05 (16 ft/5 m) 2711-CBL-PM10 (32 ft/10 m)
DH-485 xxx2 xxx3 xxx5 xxx9 xxx19	RS-232 (DH-485) Comm Port (8-pin Mini Din) PanelView 300 Micro 2711-xxx19	N/A	1761-CBL-AP00 (1.5 ft/0.5 m) 1761-CBL-PM02 (6.5 ft/2 m) 2711-CBL-PM05 (16 ft/5 m) 2711-CBL-PM10 (32 ft/10 m)	1761-CBL-AM00(1.5 ft/0.5 m) 1761-CBL-HM02(6.5 ft/2 m) 2711-CBL-HM05 (16 ft/5 m) 2711-CBL-HM10 (32 ft/10 m)	N/A	N/A
	RS-232 (DH-485) Communication Port (9-pin) PanelView 300 - 1400 2711-xxx5, 2711-xxx9	N/A	2711-NC13 (16 ft/5 m) 2711-NC14 (32 ft/10 m) 2706-NC13 (10 ft/3 m)	2711-NC21 (16 ft/5 m) 2711-NC22 (49 ft/15 m) (null modem not required)	N/A	N/A
	DH-485 Communication Port (RJ45) PanelView 300 - 1400 2711-xxx2, 2711-xxx3	1747-C10 (6 ft/2 m) 1747-C11 (1 ft/0.3 m) 1747-C20 (20 ft/6 m)	N/A	N/A	1761-CBL-A S03 (10 ft / 3 m) 1761-CBL-A S09 (30 ft / 9 m)	N/A

Application File Upload/Download (Direct) Cables

PanelView Standard Type	Cable to Personal Computer
PanelView 300 Micro 2711-M3A18L1, -M3A19L1	1761-CBL-PM02 (6.5 ft/2 m) 2711-CBL-PM05 (16 ft/5 m) 2711-CBL-PM10 (32 ft/10 m)
DH-485 Comm Port only or DH-485 Comm Port & RS-232 Printer Port PanelView 300, 550/550T, 600/600T 2711-KxA2, -KxC2, -BxA2, -BxA3, -TxA2, -TxC2, 2711-KxA3, -KxC3, -KxG3, -BxA3, -BxC3, -TxA3, -TxC3, -TxG3	1747-PIC
RS-232 (DH-485) Comm Port only or RS-232 (DH-485) Comm Port & RS-232 Printer Port PanelView 300, 550/550T, 600/600T 2711-KxA5, -KxC5, -BxA5, -BxC5, -TxA5, -TxC5, 2711-KxA9, -KxC9, -KxG9, -BxA9, -BxC9, -TxA9, -TxC9, -TxG9	2711-NC13 (16 ft/5 m) 2711-NC14 (32 ft/10 m) 2706-NC13 (10 ft/3 m)
RS-232 (DF1) Comm Port only PanelView 300 2711-K3A17	
RS-232 (DF1) Comm Port & RS-232 Printer/Download Port PanelView 550T - 1400 2711-KxA16, -KxC16, -KxG16, -BxA16, -BxC16, -TxA16, -TxC16, -TxG16	
DeviceNet Comm Port & RS-232 Printer Port PanelView 300 - 1400 2711-KxA10, -KxC10, -KxG10, -BxA10, -BxC10, -TxA10, -TxC10, -TxG10	
ControlNet Comm Port & RS-232 Printer Port PanelView 550T - 1400 2711-KxA15, -KxC15, -KxG15, -BxA15, -BxC15, -TxA15, -TxC15, -TxG15	
Remote I/O Comm Port & RS-232 Printer Port PanelView 550T - 1400 2711-KxA1, -KxC1, -KxG1, -BxA1, -BxC1, -TxA1, -TxC1, -TxG1	
Ethernet Comm Port and RS-232 Printer Port PanelView 550T - 1400 2711-KxA20, -KxC20, -KxG20, -BxA20, -BxC20, -TxA20, -TxC20, -TxG20	
DH+ Comm Port & RS-232 Printer Port PanelView 550T - 1400 2711-KxA8, -KxC8, -KxG8, -BxA8, -BxC8, -TxA8, -TxC8, -TxG8	
Profibus Comm Port & RS-232 Printer Port PanelView 550T - 1400 2711-KxA12, -KxC12, -KxG12, -BxA12, -BxC12, -TxA12, -TxC12, -TxG12	
Modbus Comm Port & RS-232 Printer Port PanelView 550T - 1400 2711-KxA14, -KxC14, -KxG14, -BxA14, -BxC14, -TxA14, -TxC14, -TxG14	

Remote I/O Terminal Connections

This section describes connections for the remote I/O PanelView terminals including:

- remote I/O port.
- supported controllers.
- making remote I/O connections.
- remote I/O pass-through.

Remote I/O Terminal Ports

The remote I/O versions of the PanelView terminal (catalog numbers ending in 1) have a remote I/O port and an RS-232 port.

Use the remote I/O port to:

- communicate with the remote I/O scanner port on a PLC controller.
- communicate with SLC controllers using a 1747-SN remote I/O scanner module.
- communicate with other remote I/O scanners.
- transfer applications using remote I/O pass-through.

Use the RS-232 Port to:

- transfer PanelView applications between a computer and the terminal.
- connect a printer.

For details on connecting to the RS-232 port, see [page 223](#).

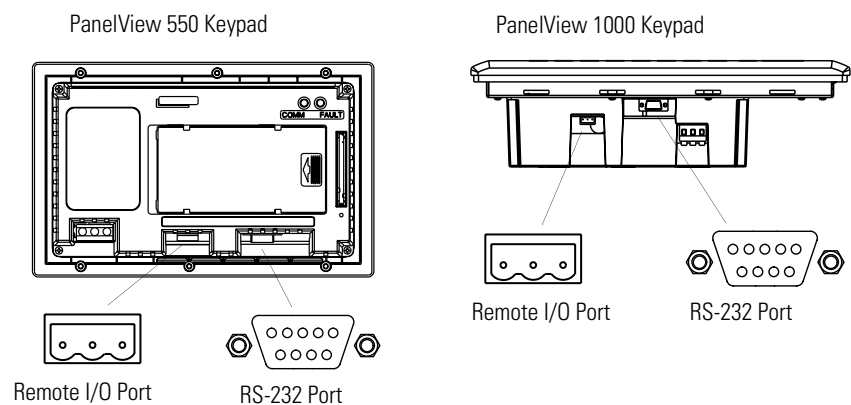

Supported Controllers

The remote I/O terminal connects to any Allen-Bradley 1771 remote I/O link. Applicable host controllers include almost all Allen-Bradley PLCs, computers, VME controllers, and DEC Q-Bus controllers with a remote I/O scanner module. New PLC product releases that support 1771 remote I/O will also work with PanelView.

When connecting a PanelView terminal to a controller refer to the user manual for your controller or scanner module for connection diagrams and any remote I/O limitations. The table below provides a summary of possible connections.

Controller	Scanner	Comments
ControlLogix	1756-DHRIO	Connect PanelView terminals through the 1756-DHRIO module.
PLC-5/11, 5/15 ⁽¹⁾ , 5/20, 5/25, 5/30, 5/60, 5/80, 5/250	PLC Integral 1771-SN	Connect PanelView terminals directly to the remote I/O port (scanner mode). Connect PanelView terminals through the 1771-SN subscanner module.
PLC-5/10, 5/12	1771-SN	Connect PanelView terminals through the 1771-SN subscanner module.
PLC-2	1771-SN or 1772-SD2 ⁽²⁾	Connect PanelView terminals to the PLC-2 family of processors through a 1771-SN I/O subscanner module.
PLC-3 and PLC-3/10	None PLC-3/10 remote I/O Scanner ⁽³⁾	Connect PanelView terminals directly to a PLC-3. Connect PanelView terminals to the PLC-3/10 through the remote I/O scanner.
SLC-5/02, 5/03, 5/04, 5/05	1747-SN	Connect PanelView terminals through the 1747-SN subscanner module. Each module provides an additional remote I/O link for up to 4 racks. Important: Only Series B and later versions of the 1747-SN subscanner support block transfers.
IBM PC	6008-SI	6008-SI I/O scanner is compatible with IBM PC or compatible computers. The scanner provides a computer access to the 1771 remote I/O link.
VME	6008-SV	6008-SV I/O scanner provides access to the 1771 remote I/O link for VME controllers.
DEC Q-BUS	6008-SQ	6008-SQ I/O scanner provides access to the 1771 remote I/O link for DEC Q-BUS controllers.

⁽¹⁾ If using a PLC-5/15 with partial rack addressing and block transfers, you must use Series B, Rev. J or later.

⁽²⁾ If using a 1772-SD2 Remote Scanner/Distribution Panel, use revision 3 or later.

⁽³⁾ If using a 1775-S4A Remote Scanner/Distribution Panel, user Series B or later.

Making Remote I/O Connections

To connect a PanelView terminal to a remote I/O scanner, use cable Catalog No. 1770-CD (equivalent to Belden 9463). The maximum cable length (link distance) is determined by the communication rate.

- 2,800 m (10,000 ft) for 57.6K baud
- 1,400 m (5,000 ft) for 115.2K baud
- 700 m (2,500 ft) for 230.4K baud

See Programmable Controller Wiring and Grounding Guidelines, publication 1770-4.1. The user manual for the I/O scanner module also provides cabling information.

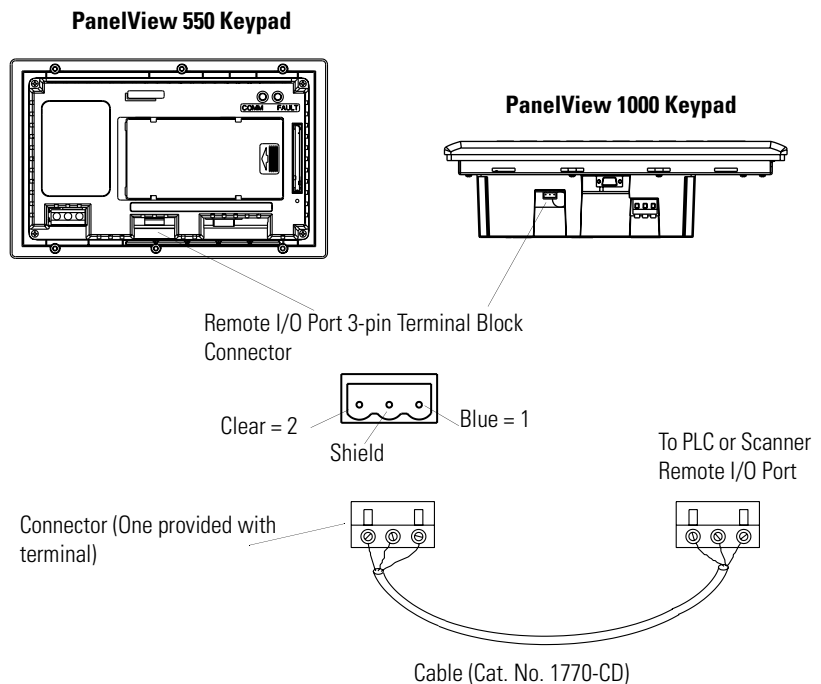

TIP

The polarity of the remote I/O connector on the PanelView terminal is reversed from the PLC Scanner connector. However, the polarity is the same as the scanner card connection to the SLC controller.

TIP

If the terminal is the last device on the link, connect a 1/2 watt terminating resistor across terminals 1 and 2. The value of the resistor depends on the remote I/O communication rate:

- for 57.6 kilobaud and 115.2 kilobaud, use a 150-ohm resistor
- for 230 kilobaud, use an 82-ohm resistor

Remote I/O Pass-through using DH+

Remote I/O terminals allow the transfer of applications from a computer on the Allen-Bradley DH+ link to a PLC-5 or SLC-5/04 controller. The controller passes data to the PanelView terminal over the remote I/O network.

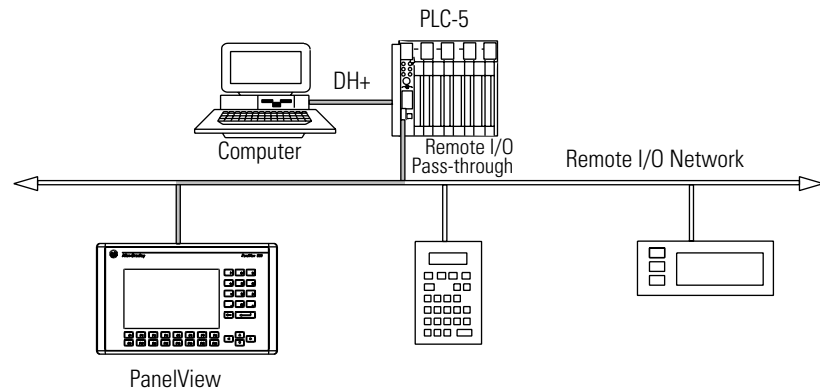

Follow these steps to transfer an application using remote I/O pass-through:

1. A Data Highway Plus Interface Module must be installed in the computer.

Allen-Bradley offers a variety of interface cards for a DH+ connection between a computer and a controller.

2. The appropriate communication driver must be configured on the computer.
3. Connect the computer to the PLC.

See the instruction sheets provided with the communication module or card to select the proper cable.

4. Connect the cable between the computer and the controller.
5. Pass-through must be enabled for the terminal.
6. Check the RIO Configuration screen on the terminal's Configuration Mode menu.

Pass-through is enabled using the out-of-box application provided with the terminal or when defining remote I/O parameters in the PanelBuilder32 software.

7. Refer to the online help in the PanelBuilder32 software for procedures on how to transfer applications by using pass-through.

TIP

If the terminal is the last device on the link, connect a 1/2 watt terminating resistor across terminals 1 and 2. The value of the resistor depends on the DH+ baud rate:

- for 57.6 kilobaud and 115.2 kilobaud, use a 150-ohm resistor
- for 230 kilobaud, use an 82-ohm resistor

DH+ Terminal Connections

This section describes connections for the DH+ PanelView terminals including:

- DH+ ports
- typical DH+ system configuration
- making DH+ connections

DH+ Terminal Ports

The DH+ versions of the PanelView terminals (catalog numbers ending in 8) have a DH+ port and an RS-232 port.

Use the DH+ port to:

- communicate with a PLC-5 controller on the Allen-Bradley DH+ link via the processor's DH+ port.
- communicate with an SLC 5/04 controller (Channel 1 port) on the Allen-Bradley DH+ link via the processor's DH+ port.
- communicate with a ControlLogix controller on the Allen-Bradley DH+ link via the 1756-DHRIO module.
- transfer applications over the DH+ link from a computer with a DH+ connection.

Use the RS-232 port to:

- transfer PanelView applications between a computer and the DH+ terminal using a direct connection.
- connect a printer. For connection details, see the last section in this chapter.

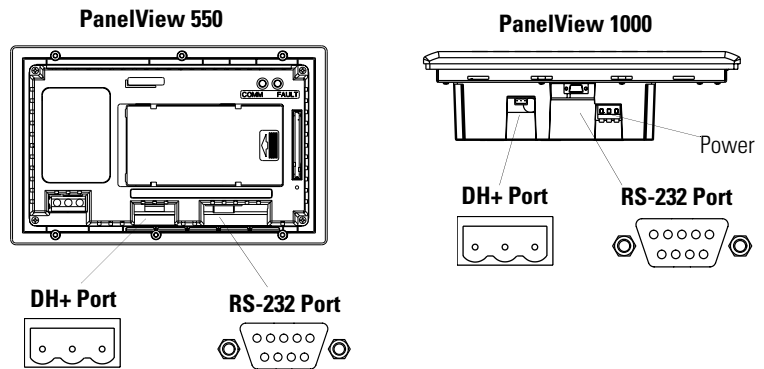

Typical DH+ System Configuration

For more information on the Allen-Bradley DH+ link, refer to the Data Highway/Data Highway Plus/Data Highway II/Data Highway 485 Cable Installation Manual, publication 1770-6.2.2.

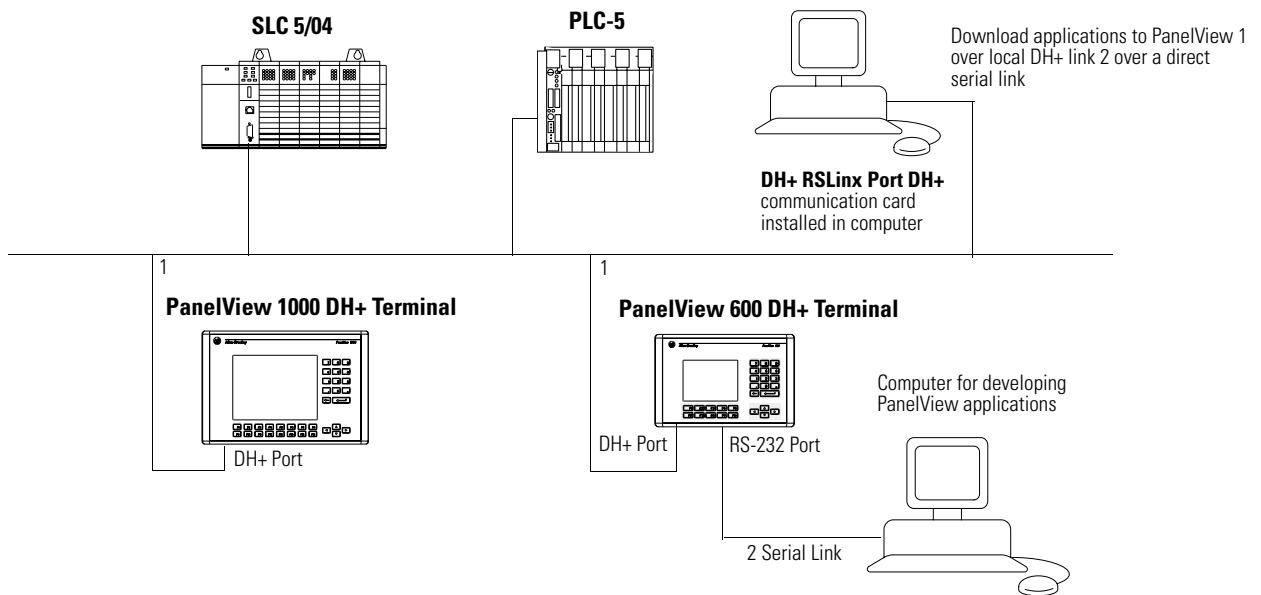

Making DH+ Connections

Use the Belden 9463 twin axial cable (1770-CD) to connect a DH+ PanelView terminal to the DH+ link.

You can connect a DH+ link in 2 ways.

- trunk line/drop line - from the drop line to the connector screw terminals on the DH+ connectors of the processor
- daisy chain - to the connector screw terminals on the DH+ connectors on the processor

Follow these guidelines when installing DH+ communication links.

- do not exceed these cable lengths:
 - trunk line-cable length: 3,048 m (10,000 ft)
 - drop-cable length: 30.4 m (100 ft)
- do not connect more than 64 stations on a single DH+ link

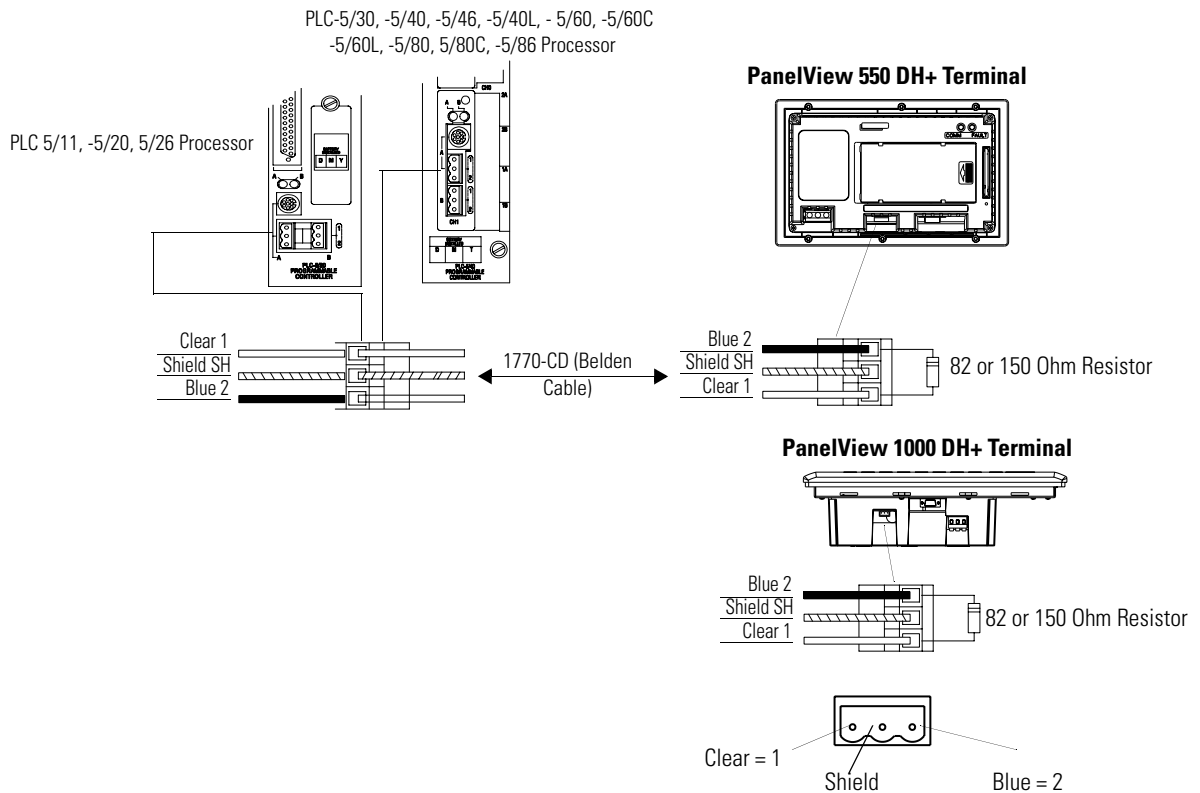

DH-485 Terminal Connections

This section describes connections for the DH-485 PanelView terminals.

- DH-485 terminal ports
- Connecting to a single SLC controller (Point-to-point)
- Connecting to a DH-485 network
- Connecting a computer
- Connecting a Hand-held terminal

TIP

For PanelView 300 Micro terminals, refer to [page 218](#).

DH-485 Terminal Ports (RJ45)

DH-485 PanelView terminals with catalog numbers ending in 2 have two DH-485 ports. Terminals with catalog numbers ending in 3 also have an RS-232 printer port.

Use the DH-485 communication port to:

- communicate with a single or multiple SLC controllers over a DH-485 network.

Use the DH-485 SLC Programming connector to:

- upload/download PanelView applications.
- monitor SLC operation, enter/modify SLC programs, test network devices.

Use the RS-232 Printer port to:

- connect a printer that supports the IBM enhanced character set. For details on connecting to the RS-232 port, see the last section in this chapter.

The DH-485 communication port and programming connector may appear in different locations on specific terminals. Identify the ports by their size and shape or by the port labels.

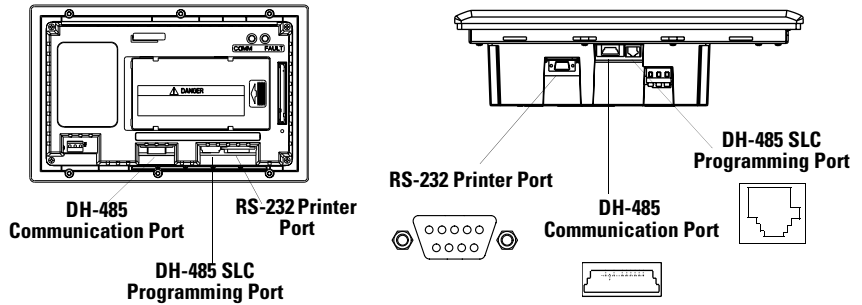

Connecting to a Single SLC Controller (Point-to-point)

To connect a DH-485 terminal to a single SLC controller use one of these cables:

- 0.3 m (1 ft) Cat. No. 1747-C11
- 1.83 m (6 ft) Cat. No. 1747-C10
- 6.1 m (20 ft) Cat. No. 1747-C20

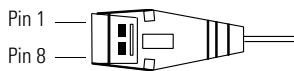
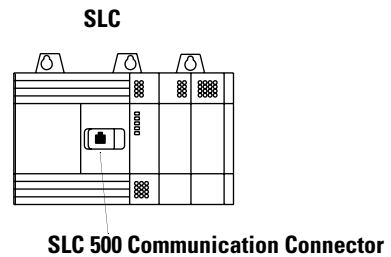
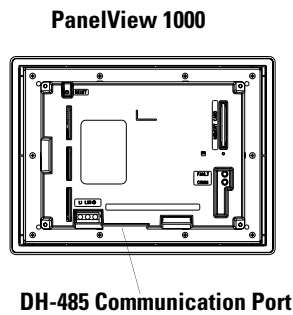

Cable, Catalog No. 1747-C10
 Cable, Catalog No. 1747-C11
 Cable, Catalog No. 1747-C20

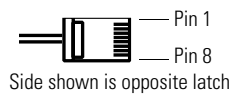

To PanelView Terminal 8-pin Female Plug

Connection Diagram

Pin #	Connect to:	Pin #
1	_____	1
2	_____	2
3	_____	3
4	_____	4
5	_____	5
6	_____	6
7	_____	7
8	_____	8

To SLC Communication Connector 8-pin, Male, Modular Plug

The DH-485 connectors are not electrically isolated. If electrical isolation is required, use Link Couplers (Cat. No. 1747-AIC) as shown on next page.

ATTENTION Electrical isolation using Link Couplers (Cat. No. 1747-AIC) is required where the distance between the PanelView terminal and the SLC is greater than 6.1 m (20 ft).



Connecting to a DH-485 Network

This section shows how to connect a DH-485 terminal to multiple SLC controllers on a DH-485 network through the AIC Link Coupler.

TIP For PanelView 300 Micro terminals, refer to [page 218](#).

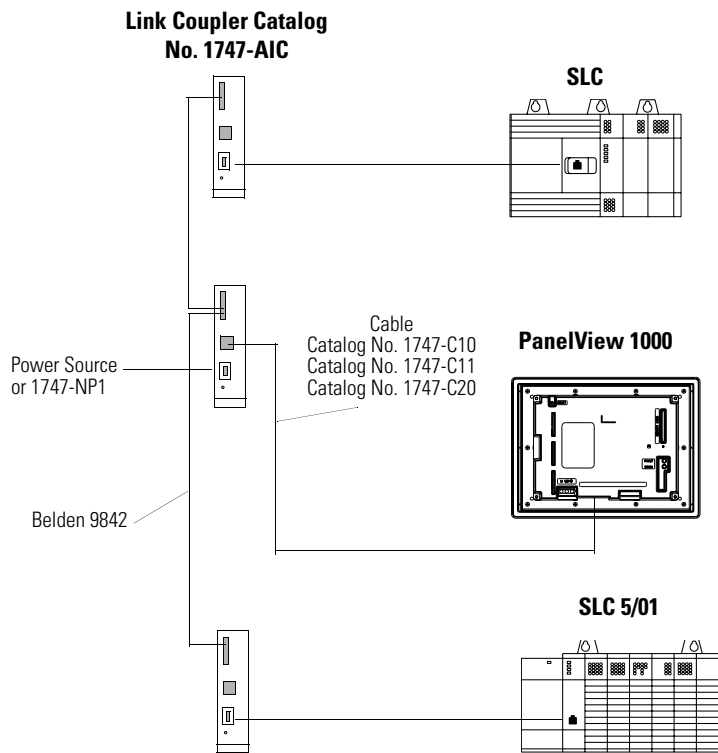

IMPORTANT The DH-485 network cable requires proper shielding, grounding and termination. Refer to Data Highway / Data Highway Plus / Data Highway-485 Cable Installation Manual, publication 1770-6.2.2).

The illustration below shows how to connect a DH-485 terminal to a MicroLogix or SLC controller using the AIC+ Link Coupler (Cat. No. 1761-NET-AIC).

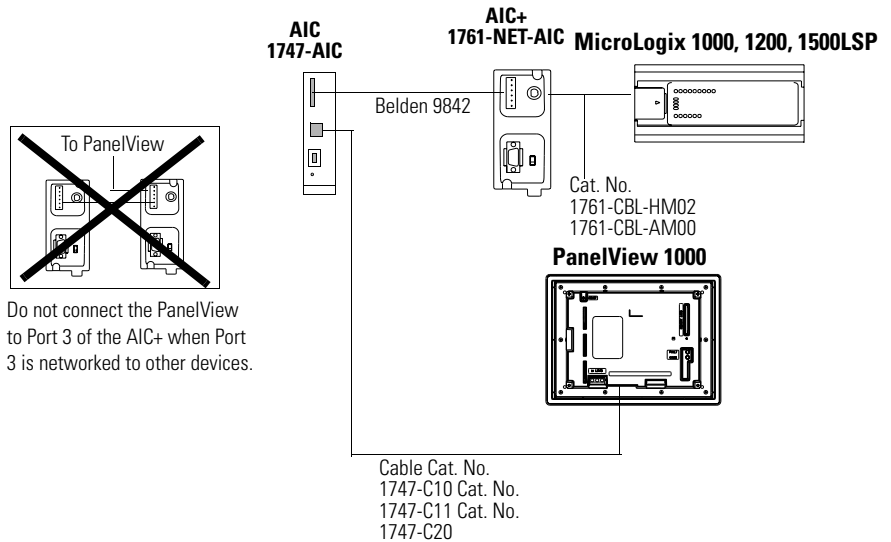
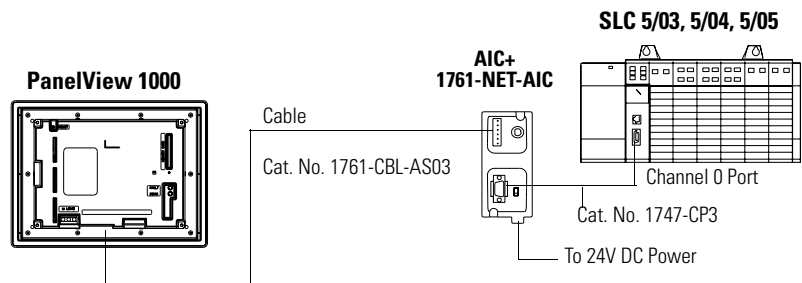
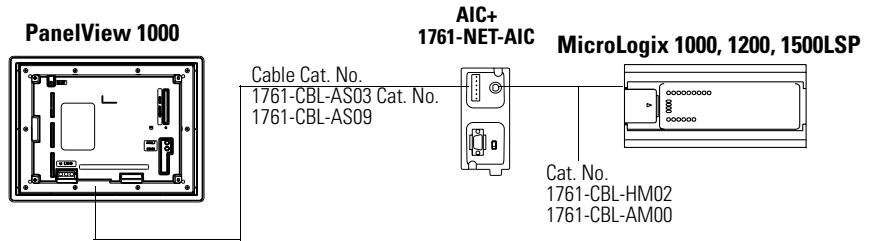

Connecting a Computer

On DH-485 terminals, PanelView applications are transferred:

- through the DH-485 programming connector to the terminal.
- through any node on a DH-485 network.

To connect a computer to the PanelView terminal, you need:

- a cable (same cables used to transfer applications from APS software to SLC)
 - 0.3 m (1 ft) cable, Cat. No. 1747-C11
 - 1.83 m (6 ft) cable, Cat. No. 1747-C10
 - 6.1 m (20 ft) cable, Cat. No. 1747-C20
- Personal Computer Interface Converter (PIC), Cat. No. 1747-PIC. The PIC connects to the computer. The cable connects the PIC to the DH-485 programming connector.

Personal Computer Interface Converter (PIC)

The Personal Computer Interface Converter (PIC) receives power from a controller through DH-485 connections. When connecting a computer directly to a PanelView terminal without a controller connected, you need to use a power supply (Cat. No. 1747-NP1). The power supply connects to the DH-485 communication connector with the same cables used to connect an SLC.

IMPORTANT

The terminal must be connected to an SLC, DH-485 network, or power supply (Cat. No. 1747-NP1). This connection provides power to the PIC.

Connecting Earth Ground to PanelView Terminals

When using the 1747-PIC converter with the PV600, PV900, PV1000 color, and PV1000 grayscale terminals, you must connect the Earth Ground terminal on the back of the terminal to Earth Ground.

Connect the Earth Ground terminal using 14-gauge, stranded wire no longer than 1 meter (40 inches).

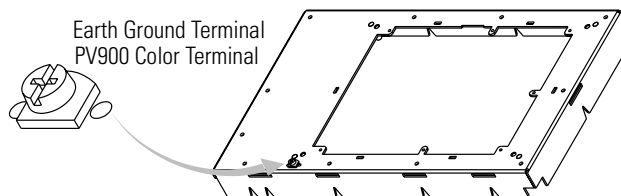

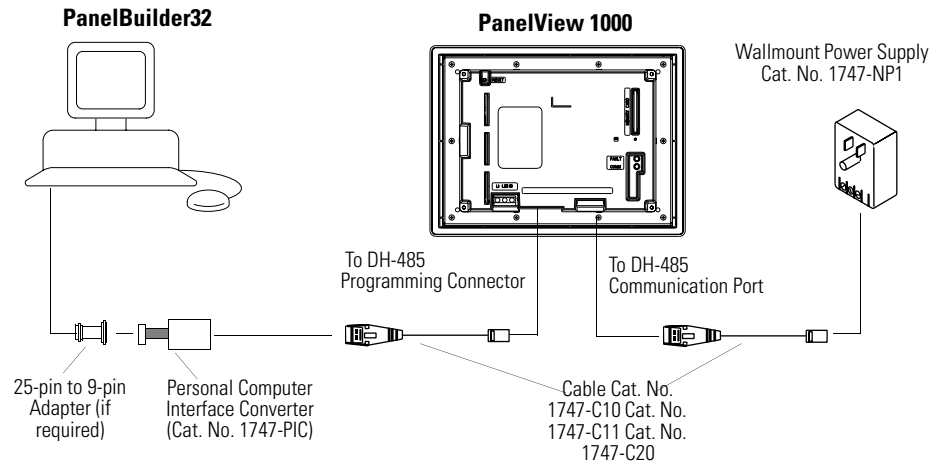
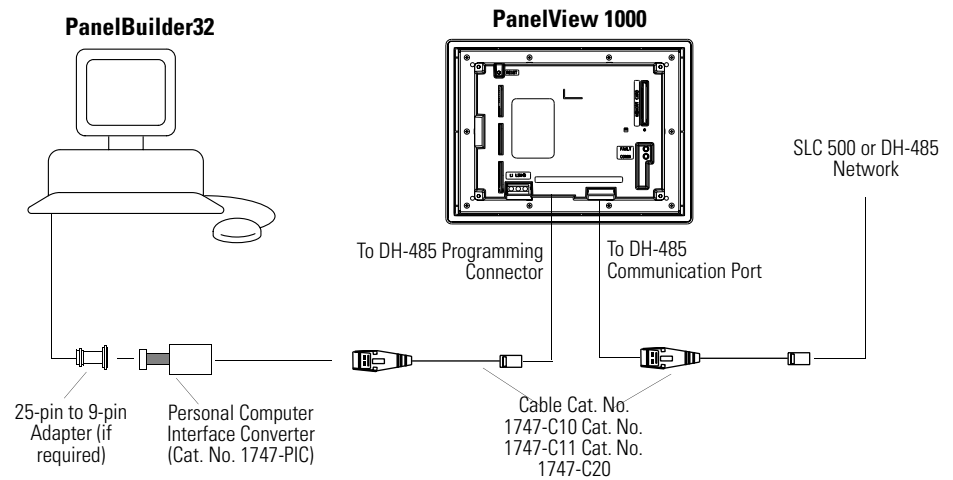
Connecting a Computer to DH-485 Connector Using a Power Supply**Connecting a Computer to DH-485 Connector Using a DH-485 Powered Device****TIP**

The computer can connect to any node on the network. It is not necessary to directly connect the computer to the PanelView terminal.

Connecting a Hand-held Terminal

To connect a Hand-held Terminal (HHT) to the PanelView terminal, use cable Cat. No. 1747-C10. One end of the cable connects to the HHT connector and the other end connects to the DH-485 programming connector on the terminal. All power is supplied to the HHT through the cable.

IMPORTANT

The PanelView terminal must be connected to an SLC, DH-485 network, or power supply. This connection provides power for the HHT.

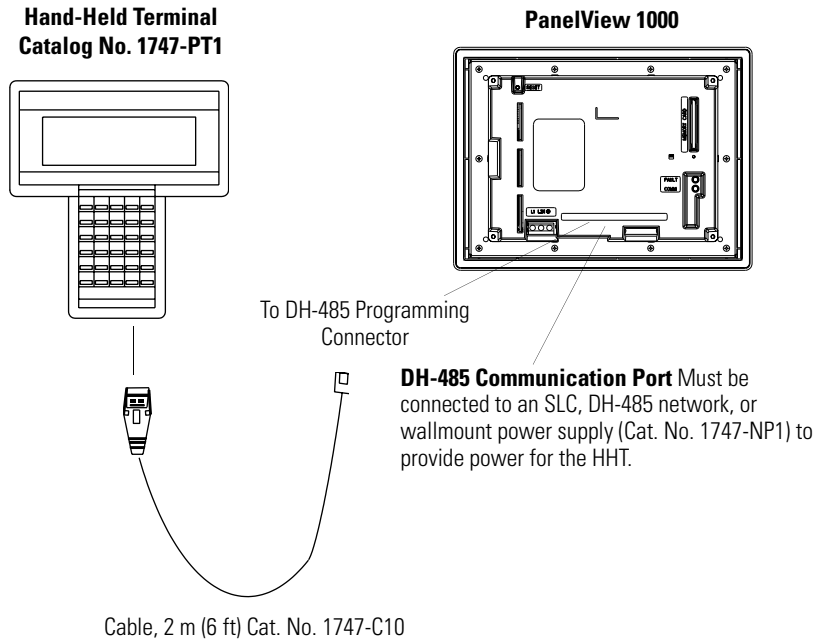

RS-232 (DH-485) Terminal Connections

This section describes connections for the RS-232 (DH-485) PanelView terminals including:

- RS-232 ports
- connecting to a SLC, CompactLogix, or MicroLogix Controller (point-to-point)
- connecting to a MicroLogix Controller through the AIC+ module
- connecting a computer
- connecting to a DH-485 link

Refer to [page 218](#) for PanelView 300 Micro RS-232 connections.

RS-232 Terminal Ports

RS-232 (DH-485) PanelView terminals with catalog numbers ending in 5 have a single RS-232 communication port. Terminals with catalog numbers ending in 9 also have an RS-232 printer port.

Use the RS-232 communication port to:

- communicate with a single SLC 5/03, 5/04 or 5/05 controller (Channel 0 port) or MicroLogix 1000, 1200 or 1500 controller using point-to-point communication
- download/upload PanelView applications

Use the RS-232 printer port to:

- connect a printer that supports the IBM enhanced character set. For connection details, see the last section in this chapter.

The RS-232 communication port and the printer port are reversed on the PanelView 550 touch screen terminals.

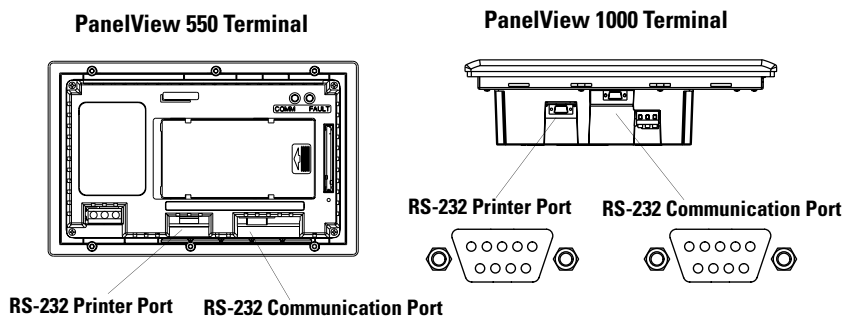

Connecting to an SLC, CompactLogix, MicroLogix Controller (Point-to-point)

This section shows how to connect a CompactLogix, MicroLogix 1500LRP, or SLC controller (SLC 5/03, SLC 5/04, or SLC 5/05) to the RS-232 PanelView terminal for point-to-point (DH-485) communication. On terminals with two ports, use the RS-232 communication port.

For the SLC, CompactLogix or MicroLogix 1500LRP controller, use one of these cables:

- 5 m (16.4 ft) Cat. No. 2711-NC13
- 10 m (32.7 ft) Cat. No. 2711-NC14
- 3 m (10 ft) Cat. No. 2706-NC13

PanelView 1000 Terminal

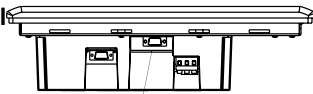

To PanelView Terminal 9-pin, Male, D-Shell Connector

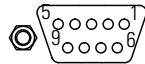

Cable, Cat. No. 2711-NC13
Cable, Cat. No. 2711-NC14
Cable, Cat. No. 2706-NC13

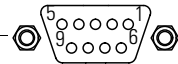

To SLC 5/03, 5/04, 5/05, Compact Logix or MicroLogix 1500LRP Channel 0 Port 9-pin, Male, D-Shell Connector

SLC 5/03, 5/04, 5/05

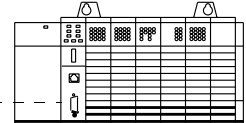

CompactLogix

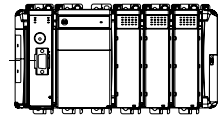

MicroLogix 1500LRP

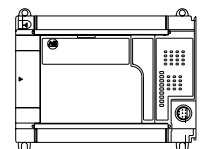

Pin #	Required	Pin #	Required
1		1	
Data Out (TXD) 2	—————	2 Data In (RXD)	
Data In (RXD) 3	—————	3 Data Out (TXD)	
4		4	
Signal Common 5	—————	5 Signal Common	
6		6	
7		7	
8		8	
9		9	

IMPORTANT

You must configure the Channel 0 Port of the SLC 5/03, SLC 5/04, SLC 5/05 controller for DH-485 communication using the Resolute 500 or AI500 software.

For the MicroLogix 1000, MicroLogix 1200, or MicroLogix 1500LSP controller, use one of these cables:

- 5 m (16.4 ft) Cat. No. 2711-NC21
- 15 m (49 ft) Cat. No. 2711-NC22

PanelView 1000 Terminal

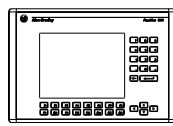

MicroLogix 1000, 1200, 1500LSP

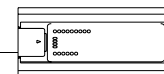

Cable, Cat. No. 2711-NC21
Cable, Cat. No. 2711-NC22
(null modem not required)

Connecting to a MicroLogix Controller through an AIC+ Module

This section shows how to connect the RS-232 (DH-485) version of the PanelView terminal to a MicroLogix controller through an AIC+ Link Coupler.

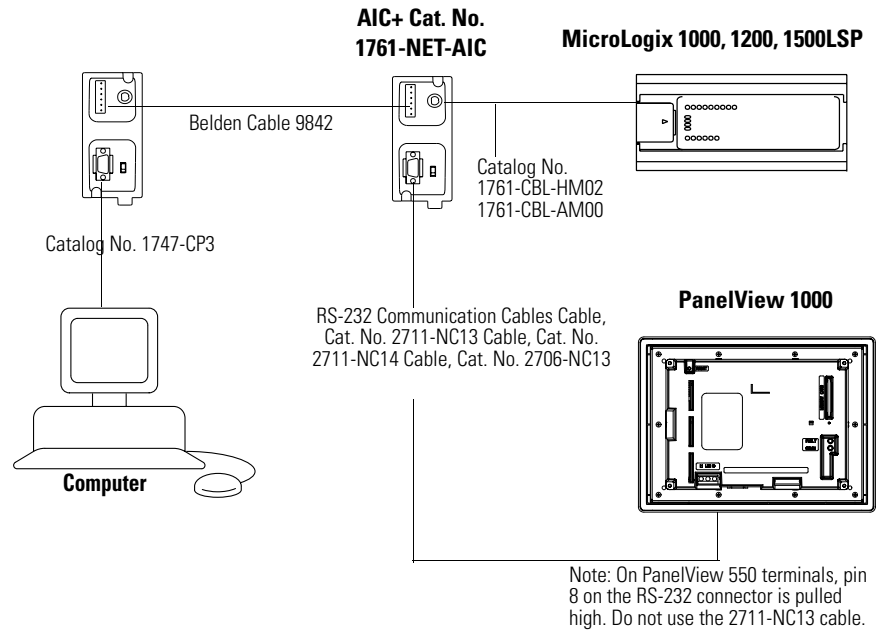

Connecting a Computer

This section shows how to connect a computer to the RS-232 (DH-485) PanelView terminal for transferring applications.

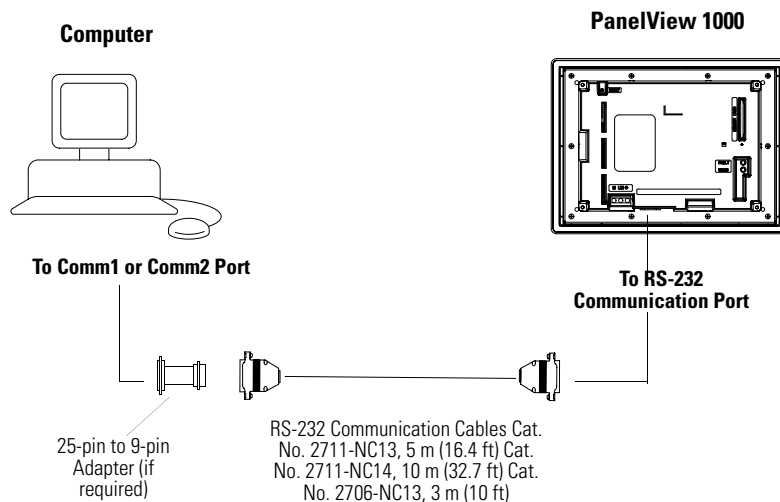

Connecting a DH+ to DH-485 Pass-through Link

This section shows connections for transferring applications between a computer on the Allen-Bradley DH+ link and an RS-232 (DH-485) PanelView terminal, through an SLC 5/04 controller.

The RS-232 (DH-485) communication port on the terminal connects to the CH0 port of the controller using one of the cables listed below.

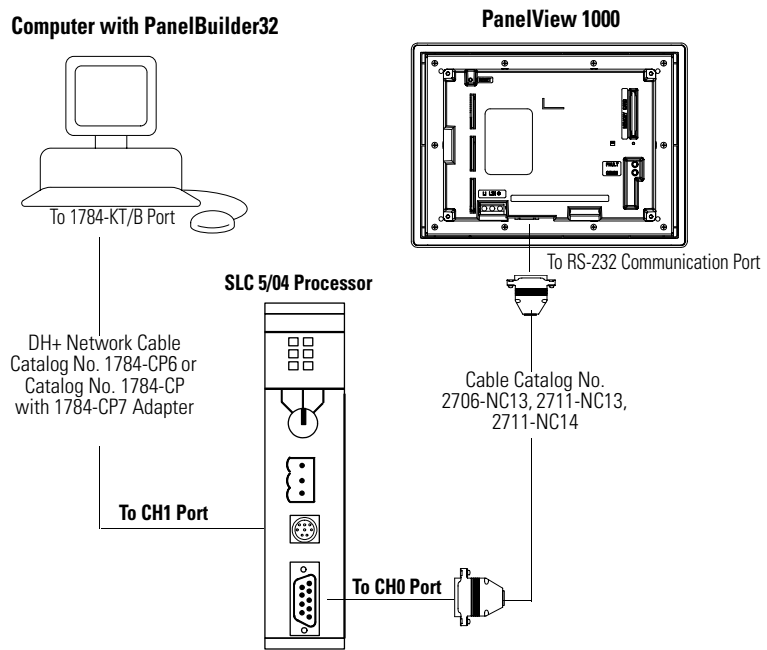

RS-232 (DF1) Terminal Connections

This section describes connections for the RS-232 (DF1) versions of the PanelView terminal including:

- compatible controllers
- RS-232 terminal ports
- connecting to a controller (point-to-point)
- using a modem
- connecting to a DeviceNet or EtherNet/IP network

TIP

For PanelView 300 Micro terminals, refer to page [218](#).

Compatible Controllers

The RS-232 (DF1) terminals support full duplex communication with the following controllers.

- MicroLogix 1000, 1200, 1500 controllers via the communication port.
- ControlLogix, CompactLogix, FlexLogix controller via RS-232 port
- SLC, PLC or MicroLogix 1000, 1200 or 1500 controllers via 1761-Net-DNI modules (for DeviceNet Network).
- SLC 5/03, SLC 5/04, or SLC 5/05 controllers via Channel 0/DF1 port.
- PLC-5/10, PLC-5/12, PLC-5/15, or PLC-5/25 controllers via bridge such as the 1770-KF2, or 1785-KE.
- Enhanced PLC-5 controllers (for example, PLC-5/11, PLC-5/20, PLC-5/20C, PLC-5/20E) via Channel 0/DF1 port.

RS-232 (DF1) Terminal Ports

The RS-232 (DF1) PanelView terminals, with catalog numbers ending in 17, have a single RS-232 communication port supporting DF1 (Full Duplex) communication port. PanelView terminals with catalog numbers ending in 16 also have an RS-232 printer/file transfer port.

- Use the DF1 port to communicate with a logic controller using DF1 full duplex communication.
- Use the RS-232 printer/file transfer port to transfer applications between a computer and the terminal or to connect a printer. For connection details, see the last section in this chapter.

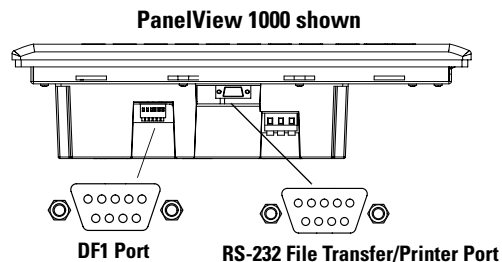

Note: The PanelView 300 has one DF1 port which is used for communication and transferring applications.

RS-232/DF1 Port Connector

The DF1 port on the PanelView terminal is a 9-pin, male, RS-232 connector. The table below shows the pinout descriptions for this port and how these pins map to the DF1 ports on the controllers.

DF1 Port 9-pin DCE		SLC 9-pin	PLC 25-pin	MicroLogix/ DNI 8-pin DIN
1				
2	RXD →	2	3	4
3	← TXD	3	2	7
4	← DTR	4	20	
5	← COM →	5	7	2
6	→ DSR	6	6	
7	← RTS	7	4	
8	→ CTS	8	5	
9				

The maximum cable length for DF1/full duplex communication is 15.24 m (50 ft).

Connecting to a MicroLogix 1000 Controller

The following shows a point-to-point connection between the RS-232 (DF1) port of the PanelView terminal and a MicroLogix 1000 controller.

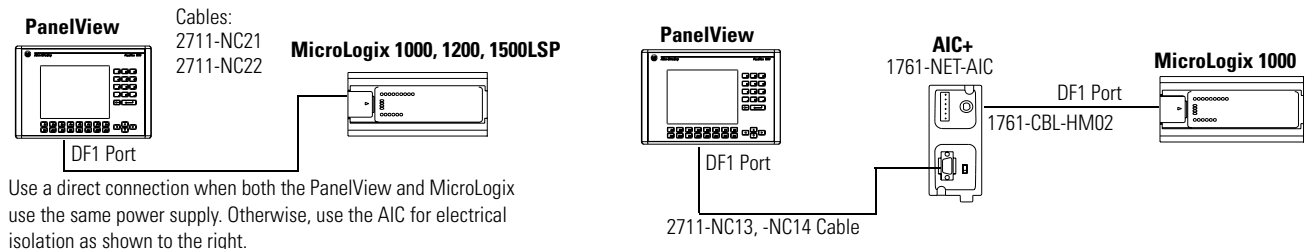

Use a direct connection when both the PanelView and MicroLogix use the same power supply. Otherwise, use the AIC for electrical isolation as shown to the right.

The 1761-NET-AIC module is used only with the MicroLogix controller and eliminates grounding level differences between the controller and PanelView terminal.

Connecting to an SLC, PLC, or MicroLogix 1500LRP Controller

The following shows a point-to-point connection between the DF1 port of the PanelView terminal and an SLC or PLC controller.

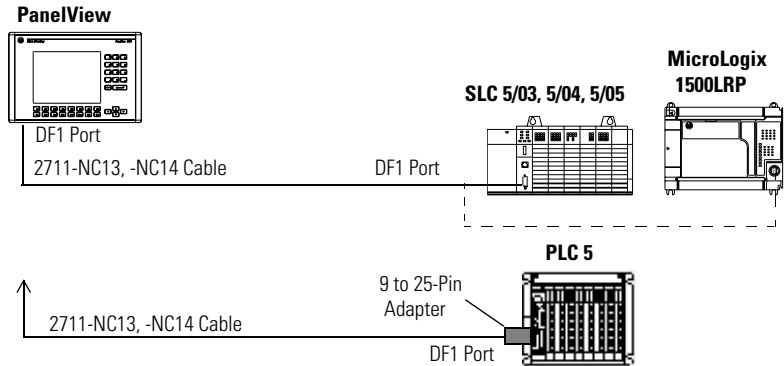

Use an optical isolator or equivalent when grounding level differences exist between the controller or modem and the PanelView.

Connecting to a CompactLogix or FlexLogix

The following shows a point-to-point connection between the DF1 port of the PanelView and a CompactLogix or FlexLogix controller.

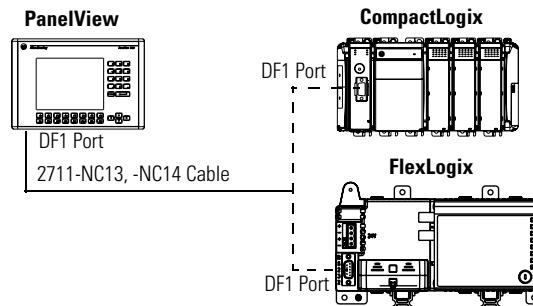

Using a Modem

Wire or radio modem communication is possible between a DF1 terminal and controller. Each modem must support full duplex communication. Refer to your modem user manual for details on settings and configuration.

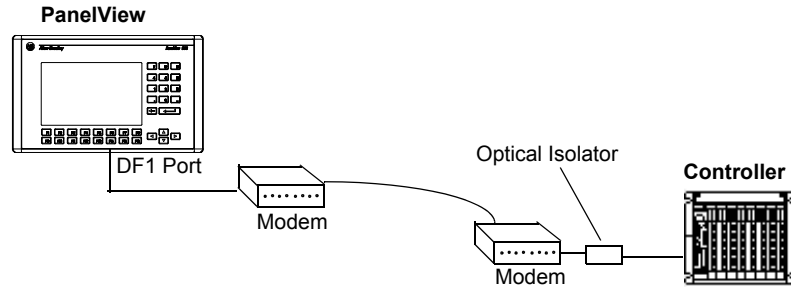

Connecting to a DeviceNet or EtherNet/IP Network

The following illustration shows a DF1 PanelView terminal connected to a single controller (MicroLogix, SLC or PLC) on:

- a DeviceNet network via 1761-NET-DNI modules or
- an EtherNet/IP network via 1761-NET-ENI modules

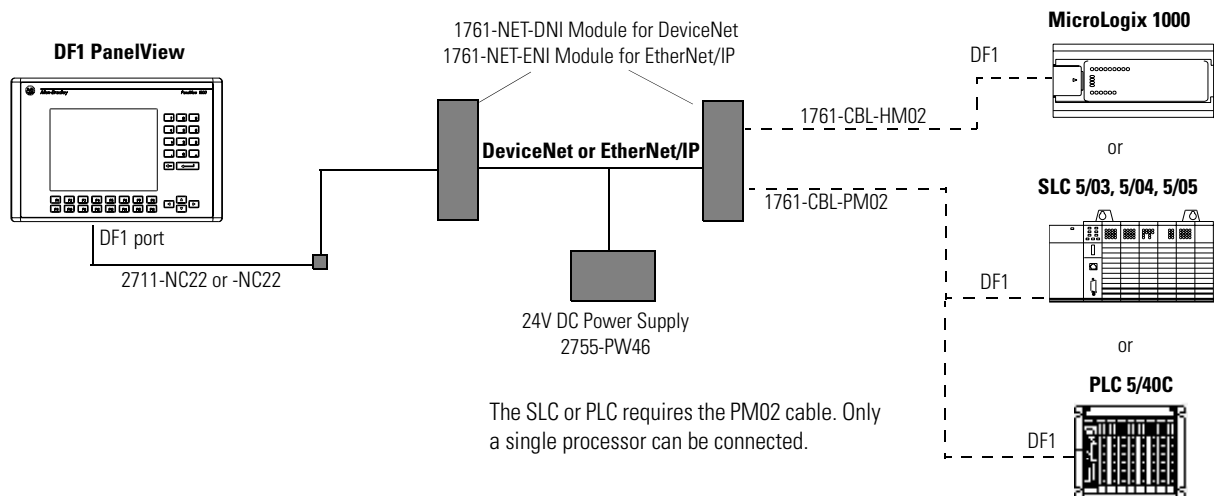

Constructing a Null Modem Cable

To construct a null modem cable, refer to the following pinout:

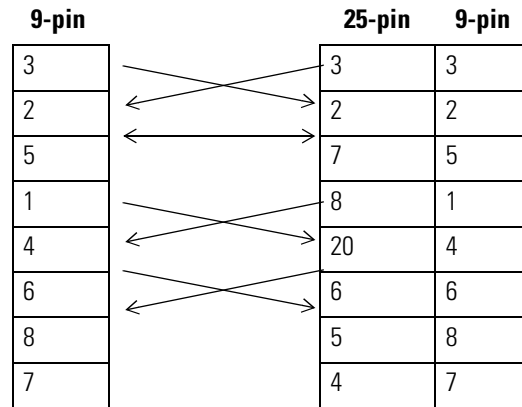

ControlNet Connections

This section describes connections for the ControlNet PanelView terminals including:

- ControlNet Protocol
- Compatible ControlNet Controllers
- ControlNet ports on the PanelView terminal
- Typical ControlNet network
- Making ControlNet connections

Related Information

For more information on ControlNet products, refer to the following publications.

- ControlNet System Overview, publication [NETS-SG001](#)
- ControlNet System Planning and Installation Manual, publication [CNET-IN002](#)
- ControlNet Cable System Component List, publication [AG-PA002](#)

The Allen-Bradley website (www.ab.com) provides information and product descriptions of ControlNet products. Under the Products and Services heading, select Communication.

ControlNet Protocol

The PanelView terminal supports release 1.5 of ControlNet. Scheduled and Unscheduled PLC-5C and ControlLogix messaging. Redundant cabling is supported.

ControlNet allows a flexible control architecture that can work with multiple processors and up to 99 nodes (via taps) anywhere along the trunk cable of the network. There is no minimum tap separation and you can access the ControlNet network from every node (including adapters).

Compatible ControlNet Controllers

The ControlNet PanelView terminal communicates with a PLC-5C (using PCCC commands) or a ControlLogix processor (using CIP protocol) using unscheduled and scheduled messaging. The following controllers are supported:

- ControlLogix using 1756-CNB module
- PLC-5/20C, PLC-5/40C, PLC-5/60C, PLC-5/80C

ControlNet Terminal Ports

ControlNet versions of the PanelView terminal (catalog numbers ending in 15) have a ControlNet communication port and an RS-232 serial port.

- Use the ControlNet port to connect to devices on a ControlNet network and transfer applications over a ControlNet network.
- Use the RS-232 port to transfer applications between a computer and the terminal using a direct connection or to connect a printer.

For details on connecting to the RS-232 port, see the last section in this chapter.

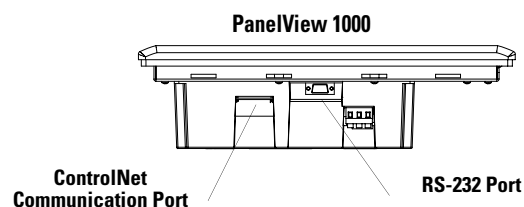

Typical ControlNet Network

Below is a typical ControlNet network with a PanelView terminal installed on a network drop.

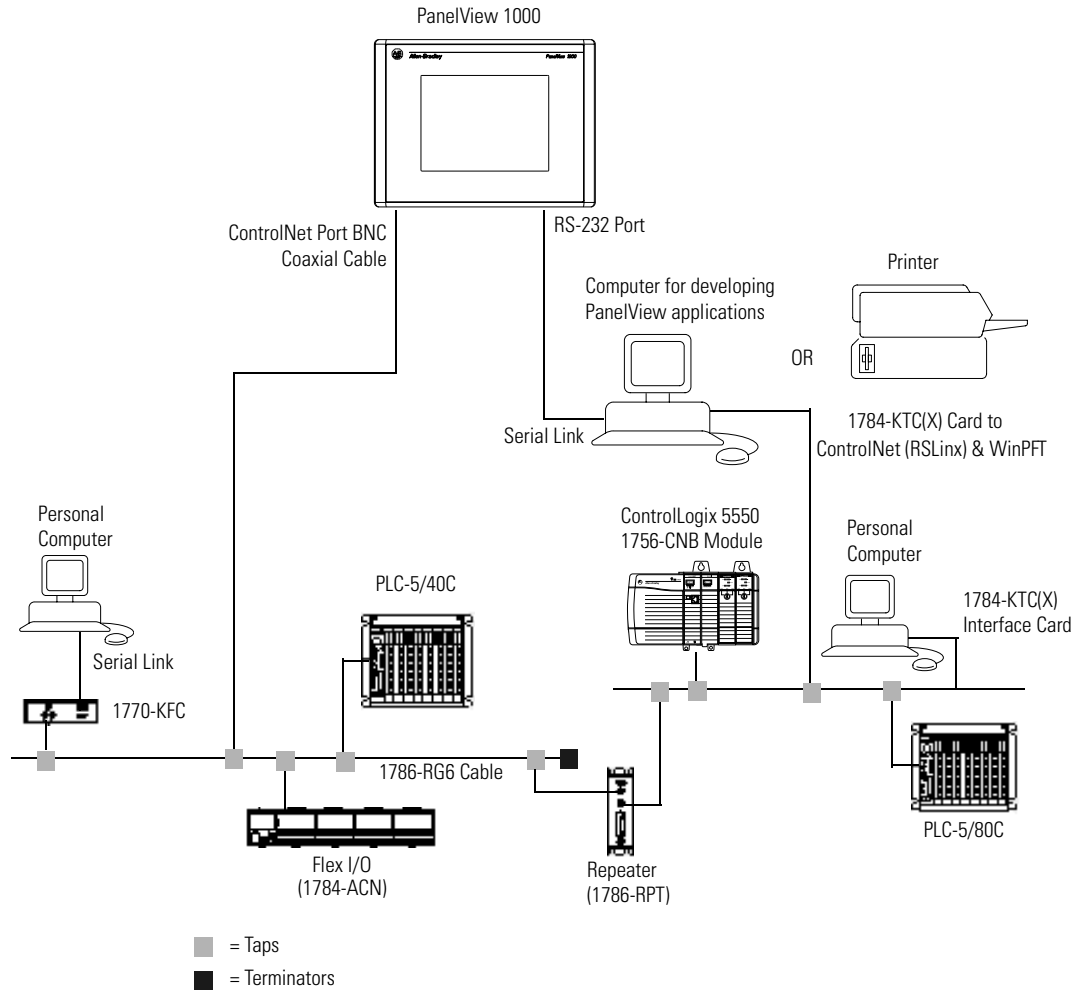

Making ControlNet Connections

Use the pinout information below to connect the PanelView to a ControlNet network.

IMPORTANT

Follow the ControlNet network layout and design as specified in the ControlNet Cable System Planning and Installation Manual, publication [CNET-IN002](#).

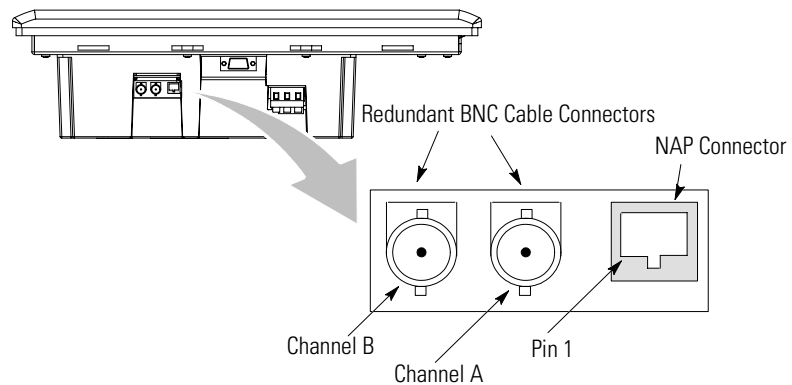

Pin #	NAP Signal
1	Signal Common
2	No Connection
3	TX_H
4	TX_L
5	RX_L
6	RX_H
7	No Connection
8	Signal Common
Shell	Earth Ground

NAP and Redundant Cables

ControlNet cables, taps, connectors. Refer to the ControlNet Cable System Planning and Installation manual, publication [CNET-IN002](#) for descriptions of these components. For information on purchasing these items, refer to the Allen-Bradley ControlNet Cable System Component List, publication [AG-PA002](#).

Item	Catalog Number
RG-6 quad-shield	1786-RG6
Coax repeater	1786-RPT, -RPTD
Coax taps	1786-TPR, -TPS, -TPYR, -TPYS
Network access cable	1786-CP
Coax tool kit	1786-CTK
Segment terminators	1786-XT
BNC connectors	1786-BNC, -BNCJ, -BNCP, -BNCJ1

IMPORTANT

Do not connect to a network using both the redundant cable BNC connector and the Network Access Port (NAP).

DeviceNet Network Terminal Connections

This section describes connections for the DeviceNet PanelView terminals including:

- DeviceNet connectors
- connections
- typical DeviceNet network

DeviceNet Terminal Ports

The DeviceNet versions of the PanelView terminals (catalog numbers ending in 10) have a DeviceNet port and an RS-232 serial port.

- Use the DeviceNet port to connect to devices on a DeviceNet network or transfer applications over a DeviceNet network.
- Use the RS-232 port to transfer applications between a computer and the terminal using a direct connection or to connect a printer.

For details on connecting to the RS-232 port, see the last section in this chapter.

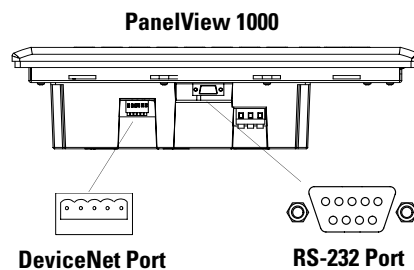

Making DeviceNet Connections

Use one of the cables below to connect the DeviceNet version of the PanelView terminal to a DeviceNet network.

Cable	Publication No.
DeviceNet Cable, 50 m (164 ft)	1485C-P1A50
DeviceNet Cable, 100 m (328 ft)	1485C-P1A150
DeviceNet Cable, 150 m (492 ft)	1485C-P1A300

IMPORTANT

Refer to DeviceNet Cable System Planning and Installation manual, publication [DNET-UM072](#) for network layout and design information

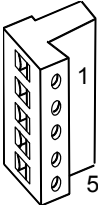
DeviceNet Terminal Block	Terminal	Signal	Function	Color
	1	COM	Common	Black
	2	CAN_L	Signal Low	Blue
	3	SHIELD	Shield	Uninsulated
	4	CAN_H	Signal High	White
	5	V DC+	Power Supply	Red

Typical DeviceNet Network

Below is a typical DeviceNet network with PanelView terminals installed on 2 of the network drops.

A DeviceNet network requires a 24V DC power supply. DeviceNet power consumption is 24...90 mA @24V DC. The PanelView terminal does not receive its power from the network.

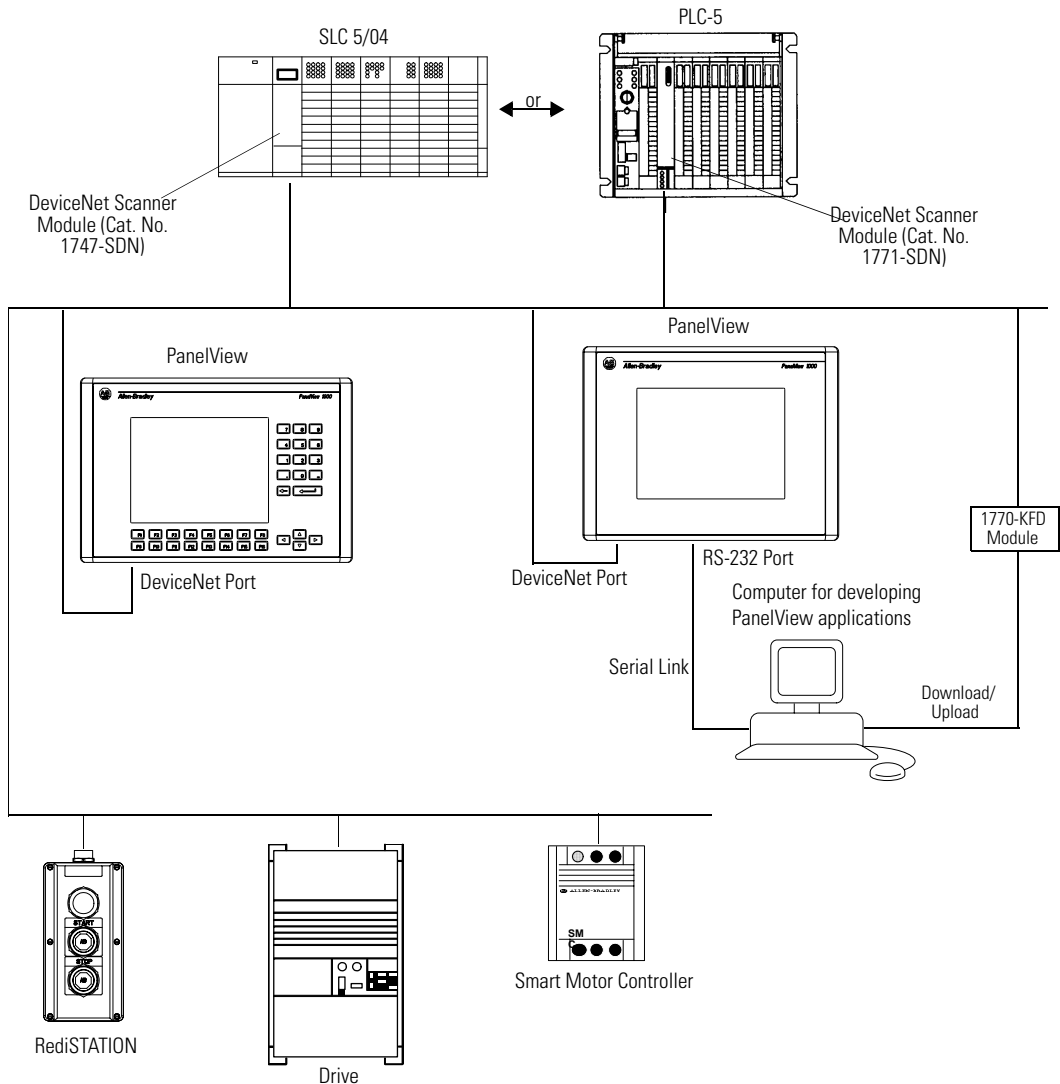

EtherNet/IP Connections

The EtherNet/IP PanelView terminal can communicate on an EtherNet TCP/IP network with the following devices:

- PLC-5E or PLC-5 with 1761-NET-ENI or 1785-ENET module
- SLC-5/05 or SLC with 1761-NET-ENI module
- ControlLogix controller with 1756-ENET/B or 1761-NET-ENI module
- MicroLogix, CompactLogix, or FlexLogix with 1761-NET-ENI module
- Another EtherNet/IP PanelView terminal
- Any device that can process CIP messages

The PanelView terminal supports access to multiple ControlLogix controllers through:

- a single 1756-ENET/B module in a single 1756-I/O rack.
- multiple 1756-ENET/B modules in a single 1756-I/O rack.
- multiple 1756-ENET/B modules in multiple 1756-I/O racks.

EtherNet/IP Terminal Ports

The EtherNet/IP versions of the PanelView terminals (catalog numbers ending in 20) have an Ethernet RJ45 communication port and an RS-232 serial port.

- Use the RJ45 port to communicate with a logic controller on an EtherNet/IP network and transfer applications over an EtherNet/IP network.
- Use the RS-232 serial port to transfer applications between a computer and the terminal using a direct connection or to connect a printer. For connection details, see the last section in this chapter.

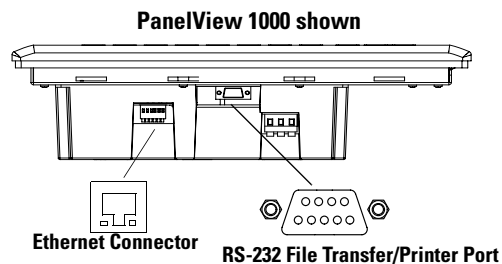

Ethernet Connector

The Ethernet connector is an RJ45, 10/100Base-T connector. This is the pinout for the connector.

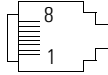
Pin	Pin	Pin Name
RJ45 Connector 	1	TD+
	2	TD-
	3	RD+
	4	NC
	5	NC
	6	RD-
	7	NC
	8	NC

When to use a straight-through and cross-over pin-out:

- Direct point-to-point 10/100Base-T cables, with cross over pin-out (1-3, 2-6, 3-1, 6-2), connect the PanelView Ethernet port directly to another SLC 5/05 Ethernet port (or a computer 10/100Base-T port).

Cables

Category 5 shielded and unshielded twisted-pair cables with RJ45 connectors are supported. The maximum cable length between the PanelView Ethernet port and a 10/100Base-T port on an Ethernet hub (without repeaters or fiber) is 100 m (328 ft). However, in an industrial application, the cable length should be kept to a minimum.

ATTENTION



If you connect or disconnect the Ethernet cable with power applied to the PanelView or any device on the network, an electrical arc can occur. This could cause an explosion in hazardous location installations. Be sure that power is removed or the area is nonhazardous before proceeding.

Typical EtherNet/IP Configuration

The following illustration shows a ControlLogix Controller (with 1756-ENET/B modules), a PLC-5E controller, SLC 5/05, a MicroLogix/CompactLogix/FlexLogix (with 1761-NET-ENI module), and an Ethernet PanelView terminal connected to an EtherNet/IP network. Note that each node has a unique IP address.

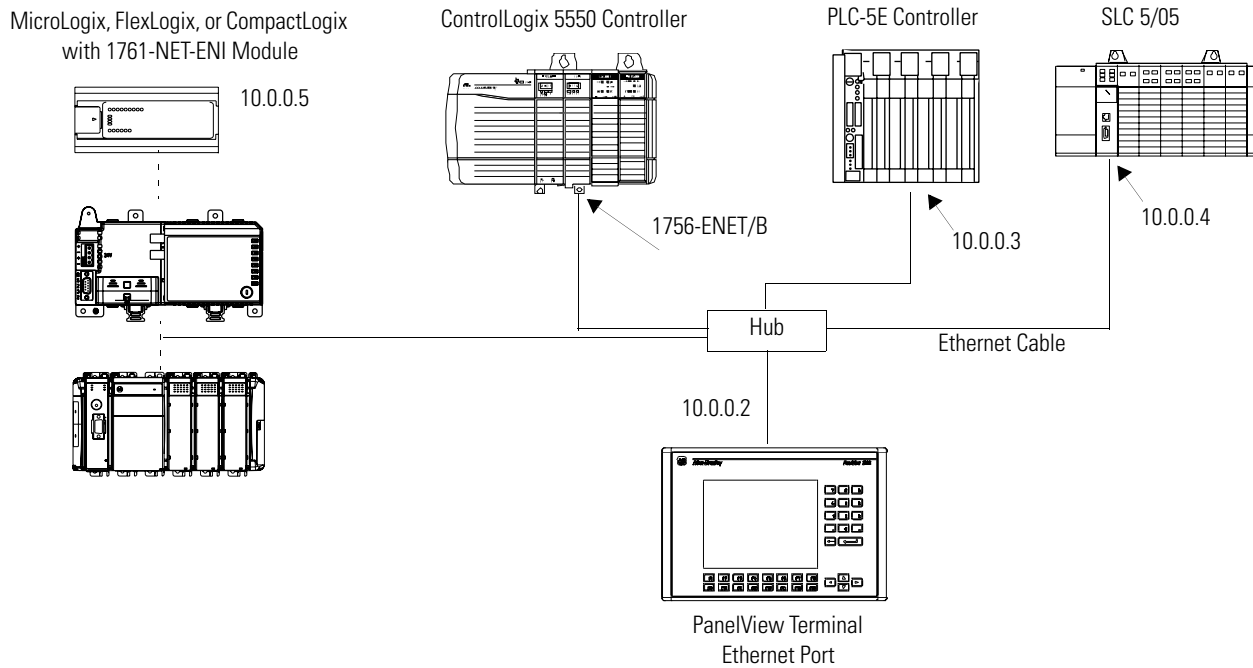

PanelView 300 Micro Terminal Connections

This section describes how to connect the PanelView 300 Micro terminal. Refer to the following topics in this section:

- RS-232 communication port
- Connecting to a MicroLogix Controller
- Connecting to a SLC, PLC-5, ControlLogix, MicroLogix, CompactLogix, or FlexLogix Controller
- Connecting to a DH-485 Network
- Connecting to a DeviceNet Network
- Connecting to a personal computer

RS-232 Communication Port

The PanelView 300 Micro terminal (catalog numbers ending in 18 and 19) has a single RS-232 communication port (8-pin mini DIN).

PanelView 300 Micro

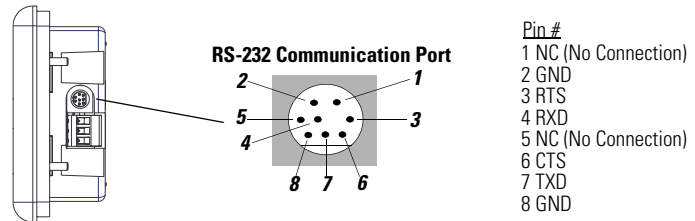

Connecting to a MicroLogix Controller

Directly connect the PanelView 300 Micro terminal to a MicroLogix 1000/1200/1500 controller using the following cables. Use DH-485 or DF1 protocols for communication.

PanelView 300 Micro

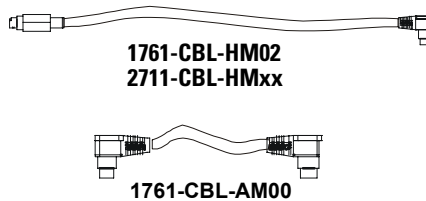
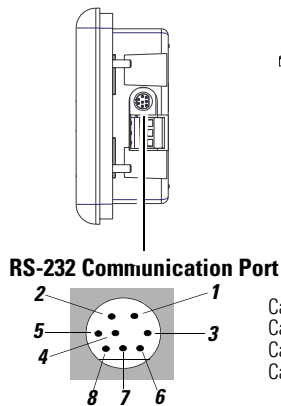

MicroLogix 1000 Shown

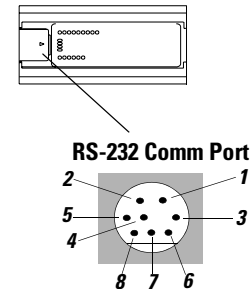

Cable, Catalog No. 1761-CBL-AM00, Series C (.5 m, 1.5 ft)
 Cable, Catalog No. 1761-CBL-HM02, Series C (2 m, 6.5 ft)
 Cable, Catalog No. 2711-CBL-HM05, Series C (5 m, 15 ft)
 Cable, Catalog No. 2711-CBL-HM10, Series C (10 m, 30 ft)

Cable Connector	Pin #	Cable Connector	Pin #
24V	1	1	24V
GND	2	2	GND
RTS	3	3	RTS
CTS	6	6	CTS
DCD	5	5	DCD
RXD	4	4	RXD
TXD	7	7	TXD
GND	8	8	GND

Connecting to an SLC, PLC-5, ControlLogix, MicroLogix 1500LRP, CompactLogix, or FlexLogix

Directly connect the PanelView 300 Micro terminal to an SLC, PLC-5 ControlLogix, MicroLogix 1500LRP, CompactLogix, or FlexLogix processor using the following cables. Use DH-485 (SLC only) or DF1 protocols for communication.

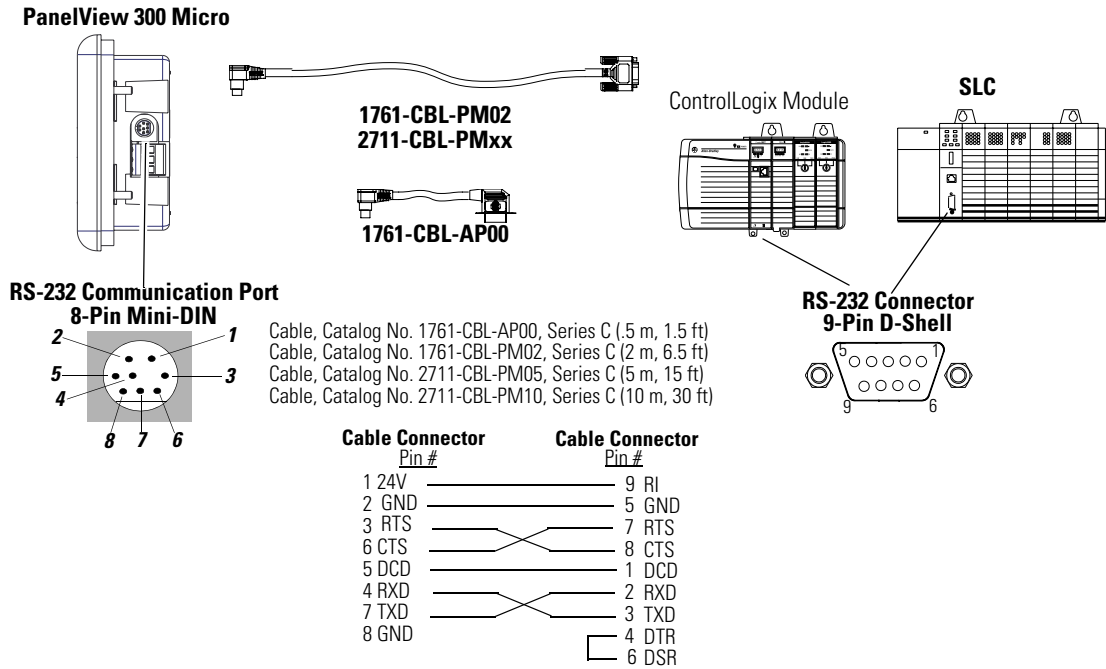

Connecting to an Advanced Interface Converter

DH-485 versions of the PanelView 300 Micro can operate on a DH-485 network through an Advanced Interface Converter (AIC+) module. Use the following cables.

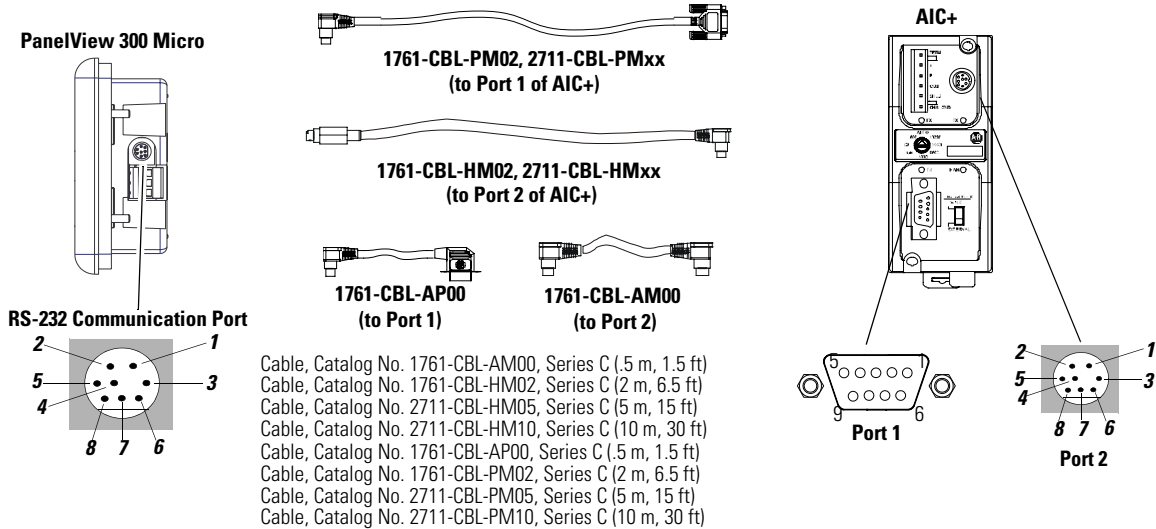

Refer to previous sections for cable diagrams.

Connecting to a DeviceNet Interface (DNI)

Operate the PanelView 300 Micro on a DeviceNet network using DF1 protocol through a point-to-point connection to a DNI module.

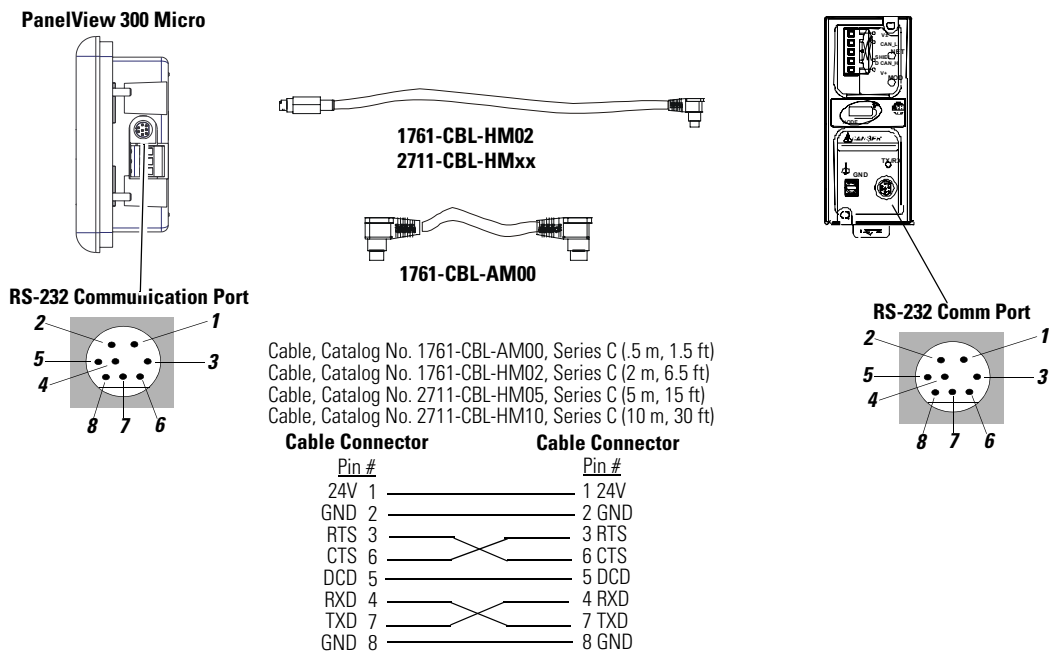

Connecting to a Personal Computer (Application File Transfers)

Transfer applications between a computer and PV300 Micro terminal using one of the following cables.

TIP

Applications for the PanelView 300 Micro terminal are developed using PanelBuilder32 Software (Catalog No. 2711-ND3, V3.60 or later).

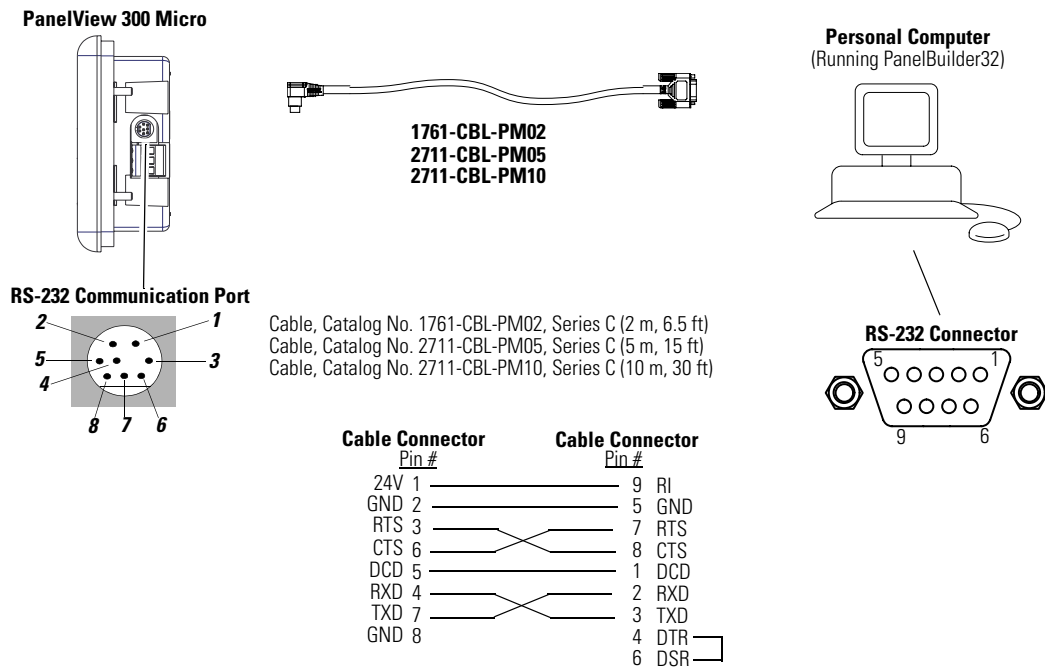

Refer to the PanelBuilder32 software user manual for application download instructions. Here's a short summary of the methods that can be used to transfer files to a PanelView 300 Micro terminal.

PanelBuilder32 Software

Supports the direct transfer of application files from PanelBuilder32 using an RS-232 link.

Windows PanelView File Transfer (WinPFT) Utility

Supports the direct transfer of PanelBuilder32 application files from WinPFT over an RS-232 link. The WinPFT utility is included with the PanelBuilder32 Software. RSLinx software may be required to transfer applications to the terminal for DH-485 and DF1 protocols.

This method is recommended for direct downloads to installed PanelView 300 Micro terminals using a portable or laptop computer.

Windows CE Pocket PanelView File Transfer (PocketPFT) Utility

Supports the direct transfer of PanelBuilder32 application files from the PocketPFT software over an RS-232 link. The PocketPFT software and an RS232 cable is available from Rockwell Software as part of the MaintenCE suite of tools. You will also need one of the recommended download cables.

This method is recommended for direct downloads to installed PanelView 300 Micro terminals using an HPC JORNADA portable CE computer, available only from Rockwell Software.

IMPORTANT

After a successful download of an application, you may not be able to download another application. The downloaded application may have different communication settings than the settings in PanelBuilder32 software. Either change the terminal settings using the Communication Setup screen (see [page 72](#)) or the Application settings dialog in PanelBuilder 32 software.

Connecting a Computer or Printer to the Terminal

Most of the PanelView terminals have an RS-232 serial port to:

- download/upload applications over a serial link.
- connect a printer that supports the IBM enhanced character set.

PanelView terminals that don't have an additional RS-232 Printer Port include the 300 Micro, the 300 (except for DeviceNet), and the -xxA2/-xxA5 versions of the 550/600 and 900 monochrome terminals.

The illustration below shows how to make these connections.

Communication parameters for the RS-232 port are set on the Printer Setup screen of the Configuration Mode menu.

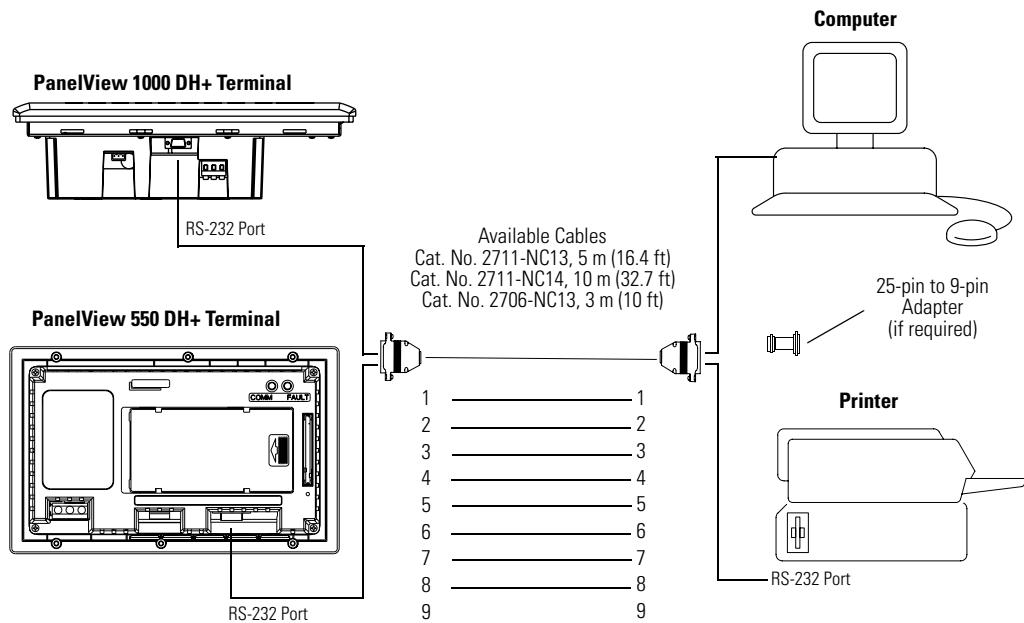

PV550 Printer Port (DCE)
without Handshaking
9-pin male

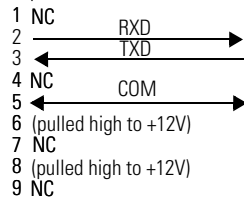

PV600/900/1000/1400 Printer Port (DCE)
9-pin male

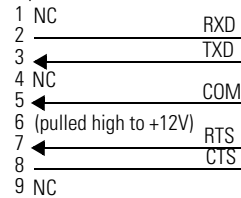

Printer/Computer Port (DTE)
with Handshaking
9-pin female

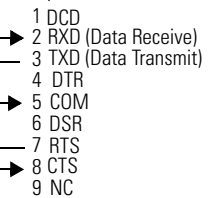

Upload/Download or Printer Cable without Hardware Handshaking

PV550 Printer Port (DCE)
9-pin male

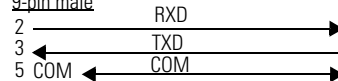

Printer/Computer Port (DTE)
9-pin 25-pin



Troubleshooting and Maintenance

Chapter Objectives

This chapter tells how to isolate and correct common operating problems and perform routine maintenance tasks.

- Using required equipment
- Using troubleshooting chart
- Interpreting status indicators
- Cleaning display window
- Replacing clock module
- Replacing backlight

TIP

You cannot access the PanelView 300 Micro terminal's internal components. The rear cover is not removable; do not attempt to remove the cover. The real-time clock battery and LCD display backlight are not replaceable.

Equipment Required

Use a voltmeter to verify that the correct power source is connected to the terminal. No other electronic diagnostic equipment is required for troubleshooting.

Use the Troubleshooting Chart

The following pages provide a troubleshooting chart for the terminal. This chart lists the most common operating problems, causes, and steps to correct them.

ATTENTION



The PanelView terminals contain hazardous voltages. Do not insert objects or let objects fall into the terminal through ventilation slots. Always disconnect power when checking wiring connections. Failure to take adequate precautions may result in electrical shock.

Troubleshooting Chart

Problem	Probable Causes	Corrective Actions
Terminal does not power up.	Improper connection to power source.	Verify wiring and connections to power source.
	Incorrect input voltage level.	Verify correct voltage is present at power terminals.
	The dc power wires reversed (dc terminals only).	Make sure dc power positive and negative are connected to the proper terminals.
	Power terminal block not fully seated (PV300 terminals only).	Verify power terminal block is snapped onto base of PV300 Micro.
Application file will not download (first download).	Communication cable disconnected.	Check communication cable type and connections.
	Incorrect communication rate or communication settings.	Verify computer and terminal are set to same communication settings.
	Incorrect computer COM port selection.	Verify correct COM port number in WinPFT or PanelBuilder32 software.
Application file will not download (subsequent downloads).	Incorrect communication or communication rate settings.	Verify computer and terminal have same communication settings. Change settings in Communication Setup screen of the terminal.
No communication with MicroLogix, ControlLogix, SLC or PLC controller.	Communication (COMM) fault.	Check status of COMM Status. Verify cable connections using cable diagrams in Chapter 12 .
	Communication rates not set properly.	Verify that terminal and controller are set at the same communication rate.
	Controller is not in run mode.	Place controller in run mode.
	Terminal node and maximum node numbers are not set correctly.	Verify node address settings.
No communication with PLC but COMM Status is active.	PanelView is trying to communicate with a controller at a different address.	Verify address of the controller.
	The inhibit bit is set as the default on the Channel Status Screen in the PLC.	Change setting of the inhibit bit.
No communication with computer.	Communication (COMM) fault.	Check status of COMM Status. Verify cable connections using cable diagrams in Chapter 10 .
	No SLC, network, or power supply connection at terminal's DH-485 port.	Personal Computer Interface Converter (PIC) receives power from DH-485 connection. Verify that the terminal is connected to an SLC, network, or wallmount power supply as shown in Chapter 12 .
	Communication rates not set correctly.	Verify that terminal and computer are set at the correct communication rate.
	Terminal node and maximum node numbers are not set correctly.	Verify node number settings.
	Computer fault.	Refer to user manual for computer.
	Communication driver not properly loaded.	Refer to RSLinx online help or manual.
	Printer port is enabled.	Disable printing on the Printer Setup screen of the Configuration Mode menu.

Troubleshooting Chart

Problem	Probable Causes	Corrective Actions
Clock Module Battery Low message is displayed.	Internal parameters corrupt.	Reload application and cycle power to the terminal.
	Clock module battery failure.	Replace clock module as described in instructions provided with clock module kit. For PanelView 300 Micro, clock module cannot be replaced.
Cannot transfer application from memory card.	Memory card is not properly installed.	Verify correct installation.
	Application is too large for terminal memory.	Reduce size of application file.
	Data checksum is incorrect.	Check that memory card is properly seated. Application may be corrupt.
	Invalid file format.	Verify file format (.PVA) being transferred.
Cannot transfer application to memory card.	Memory card is not properly installed.	Verify correct installation.
	Memory card is write protected. ⁽¹⁾	Change memory card protection switch.
	File currently exists on memory card. ⁽¹⁾	Erase and reformat card.
	Application file is too large, not enough space on memory card.	Reduce size of application file or erase/format memory card.
	Invalid memory card format. ⁽¹⁾	Replace or reformat memory card. If problem continues, try another card.
	Data checksum is incorrect.	Check that card is installed correctly. If problem continues, try another card.
	Application does not exist. ⁽¹⁾	Check the Terminal Info screen to verify that an application exists.
Screen objects do not function. ⁽¹⁾	Terminal not communicating with controller.	Check status of COMM Status indicator. See problem No communication with SLC or PLC controller for more information.
	Terminal in screen saver mode.	Access Screen Setup from the terminal Configuration Mode to check if terminal is in Screen Saver Mode.
Application file name appears as ***** on Terminal Info screen.	Application is invalid.	Download application and try again.
	Application is unusable because of error.	Download new application.
Area on color screen appears dark.	One of the backlight tubes has burnt out.	Replace color backlight.
Screen objects are not visible.	Correct power is not applied.	Verify power connections.
	Contrast or intensity is not set correctly.	Access Screen Setup on the Configuration Mode menu and adjust the contrast. On keypad terminals, press the left and right arrow keys simultaneously, then press [F9] or [F15].
	Terminal is in screen saver mode.	Access Screen Setup on the Configuration Mode menu to see if terminal is set for screen saver mode.
	PV550 backlight lamp is not on.	Access Screen Setup on the Configuration Mode menu and turn on backlight.
	Terminal's backlight is burnt out.	Replace backlight.

Troubleshooting Chart

Problem	Probable Causes	Corrective Actions
Values do not update on display but appear as asterisks ****	Terminal is not communicating with controller.	Check status of COMM Status indicator. Refer to problem No communication with SLC or PLC controller for more details.
	Value is invalid or exceeds the field width defined for the object.	Change the field width for the object.
Can't enter Configuration Mode when pressing Left and Right arrow keys simultaneously.	Left and right arrow keys are assigned to screen objects in the terminal application.	Contact Allen-Bradley technical support for assistance.

⁽¹⁾ Terminal displays a warning message with instructions if these errors occur.

Interpret Status Indicators

On PanelView terminals (except PanelView 300 Micro), use the COMM and Fault Status indicators to isolate operating problems. The illustration below shows the location of these indicators on some terminals.

See [Chapter 1](#) for status indicator locations on other terminals.

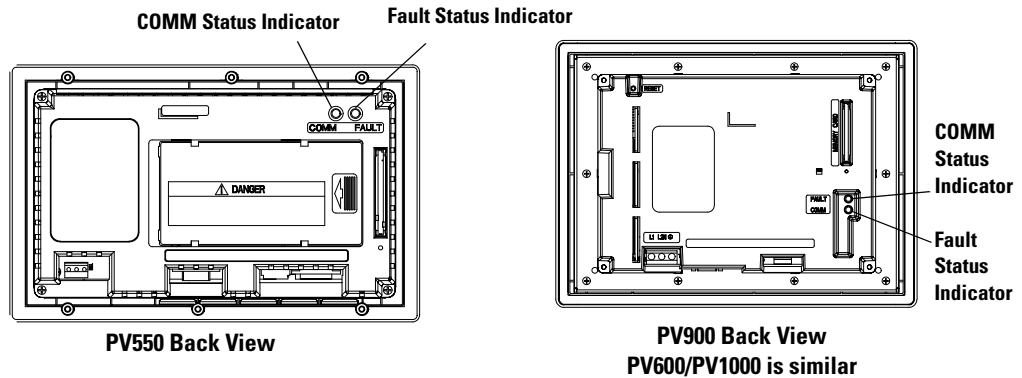

On PanelView 300 Micro terminals, view the Comm and Fault indicators in the terminal configuration mode (Communication Setup selected).

DF1, DH-485, and DH+ Status Indications

Status Indicator	This Pattern	Indicates
Comm ⁽¹⁾	Solid Fill	Normal operating state (no communication faults).
	No Fill	Fault detected. <ul style="list-style-type: none"> • Make sure controller is run mode • Verify baud settings of terminal and controller • Verify proper terminal to controller connections
	Flashing	When power is first applied (momentarily).
	Blinking	No communication established. For DF1 terminals, the Comm indicator flashes until an application is loaded.
Fault	No Fill	Normal operating state
	Solid	Fault detected. Cycle power to the terminal. If the fault still exists, the terminal requires servicing.
	Blinking	Hardware is functioning but no application is loaded or the current application is corrupt. Reload the application into the terminal.

⁽¹⁾ Comm Status indicator stays on until powerup self-tests are complete.

Remote I/O Status Indications

Status Indicator	This pattern	Indicates
Comm ⁽¹⁾	Solid Fill	Normal operating state (no communication faults)
	No Fill	Communication not functioning <ul style="list-style-type: none"> • Verify that baud rate and rack settings match the PLC settings • Verify proper terminal to controller connections • Verify that the PLC enables remote I/O communication
	Blinking	No communication established. PLC is in program mode.
	Flashing	When power is first applied (momentarily)
Fault	No Fill	Normal operating state
	Solid Fill	Fault detected. Cycle power to the terminal. If the fault still exists, the terminal requires servicing.
	Blinking	Hardware is functioning but no application is loaded or the current application is corrupt.

⁽¹⁾ Comm Status indicator stays on until powerup self-test are complete

DeviceNet, ControlNet, and EtherNet/IP Network Indicators

Status Indicator	This Pattern	Indicates
Comm	Solid Fill	Normal operating state (no communication faults).
	No Fill	Hardware failed.
	Flashing	When power is first applied (momentarily).
	Blinking	No communication established.
Fault	Solid Fill	Hardware failed.
	No Fill	Normal operating state (no communication faults).
	Blinking	Hardware is functioning but no application is loaded or the current application is corrupt.

Clean the Display Window

Follow these steps to clean the display window.

ATTENTION

Use of abrasive cleansers or solvents may damage the window. Do not scrub or use brushes.

1. Disconnect power from the terminal at the power source.
2. Use a clean sponge or a soft cloth to clean the display with a mild soap or detergent.
3. Dry the display with a chamois or moist cellulose sponge to avoid water spots.

Remove Paint and Grease

Remove fresh paint splashes and grease before drying by rubbing lightly with isopropyl alcohol (70% concentration). Afterward, provide a final wash using a mild soap or detergent solution. Rinse with clean water.

Equipment Hose-downs

Be aware that screen objects on touch cell terminals may activate during equipment hose-downs.

ATTENTION

Because touch terminals have sensitive touch cell regions, it is possible for screen objects to activate during equipment hose-downs.

Replace the Clock Module

The real-time clock (RTC) module contains a lithium battery used only by the real-time clock. The battery is not used for application backup or input retention. The clock module has a typical life expectancy of seven years.

TIP

The real-time clock on the PanelView 300 Micro terminal is not replaceable.

The clock module replacement kits for the PanelView terminals are listed on [page 56](#) under [Replacement Parts](#). Replacement instructions are provided with the kits.

ATTENTION



The clock module contains lithium. Do not attempt to dispose of the module in a fire or incinerator. Doing so may cause the clock module to explode. Follow disposal regulations in your area for lithium battery disposal.

Replace the Backlight

Replacement backlights are available for the PanelView terminals.

See [Replacement Parts](#) on [page 56](#) for the catalog numbers. Replacement instructions are provided with the kits.

TIP

The backlight on the PanelView 300 and 300 Micro terminal, the PanelView 550 (series H and above) keypad and 550 (series B) touch screen, and PanelView 600 touch screen is not replaceable.

ATTENTION



The PanelView 600 and PanelView 1000 LCD backlights contain mercury. At the end of its life, this equipment should be collected separately from any unsorted municipal waste.

Specifications

PanelView 300 Micro Terminal

Electrical	
DC Power Supply Voltage Limits Power Consumption	11...30V DC (24V nominal), Class 2 Power Supply 2.5 W maximum (0.105A @24V DC)
Mechanical	
Enclosure	NEMA Type 12/13, 4X (Indoor use only), IP54, IP65
Weight	284 g (10 oz.)
Dimensions mm inches	133 (H) x 112 (W) x 48 (D) 5.23 (H) x 4.38 (W) x 1.87 (D)
Installed Depth	35mm (1.39 in.)
Display	
Type	Liquid Crystal Display (LCD) with integral LED backlight (100,000 hour life)
Size	73 mm (w) x 42 mm (h) 2.87 in. (w) x 1.67 in. (h)
Pixels	128 x 64
Terminal Memory	
Total Application Flash Memory	240K bytes (application screens)
Environment	
Operating Temperature	0...55 °C (32...131 °F)
Storage Temperature	-20...85 °C (-4...188 °F)
Relative Humidity (noncondensing)	5...95% at 0...55 °C (32...131 °F)
Heat Dissipation	2.5 Watts (8.5 BTU/Hour)
Shock (operating, nonoperating)	30 g/50 g
Vibration (operating)	2 g up to 2,000 Hz

Character Sizes (Pixel size = 0.48 x 0.48 mm)

Size in Pixels width x height)	Characters/Row	Maximum Rows	Dimensions in mm Width x Height
4 x 6	31	10	1.9 x 2.9
6 x 8	20	7	2.9 x 3.8
6 x 16	20	3	2.9 x 7.7
6 x 24	20	2	2.9 x 11.5
12 x 8	10	7	5.8 x 3.8
12 x 16	10	3	5.8 x 7.7
12 x 24	10	2	5.8 x 11.5
18 x 8	6	7	8.6 x 3.8
18 x 16	6	3	8.6 x 7.7
18 x 24	6	2	8.6 x 11.5

PanelView 300 Terminal

Electrical

DC Power Supply Voltage Limits Power Consumption	18...32V DC (24V DC nominal), Class 2 Power Supply 6 Watts (0.25 Amps at 24V DC)
--	---

Mechanical

Enclosure	NEMA Type 12/13, 4X (Indoor use only), IP54, IP65
Status Indicators COMM Fault	Green Red
Weight	673 g (1.48 lb)
Dimensions mm in	197 (H) x 140 (W) x 82 (D) 7.76 (H) x 5.53 (W) x 3.21 (D)
Installed Depth	69 mm (2.73 in.) 122.4 mm (4.82 in.) with memory card retainer 216 mm (8.5 in.) with memory card retainer and clearance to insert and remove memory card

Display	
Type	Liquid Crystal Display (LCD) with integral LED backlight (100,000 hour life)
Size	73 mm (w) x 42 mm (h) 2.87 in. (w) x 1.67 in. (h)
Pixels	128 x 64

Terminal Memory	
Total Application Flash Memory	240K bytes (application screens)

Environment	
Operating Temperature	0...55 °C (32...131 °F)
Storage Temperature	-25...85 °C (-4...188 °F)
Relative Humidity (non-condensing)	5...95% at 0...55 °C (32...131 °F)
Heat Dissipation	6 Watts (13 BTU/HR)
Shock (operating/non-operating)	15 g/30 g
Vibration (operating)	2 g up to 2,000 Hz
Airborne Contaminants ⁽¹⁾	ANSI/ISA-S71.04-1985 severity level G3, reference EN60654-4:1998 Class 3

⁽¹⁾ Only applicable to conformal coated products: 2711-K3A5L1K.

Character Sizes (Pixel size = 0.48 x 0.48 mm)

Size in Pixels width x height)	Characters/Row	Maximum Rows	Dimensions in mm Width x Height
4 x 6	31	10	1.9 x 2.9
6 x 8	20	7	2.9 x 3.8
6 x 16	20	3	2.9 x 7.7
6 x 24	20	2	2.9 x 11.5
12 x 8	10	7	5.8 x 3.8
12 x 16	10	3	5.8 x 7.7
12 x 24	10	2	5.8 x 11.5
18 x 8	6	7	8.6 x 3.8
18 x 16	6	3	8.6 x 7.7
18 x 24	6	2	8.6 x 11.5

PanelView 550 Terminals

Electrical	
DC Power	
Supply Voltage Limits	18...30V DC (24V DC nominal)
Power Consumption	18 W, max (0.75 A @ 24V DC)
Supply Voltage Limits (touch screen only)	18...32V DC (24V DC nominal)
Power Consumption (touch screen only)	18 W, max (0.75 A @ 24V DC)
AC Power	
Supply Voltage Limits	85...264V AC, 47...63 Hz
Power Consumption	45 VA maximum

Mechanical	
Enclosure	NEMA Type 12/13, 4X (Indoor use only), IP54, IP65
Status Indicators	
COMM	Green
Fault	Red
Weight	
Keypad, Keypad & Touch	1.2 kg (2.7 lb)
Touch Screen	.93 kg (2.1 lb)
Dimensions- Keypad, Keypad & Touch	
mm	167 (H) x 266 (W) x 106 (D)
in	6.57 (H) x 10.47 (W) x 4.17 (D)
Dimensions- Touch Screen	
mm	152 (H) x 185 (W) x 82 (D)
in	6.00 (H) x 7.28 (W) x 3.20 (D)
Installed Depth- Keypad, Keypad & Touch	86 mm (3.39 in.) 118 mm (4.64 in.) with memory card retainer 207 mm (8.15 in.) with memory card retainer and clearance to insert and remove memory card
Installed Depth- Touch Screen	64 mm (2.54 in.) 109 mm (4.30 in.) with memory card retainer 188 mm (7.40 in.) with memory card retainer and clearance to insert and remove memory card

Display	
Type	Liquid Crystal Display (LCD)
Size	120 x 60 mm (4.75 x 2.38 in.)
Pixels	256 x 128
Touch Cells	128 (16 columns x 8 rows)
Touch Cell Size	16 x 16 pixels

Terminal Memory

PV550 (Series E or later) or PV550T (Series A or later) Total Application Flash Memory	240K bytes (application screens)
PV550 (Prior to Series E) Total Application Flash Memory	112K bytes (application screens)

Environment

Operating Temperature	0...55 °C (32...131 °F)
Storage Temperature	-20...70 °C (-4...158 °F)
Relative Humidity (non-condensing)	5...95% at 0...30 °C (32...86 °F) 5...75% at 31...40 °C (88...104 °F) 5...50% at 41...55 °C (106...131 °F)
Heat Dissipation	20 W (69 BTU/HR) for AC Power or DC Power
Shock (operating/non-operating)	30 g/50 g
Vibration (operating)	2 g up to 2,000 Hz

Character Sizes (Pixel size = 0.47 x 0.47 mm)

Size in Pixels width x height	Characters/Row	Maximum Rows	Dimensions in mm Width x Height
6 x 8	40	16	2.2 x 3.2
6 x 16	20	16	3.8 x 5.6
6 x 24	13	16	3.8 x 8.4
12 x 8	40	8	7.6 x 2.8
12 x 16	20	8	7.6 x 5.6
12 x 24	13	8	7.6 x 8.4
18 x 8	40	5	11.2 x 2.8
18 x 16	20	5	11.2 x 5.6
18 x 24	13	5	11.2 x 8.4

PanelView 600 Color Keypad and Touch Terminals

Electrical	
AC Power Supply Voltage Limits Power Consumption	85...264V AC, 43...63 Hz 60 VA maximum
DC Power Supply Voltage Limits Power Consumption	18...32V DC (24V DC nominal) 24 W max. (1.0A @ 24V DC)
Mechanical	
Enclosure	NEMA Type 12/13, 4X (Indoor use only), IP54, IP65
Status Indicators COMM Fault	Green Red
Weight	2 kg (4.4 lb)
Dimensions mm in	192 (H) x 290 (W) x 116 (D) 7.55 (H) x 11.40 (W) x 4.57 (D)
Installed Depth	99 mm (3.89 in.) 131 mm (5.14 in.) with memory card retainer 220 mm (8.65 in.) with memory card retainer and clearance to insert and remove memory card
Display	
Type	Active Matrix Thin-Film Resistor (TFT) with Cold Cathode Fluorescent (CCF) Backlight
Size	115 x 86 mm (4.54 x 3.4 in.)
Pixels	320 x 234
Touch Cells	128 (16 columns x 8 rows)
Touch Cell Size	20 x 29 pixels
Terminal Memory	
Total Application Flash Memory	240K bytes (application screens)
Environment	
Operating Temperature	0...55 °C (32...131 °F)
Storage Temperature	-25...70 °C (-13...158 °F)
Relative Humidity (noncondensing)	5...95% at 0...55 °C (32...131 °F)
Heat Dissipation	32 Watts (107 BTU/HR) for AC or DC Power
Shock (operating/nonoperating)	15 g/30 g
Vibration (operating)	2 g up to 2,000 Hz

Character Sizes (Pixel size = 0.36 x 0.37 mm)

Size in Pixels width x height)	Characters/Row	Maximum Rows	Dimensions in mm Width x Height
6 x 9	52	25	2.9 x 5.9
8 x 16	39	14	2.9 x 5.9
8 x 24	39	9	2.9 x 8.9
16 x 24	19	9	5.8 x 8.9
24 x 32	13	7	8.6 x 11.8
32x 40	9	5	11.5 x 14.8

PanelView 600 Color Touch Only Terminals

Electrical

DC Power Supply Voltage Limits Power Consumption	18...32V DC (24V DC nominal) 24 W max (1.0A @ 24V DC)
--	--

Mechanical

Enclosure	NEMA Type 12/13, 4X (Indoor use only), IP54, IP65
Status Indicators COMM Fault	Green Red
Weight	1 kg (2.3 lb)
Dimensions mm in	152 (H) x 185 (W) x 96 (D) 6.00 (H) x 7.28 (W) x 3.80 (D)
Installed Depth	79 mm (3.12 in.) 132 mm (5.21 in.) with memory card retainer 211 mm (8.30 in.) with memory card retainer and clearance to insert and remove memory card

Display

Type	Active Matrix TFT with Cold Cathode Fluorescent (CCF) Backlight
Size	115 x 87 mm (4.54 x 3.43 in.)
Pixels	320 x 240
Touch Cells	128 (16 columns x 8 rows)
Touch Cell Size	20 x 30 pixels
Backlight	50,000 hours, 1/2 life at 25 °C (77 °F)

Terminal Memory	
Total Application Flash Memory	240K bytes (application screens)

Environment	
Operating Temperature	0...50 °C (32...122 °F)
Storage Temperature	-25...70 °C (-13...158 °F)
Relative Humidity (non-condensing)	5...95% at 0...40 °C (32...104 °F)
Heat Dissipation	17 W (577 BTU/HR)
Shock (operating/non-operating)	15 g/30 g
Vibration (operating)	2 g up to 2,000 Hz

Character Sizes (Pixel size = 0.35 x 0.35 mm)

Size in Pixels width x height)	Characters/Row	Maximum Rows	Dimensions in mm Width x Height
6 x 9	52	25	2.1 x 3.1
8 x 16	39	14	2.8 x 5.6
8 x 24	39	9	2.8 x 8.4
16 x 24	19	9	5.6 x 8.4
24 x 32	13	7	8.4 x 11.1
32x 40	9	5	11.1 x 13.9

PanelView 900 Monochrome and Color⁽¹⁾ Terminals

Electrical	
AC Power - PV900M and PV900C Supply Voltage Limits Power Consumption	85...264V AC, 47...63 Hz 110 VA maximum
DC Power - PV900M Supply Voltage Limits Power Consumption	18...30 V DC (24V DC nominal) 58 W max (2.5 A @ 24V DC)
DC Power - PV900C Supply Voltage Limits Power Consumption	18...32 V DC (24V DC nominal) 50 W max (2.1 A @ 24V DC)

⁽¹⁾ The PanelView 900 specifications are for reference only. PanelView 900 Terminals are n longer available. Contact your Rockwell Automation distributor for more information.

Mechanical	
Enclosure	NEMA Type 12/13, 4X (Indoor use only) IP54, IP65
Status Indicators COMM Fault	Green Red
Weight - PV900M Keypad Touch Screen	3.14 kg (4.4 lb) 2.91 kg (6.4 lb)
Weight - PV900C Keypad Touch Screen	3.18 kg (7.0 lb) 2.95 kg (6.5 lb)
Dimensions - PV900M/900C Keypad mm in	249 (H) x 406 (W) x 112 (D) 9.80 (H) x 15.97 (W) x 4.40 (D)
Dimensions - PV900M/900C Touch Screen mm in	249 (H) x 336 (W) x 112 (D) 9.80 (H) x 13.24 (W) x 4.40 (D)
Installed Depth - PV900M	97 mm (3.81 in.) 129 mm (5.06 in.) with memory card retainer 220 mm (8.65 in.) with memory card retainer and clearance to insert and remove memory card
Installed Depth - PV900C	99 mm (3.89 in.) 131 mm (5.14 in.) with memory card retainer 222 mm (8.73 in.) with memory card retainer and clearance to insert and remove memory card
Display	
PV900M	
Type	AC Gas Plasma
Size	210 x 131 mm (8.27 x 5.17 in.)
Pixels	640 x 400
Touch Cells	384 (24 columns x 16 rows)
Touch Cell Size	26 x 25 pixels
PV900C	
Type	Active Matrix Thin-Film Resistor (TFT) with Cold Cathode Fluorescent (CCF) Backlight
Size	171 x 130 mm (6.73 x 5.12 in.)
Pixels	640 x 480
Touch Cells	384 (24 columns x 16 rows)
Touch Cell Size	26 x 30 pixels

Terminal Memory	
PV900M (prior to Series E) Total Application Flash Memory	240K bytes (application screens)
PV900M (Series E, firmware 3.0 or later), PV900C Total Application Flash Memory	1008K bytes (application screens)

Environment	
PV900M	
Operating Temperature	0...55 °C (32...131 °F)
Storage Temperature	-25...70 °C (-13...158 °F)
Relative Humidity (non-condensing)	5...85% at 0...30 °C (32...86 °F)
Heat Dissipation	50 Watts (165 BTU/HR) for AC Power or DC Power
Shock (operating/non-operating)	15 g/30 g
Vibration (operating)	1 g up to 2,000 Hz
PV900C	
Operating Temperature	0...55 °C (32...131 °F)
Storage Temperature	-25...70 °C (-13...158 °F)
Relative Humidity (non-condensing)	5...95% at 0...55° C (32...131° F)
Heat Dissipation	39 W (133 BTU/HR)
Shock (operating/non-operating)	15 g/30 g
Vibration (operating)	1 g up to 2,000 Hz

Character Sizes PV900M (Pixel size = 0.33 x 0.33 mm)

Size in Pixels width x height)	Characters/Row	Maximum Rows	Dimensions in mm Width x Height
8 x 16	79	24	2.6 x 5.3
8 x 24	79	16	2.6 x 7.9
16 x 24	39	16	5.3 x 7.9
24 x 32	26	12	7.9 x 10.6
32x 40	19	9	10.6 x 13.2

Character Sizes PV900C (Pixel size = 0.27 x 0.27 mm)

Size in Pixels width x height)	Characters/Row	Maximum Rows	Dimensions in mm Width x Height
8 x 16	79	24	2.2 x 4.3
8 x 24	79	19	2.2 x 6.5
16 x 24	39	19	4.3 x 6.5
24 x 32	26	14	6.5 x 8.6
32x 40	19	11	8.6 x 10.8

PanelView 1000 Color & Grayscale

Electrical	
AC Power - PV1000G and PV1000C Supply Voltage Limits Power Consumption	85...264V AC, 47...63 Hz 55 VA maximum
DC Power - PV1000G and PV1000C Supply Voltage Limits Power Consumption	18...32 V DC (24V DC nominal) 24 W max (1.0A @ 24V DC)

Mechanical	
Enclosure	NEMA Type 12/13, 4X (Indoor use only) IP54, IP65
Status Indicators COMM Fault	Green Red
Weight - PV1000G and PV1000C Keypad Touch	3.06 kg (6.7 lb) 3.00 kg (6.6 lb)
Dimensions-PV1000G/1000C Keypad mm in	282 (H) x 423 (W) x 112 (D) 11.11 (H) x 16.64 (W) x 4.40 (D)
Dimensions - PV1000G/1000C Touch Screen mm in	282 (H) x 370 (W) x 112 (D) 11.11 (H) x 14.58 (W) x 4.40 (D)
Installed Depth - PV1000G and PV1000C	97 mm (3.81 in.) 129 mm (5.06 in.) with memory card retainer 220 mm (8.65 in.) with memory card retainer and clearance to insert and remove memory card

Terminal Memory	
Total Application Flash Memory	1008K bytes (application screens)

Display	
PV1000G	
Type	Active Matrix Thin-Film Resistor (TFT) with Cold Cathode Fluorescent (CCF) Backlight (4 shades of gray)
Size	211 x 158 mm (8.3 x 6.2 in.)
Pixels	640 x 480
Touch Cells	384 (24 columns x 16 rows)
Touch Cell Size	26 x 30 pixels
PV1000C	
Type	Active Matrix Thin-Film Resistor (TFT) with Cold Cathode Fluorescent (CCF) Backlight
Size	211 x 158 mm (8.3 x 6.2 in.)

Display	
Pixels	640 x 480
Touch Cells	384 (24 columns x 16 rows)
Touch Cell Size	26 x 30 pixels

Environment	
Operating Temperature	0...55 °C (32...131 °F)
Storage Temperature	-25...70 °C (-13...158 °F)
Relative Humidity (non-condensing)	5...95% at 0...55 °C (32...131 °F)
Heat Dissipation	39 W (132 BTU/HR) for Grayscale and Color
Shock (operating/non-operating)	15 g/30 g
Vibration (operating)	2 g up to 2,000 Hz

Character Sizes PV1000G and 1000C (Pixel size = 0.33 x 0.33 mm)

Size in Pixels width x height)	Characters/Row	Maximum Rows	Dimensions in mm Width x Height
8 x 16	79	24	2.2 x 5.3
8 x 24	79	19	2.6 x 7.9
16 x 24	39	19	5.3 x 7.9
24 x 32	26	14	7.9 x 10.6
32x 40	19	11	10.6 x 13.2

PanelView 1400 Color

Electrical	
AC Power Supply Voltage Limits Power Consumption	85...264V AC, 43...63 Hz 200 VA maximum

Mechanical	
Enclosure	NEMA Type 12/13, 4X (Indoor use only) IP54, IP65
Status Indicators COMM Fault	Green Red
Weight Keypad Touch Screen	20.3 kg (44.75 lbs) 19.6 kg (43.2 lbs)

Mechanical	
Dimensions - PV1400 Keypad mm inches	355 (H) x 483 (W) x 394 (D) 13.97 (H) x 19.0 (W) x 15.53 (D)
Dimensions - PV1400 Touch Screen mm in	355 (H) x 441 (W) x 394 (D) 13.97 (H) x 17.37 (W) x 15.53 (D)
Installed Depth	370 mm (14.58 in.) 400 mm (15.75 in.) with clearance to insert and remove memory card

Terminal Memory	
Total Application Flash Memory	1008K bytes (application screens)

Display	
Type	Color CRT
Size	255 x 191 mm (10.0 x 7.5 in.)
Pixels	800 x 600
Touch Cells	384 (24 columns x 16 rows)
Touch Cell Size	33 x 37 pixels

Environment	
Operating Temperature	0...55 °C (32...131 °F)
Storage Temperature	-40...85 °C (-40...185 °F)
Relative Humidity (non-condensing)	5...95% at 0...55 °C (32...131 °F)
Heat Dissipation	78 W (264 BTU/HR)
Shock (operating/non-operating)	15 g/30 g
Vibration (operating)	1 g up to 2,000 Hz

Character Sizes PV1400 (Pixel size = 0.32 x 0.32 mm)

Size in Pixels width x height)	Characters/Row	Maximum Rows	Dimensions in mm Width x Height
8 x 20	99	29	2.5 x 6.4
16 x 24	49	24	5.1 x 7.6
24 x 32	33	18	7.6 x 10.2
32 x 40	24	14	10.2 x 12.7
32 x 64	24	9	10.2 x 20.4

Communication

DH-485 Network Communication Rate Distance Maximum	1200, 2400, 9600, 19.2K 1219 m (4,000 ft)
DH+ Network Communication Rate Distance Maximum	57.6K, 115.2K, 230.4K 3048 m (10,000 ft)
RS-232 or DH-485 Point-to-Point Communication Rates Distance Maximum	1200, 2400, 9600, 19.2K 6.1 m (20 ft)
Remote I/O Communication Rates	57.6K, 2,800 m (10,000 ft) 115.2K, 1,400 m (5,000 ft)
DeviceNet Communication Rates	125K, 250K, 500K
ControlNet Network Communication Rate Distance Maximum	5M 1,000 m (3,280 ft)
EtherNet/IP Network Distance Maximum	100 meters (328 feet)
DF1/Full Duplex Communication Communication Rate Distance Maximum	1200, 2400, 4800, 9600, 19.2K 15.24 m (50 ft)
RS-232 Printer Port Communication Rates Parity Data Bits Stop Bits Handshaking	1200, 2400, 9600, 19.2K None, Even, Odd 7 or 8 1 or 2 None, Software (XON, XOFF), Hardware

Agency Certifications

	300 Micro	300	550	600	900M	900C	1000G	1000C	1400
Emissions (Class A: Industrial) EN50081-2:1993	x	x	x	x	x	x	x	x	x
Immunity (Industrial) EN61000-6-2:1999	x	x ⁽¹⁾	x ⁽¹⁾	x ⁽¹⁾	x ⁽¹⁾	x ⁽¹⁾	x ⁽¹⁾	x ⁽¹⁾	x ⁽¹⁾
Immunity (Industrial) EN50082-2:1995 ⁽²⁾		x	x	x	x	x	x	x	x
Programmable Controllers Equipment Requirements and Tests) EN61131 2:1995		x	x	x	x	x	x	x	x
Low Voltage Directive (Safety Sections of EN61131-2)			x	x ⁽³⁾	x	x	x	x	x
UL508	x	x	x	x	x	x	x	x	x
UL1604 Class 1, Div 2, Groups A, B, C, D, T4	x	x	x ⁽⁴⁾⁽⁵⁾	x	x	x	x	x	
UL2279 (IEC79-15) Class 1, Zone 2, Groups IIC, T4				x			x	x	
CSA 22.2, No. 142	x	x	x	x	x	x	x	x	x
CSA 22.2, No. 213 Class 1, Div 2, Groups A, B, C, D, T4	x	x	x ⁽⁴⁾⁽⁵⁾	x	x	x	x	x	
EU Batteries Directive, 2006/66/EC	x	x	x	x	x	x	x	x	x

(1) Meets standard as of April 2002.

(2) This standard applies to products manufactured prior to April 2002.

(3) Does not apply to 600 Touch Screen Only terminals

(4) PV550 (Series H or later) or PV550 Touch Screen Only (Series B or later)

(5) PV550 terminals (Series G or earlier) and PV550 Touch Screen (Series A) have a Temperature Code Rating of T2

Messages, Codes and Self-test Numbers

This appendix lists:

- terminal messages and codes that may appear during terminal operation.
- description of self-test numbers.

Types of Terminal Messages

The terminals have different messages to display.

Status Messages

Indicate the terminal is performing an operation that may limit access to the terminal, such as an application download or a communication problem. The message disappears when the terminal completes the operation or when the condition is satisfied.

Reminder Messages

Indicate a minor fault or mistake. Reminder messages appear when an invalid operation is attempted, such as entering an out-of-range value. Pressing any key removes the message.

Warning Messages

Indicate the operation may produce undesirable results. You must respond to warning messages as indicated in the message.

Fault Messages

Indicate the terminal has detected a condition which prevents further operation. The current application will halt. The terminal must be reset (power cycled) to recover from this type of error.

General Terminal Messages

Error Number	Terminal Messages	Type	Meaning	Recommended Action
200-206, 300, 318-321, 328, 329, 331, 346, 347, 355, 356, 358, 367, 404, 411, 416, 417, 421-425, 447-449, 457, 459, 700, 1105, 1111, 1113, 1115, 1207-1211, 2002-2009, 2016, 2018, 2021, 2028 and 2029	A fault has occurred. Error = X	Minor Fault or Terminal Fault	A minor fault was detected that could impact terminal operation or a terminal fault was detected.	Press any key to recover from a minor fault. For terminal faults, contact technical support with the error code.
208	Write to logic controller failed	Comm Status	Controller does not accept data from the terminal. Controller is not connected.	Check connections (on remote I/O units). Verify that controller is in run mode and not busy. Verify that controller data files are not in use by other applications.
303	Aborted.	Reminder/File Transfer Status	The terminal received an abort command during a file transfer.	Try again.
304	File read access error	Reminder	Error reading the source file from a source device.	Try again. If problem continues, contact technical support.
305	File write access error	Reminder	Error writing source file.	Try again. If problem continues, contact technical support.
307	File not supported	Reminder/File Transfer Status	File is incompatible with the terminal's firmware.	Contact technical support to verify compatibility. File must be a .PVA file.
308	Timeout	Reminder / File Transfer Status	The terminal was waiting for the partner device in a file transfer, but the terminal timed out before the data or expected reply was received.	Check cable connections or data corruption with noise on cable. Verify that the computer was not reset. Try again.
309-311	Data corrupted. Verify file and retry.	Reminder/File Transfer Status	The data checksum failed in a file transfer.	Check electrical and cable connections. Try the file transfer again.
312	Unknown device	Reminder / File Transfer Status	Verify the file type entered. Try again.	Destination or source device is invalid for a read or write application transfer.
313	File too large	Reminder / File Transfer Status	Reduce application size. See Appendix A for terminal requirements. If copying to a card, check card space.	File too large to be transferred to the terminal. In a memory card transfer, the card does not have enough space.
314	No Card Inserted	Reminder	Install a memory card and try again.	You tried to transfer data to/from a memory card but there is no card in the card slot.

Error Number	Terminal Messages	Type	Meaning	Recommended Action
315	Unformatted card	Reminder	Memory card is unformatted, contains an unrecognizable format or is corrupt.	Reformat the card or replace it with a new card if corrupt. Try again.
316	Write Protected Card	Reminder / File Transfer Status	A write command to the card failed because the card switch is in the protected mode.	Select write mode by changing the switch on the top edge of the card. Try again.
317	File exists. Cannot overwrite	Reminder/File Transfer Status	See message 342. This message only occurs when the file cannot be renamed.	Change the file name or save to a new memory card.
323	No application on PV terminal	Reminder/File Transfer Status	You tried to load an application on a memory card but there is no application in the terminal.	View the Terminal Info screen to see if an application is loaded in the terminal.
324	Check card status	Reminder/File Transfer Status	Problem formatting the memory card.	Try a new memory card.
325	Unformatted card	Reminder	Memory card is unformatted, contains an unrecognizable format or is corrupt.	Reformat the card or replace it with a new card. Try again.
326	No Card Inserted	Reminder	You tried to transfer data to/from a memory card but there is no card in the card slot.	Install a memory card and try again.
327	No files	Reminder	You tried to transfer a file from the memory card but there are no files on the card.	Use memory card containing application (.PVA) files.
330	Write Protected Card	Reminder / File Transfer Status	A write command to the card failed because the card switch is in protected mode.	Select write mode by changing the switch on the top edge of the card. Try again.
332	No application on PV terminal	Reminder/File Transfer Status	You tried to load an application on a memory card but there is no application in the terminal.	View the Terminal Info screen to see if an application is loaded in the terminal.
333	File in use - Request denied	Reminder	Attempt to format memory card containing a file used by the application. This usually occurs when an application requires a font file on the memory card.	Format the memory card on a computer or a PanelView terminal that does not have an application loaded.
334	Unexpected card removal. Please disconnect card before removal.	Reminder / File Transfer Status	You removed the memory card during normal operation and did not press the Disconnect button on the Memory Card configuration screen.	Press the Disconnect Card button to close the files on the card. When prompted, remove the card from the slot and then re-insert the card. Enter Configuration Mode and press the Run Mode button.
340	Format erases entire card: 0 or F1 Abort 1 or F2 - Continue	Warning	Operator pressed [F4] Erase / Format Card on the Memory Card configuration screen.	Enter appropriate response: 0 or F1 to abort 1 or F2 to continue

Error Number	Terminal Messages	Type	Meaning	Recommended Action
341	Proceed with download? 0 or F1 -Abort 1 or F2 - Continue	Warning	You pressed [F2], Restore From Card on the Memory Card configuration screen.	Enter appropriate response: 0 or F1 to abort 1 or F2 to continue
342	The PVA File exists. 0 or F1 -Abort 1 or F2 - Upload with new PVA filename	Reminder / File Transfer Status	You pressed [F3], Save To Card on the Memory Card configuration screen when the file exists on the card.	Enter appropriate response: 0 or F1 to abort 1 or F2 to upload new PVA file.
361	Value not in range	Reminder	Entered value is outside of valid range.	Enter a value within the valid range.
364	Closing Files...	Status	Terminal is preparing for removal of memory card.	Wait for files to close before removing memory card.
365	Remove card...	Reminder	You must remove the memory card for the terminal to continues operation.	Remove the memory card.
366	Card disconnection will require card removal to continue operation.	Warning	Attempt to disconnect the memory card.	After memory card is disconnected it must be removed from card slot before the terminal will operate.
392	File not supported	Reminder/File Transfer Status	File is incompatible with the terminal type.	In PanelBuilder32, select the Setup tab on the Application Settings dialog and select the correct terminal type.
393	File not supported	Reminder/File Transfer Status	File is incompatible with the communication protocol of the terminal.	In PanelBuilder32, select the Setup tab on the Application Settings dialog and make sure the protocol matches your terminal.
394	File not supported	Reminder/File Transfer Status	File is incompatible with the terminal's firmware.	In PanelBuilder32, click the Catalog & Revisions button on the Setup tab on the Application Settings dialog. Select a firmware version that matches your terminal.
395	File not supported	Reminder/File Transfer Status	File is incompatible with the operator input type (keypad, touch or keypad and touch) of terminal.	In PanelBuilder32, select the Setup tab on the Application Settings dialog. Select the type of operator input that matches your terminal.
396	File not supported	Reminder/File Transfer Status	File is incompatible with the terminal.	Download the file to the terminal again. If problem reoccurs, contact technical support.
415	Retained memory lost. Presets were loaded.	Reminder	The battery backed memory was invalid during startup. The system defaulted to preset values instead of the last states.	No action necessary. Terminal reverts to defaults.

Error Number	Terminal Messages	Type	Meaning	Recommended Action
436	Logic Controller has screen control	Reminder	You tried to change the application screen but it is configured for controller only access.	No action required, controller will change screens as programmed.
634	Read Fail or Write Fail	Status	ControlLogix Tag or address does not exist or is the wrong data type. Designated slot does not contain a ControlLogix Processor.	Check tag address. Check for data type mismatch. Verify ControlLogix slot location.
1109	Font file unavailable, Font error = ****	Minor Fault or Terminal Fault	You downloaded an application to the PanelView without the appropriate memory card (containing the font file) inserted in the card slot of the terminal.	From the Memory Card screen, press the Disconnect button to close the files on the card. Remove the card from the card slot. Locate the card containing the font file or copy the correct font file to a card. Insert the correct memory card in the card slot and enter Run mode.
1110	No valid application	Reminder	You tried to run an application that has not been downloaded to the terminal.	Download application to terminal.
1118	Access denied.	Status	Wrong password entered.	Enter a valid password.
1119	Access denied.	Status	Password not recognized	Enter a valid password.
1120	Security tampering.	Status	PVA file was corrupted - attempt to bypass security was detected	New application file must be downloaded to the terminal.
1121	No operator selected.	Status	There is no currently selected operator, but a password change has been requested	Select the operator requiring the new password.
1122	Password change is not allowed.	Reminder	Password is unchangeable	Password cannot be changed at the current level of security.
1123	Password change is not allowed.	Reminder	Operator cannot change password	Current operator does not have access for password changes.
1124	New password must be entered before it can be verified.	Reminder	New pass words must be entered twice.	Enter the new password again to verify that it was entered correctly.
1125	New and verify passwords differ.	Status	The same password was not entered for verification.	Enter the same password for New and Verify.
1126	Please verify new password.	Reminder	New pass words must be entered twice.	Enter the new password again.
1127	Password changed	Reminder	Password change is effective.	You must use new password for security access.
2005	Application file: Insufficient RAM	Terminal Fault	Application file may be too large.	Try again. If possible, reduce the size of the application.
2007 - 2010	Application file contains errors	Terminal Fault	Application contains incompatible data.	Check application and try again.

Error Number	Terminal Messages	Type	Meaning	Recommended Action
2011	Retained memory lost. Presets were loaded.	Reminder	The battery backed memory was invalid during startup. The system defaulted to preset values instead of the last states.	No action necessary. Terminal reverts to defaults.
2012	Application file: Too many retained memory devices	Terminal Fault	The battery-backed RAM is too full to hold all devices requiring presets.	Reduce the number of control objects. Use global objects.
2014	Hardware configuration is corrupted	Terminal Fault	The terminal hardware configuration is corrupt.	Contact technical support.
2030, 2031	Hardware and firmware do not match	Terminal Fault	A mismatch exists between the terminal firmware and the terminal hardware.	Verify that the series and revision markings on the back of the terminal are compatible with the firmware.

DH-485 Terminal Messages

Error Number	Terminal Messages	Type	Meaning	Recommended Action
612	No active node(s) found on network	Comm Status	Tag or address does not exist or is the wrong data type.	Check tag address. Check for data type mismatch.
613	Required network node(s) not found	Comm Status	Tag or address does not exist or is the wrong data type.	Check tag address. Check for data type mismatch.
615	Duplicate node address	Comm Status	More than one node was assigned the same address.	Verify all device nodes.
616	Data errors on the link	Comm Status	Corrupt data packets were detected on DH-485 network.	Verify controller addressing and baud rate settings. Check for loose or reversed wiring.

ControlNet Terminal Messages

See Terminal Codes for messages below

Error Number	Terminal Messages	Type	Meaning	Recommended Action
634	PanelView offline	Comm Warning	PanelView is offline.	Check connections
634	Write fail.	Comm Warning	PanelView is communicating with the controller. The data table address does not exist.	Check / define data table address in the controller.
634	Write timeout.	Comm Warning	PanelView is not communicating with the logic controller.	Check connections and node configuration in the application.
634	Read fail.	Comm Warning	PanelView is communicating with the controller. The data table address does not exist.	Check/define data table address in the controller.
634	Read timeout.	Comm Warning	PanelView is not communicating with the controller.	Check/define data table address in the controller.
636	Initial write failed.	Reminder	Write to Logic Controller on Startup was configured and on powerup, the PanelView could not write initial values to a node's data table address. or Write to Logic Controller on Startup was not configured and the PanelView was unable to write a controller. Note: The error is only displayed on the first write attempt.	Check/define data table address in the controller. Check communication connections and node configuration in the application.

Remote I/O Terminal Messages

Error Number	Terminal Messages	Type	Meaning	Recommended Action
661	Timeout - No Block Transfer Writes	Comm Status	The PLC is communicating with the terminal, but the PanelView is not receiving BTW requests required by the application.	Check ladder logic for missing BTW instructions (instructions are not enabled) or addressing errors. Check for logic controller errors.
662	Timeout - No Block Transfer Reads	Comm Status	The PLC is communicating with the terminal, but the PanelView is not receiving BTR requests required by the application.	Check ladder logic for missing BTR instructions (instructions are not enabled) or addressing errors. Check for logic controller errors.
663	Timeout - No Block Transfer Requests	Comm Status	The PLC is communicating with the terminal, but the PanelView is not receiving BTR or BTW requests required by the application.	Check ladder logic for missing BTR or BTW instructions (instructions are not enabled) or addressing errors. Check for logic controller errors.
664	PLC in program mode	Comm Status	The PLC is offline (in Program Mode). The COMM Status indicator on the Configuration Mode menu is off.	Place the PLC in run mode to resume communication.
665	No PLC communication	Comm Status	The PLC is not communicating. Possible causes are disconnected cable, no power to PLC, incorrect baud rate or rack settings for PLC configuration. COMM Status indicator is off.	Check for pulled cables and PLC power. Check baud rate settings and rack configurations. Check wiring of connector. Communication resumes when problem is corrected.
666	Invalid Rack Configuration	Comm Status	No communication can occur because of an invalid rack configuration.	Correct the RIO rack configuration.
667	Remote I/O Hardware Failed	Comm Status	During startup, the terminal detected a missing, corrupt or nonfunctional remote I/O card. The terminal will run but not communicate.	Contact technical support and provide specific message.

EtherNet/IP Messages

For a description of EtherNet/IP terminal codes, see [page 263](#).

DH+ Terminal Messages

Error Number	Terminal Messages	Type	Meaning	Recommended Action
675 or 684	Required network node(s) not found	Comm Status	The network is active, but the logic controller(s) are not located at the expected nodes.	Verify that the logic controller(s) required by the application are at the expected node addresses and that the communication parameters are set properly.
676 or 685	File access error	Comm Status	<ol style="list-style-type: none"> 1. The terminal is trying to access one or more controller data files that are unavailable. 2. If the message is flashing, the terminal is trying to read or write data files that are unavailable. 	<ol style="list-style-type: none"> 1. The data files do not exist on the controller. Create the data files. 2. The data file is smaller than what is required. For example, the PanelView uses N7:10 but only N7:0 is defined in the controller.
677 or 686	Unstable DH+ network	Comm Status	Corrupt data packets or intermittent system configuration was detected on DH+ network.	Verify all controller addressing and baud rate settings. Check for loose or reversed wiring.
678 or 687	Duplicate node detected	Comm Status	More than one node was assigned the same address.	Verify all device nodes.
679 or 688	No active Node(s) found on network	Comm Status	No other DH+ devices can be located on the network.	<p>Verify that PanelView terminal and logic controller(s) are correctly connected to the system. Check cable and wiring.</p> <p>If error continues, verify that baud rates on the terminal and controller are the same. Communication resumes when the problem is corrected.</p>
681 or 690	DH+ hardware failed	Comm Status	During startup, the terminal detected a missing, corrupt, or nonfunctional DH+ card. The terminal will run but not communicate.	Contact technical support and provide the specific terminal message.

DF1 Terminal Messages

Error Number	Terminal Messages	Type	Meaning	Recommended Action
675 or 682	Required network node(s) not found	Comm Status	The network is active, but the logic controller(s) are not located at the expected nodes.	Verify that the logic controller(s) required by the application are at the expected node addresses and that the communication parameters are set properly.
676 or 683	File access error	Comm Status	The terminal is trying to access one or more controller data files that are unavailable. If the message is flashing, the terminal is trying to read or write data files that are unavailable.	The data files do not exist on the controller. Create the data files.
679 or 686	Panelview offline	Comm Warning	PanelView is offline.	Check connections
681 or 688	DF1 hardware failed	Comm Status	During startup the terminal detected a missing, corrupt, or nonfunctional DF1+ card. The terminal will run but not communicate.	Contact technical support and provide terminal message.

Terminal Codes

Terminal Codes are displayed on the PanelView terminal during operation or terminal configuration.

DeviceNet Codes

Comm Status codes appear as a banner at the top of an application screen or as a status indicator on the terminal's Configuration screen. Error 634 appears in upper left of banner. Codes less than 12 are minor faults and clear automatically when corrected. Codes above 12 require a terminal reset to clear.

DeviceNet Comm Status Code	Indicates	Recommended Action
1	No connections established. Occurs on power-up until a device connection is established on the network.	Establish a connection over DeviceNet to the PanelView.
2	A connection is in the timed out state. Occurs when I/O polling stops after an I/O poll connection is running.	Check that the network wiring and that the master device (scanner) is operational.
3	An peer tag cannot be obtained. Occurs if the device associated with a peer tag is not responding or the peer tag does not exist at the specified class, instance, and attribute number.	Ensure the data location is correct and that the end device is attached and operational. For write tags, ensure that the appropriate attribute is targeted. If the targeted device is UCMM capable, ensure it has enough explicit message connections to allow the PanelView to take one. If the targeted device is not UCMM capable, ensure that it is owned by a Master device (scanner).
4	A zero length I/O message was received placing the I/O application in idle mode. Occurs when scanner is in program mode.	Error clears when switched back to run. Correct the problem of the Master sending the I/O idle condition.
5	Message Overrun. Message traffic from the PanelView is being generated quicker than it is possible to send the data. Occurs with large I/O sizes when Change-Of-State is being used and state changes are occurring very quickly or if polling too fast.	Slow down I/O polling or the state changes generating Change-of-State I/O messages. Use Cyclic I/O at a fast heartbeat rate rather than Change-of-State. Use the production inhibit capability on the master.
6	Offline Connection Set Identify Received. An Offline Connection Set Point-to-Point Identify Message has been received. Occurs if a Client device on the network capable of executing the Offline Connection Set sends a Point-to-Point Identify message to the terminal while it is in the Offline State. (It failed Duplicate MAC ID Detection on startup).	No action required. The error clears within 500 ms of the last Identify message sent.
7	A Listen Only connection has timed out. It has not received a message in at least four times the expected packet rate value. This occurs if the message associated with the Listen Only tag is not occurring or was not identified correctly.	Check that the Listen Only tags are properly configured. Verify that the associated message is occurring at the expected packet rate. DeviceNet traffic monitor may be helpful.
10	Autobaud in Progress. Occurs on startup while the Autobaud process is executing.	No action required. The error clears within 10 seconds, the maximum time allowed to detect a baud rate.
11	No network power detected. Occurs if network 24V is not present.	Check the wiring. This message will clear automatically when 24V power is restored.
12	Dup MAC Failure. Occurs if the PanelView powers up with the same Node Address present on the network.	Change the node address to an unused address and reset the terminal.
13	Bus-off Interrupt occurred. CAN Chip is held in reset. Caused by noise on network signal lines or an attempt to connect to the network at the wrong baud rate.	Check baud rate and network wiring, including termination resistors. Reset the terminal.

Alert codes appear as a box in the middle of the screen. Error 636 appears in the upper left corner. Operation of the terminal continues. Alert messages can be cleared.

DeviceNet Alert Codes	Indicates	Recommended Action
2	Unsupported DeviceNet Message received. The Network Access Object received a message that is not supported.	Should not occur in normal operation. Clear the message. If problem re-occurs, contact technical support.
3	Initial Writes Failure. The Motherboard failed to send all input data to the daughter card prior to network startup.	Should not occur during normal operation. Clear the message. If problem reoccurs, contact technical support.
4	Invalid Peer Address. Occurs at runtime if the node address of a peer tag is the same as the PanelView.	Clear the message and determine which tag in the application is pointing to the PanelView's node address. Correct the application and or the Indirect Address tag, if used.
7	Change-Of-State Input Overrun. Occurs if PanelView state changes on I/O input data occurs faster than the PanelView can send them to the I/O scanner.	Clear the message. Excessive network traffic could cause this problem if inputs are changing rapidly.
8	An external network process has caused the reset of the network access process. Connections are temporarily lost. Occurs if an external device sends an Identify Object Reset Service to the terminal or if an external device changes the terminal's node address (directly or using the Offline Connection Set).	No action required. Any server connections will need to be re-established.
10	Unsupported DeviceNet message received.	Should not occur during normal operation. Clear the message. If problem reoccurs, contact technical support.
12	Invalid ASA Number (0x00000000 or 0xFFFFFFFF). Occurs if the flash memory is corrupt or an invalid ASA number was programmed.	Clear the message. The message occurs each time the terminal is reset. The terminal operates normally but you should correct the problem. Contact technical support.
14	Get Next Scan Item Failed in peer mode.	Should not occur in normal operation. Clear the message. If problem reoccurs, contact technical support.
15	Peer Input Data not received. Will occur if an input (push button) changes a second time before its previous state was sent on the network. Only for Peer tags.	Clear the message. Excessive network traffic could cause this problem if inputs are changing rapidly. Handle high speed input data over I/O connections if possible.
16	I/O Connection Size does not match size of the data in I/O Assembly Instances (typically Instances 1 and 2). Programmed connection sizes for I/O do not match the amount of data represented by the I/O type tags.	Clear the message and if the problem reoccurs, consult technical support.
19	Get Next Context Request Failure. In Peer Mode scanning, the request to obtain the next tag in current context failed.	Should not occur in normal operation. Clear the message. If problem reoccurs, contact technical support.

DeviceNet Alert Codes	Indicates	Recommended Action
20	Autobaud Failure. The autobaud process failed to detect a valid baud rate within 10 seconds. Occurs if network traffic is nonexistent or intermittent.	Start the terminal when network traffic exists or use a fixed baud rate.
23	Nonvolatile Objects have been reset. Nonvolatile storage of some objects required a full reset on powerup. Certain nonvolatile values will be reset to defaults.	Can occur when the daughtercard firmware in the terminal is upgraded. Clear the message and continue. If problem reoccurs, contact technical support.
38	An external client device on the network has performed a Set Attribute request on the Baud Rate setting. The baud may be different on next terminal reset.	Confirm the Active Baud on the Communication Setup screen of the terminal.

Fault codes appear as a full screen box with Error 635 appears in the upper left corner. Reset the terminal to clear the condition. If the problem reoccurs, note the 2-digit code and contact technical support.

DeviceNet Fault Codes	Indicates	Recommended Action
5	PCCC Message Transaction error during the transfer	Should not occur in normal operation. Clear the message. If problem re-occurs, contact technical support.
6	Stack overflow fault	Should not occur during normal operation. Clear the message. If problem reoccurs, contact technical support.
13	Invalid Screen Context Priority Received	Should not occur during normal operation. Clear the message. If problem reoccurs, contact technical support.
17	Client Object Failed	Should not occur during normal operation. Clear the message. If problem reoccurs, contact technical support.
18	CAN Chip Failed to initialize	Should not occur during normal operation. Clear the message. If problem reoccurs, contact technical support.
33	I/O Assembly Remap Error	Revalidate the application and download. If problem re-occurs, contact technical support.
37	The size of a particular channel exceeds the size limitation set by the daughtercard.	Should not occur during normal operation. Clear the message. If problem reoccurs, contact technical support.
39	The application contains more Listen Only channels that the daughtercard supports.	Reset the terminal. If problem re-occurs, contact technical support.
20xx	Critical Internal DeviceNet firmware fault	Should not occur during normal operation. Clear the message. If problem reoccurs, contact technical support.
9, 11, 21, 22, 24-32, 34-36	Internal faults associated with motherboard/daughtercard communication	Should not occur during normal operation. Clear the message. If problem reoccurs, contact technical support.

General Codes

General Terminal Alert Code	Alert Type	Indicates	Recommended Action
603	Critical fault	File download error	Reset the terminal. If problem occurs again, contact technical support.
9020	Critical fault	An internal fault occurred.	Reset the terminal. If problem occurs again, contact technical support.

ControlNet Codes

These errors appear at the top of the application screen or on the terminal's configuration screen. If you should get an alert number that is not listed, contact technical support.

ControlNet Error Codes	Error Type	Indicates	Recommended Action
1803	Informational	The communication device has completed the request to force the device into the listen-only state.	The PanelView was detected as having a duplicate node address and is in the listen-only mode. Check the node address (MAC ID) of the devices on the network to verify that addresses are not duplicated.
1824	Warning	The PanelView was forced to a listen-only state.	Contact technical support.
1826	Warning	A fixed tag packet was received but there is no place to route the packet. The data packet is discarded and the error message is displayed.	Contact technical support.
1828	Warning	An attempt was made to open an unsupported transport class.	Contact technical support.
1829	Warning	An attempt was made to open a Class 1 transport with application triggering or a Class 3 transport with cyclic triggering.	Contact technical support.
3333	Warning	A connection has timed out.	A file transfer was unexpectedly interrupted. Try to transfer again.

These messages appear on the terminal screen as DC Error=xx. If you get an alert number that is not listed here, contact technical support.

ControlNet Alert Codes	Alert Type	Indicates:	Recommended Action
9000	Critical fault	Interface startup failed.	Contact technical support.
9003	Critical fault	CIP S/N is not valid.	Contact technical support.
9004	Critical fault	Out of buffers.	Contact technical support.
9010	Critical fault	Invalid target node, target node is the same as the PanelView, or larger than the UMAX.	Check node address of all devices on the network including the PanelView terminal.
9012	Communication Warning	ControlNet object received a reset request.	Contact technical support.
9014	Critical fault	A fatal CPU fault occurred.	Contact technical support.
9015	Critical fault	A ControlNet hardware fault occurred.	Contact technical support.
9016	Critical fault	RAM verification failed at startup.	Contact technical support.
9017	Critical fault	CRC verification failed at startup.	Contact technical support.
9018	Critical fault	A critical internal error occurred.	Contact technical support.
9019	Critical fault	An internal fault occurred.	Reset terminal, if problem occurs again, contact technical support.
9020	Critical fault	An internal fault occurred.	Reset terminal. If problem occurs again, reload application. If problem persists, contact technical support.

EtherNet/IP Codes

These messages appear on the terminal screen as DC Error=xx. If you get an alert number that is not listed here, contact technical support.

Error Number	Terminal Messages	Type	Meaning	Recommended Action
xx,xx,xx Number depends on hardware fault detected.	Communication Interface Fault	Critical Fault	A hardware problem was detected during power-up. If you ignore message and display the EtherNet/IP Communication Screen, the Comm Status displays "Comms hardware fault:" without an error number. The FW revision, serial number and EtherNet/IP address fields are displayed.	Contact technical support to have unit repaired.
770	Buffer overflow	Comm Status	Internal error occurred.	Contact technical support.
771	Buffer underflow	Comm Status	Internal error occurred.	Contact technical support.
1799	Heap partition empty	Comm Status	Internal error occurred.	Contact technical support.
16387	Comms not started yet...	Comm Status	The PanelView has not connected to the network.	Check IP configuration (on the Communication Setup screen) and wait for PanelView to connect to the network.
16388	CIP S/N is not valid	Critical fault.	DC incorrectly configured.	Contact technical support.
16389	Out of buffers	Critical fault.	No buffers are available for read or write operations.	Contact technical support.
16390	An initial write failed	Comm Warning	Write to Logic Controller on Startup was configured and on powerup, the PanelView could not write initial values to a node's data table address. or Write to Logic Controller on Startup was not configured and the PanelView was unable to write a controller. Note: The error is only displayed on the first write attempt.	Check/define data table address in the controller. Check communication connections and node configuration in the application.
16391	PV write failed	Comm Warning	PanelView is communicating with the controller. The data table address does not exist.	Check/define data table address in the controller.
16392	PV write timeout	Comm Warning	PanelView is not communicating with the logic controller.	Check connections and node configuration in the application.
16393	PV read fail	Comm Warning	PanelView is communicating with the controller. The data table address does not exist.	Check/define data table address in the controller.
16394	PV read timeout	Comm Warning	PanelView is not communicating with the controller.	Check/define data table address in the controller.
16397	CN object received a reset request	Comm Warning	An Ethernet object received a reset request from a device on the network.	The PanelView does not support network resets.

Error Number	Terminal Messages	Type	Meaning	Recommended Action
16398	The Connection Originator is indicating it is in Program Mode	Comm Warning	The logic controller is offline (in Program Mode). The COMM Status indicator on the Configuration Mode menu is off.	Place the logic controller in run mode to resume communication.
16399	A fatal CPU fault occurred	Critical Fault	A fatal CPU fault occurred.	Contact technical support.
16401	The RAM check failed	Critical Fault	RAM verification failed at startup.	Contact technical support.
16402	The CRC check of the firmware failed	Critical Fault	CRC verification failed at startup.	Contact technical support.
16403	OS startup failed	Critical Fault	Operating system failed to start.	Contact technical support.
16404	PV Client Task Fault	Critical Fault	Internal error has occurred.	Contact technical support.
16405	Invalid preset information received from motherboard.	Critical Fault	Internal error has occurred.	Contact technical support.
16406, 16407	Connection with Addr or scan rate invalid or no connection being attempted.	Critical Fault	Internal error has occurred.	Contact technical support.
16408	No buffers available for read operation	Critical Fault	Internal error has occurred.	Contact technical support.
16409	DC couldn't send out the write request in time.	Critical Fault	Too many write operations are occurring.	Contact technical support.
16410	Too many clients attempted to connect to server	Critical Fault	Internal error has occurred.	Contact technical support.
16411	XS-WD creation error	Critical Fault	Internal error has occurred.	Contact technical support.
16412	XS-WD start error	Critical Fault	Internal error has occurred.	Contact technical support.
16413	ENet addr is not valid	Communication Warning	The EtherNet address for a device on the EtherNet/IP network is invalid.	Contact technical support.
16414	Duplicate IP address detected	Critical Fault	The PanelView has the same IP address as another device on the EtherNet/IP network.	Change the IP address of the PanelView (on the Communication Setup screen) so that is unique on the network.
16415	Unknown error detected	Communication Warning	An operating system message has occurred.	Contact technical support.
16416	No network link	Critical Fault	Communication has not been established with network.	Check Ethernet cable.

Error Number	Terminal Messages	Type	Meaning	Recommended Action
16417	DHCP/BootP Enable failed	Communication Warning	The DHCP/BootP Enable server failed to allocate an IP address, subnet mask and gateway address to the PanelView terminal	Check DHCP/BootP Enable server on your network.
16418	Invalid IP Address or Subnet Mask	Communication Warning	The IP address or the subnet mask of the PanelView terminal is not valid. Important: The Gateway Address cannot be entered at the terminal; you must configure this address in the Communication Setup dialog of PanelBuilder32.	Enter a valid IP address and/or the subnet mask of the PanelView terminal on the Communication Setup screen. This error occurs if the downloaded application has DHCP/BootP enabled and it is then disabled at the terminal. On a restart, the terminal will not have the necessary information (IP Address, Subnet Mask, Gateway Address) to connect to the network.
16420	Invalid Gateway Address	Communication Warning	The Gateway Address is not valid.	Change the Gateway Address in the PanelBuilder32 software.

Remote I/O Communication Loss

When communication fails on a remote I/O network:

- Object states are maintained and the message No PLC Communication is displayed on the screen.
- If Block Transfers are defined for the application, but no BTR or BTW instructions are received, another message appears when the Block Transfer Timeout occurs.

These messages continue to display until communication is established. If a write operation is attempted to the logic program controlling the PanelView objects, the terminal will display the message Error: Write to Logic Controller failed.

If a PanelView object is activated during a communication loss, the object retains its new state and sends this state value to the controller when communication is established.

Self-test Numbers

The self-test numbers appear on the screen during powerup.

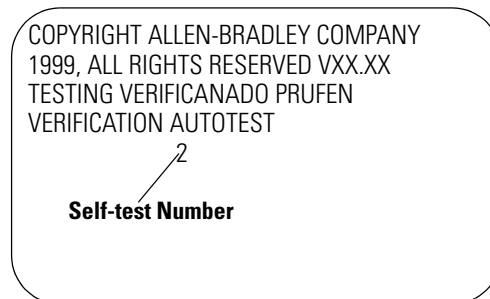

Test Number	Indicates
1	STATIC RAM test
2	Terminal searching for a file to download.
10	Erase boot flash area.
11	Copy boot code
12	Boot code copy successful
13	Boot code copy failed. Check for error after boot code is copied to the onboard flash EPROM.
20	Erase firmware from flash EPROM
21	Copy firmware to firmware flash memory
22	Firmware copy successful
23	Firmware copy failed
24	Performed CRC base firmware check

Test Number	Indicates
25	Firmware not compatible with boot code
26	Firmware not compatible with hardware
30	Watchdog test
31	Stuck key test
32	Real time clock test
33	LCD RAM failed
34	Performed CRC extended firmware check

TIP You may not see all of these test numbers during a powerup.

If a test fails, the terminal displays:

ERROR! FEHLER! ERREUR! ERRORE!

The following test numbers appear only if a problem occurs.

Test Number	Indicates
40	No executable code to run after boot
50	Wrong memory card format
60	CPU could not execute code

The table below shows fault conditions that may occur during powerup.

Fault Indicator	Indicates
Solid Red	Static RAM Test failed. Contact technical support.
Blinking Red (6 times per second)	Checksum test on boot code failed. Contact technical support.
Blinking Red (5 seconds on/5 seconds off)	Boot code is incorrect for terminal type (touch screen or keypad). Contact technical support.

European Union Directive Compliance

If the PanelView Operator Terminals are installed within the European Union or EEA regions and have the CE mark, the following regulations apply.

EMC and Low Voltage Directives

These apparatuses are tested to meet Council Directive 89/336/EEC Electromagnetic Compatibility (EMC), and amending directives 92/31/EEC, 93/68/EEC; 73/23/EEC Low Voltage Directive, and amending directive 93/68/EEC using the following standards, in whole or in part:

	300 Micro	300	550	600	900M	900C	1000G	1000C	1400
Emissions (Class A: Industrial) EN50081-2:1993	x	x	x	x	x	x	x	x	x
Immunity (Industrial) EN61000-6-2:1999	x	x ⁽¹⁾	x ⁽¹⁾	x ⁽¹⁾	x ⁽¹⁾	x ⁽¹⁾	x ⁽¹⁾	x ⁽¹⁾	x ⁽¹⁾
Immunity (Industrial) EN50082-2:1995 ⁽²⁾		x	x	x	x	x	x	x	x
Programmable Controllers Equipment Requirements and Tests) EN61131 2:1995		x	x	x	x	x	x	x	x
Low Voltage Directive (Safety Sections of EN61131-2)			x	x	x	x	x	x	x

⁽¹⁾ Meets standard as of April 2002.

⁽²⁾ This standard applies to products manufactured prior to April 2002.

Intended Use of Product

According to these Standards, the factor which determines, for EMC purposes, whether a product is deemed to be Industrial rather than Residential, commercial or light industrial, is given in clause 1 of EN50081-2 as follows:

Apparatus covered by this standard is not intended for connection to a public mains network supplied from a high- or medium-voltage transformer dedicated for the supply of an installation feeding a manufacturing or similar plant.

When installed in Europe, any other application is in contravention of European Union Directives, and a breach of these laws.

The PanelView 900 color, the 1000 grayscale and the 1400 terminals are certified for direct connection to a low-voltage public mains supply or to a dedicated source, which is intended to interface to a low-voltage public mains supply.

Wiring Recommendations

To reduce electrical noise, connect the PanelView terminal to its own branch circuit. The input power source should be protected by a fuse or circuit breaker rated no more than 15 amps. Route incoming power to the PanelView terminal by a separate path from the communication cable.

Where power and communication lines must cross, they should cross at right angles. Communication lines can be installed in the same conduit as low-level dc I/O lines (less than 10 Volts).

Declarations of Conformity

Declarations of Conformity are available for each of the PanelView terminals at the website <http://www.ab.com/support> under Product Certification.

Battery Replacement and Disposal

The terminal contains a lithium battery, which is intended to be replaced during the life of the product.



At the end of its life, the used battery should be collected separately from any unsorted municipal waste and recycled.

The Micro 300 terminal contains a lithium battery, which is permanently connected and should only be removed or replaced by trained professionals.

Please refer to the terminal installation instructions for procedures to remove the terminal battery.

PanelView Terminal	Publication
PanelView 300 Micro	2711-IN008
PanelView 300 Keypad	2711-IN027
PanelView 550	2711-IN009
PanelView 550/600 Touch	2711-IN034
PanelView 600	2711-IN010
PanelView 1000	2711-IN036

adapter

ControlNet device that responds to scanner messages (also called slave device).

address

1) A character string that uniquely identifies a memory location. 2) A character string that uniquely identifies the physical location of an input or output circuit.

application

In the context of PanelBuilder32 software, an application is a logical arrangement of screens that replace the functions of a control panel and consist of push buttons, data entry objects, control lists, and indicators. The application runs in a PanelView terminal.

application file

File containing configuration information for a PanelView terminal. Files exist in either a PanelView (.PVA) or a PanelBuilder32 (.PBA) format. Files transferred to a terminal are in a .PVA format. Files within PanelBuilder32 software are in a .PBA format.

ATA card

Advanced Technology Attachment (ATA), Intelligent Drive Electronics (IDE), PC cards (formerly PCMCIA) combine the drive controller and memory storage device. ATA cards can be accessed with standard Copy or Delete commands on a computer. The card looks like a hard drive. You can use the card on a variety of computers without any special setup.

baud

A unit of signaling speed equal to the number of discrete conditions or signal events per second. Where one bit is encoded on each signalling event, the number of baud is the same as the number of bit/s.

boot revision

Revision number of the terminal boot code.

bridge

Device that lets network data pass from one link to another link.

controller

A unit, such as a programmable controller or relay panel, that controls machine or process elements.

cursor keys

Up, down, left, right arrows on the terminal keypad. These keys are used to move a selection cursor or the active object indicator bar.

DF1

Allen-Bradley communication protocol based on an ANSI X3.28-1976 specification.

download

See upload/download.

DH-485 link

Data Highway 485 link. An Allen-Bradley token-passing carrier-band link for a local area network.

DH+™ link

Data Highway Plus link. An Allen-Bradley token-passing baseband link for a local area network.

DHCP

Dynamic Host Configuration Protocol (DHCP) software allows for dynamic allocation of addressing information for new attached devices on a TCP/IP network.

Domain Name

Character string mapping the local domain to the IP address of the DNS server. See DNS Server.

DNS Server

The domain name server (DNS) converts more convenient host names into IP addresses. The DNS server is identified by a 32-bit IP address.

EMI

Electromagnetic interference. Any electromagnetic disturbance that interrupts, obstructs, or otherwise impairs the performance of electronic equipment.

EPROM

Erasable programmable read-only memory. A PROM that can be erased, usually with ultraviolet light, then re-programmed with electrical signals. As with all PROMs, it is nonvolatile random-access memory.

EEPROM (flash)

Electrically-erasable programmable read-only memory. A type of PROM that can be erased and re-programmed by electrical signals. As with all PROMs, it is nonvolatile random-access memory. Used by the PanelView terminals to store applications.

firmware

Logic stored in read-only memory.

function keys

Set of keys (labeled F1-F10, F1-F16 or F1-21) on the PanelView terminals used to initiate functions. The function keys are user-defined and may have custom labels.

gateway address

A unique 32-bit address of the gateway connecting two individual IP networks into a system of networks. When a node needs to communicate with a node on another network, the gateway transfers the data between the two networks. The IP address is formatted as four sets of decimal numbers (0..255) with periods between them (130.200.25.30).

interscan delay

Determines the amount of time the PanelView terminal waits before re-reading the current screen data from the logic controller.

IP address

A unique 32-bit address of a node on the EtherNet/IP network.

keeper

The network controller of a ControlNet network.

keypad

Set of 14 keys (numeric 0-9, decimal point, backspace, minus, and enter) to the right of the display on keypad terminals. These keys are used to enter data.

LED

Light-emitting diode. See status indicator.

Memory Card

A storage medium that can store a PanelView application and/or a font file.

MicroLogix

An Allen-Bradley programmable controller.

NEMA standards

Consensus standards in the United States for electrical equipment approved by the members of the National Electrical Manufacturers Association (NEMA).

network

Collection of connected nodes including the connection paths, repeaters, and bridges.

network access point (NAP)

Port providing temporary access to a ControlNet network through the RJ-45 connector.

network update time (NUT)

The ControlNet network update time established for the communication link.

node

The connection point at which medium access is provided.

PanelBuilder32 software

A Windows program used to develop applications that run in PanelView terminals.

PanelView terminal

An Allen-Bradley keypad or touch screen terminal providing the operator interface to the logic controller when an application is executing.

PC

1) Personal Computer. 2) Programmable Controller. 3) Printed Circuit.

PCCC

Acronym for Programmable Controller Communication Commands.

PGM (Program)

PGM setting means the baud rate is set via an explicit message request over the network by another device (typically a configuration tool, such as a PC or DeviceView). This baud rate setting is retained by the daughtercard when the power is cycled on the PanelView terminal.

PLC controller

1) An Allen-Bradley programmable controller with a name that has the prefix PLC. See programmable controller.

preset value

A value loaded into a controller data table when an application is first started.

programmable controller

A solid-state control system that has a user-programmable memory for storage of instructions to implement specific functions such as I/O control, logic, timing, counting, report generation, communication, arithmetic, and data file manipulation. A controller consists of a central processor, input/output interface, and memory. A controller is designed as an industrial control system.

real time clock

Internal clock that provides time, day, month and year.

remote I/O

1) I/O connected to a processor across a serial link. With a serial link, remote I/O can be located long distances from the processor.

remote I/O link

A serial link for carrying I/O data between a PLC or SLC processor/scanner and remote I/O adapters.

repeater

Two-port component that receives and transmits all data from one segment to another.

restore

To load an application from a memory (PC) card.

RS-232

An EIA standard that specifies electrical, mechanical, and functional characteristics for serial binary communication circuits in a point-to-point link.

RS-485

An EIA standard that specifies electrical characteristics of balanced-voltage digital interface circuits in a multi-point link.

scheduled messages

Messages that occur at a regular specified interval. They are assigned a particular portion of the network update time (NUT) and are always transmitted at that time.

safety extra-low voltage (SELV)

A voltage that, under all operating conditions does not exceed 42.4 V peak or dc between conductors, or between any conductor and earth, in a circuit that is isolated from the main power supply by means of a safety isolating transformer or an equivalent means. National regulations have to be considered for a correct isolation voltage rating.

scratchpad

A window that appears in the center of the terminal display that allows data entry by using the terminal or screen keypad.

screen

1) the viewing surface on which data is displayed. 2) The visual image on a screen.

segment

Trunk-cable sections connected through taps with terminators at each end and no repeaters.

SLC

An Allen-Bradley programmable controller with a name that has the prefix SLC.

SMAX

Highest ControlNet node address that can communicate during the scheduled portion of the network update interval.

status indicator

An LED that indicates Comm or Fault status.

subnet mask

A 32-bit value forming the PanelView terminal's subnet mask. This parameter interprets IP addresses when the EtherNet/IP network is divided into multiple networks. The IP address is formatted as four sets of decimal numbers (0...255) with periods between them (130.200.25.30).

tap

Hardware component that connects devices to the ControlNet trunk cable.

touch cell

1 of 128 or 384 rectangular areas on the terminal display that can sense when touched.

touch screen

The display window of the terminal that responds when touched.

trunk cable

Bus or central part of a cable system.

unscheduled messages

Messages that are sent on an as needed basis. Unscheduled messages are sent during the unscheduled portion of the network update interval.

UMAX

Highest ControlNet node address that can communicate during the unscheduled portion of the network update interval.

upload/download

Commonly referred to the reading/writing across a link relatively large blocks of data from one device to another. Whether it is considered an upload or download may depend upon whether it is a read or write and upon which device initiates the transaction. When data is transferred to a programming device, it is considered an upload. When data is transferred from a programming device, it is considered a download.

A**ac power**

- connecting 61
- electrical ratings 61

accessories

- antiglare overlay 53
- backlight lamp 56
- cables 53-55
- file transfer utility 54
- function key legend kits 52
- memory card retainer 52
- memory cards 52
- mounting clips 57
- mounting studs 57
- real time clock 56
- wallmount power supply 54

alarms

- content 131
- description 51

antiglare overlay 53**application files**

- running 48
- settings 71

ASCII entry controls

- description 121
- entering data 121-124
- scratchpad in other languages 125
- scratchpads 121-124

audience 15**B****backlight lamps 56**

- replacing 232

bar graphs 128**boot code revision 89****C****cables**

- application file upload/download direct 184
- DeviceNet 213
- DH+ 191
- DH-485 53, 193
- Ethernet 216
- remote I/O 55, 187
- RS-232 55
- runtime communication cables to
 - network interface module 183
- runtime communication cables to
 - processor 178

card, memory 52, 105**certifications 248****cleaning, display window 231****Comm status indicator 73, 229****communication ports 18-25****configuration mode menu 50**

- accessing 72
- operations list 72

configuration screens

- DF1 84
- DH+ 77
- DH-485 75
- EtherNet/IP 86
- language selection 73
- memory card transfers 74
- preset operations 88
- printer setup 102
- remote I/O 68, 78
- screen setup 90
- terminal information 89
- time and date 100

control lists 115

- activating 115
- active item 115
- active list 115
- cursor 116
- list keys 117
- piloted 117
- selecting an item 118
- vertical indicator bar 116

ControlNet communication

- active node 80
- available terminals 19-25
- channel status 81
- communication status 80
- compatible controllers 208
- connecting a printer 223
- ControlNet ports 208
- ControlNet protocol 208
- firmware revision 80
- related information 207
- serial number 80
- typical network 209

D**data entry**

- ASCII entry cursor point 121
- ASCII entry keypad enable button 121
- ASCII scratchpad 121
- keypad enable button 118
- numeric entry cursor point 118
- numeric scratchpad 119

date and time setup 100

dc power

- connecting 63-??
- electrical ratings 63

declarations of conformity 270**DeviceNet communication**

- active baud rate 83
- active node 82
- available terminals 18-25
- connecting a computer 223
- connecting a printer 223
- DeviceNet ports 212
- input size 84
- making connections 213
- output size 84
- status indicators 84

DF1 communication

- available terminals 18-25
- baud rate 85
- Comm status indicator 86
- compatible controllers 203
- configuration screen 84
- connecting to a CompactLogix 205
- connecting to a DeviceNet or EtherNet/IP network 206
- connecting to a FlexLogix 205
- connecting to a MicroLogix 1000 204
- connecting to an SLC or PLC 205
- DF1 port pinouts 204
- DF1 ports 202
- error detection (CRC or BCC) 85
- handshaking 85
- null modem cable 207
- serial communication parameters 85
- using a modem 206

DH+ communication

- available terminals 18-25
- cable 191
- configuration screen 77, 84
- connecting a computer 223
- connecting a printer 223
- DH+ communication port 189
- making DH+ connections 191
- RS-232 port 190
- status indicators 77
- typical system configuration 190

DH-485 communication

- available terminals 17
- cables 193
- configuration screen 76
- connecting a computer 196
- connecting a printer 223
- DH-485 communication port 192
- DH-485 programming connector 192

DH-485 communications

- hand-held terminal connection 198
- LED indicators 76
- link coupler 194
- MicroLogix connection 195
- network connection 194
- ports 192
- power supply 196
- RS-232 port 192
- SLC connection 193
- SLC connection using AIC+ 195

display

- adjusting settings 90-99
- cleaning window 231
- color 18
- grayscale 18
- monochrome 18

E**EtherNet/IP communication**

- available terminals 19-25
- cable 216
- compatible controllers 215
- configuration screen 86
- DHCP/BootP Enable 87
- interscan delay 87
- IP address 87
- network configuration 217
- RJ45 Ethernet connector 216
- terminal ports 215

European Union Directive Compliance

15, 269

F**fault messages** 249**fault status indicator** 73, 229**file transfer utility** 54**firmware revision** 89**font files** 90, 111**function key legend kits** 49, 52**I****indicators**

- bar graphs 128
- list indicators 128
- multistate indicators 128

initial screen 67**installation of terminals** 15, 16

installing the PanelView 1000

- clearances 165
- cutout dimensions 166
- enclosures 162
- mounting dimensions 164
- panel installation 167
- required tools 162

installing the PanelView 1400

- clip mounting 173
- cutout dimensions 172
- enclosures 169
- mounting dimensions 170
- required tools 169
- stud mounting 175

installing the PanelView 300

- clearances 142
- cutout dimensions 141
- enclosures 140
- mounting dimensions 140
- panel installation 143
- required tools 140

installing the PanelView 300 Micro

- clearances 135
- cutout dimensions 135
- enclosures 134
- hazardous locations 133
- mounting dimensions 134
- panel installation 136
- required tools 134

installing the PanelView 550

- clearances 148
- cutout dimensions 149
- enclosures 145
- hazardous locations 145
- mounting dimensions 147
- panel installation 150
- required tools 147

installing the PanelView 600

- clearances 157
- cutout dimensions 156
- enclosures 154
- hazardous locations 153
- mounting dimensions 155
- panel installation 158
- required tools 154

installing the PanelView 900

- clearances 165
- cutout dimensions 166
- enclosures 162
- mounting dimensions 163
- panel installation 167
- required tools 162

K**keypad enable button** 118**keypad terminals**

- available options 17
- operation 49

L**language**

- selection 73
- types 73

link coupler 54, 194, 195**list indicators** 128**list keys**

- control lists 117
- screen selector lists 127

M**memory card** 52

- installation 106
- loading application from card 108
- loading application onto card 110
- removing 74, 112
- storing font files 111
- types 105
- using retainer 106
- write protection 227, 251

message displays 129**messages**

- fault 249
- general 250
- reminder 249
- remote I/O 267
- status 249
- warning 249

mounting clips 57**mounting studs** 57**multistate indicators** 128**N****numeric data displays** 129**numeric entry controls**

- cursor point 118
- description 118
- entering data 119
- keypad enable button 118
- scratchpad 119

P**PanelView 1000**

- connecting AC power 61
- connecting dc power 63
- features 40, 163, 169
- installation 161
- resetting 66
- screen adjustments 94
- screen saver 94
- specifications 244

PanelView 1400

- aligning the touch grid 100
- connecting AC power 61
- features 44
- installation 169
- resetting 66
- screen adjustments 98
- specifications 245

PanelView 300

- connecting dc power 63
- features 26, 27
- resetting 66
- specifications 233

PanelView 300 Micro

- connecting to AIC+ 220
- connecting to DNI 220
- connecting to MicroLogix 218
- connecting to personal computer 221
- connecting to SLC or ControlLogix 219
- features 18, 26
- installation 133
- resetting 66
- screen adjustments 90
- specifications 233

PanelView 550

- connecting AC power 61
- connecting dc power 63
- features 29
- installation 145
- resetting 66
- screen adjustments 90
- specifications 236
- turning backlight on and off 91, 93, 94, 95, 97, 98

PanelView 600

- connecting AC power 61
- connecting dc power 63
- features 34
- installation 153
- resetting 66
- screen adjustments 94
- screen saver 94
- specifications 238

PanelView 900

- connecting AC power 61, 63
- features 40, 163, 169
- installation 161
- resetting 66
- screen adjustments 94, 95
- screen saver 94
- specifications 240

PanelView terminals

- operation 49
- types 17

pass-through 69, 78**personal computer interface converter**

53

- connecting earth ground 196

PIC converter 196**power connection**

- ac power 61
- dc power 63-??

power supply 54, 196**powerup sequence** 67

- DH-485 terminals 67
- remote I/O terminals 68
- RS-232 terminals 67

preset operations

- initial values 88
- last state values 88
- powerup screen 88
- preset values 88
- restart and load values 88

printer port setup

- configuring 102
- handshaking 102
- port pinout 223

printing 51, 130**push buttons**

- hold time 114
- operation 114

R**real time clock** 56

- replacement 232

reminder messages 249**remote I/O communication**

- available terminals 19-25
- baud rate 69
- block transfer timeout 69
- cable 187
- configuration screen 78
- connecting a computer 223
- connecting a printer 223

- connecting to a remote I/O scanner 187
- last chassis 69, 79
- out-of-box application 68
- pass-through 69, 78
- rack number 69, 78
- rack size 69, 78
- remote I/O port 185
- RS-232 port 185
- starting module group 69
- supported controllers 186

resetting

- PanelView 1000 66
- PanelView 1400 66
- PanelView 300 66
- PanelView 300 Micro 66
- PanelView 550 66
- PanelView 600 66
- PanelView 900 66

RS-232 (DH-485) communication

- available terminals 19-25
- CompactLogix connection 200
- connecting a computer 223
- connecting a printer 223
- connecting to DH+ link 202
- RS-232 port 199
- SLC connection 200

RS-232 serial port

- cables 223
- configuring 102
- connecting a computer 223
- connecting a printer 223
- port pinout 223

S

- scale, bar graph** 128

scratchpad

- ASCII entry 121-124

screen saver 94**screen selectors**

- activating a list 126
- description 126
- list keys 127
- selecting an item 126
- vertical indicator bar 127

self-test numbers 67, 267**specifications**

- PanelView 1000 244

- PanelView 1400 245
- PanelView 300 234
- PanelView 300 Micro 233
- PanelView 550 236
- PanelView 600 238
- PanelView 900 240

status indicator

- Comm 73, 229
- fault 73, 229

status messages 249**T****terminal codes**

- ControlLogix 262
- ControlNet 262
- DeviceNet 258
- Ethernet 263

terminal information

- boot revision 89
- current application 89
- firmware revision 89
- font file in use 90
- hardware configuration 89

terminal messages

- ControlNet 255
- DF1 258
- DH+ 257
- DH-585 254
- remote I/O 256

terminals

- installation 15, 16
- types 17

terminology 15**time and date setup** 100**touch screen terminals**

- available options 19-25

troubleshooting

- correcting problems 225
- problems 225

W

- wallmount power supply** 54, 196

warning messages 249**write protection**

- memory card 227, 251

How Are We Doing?

Your comments on our technical publications will help us serve you better in the future. Thank you for taking the time to provide us feedback.

You can complete this form and mail (or fax) it back to us or email us at RADocumentComments@ra.rockwell.com.

Pub. Title/Type PanelView Standard Operator Terminals

Cat. No. PV300 Micro, PV300, PV550, PV600, PV900, PV1000, PV1400 Pub. No. 2711-UM014G-EN-P Pub. Date September 2008 Part No. PN 14527

Please complete the sections below. Where applicable, rank the feature (1=needs improvement, 2=satisfactory, and 3=outstanding).

Overall Usefulness	1	2	3	How can we make this publication more useful for you?									
Completeness (all necessary information is provided)	1	2	3	Can we add more information to help you?									
				<table style="width: 100%; border: none;"> <tr> <td style="width: 33%;">procedure/step</td> <td style="width: 33%;">illustration</td> <td style="width: 33%;">feature</td> </tr> <tr> <td>example</td> <td>guideline</td> <td>other</td> </tr> <tr> <td>explanation</td> <td>definition</td> <td></td> </tr> </table>	procedure/step	illustration	feature	example	guideline	other	explanation	definition	
procedure/step	illustration	feature											
example	guideline	other											
explanation	definition												
Technical Accuracy (all provided information is correct)	1	2	3	Can we be more accurate?									
				<table style="width: 100%; border: none;"> <tr> <td style="width: 50%;">text</td> <td style="width: 50%;">illustration</td> </tr> </table>	text	illustration							
text	illustration												
Clarity (all provided information is easy to understand)	1	2	3	How can we make things clearer?									
Other Comments				You can add additional comments on the back of this form.									

Your Name _____
 Your Title/Function _____
 Location/Phone _____

Would you like us to contact you regarding your comments?
 No, there is no need to contact me
 Yes, please call me
 Yes, please email me at _____
 Yes, please contact me via _____

Return this form to: Rockwell Automation Technical Communications, 1 Allen-Bradley Dr., Mayfield Hts., OH 44124-9705

PLEASE FASTEN HERE (DO NOT STAPLE)

Other Comments

Lined area for writing comments.

PLEASE FOLD HERE

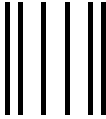

NO POSTAGE
NECESSARY
IF MAILED
IN THE
UNITED STATES

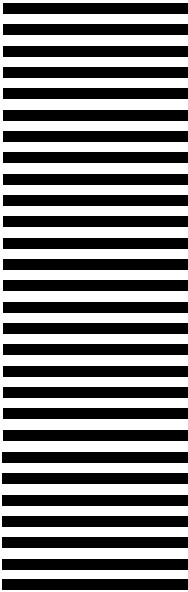

BUSINESS REPLY MAIL
FIRST-CLASS MAIL PERMIT NO. 18235 CLEVELAND OH

POSTAGE WILL BE PAID BY THE ADDRESSEE

Rockwell Automation

1 ALLEN-BRADLEY DR
MAYFIELD HEIGHTS OH 44124-9705

Rockwell Automation Support

Rockwell Automation provides technical information on the Web to assist you in using its products. At <http://support.rockwellautomation.com>, you can find technical manuals, a knowledge base of FAQs, technical and application notes, sample code and links to software service packs, and a MySupport feature that you can customize to make the best use of these tools.

For an additional level of technical phone support for installation, configuration, and troubleshooting, we offer TechConnect support programs. For more information, contact your local distributor or Rockwell Automation representative, or visit <http://support.rockwellautomation.com>.

Installation Assistance

If you experience a problem within the first 24 hours of installation, please review the information that's contained in this manual. You can also contact a special Customer Support number for initial help in getting your product up and running.

United States	1.440.646.3434 Monday – Friday, 8am – 5pm EST
Outside United States	Please contact your local Rockwell Automation representative for any technical support issues.

New Product Satisfaction Return

Rockwell Automation tests all of its products to ensure that they are fully operational when shipped from the manufacturing facility. However, if your product is not functioning and needs to be returned, follow these procedures.

United States	Contact your distributor. You must provide a Customer Support case number (call the phone number above to obtain one) to your distributor in order to complete the return process.
Outside United States	Please contact your local Rockwell Automation representative for the return procedure.

www.rockwellautomation.com

Power, Control and Information Solutions Headquarters

Americas: Rockwell Automation, 1201 South Second Street, Milwaukee, WI 53204-2496 USA, Tel: (1) 414.382.2000, Fax: (1) 414.382.4444

Europe/Middle East/Africa: Rockwell Automation, Vorstlaan/Boulevard du Souverain 36, 1170 Brussels, Belgium, Tel: (32) 2 663 0600, Fax: (32) 2 663 0640

Asia Pacific: Rockwell Automation, Level 14, Core F, Cyberport 3, 100 Cyberport Road, Hong Kong, Tel: (852) 2887 4788, Fax: (852) 2508 1846

Publication 2711-UM014G-EN-P - September 2008

Supersedes Publication 2711-UM014F-EN-P - August 2007

PN 14572

Copyright © 2008 Rockwell Automation, Inc. All rights reserved. Printed in the U.S.A.