

## Data Sheet | Item Number: 828-334

Feedthrough terminal block; lever; Plate thickness: 3 mm; 16 mm<sup>2</sup>; Pin spacing 11.5 mm; 4-pole; CAGE CLAMP®; 16,00 mm<sup>2</sup>; gray

<https://www.wago.com/828-334>

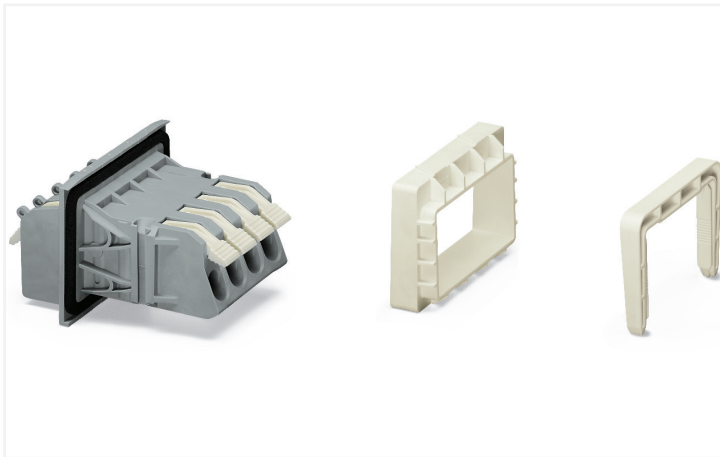

Color: ■ gray

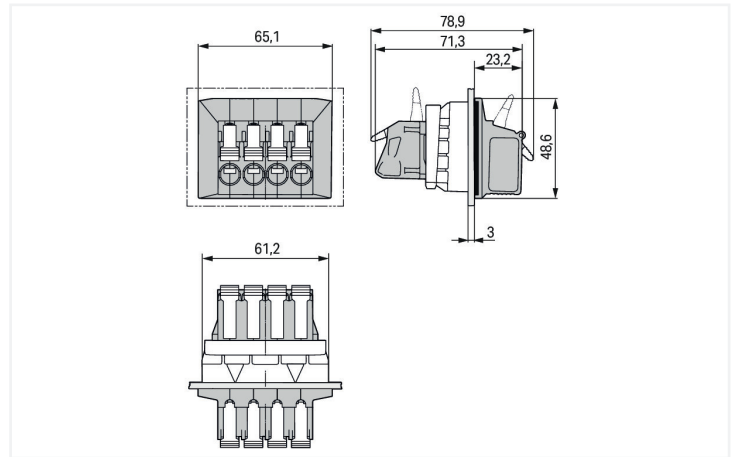

Dimensions in mm

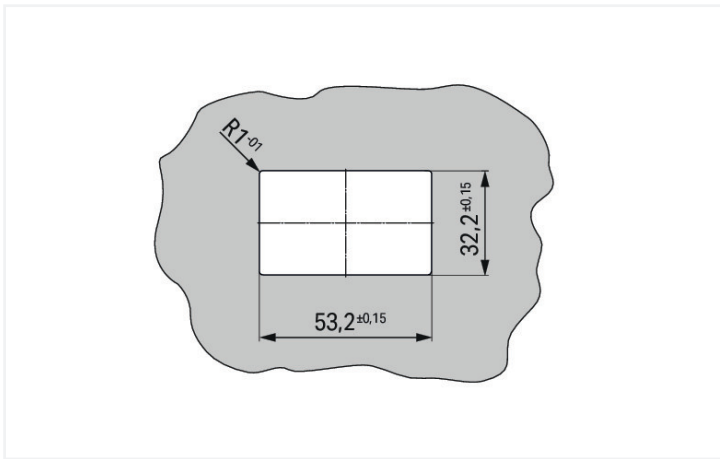

Dimensions in mm

### Feedthrough terminal block, 828 Series, lever

Enjoy effortless electrical installations with feedthrough terminal block (item number 828-334). Conductors can only be connected to feedthrough terminal block if their strip length is between 12 and 13 mm. Featuring two conductor terminals along with CAGE CLAMP®, this connector outperforms the competition. Our proven universal connection known as CAGE CLAMP® is the industry standard for connection technology and electrical interconnections. The item's dimensions are (65.1 x 48.6 x 78.9) mm (width x height x depth). Feedthrough terminal block is suitable for conductor cross sections ranging from 1.5 mm<sup>2</sup> to 16 mm<sup>2</sup>.

Tin is used for coating the contact surfaces.

## Notes

Variants:

Other pole numbers  
 Adapters for varying sheet panel thicknesses  
 Direct marking  
 Other versions (or variants) can be requested from WAGO Sales or configured at <https://configurator.wago.com/>.

## Electrical data

Ratings per	IEC/EN 60664-1			Approvals per	UL 1059		
Overvoltage category	III	III	II	Use group	B	C	D
Pollution degree	3	2	2	Rated voltage	600 V	600 V	-
Nominal voltage	1000 V	1000 V	1000 V	Rated current	30 A	30 A	-
Rated impulse withstand voltage	8 kV	8 kV	8 kV				
Rated current	57 A	57 A	57 A				

Approvals per	CSA		
Use group	B	C	D
Rated voltage	600 V	600 V	-
Rated current	30 A	30 A	-

## Connection Data

Clamping units	8	<b>Connection 1</b>	
Total number of potentials	4	Connection technology	CAGE CLAMP®
Number of connection types	2	Actuation type	Lever
Number of levels	1	Solid conductor	1.5 ... 16 mm <sup>2</sup> / 16 ... 6 AWG
		Fine-stranded conductor	1.5 ... 16 mm <sup>2</sup> / 16 ... 6 AWG
		Fine-stranded conductor; with insulated ferrule	1.5 ... 10 mm <sup>2</sup>
		Fine-stranded conductor; with uninsulated ferrule	1.5 ... 10 mm <sup>2</sup>
		Strip length	12 ... 13 mm / 0.47 ... 0.51 inches
		Pole number	4

## Physical data

Pin spacing	11.5 mm / 0.453 inches
Width	65.1 mm / 2.563 inches
Height	48.6 mm / 1.913 inches
Depth	78.9 mm / 3.106 inches

## Mechanical data

Housing sheet thickness	3 ... 3 mm / 0.118 ... 0.118 inches
Mounting type	Locking claw
Mounting type	Feed-through mounting
Suitable for through-panel applications	Yes

### Material data

Note (material data)	<a href="#">Information on material specifications can be found here</a>
Color	gray
Material group	I
Insulation material (main housing)	Polyamide (PA66)
Flammability class per UL94	V0
Clamping spring material	Chrome-nickel spring steel (CrNi)
Contact material	Electrolytic copper (E <sub>cu</sub> )
Contact Plating	Tin
Fire load	2.393 MJ
Weight	121.9 g

### Environmental requirements

Limit temperature range	-60 ... +105 °C
Processing temperature	-35 ... +60 °C

### Commercial data

Product Group	4 (Printed Circuit Connectors)
PU (SPU)	15 pcs
Packaging type	Box
Country of origin	CN
GTIN	4050821148777
Customs tariff number	85369010000

### Product Classification

UNSPSC	39121410
eCl@ss 10.0	27-14-11-34
eCl@ss 9.0	27-14-11-34
ETIM 9.0	EC001283
ETIM 10.0	EC001283
ECCN	NO US CLASSIFICATION

### Environmental Product Compliance

RoHS Compliance Status	Compliant, No Exemption
SCIP notification number (Austria)	0d734595-b959-4481-9e24-30848b1e4c59
SCIP notification number (Belgium)	9541b29a-e66a-4057-8d23-5fc290967632
SCIP notification number (Bulgaria)	3734b5be-3528-42b4-8a5a-5dd03bb0cea1
SCIP notification number (Czech Republic)	55b8ed86-163e-4a8a-b21e-c45d10ae48d4
SCIP notification number (Denmark)	8d6b435d-e6df-4a1f-9f1a-4ed8f880bc26
SCIP notification number (Finland)	ee92680d-3320-41b2-950e-1552139d0615
SCIP notification number (France)	82d1ef36-b6a7-4ec7-a933-9ee44eff2a31
SCIP notification number (Germany)	53c0bf5c-8b50-4ab0-a882-e0acad435acd
SCIP notification number (Hungary)	75a68f21-0f78-446a-84a7-00b131e85d43
SCIP notification number (Italy)	bccf2cba-dc35-4397-ab96-91173936d8fa
SCIP notification number (Netherlands)	2c2b2543-7430-49d7-bd72-5293c711a5a6
SCIP notification number (Poland)	87b40070-b129-4cf7-9aab-3462de5f5d5c
SCIP notification number (Romania)	c0b2317f-ecc7-4117-8873-9a67a067a90c
SCIP notification number (Sweden)	e495909f-40dd-4a6f-be51-7ceb74fe1f28

**Approvals / Certificates**

**General approvals**



Approval	Standard	Certificate Name
CCA DEKRA Certification B.V.	EN 60947	NTR NL-7760
CCA DEKRA Certification B.V.	EN 60947	71-1082983
CSA DEKRA Certification B.V.	C22.2 No. 158	2059958
UL UL International Germany GmbH	UL 1059	E45172

**Declarations of conformity and manufacturer's declarations**

Approval	Standard	Certificate Name
EU-Declaration of Conformity WAGO GmbH & Co. KG	-	-
UK-Declaration of Conformity WAGO GmbH & Co. KG	-	-

**Downloads**

**Environmental Product Compliance**

Compliance Search
Environmental Product Compliance 828-334

**Documentation**

Additional Information
Technical Section 03.04.2019 pdf 2027.26 KB

**CAD/CAE-Data**

CAE data
WSCAD Universe 828-334

**1 Compatible Products**

**1.1 Optional Accessories**

**1.1.1 Ferrule**

**1.1.1.1 Ferrule**



**Item No.: 216-264**  
Ferrule; Sleeve for 1.5 mm<sup>2</sup> / AWG 16; insulated; electro-tin plated; electrolytic copper; gastight crimped; acc. to DIN 46228, Part 4/09.90; black

**Item No.: 216-209**  
Ferrule; Sleeve for 10 mm<sup>2</sup> / AWG 8; insulated; electro-tin plated; red

**Item No.: 216-109**  
Ferrule; Sleeve for 10 mm<sup>2</sup> / AWG 8; uninsulated; electro-tin plated

**Item No.: 216-266**  
Ferrule; Sleeve for 2.5 mm<sup>2</sup> / AWG 14; insulated; electro-tin plated; electrolytic copper; gastight crimped; acc. to DIN 46228, Part 4/09.90; blue

### 1.1.1.1 Ferrule



**Item No.: 216-267**

Ferrule; Sleeve for 4 mm<sup>2</sup> / AWG 12; insulated; electro-tin plated; electrolytic copper; gastight crimped; acc. to DIN 46228, Part 4/09.90; gray

**Item No.: 216-208**

Ferrule; Sleeve for 6 mm<sup>2</sup> / AWG 10; insulated; electro-tin plated; electrolytic copper; gastight crimped; acc. to DIN 46228, Part 4/09.90; yellow

**Item No.: 216-108**

Ferrule; Sleeve for 6 mm<sup>2</sup> / AWG 10; uninsulated; electro-tin plated; silver-colored

## Installation Notes

### Installation

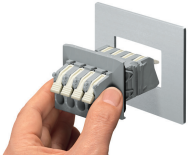

Insert terminal strip from the outside.

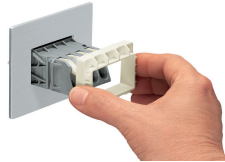

Snap the panel thickness adapter on from the inside.



Secure to panel via locking clip.

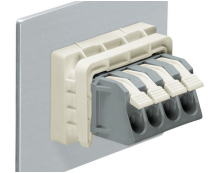

Mounted feedthrough terminal strip (internal)