

Weitergabe sowie Vervielfältigung dieser Unterlage, Verwertung und Mitteilung ihres Inhalts nicht gestattet, soweit nicht ausdrücklich zugestanden. Zuwiderhandlungen verpflichten zu Schadensersatz. Alle Rechte für den Fall der Patenterteilung oder Gebrauchsmuster-Eintragung vorbehalten.

Copying of this document and giving it to others and the use or communication of the contents thereof, are forbidden without express authority. Offenders are liable to the payment of damages. All rights are reserved in the event of the grant of a patent or the registration of the utility model or design.

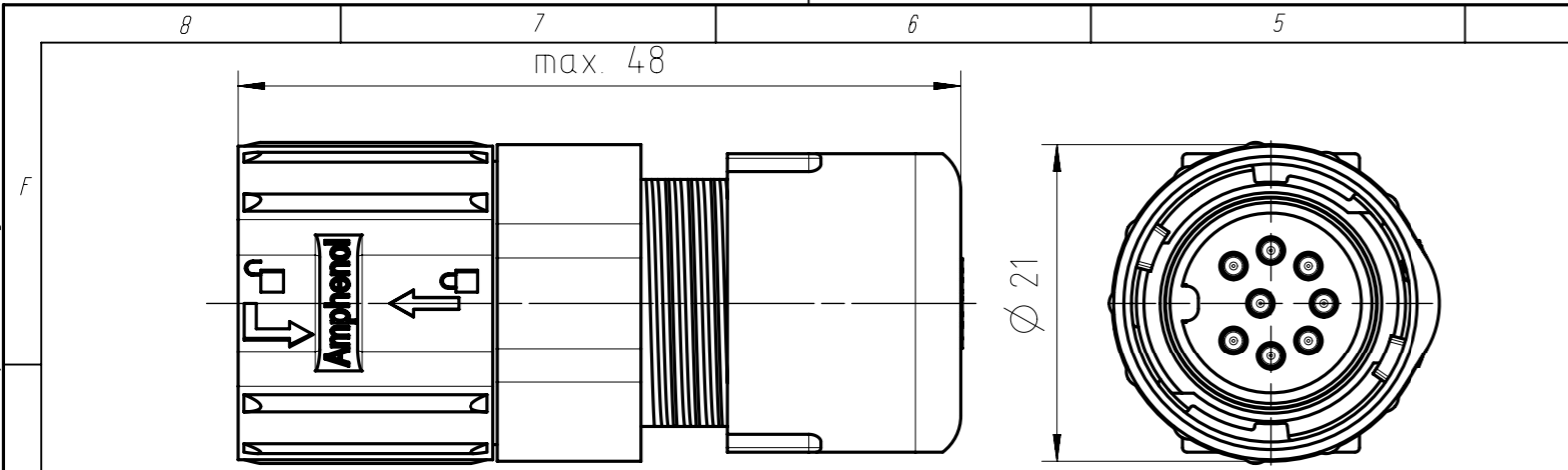

Assembly instruction see N 22 091 0034

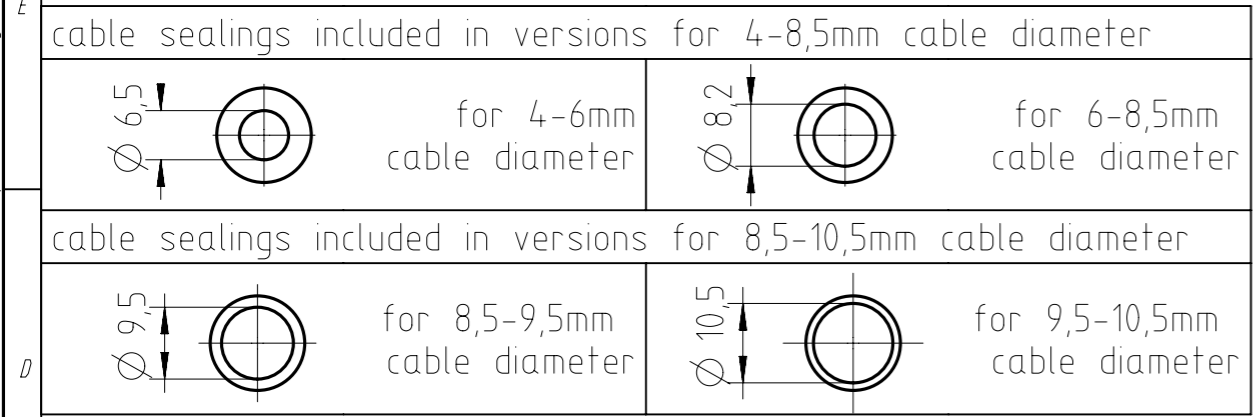

Number of contacts	Standard	3	4	5	5	6	7	7	8	12	14	14	19
Contact arrangement	IEC 61076-2-106	03-a	04-a	05-a	05-b	06-a	07-a	07-b	08-a	12-a	14-a	14-b	19-a
Rated voltage	IEC 60664-1	150 V		100 V	32 V	100 V			32 V				
Rated impulse withstand voltage	IEC 60664-1	840 V			500 V	840 V			500 V				
Pollution degree ²⁾	IEC 60664-1	3 ¹⁾											
Installation category	IEC 60664-1	I											
Insulation group	IEC 60664-1	II, 400 ≤ CTI < 600											
Current rating	IEC 60512-5-2 UL 1977	10A/+40°C			7A/+40°C					3A/+40°C			
Insulation resistance	IEC 60512-3-1	>10 ¹⁰ Ohm ²⁾											
Contact resistance	IEC 60512-2-1	<5mOhm											
Climatic category	IEC 60668-1	40 / 100 / 56											
Temperatur range	IEC 60668-1	-40°C...+100°C / -40°F...+212°F											
IP degree	IEC 60529	IP 68 (in mated condition)											
Insertion and withdrawal force	IEC 60512-13-2	25N	30N	35N	35N	50N	55N	55N	60N	50N	50N	50N	60N
mechanical operation	IEC 60512-9-1	≥500 mating cycles											
housing material		thermoplastic											
dielectric material		thermoplastic											
sealing material		chloroprene, silicone											
contacts		silver or gold plated											
termination technique		solder											
wire gauge		≤0,5mm ² / 20 AWG						≤0,35mm ² / 22 AWG					
flamability		UL 94 V0											
locking system	IEC 60130-9 DIN EN 61076-2-106	Quicklock system											

	19 (19-a)	Ag	C091 31H019 100 5 U	C091 31H019 102 5 U
		Au	C091 31H019 200 5 U	C091 31H019 202 5 U
	14 (14-b)	Ag	C091 31H114 100 5 U	C091 31H114 102 5 U
		Au	C091 31H114 200 5 U	C091 31H114 202 5 U
	14 (14-a)	Ag	C091 31H014 100 5 U	C091 31H014 102 5 U
		Au	C091 31H014 200 5 U	C091 31H014 202 5 U
	12 (12-a)	Ag	C091 31H012 100 5 U	C091 31H012 102 5 U
		Au	C091 31H012 200 5 U	C091 31H012 202 5 U
	8 (08-a)	Ag	C091 31H008 100 5 U	C091 31H008 102 5 U
		Au	C091 31H008 200 5 U	C091 31H008 202 5 U
	7 (07-b)	Ag	C091 31H107 100 5 U	C091 31H107 102 5 U
		Au	C091 31H107 200 5 U	C091 31H107 202 5 U
	7 (07-a)	Ag	C091 31H007 100 5 U	C091 31H007 102 5 U
		Au	C091 31H007 200 5 U	C091 31H007 202 5 U
	6 (6-a)	Ag	C091 31H006 100 5 U	C091 31H006 102 5 U
		Au	C091 31H006 200 5 U	C091 31H006 202 5 U
	5 (05-b)	Ag	C091 31H105 100 5 U	C091 31H105 102 5 U
		Au	C091 31H105 200 5 U	C091 31H105 202 5 U
	5 (05-a)	Ag	C091 31H005 100 5 U	C091 31H005 102 5 U
		Au	C091 31H005 200 5 U	C091 31H005 202 5 U
	4 (04-a)	Ag	C091 31H004 100 5 U	C091 31H004 102 5 U
		Au	C091 31H004 200 5 U	C091 31H004 202 5 U
	3 (03-a)	Ag	C091 31H003 100 5 U	C091 31H003 102 5 U
		Au	C091 31H003 200 5 U	C091 31H003 202 5 U
	05 2 (Pin 1+3)	Ag	C091 31H002 100 5 U	C091 31H002 102 5 U
		Au	C091 31H002 200 5 U	C091 31H002 202 5 U
Contact arrangement View on mating side	Number of contacts (Contact arrangement acc. DIN EN 61076-2-106)	contact plating	Part number for cable diameters 4-8,5mm	Part number for cable diameters 8,5-10,5mm

¹⁾ designed acc. pollution degree 2; can be used under pollution degree 3 when the rules of IEC 60664-1 are fulfilled

²⁾ under operating conditions >10⁸ Ohm

Do not connect or disconnect under load. Metal housing parts shall be securely incorporated to protected ground.

Remark for gold plated contacts:
In order to avoid brittle inter-metallic connections, gold plated terminals have to be tin-plated in the solder area.

All technical data have been measured in a laboratory environment and can be different during practical usage of the product. Any product information is for descriptive usage only and not legally binding; particularly the information does not constitute or provide any legal guaranties ("Beschaffungsgarantie" or "Haltbarkeitsgarantie").

Gewicht (errechnet) / Calc WT:		Zul. Abw./Tolerances:		Maßstab / Scale: 2:1		A3			
Prüfmaß / Testdimension		± 0,50		DIN / ISO 13715		CUSTOMER DRAWING			
Teileindex / Partindexnumber:									
Bagatelle change:						Kabelstecker Quicklock Male cable connector Quicklock			
		Gez. 11.09.2020		M		C091 31HXXX X0X 5 U			
		Drawn MCARLE							
		Status Released				Blatt / Sheet 1			
		Gepr. 20.02.2023							
		Checked MBERTSCH				1 Bl.			
Index		Änderung / Description		Datum / Date		Name		Ers. f. / Replacement for:	
05	202300020	17.02.2023	MCARLE						
04	201800273	21.07.2021	MCARLE						
03	201800273	24.06.2021	MCARLE						
02	201800273	17.06.2021	MCARLE						
01	201800273	27.11.2020	MCARLE						