

Data Sheet | Item Number: 721-840/001-000

THT male header; 1.0 x 1.0 mm solder pin; angled; 100% protected against mismatching; Pin spacing 7.5 mm; 10-pole; light gray

<https://www.wago.com/721-840/001-000>

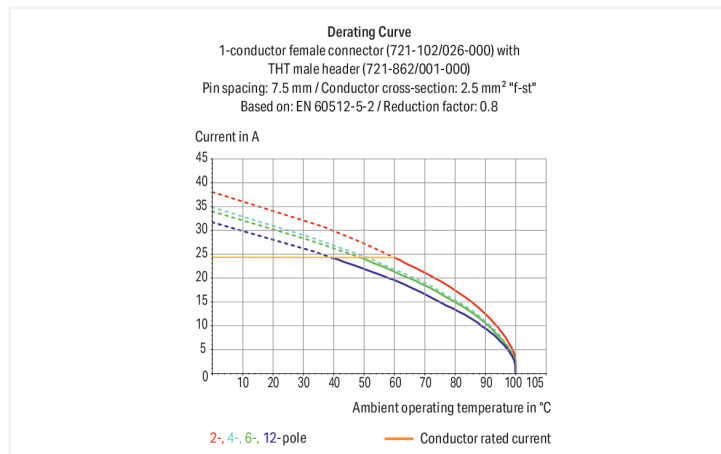

Color: ■ light gray

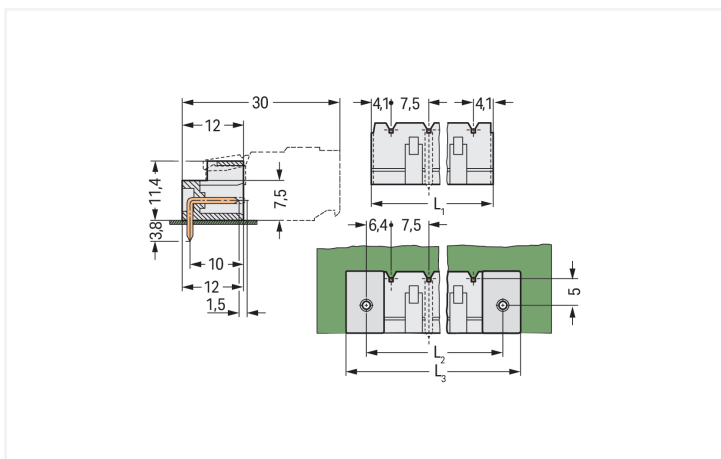

Dimensions in mm

$L1 = (\text{pole no.} - 1) \times \text{pin spacing} + 8.2 \text{ mm}$
 $L2 = L1 + 5 \text{ mm}$
 $L3 = L2 + 7.4 \text{ mm}$

Male connector, 721 Series, solder pin dimensions 1 x 1 mm

This male connector (item number 721-840/001-000) provides seamless electrical installations. The item's dimensions are (75.7 x 15.2 x 12) mm (width x height x depth).

Tin is used for coating the contact surfaces. THT is used to solder the pcb connector.

Notes

Safety Information

The MCS – MULTI CONNECTION SYSTEM includes connectors without breaking capacity in accordance with DIN EN 61984. When used as intended, these connectors must not be connected/disconnected when live or under load. When used as intended, these connectors must not be connected/disconnected when live or under load. The circuit design should ensure header pins, which can be touched, are not live when unmated.

Variants:

Other pole numbers
3.8 mm pin projection for male headers with straight solder pins
Gold-plated or partially gold-plated contact surfaces
Other versions (or variants) can be requested from WAGO Sales or configured at <https://configurator.wago.com/>.

Electrical data

| Ratings per | IEC/EN 60664-1 | | |
|---------------------------------|----------------|-------|--------|
| Overvoltage category | III | III | II |
| Pollution degree | 3 | 2 | 2 |
| Nominal voltage | 500 V | 630 V | 1000 V |
| Rated impulse withstand voltage | 6 kV | 6 kV | 6 kV |
| Rated current | 12 A | 12 A | 12 A |

| Approvals per | UL 1059 | | |
|---------------|---------|---|-------|
| Use group | B | C | D |
| Rated voltage | 300 V | - | 300 V |
| Rated current | 15 A | - | 10 A |

| Approvals per | UL 1977 |
|---------------|---------|
| Rated voltage | 600 V |
| Rated current | 10 A |

| Approvals per | CSA | | |
|---------------|-------|---|-------|
| Use group | B | C | D |
| Rated voltage | 300 V | - | 300 V |
| Rated current | 15 A | - | 10 A |

Connection Data

| | |
|----------------------------|----|
| Total number of potentials | 10 |
| Number of connection types | 1 |
| Number of levels | 1 |

| Connection 1 | |
|--------------|----|
| Pole number | 10 |

Physical data

| | |
|-------------------------|--------------------------|
| Pin spacing | 7.5 mm / 0.295 inches |
| Width | 75.7 mm / 2.98 inches |
| Height | 15.2 mm / 0.598 inches |
| Height from the surface | 11.4 mm / 0.449 inches |
| Depth | 12 mm / 0.472 inches |
| Solder pin length | 3.8 mm |
| Solder pin dimensions | 1 x 1 mm |
| Drilled hole diameter | 1.4 ^(+0.1) mm |

Mechanical data

| | |
|--------------------------|-----|
| Variable coding | Yes |
| Anti-rotation protection | Yes |

Plug-in connection

| | |
|------------------------------------|---------------------|
| Contact type (pluggable connector) | Male connector/plug |
| Connector (connection type) | for PCB |
| Mismating protection | Yes |
| Mating direction to the PCB | 0° |

PCB contact

| | |
|-------------------------------------|--|
| PCB contact | THT |
| Solder pin arrangement | over the entire male connector (in-line) |
| Number of solder pins per potential | 1 |

Material data

| | |
|------------------------------------|--|
| Note (material data) | Information on material specifications can be found here |
| Color | light gray |
| Material group | I |
| Insulation material (main housing) | Polyamide (PA66) |
| Flammability class per UL94 | V0 |
| Contact material | Electrolytic copper (E _{Cu}) |
| Contact Plating | Tin |
| Fire load | 0.073 MJ |
| Weight | 4 g |

Environmental requirements

| | |
|-------------------------|-----------------|
| Limit temperature range | -60 ... +100 °C |
| Processing temperature | -35 ... +60 °C |

Environmental Testing

| | |
|---|---|
| Test specification: Railway applications – Rolling stock – Electronic equipment | DIN EN 50155 (VDE 0115-200):2022-06 |
| Test procedure: Railway applications – Rolling stock equipment – Vibration and shock tests | DIN EN 61373 (VDE 0115-0106):2011-04 |
| Spectrum/Mounting location | Service life test, Category 1, Class A/B |
| Functional test with noise-like oscillations | Test passed according to Section 8 of the standard |
| Frequency | f ₁ = 5 Hz to f ₂ = 150 Hz |
| Acceleration | 0.101g (highest test level used for all axes) |
| Test duration per axis | 10 min. |
| Test directions | X, Y and Z axes |
| Monitoring of contact faults and interruptions | Passed |
| Voltage drop measurement before and after each axis | Passed |
| Simulated service life test through increased levels of noise-like oscillations | Test passed according to Section 9 of the standard |
| Frequency | f ₁ = 5 Hz to f ₂ = 150 Hz |
| Acceleration | 0.572g (highest test level used for all axes) |
| Test duration per axis | 5 h |
| Test directions | X, Y and Z axes |
| Extended testing: Monitoring of contact faults and interruptions | Passed |
| Extended testing: Voltage drop measurement before and after each axis | Passed |
| Shock test | Test passed according to Section 10 of the standard |
| Shock pulse form | Half sine |

Environmental Testing

| | |
|---|---|
| Acceleration | 5g (highest test level used for all axes) |
| Shock duration | 30 ms |
| Number of shocks (per axis) | 3 pos. und 3 neg. |
| Test directions | X, Y and Z axes |
| Extended testing: Monitoring of contact faults and interruptions | Passed |
| Extended testing: Voltage drop measurement before and after each axis | Passed |
| Vibration and shock stress for rolling stock equipment | Passed |

Commercial data

| | |
|-----------------------|------------------------|
| Product Group | 3 (Multi Conn. System) |
| PU (SPU) | 50 pcs |
| Packaging type | Box |
| Country of origin | PL |
| GTIN | 4044918870092 |
| Customs tariff number | 85366930000 |

Product Classification

| | |
|-------------|----------------------|
| UNSPSC | 39121409 |
| eCl@ss 10.0 | 27-44-04-02 |
| eCl@ss 9.0 | 27-44-04-02 |
| ETIM 9.0 | EC002637 |
| ETIM 10.0 | EC002637 |
| ECCN | NO US CLASSIFICATION |

Environmental Product Compliance

| | |
|------------------------|-------------------------|
| RoHS Compliance Status | Compliant, No Exemption |
|------------------------|-------------------------|

Approvals / Certificates

General approvals

Declarations of conformity and manufacturer's declarations



| Approval | Standard | Certificate Name |
|---------------------------------------|-----------|------------------|
| CB DEKRA Certification B.V. | IEC 61984 | NL-113351 |
| CSA DEKRA Certification B.V. | C22.2 | 1466354 |
| KEMA/KEUR DEKRA Certification B.V. | EN 61984 | 71-130478 REV.1 |
| UL Underwriters Laboratories Inc. | UL 1059 | E45172 |
| UR Underwriters Laboratories Inc. | UL 1977 | E 45171 |

| Approval | Standard | Certificate Name |
|-------------------------------|----------|------------------|
| Railway WAGO GmbH & Co. KG | - | Railway Ready |

Approvals for marine applications



| Approval | Standard | Certificate Name |
|---|-----------|------------------|
| ABS American Bureau of Ship- ping | - | 24-0095975-PDA |
| BV Bureau Veritas S.A. | IEC 60998 | 11915/E0 BV |

Downloads

Environmental Product Compliance

| Compliance Search | |
|--|---|
| Environmental Product Compliance 721-840/001-000 | ↓ |

Documentation

| Additional Information | | | |
|------------------------|------------|-------------------|---|
| Technical Section | 03.04.2019 | pdf 2027.26 KB | ↓ |

CAD/CAE-Data

| CAD data | |
|---------------------------------|---|
| 2D/3D Models 721-840/001-000 | ↓ |

| CAE data | |
|--------------------------------------|---|
| EPLAN Data Portal 721-840/001-000 | ↓ |

| | |
|---------------------------------|---|
| ZUKEN Portal 721-840/001-000 | ↓ |
|---------------------------------|---|

PCB Design

| | |
|---|---|
| Symbol and Footprint via SamacSys 721-840/001-000 | ↓ |
|---|---|

| | |
|--|---|
| Symbol and Footprint via Ultra Librarian 721-840/001-000 | ↓ |
|--|---|

1 Compatible Products

1.1 System counterpart

1.1.1 Female connector/socket



Item No.: 721-210/026-000
 1-conductor female connector; CAGE CLAMP®; 2.5 mm²; Pin spacing 7.5 mm; 10-pole; 100% protected against mismatching; 2,50 mm²; light gray



Item No.: 721-210/031-000
 1-conductor female connector; CAGE CLAMP®; 2.5 mm²; Pin spacing 7.5 mm; 10-pole; 100% protected against mismatching; clamping collar; 2,50 mm²; light gray



Item No.: 721-210/026-045
 1-conductor female connector; CAGE CLAMP®; 2.5 mm²; Pin spacing 7.5 mm; 10-pole; 100% protected against mismatching; direct marking; 2,50 mm²; light gray



Item No.: 721-210/037-000
 1-conductor female connector; CAGE CLAMP®; 2.5 mm²; Pin spacing 7.5 mm; 10-pole; 100% protected against mismatching; Lateral locking levers; 2,50 mm²; light gray



Item No.: 2721-210/026-000
 1-conductor female connector; push-button; Push-in CAGE CLAMP®; 2.5 mm²; Pin spacing 7.5 mm; 10-pole; 100% protected against mismatching; 2,50 mm²; light gray



Item No.: 2721-210/031-000
 1-conductor female connector; push-button; Push-in CAGE CLAMP®; 2.5 mm²; Pin spacing 7.5 mm; 10-pole; 100% protected against mismatching; clamping collar; 2,50 mm²; light gray



Item No.: 2721-210/037-000
 1-conductor female connector; push-button; Push-in CAGE CLAMP®; 2.5 mm²; Pin spacing 7.5 mm; 10-pole; 100% protected against mismatching; Lateral locking levers; 2,50 mm²; light gray



Item No.: 721-2210/037-000
 2-conductor female connector; Push-in CAGE CLAMP®; 2.5 mm²; Pin spacing 7.5 mm; 10-pole; 100% protected against mismatching; Lateral locking levers; 2,50 mm²; light gray



Item No.: 721-2210/026-000
 2-conductor female connector; Push-in CAGE CLAMP®; 2.5 mm²; Pin spacing 7.5 mm; 10-pole; 100% protected against mismatching; with integrated end plate; 2,50 mm²; light gray

1.2 Optional Accessories

1.2.1 Coding

1.2.1.1 Coding



Item No.: 231-130
 Coding key; snap-on type; light gray

1.2.2 Marking

1.2.2.1 Marking strip



Item No.: 210-833
 Marking strips; 25 m on roll; 6 mm wide; plain; Self-adhesive; white



Item No.: 210-834
 Marking strips; on reel; 5 mm wide; plain; Self-adhesive; white

Installation Notes

Coding

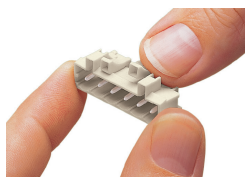

Coding a male header – fitting coding key (s).