

## Data Sheet | Item Number: 216-106

Ferrule; Sleeve for 2.5 mm<sup>2</sup> / AWG 14; uninsulated; electro-tin plated; silver-colored

<https://www.wago.com/216-106>

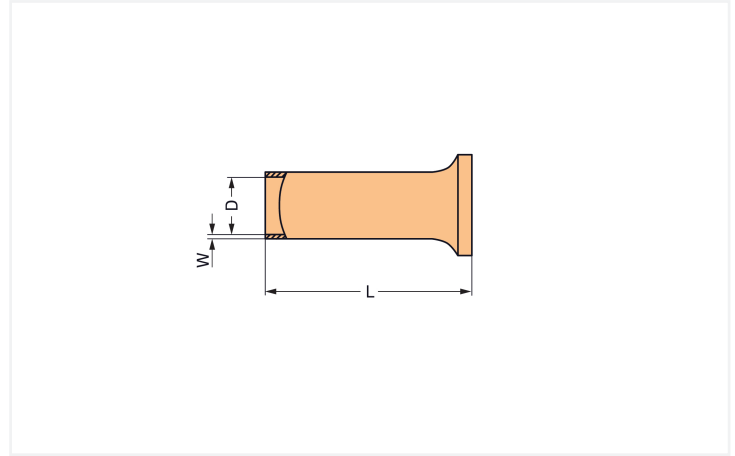

Color: ■ silver-colored

Dimensions in mm

### Connection Data

Metric cross-section of the ferrule	2.5 mm <sup>2</sup>
Strip length	10 mm / 0.39 inches
Cross-section (AWG) of ferrule	14 AWG

### Physical data

Total length	10 mm
Wall thickness of crimp sleeve	0.2 mm
Diameter crimp sleeve inside	2.1 mm

### Mechanical data

Plastic collar	No
----------------	----

### Material data

Color	silver-colored
Weight	0.1 g

### Commercial data

Product Group	2 (Terminal Block Accessories)
PU (SPU)	5000 (1000) pcs
Packaging type	Box
Country of origin	DE
GTIN	4017332277686
Customs tariff number	85369010000

### Product Classification

UNSPSC	39121405
eCl@ss 10.0	27-40-02-01
eCl@ss 9.0	27-40-02-01
ETIM 9.0	EC000005
ETIM 10.0	EC000005
ECCN	NO US CLASSIFICATION

### Environmental Product Compliance

RoHS Compliance Status	Compliant, No Exemption
------------------------	-------------------------

### Downloads

#### Environmental Product Compliance

Compliance Search	
Environmental Product Compliance 216-106	<a href="#">↓</a>

### Documentation

Bid Text			
216-106	11.09.2017	doc 24.00 KB	<a href="#">↓</a>
216-106	19.02.2019	xml 2.77 KB	<a href="#">↓</a>

### Installation Notes

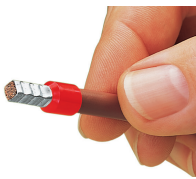

A perfect gas-tight crimp – both electrically and mechanically reliable

Subject to changes. Please also observe the further product documentation!

Current addresses can be found at: [www.wago.com](https://www.wago.com)