

| REVISIONS | | | | | |
|-----------|-----|---------------------------|-----------|-----|------|
| P | LTR | DESCRIPTION | DATE | DWN | APVD |
| A | | REVISED PER ECN-25-302719 | 22JAN2025 | TR | RCG |

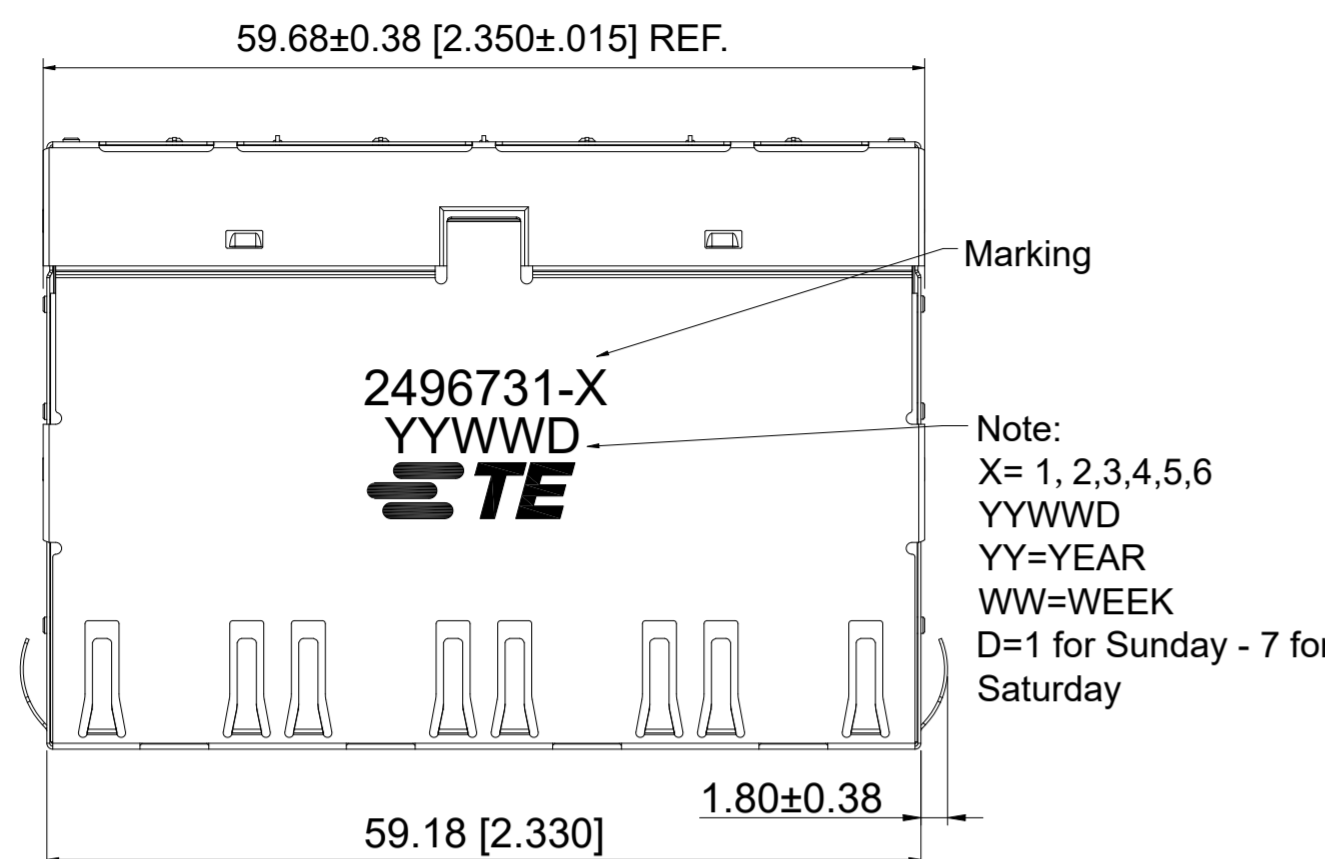

- NOTE :**
- 1.HOUSING:GLASS FILLED PA6T(BLACK) UL94V-0(RoHS)
 - 2.CONTACT: PHOSPHOR BRONZE,50 MICROINCHES MIN. OVERALL DUCTILE NICKEL UNDERPLATE WITH (REFER PART NUMBER TABLE) GOLD AT MATING INTERFACE
 - 3.SHIELD:0.2mm THICKNESS WITH BRASS.
 - 4.JACK CAVITY CONFORMS TO FCC RULES AND REGULATIONS PART 68 SUBPART F
 - 5.THE PART IS RECOMMENDED FOR WAVE SOLDERING PROCESS PEAK SOLDERING TEMPERATURE IS 260°C MAX,10 SECS MAX.
 - 6.OPERATING TEMPERATURE:-40°C TO +85°C.
STORAGE TEMPERATURE:-40°C TO +85°C.

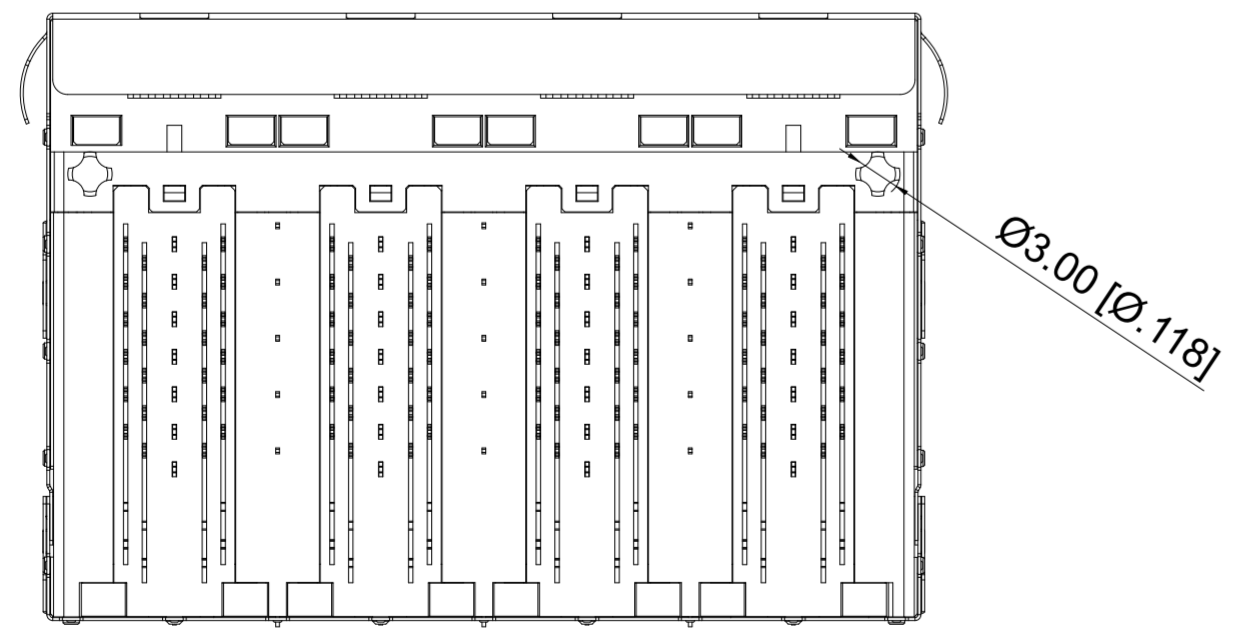
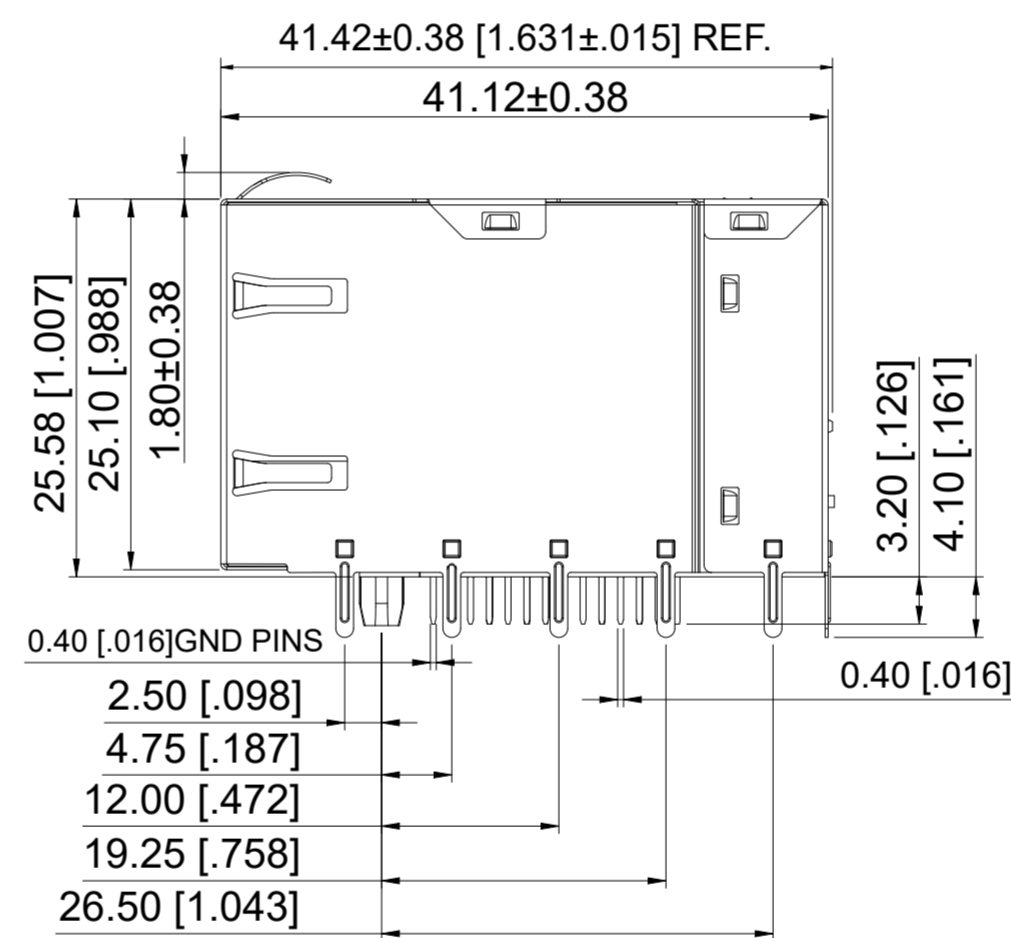
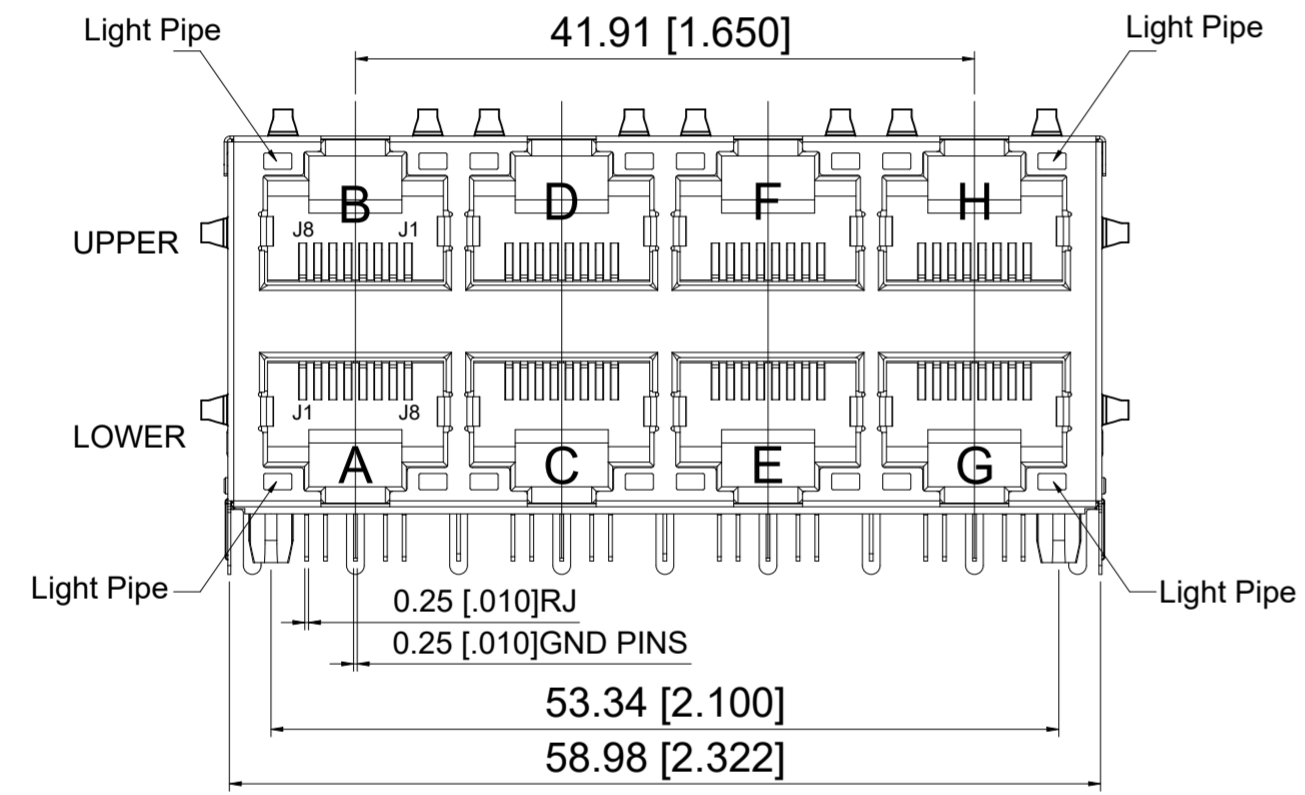

| GOLD PLATING THICKNESS | PART NUMBER |
|------------------------|-------------|
| GF | 2496731-6 |
| 0.0762 µm [3µ"] | 2496731-5 |
| 0.1524 µm [6µ"] | 2496731-4 |
| 0.381 µm [15µ"] | 2496731-3 |
| 0.762 µm [30µ"] | 2496731-2 |
| 1.27 µm [50µ"] | 2496731-1 |

| | | | | |
|---------------------------------------------------------------------------------------|--|-------------------------------------|------------------------------------------|--------------------|
| THIS DRAWING IS A CONTROLLED DOCUMENT. | | DWN TARUN, R 29OCT2024 | TE Connectivity | |
| DIMENSIONS: mm [INCHES] | | CHK RAMESH, KIVADER 30OCT2024 | | |
| TOLERANCES UNLESS OTHERWISE SPECIFIED: | | APVD RAGHAVAN, CG 30OCT2024 | NAME RJ45 W/MAGNET 2X4 10G LIGHT PIPE | |
| 0 PLC ± - 1 PLC ± 0.35 2 PLC ± 0.25 3 PLC ± 0.15 4 PLC ± - ANGLES ± 2° | | PRODUCT SPEC 108-161620 | RESTRICTED TO | |
| MATERIAL | | APPLICATION SPEC 114-161217 | SIZE A2 | CAGE CODE 00779 |
| FINISH | | WEIGHT | DRAWING NO C=2496731 | SCALE 1:1 |
| | | CUSTOMER DRAWING | SHEET 1 OF 3 | REV A |

| P | LTR | DESCRIPTION | DATE | DWN | APVD |
|---|-----|-------------|------|-----|------|
| - | - | SEE SHEET 1 | - | - | - |

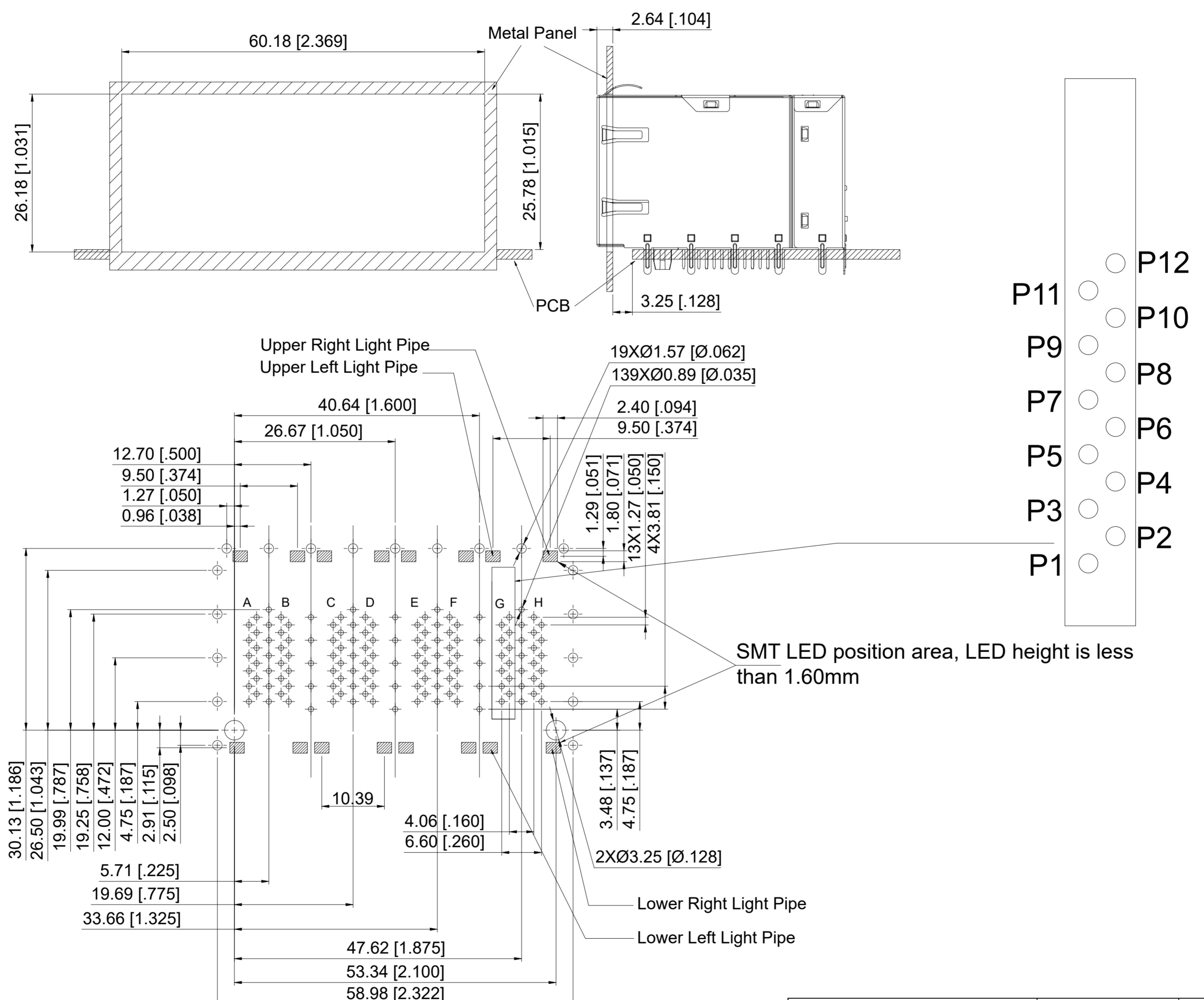

| | | | | |
|---------------------------------------------------------------------------------------|--|-------------------------------------|------------------------------------------|--------------------|
| THIS DRAWING IS A CONTROLLED DOCUMENT. | | DWN TARUN, R 29OCT2024 | | |
| DIMENSIONS: mm [INCHES] | | CHK RAMESH, KIVADER 30OCT2024 | | |
| TOLERANCES UNLESS OTHERWISE SPECIFIED: | | APVD RAGHAVAN, CG 30OCT2024 | NAME RJ45 W/MAGNET 2X4 10G LIGHT PIPE | |
| 0 PLC ± - 1 PLC ± 0.35 2 PLC ± 0.25 3 PLC ± 0.15 4 PLC ± - ANGLES ± 2° | | PRODUCT SPEC 108-161620 | RESTRICTED TO | |
| MATERIAL | | APPLICATION SPEC 114-161217 | SIZE A2 | CAGE CODE 00779 |
| FINISH | | WEIGHT - | DRAWING NO C=2496731 | SCALE 1:1 |
| | | CUSTOMER DRAWING | SHEET 2 OF 3 | REV A |

| REVISIONS | | | | | |
|-----------|-----|-------------|------|-----|------|
| P | LTR | DESCRIPTION | DATE | DWN | APVD |
| - | - | SEE SHEET 1 | - | - | - |

Schematic

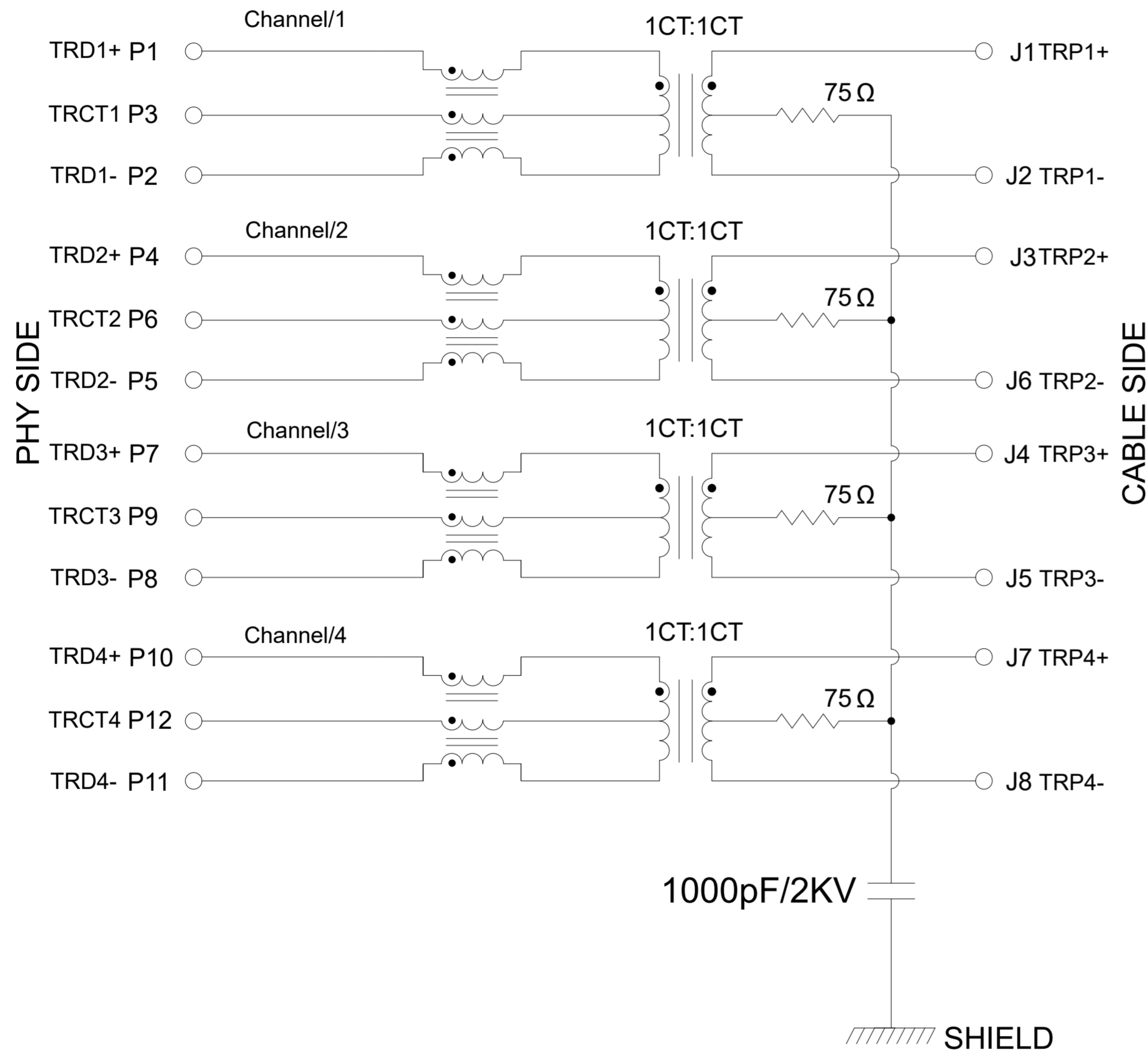

| PARAMETER | SPECIFICATIONS |
|----------------------------------------------|-------------------------------------------------------------|
| OPERATING TEMPERATURE | -40°C To +85°C |
| TURNS RATIO | 1:1±2% |
| INDUCTANCE(OCL) | 120uH MIN@100KHz/100mV With 8mA DC Bias For(Channel1/2/3/4) |
| INSERTION LOSS | -3.0dBMAX@1-500MHz; |
| RETURN LOSS | -22dBMIN@1-100MHz; -22+20.75xLOG(f/100)dBMIN@100-500MHz; |
| CROSSTALK (ADJACENT CHANNELS) | -28dBMIN@1-100MHz; -19dBMIN@100-500MHz; |
| CROSSTALK (PORT TO PORT) | -50dBMIN@1-100MHz; -50dBMIN@100-500MHz; |
| COMMON MODE REJECTION RATIO | -30dBMIN@1-100MHz; -20dBMIN@100-500MHz; |
| COMMON MODE TO DIFFERENTIAL MODE ATTENUATION | -30dBMIN@1-100MHz; -20dBMIN@100-500MHz; |
| HI-POT | 2250VDC@60 SECONDS(Channel1/2/3/4) |

| | | | | |
|---------------------------------------------------------------------------------------|--|-------------------------------------|------------------------------------------|--------------------|
| THIS DRAWING IS A CONTROLLED DOCUMENT. | | DWN TARUN, R 29OCT2024 | | |
| DIMENSIONS: mm [INCHES] | | CHK RAMESH, KIVADER 30OCT2024 | | |
| TOLERANCES UNLESS OTHERWISE SPECIFIED: | | APVD RAGHAVAN, CG 30OCT2024 | NAME RJ45 W/MAGNET 2X4 10G LIGHT PIPE | |
| 0 PLC ± - 1 PLC ± 0.35 2 PLC ± 0.25 3 PLC ± 0.15 4 PLC ± - ANGLES ± 2° | | PRODUCT SPEC 108-161620 | RESTRICTED TO | |
| MATERIAL | | APPLICATION SPEC 114-161217 | SIZE A2 | CAGE CODE 00779 |
| FINISH | | WEIGHT - | DRAWING NO C=2496731 | SCALE 1:1 |
| | | CUSTOMER DRAWING | SHEET 3 OF 3 | REV A |