

8

7

6

5

4

3

2

1

VICOR CONFIDENTIAL

THIS DOCUMENT AND THE DATA DISCLOSED HEREIN OR HEREWITH IS NOT TO BE REPRODUCED, USED OR DISCLOSED IN WHOLE OR IN PART TO ANYONE WITHOUT THE PERMISSION OF VICOR CORP.

REV.	DESCRIPTION	INTL	DATE	APVD
1	RELEASED PER E240317	MGR	07/19/24	RC

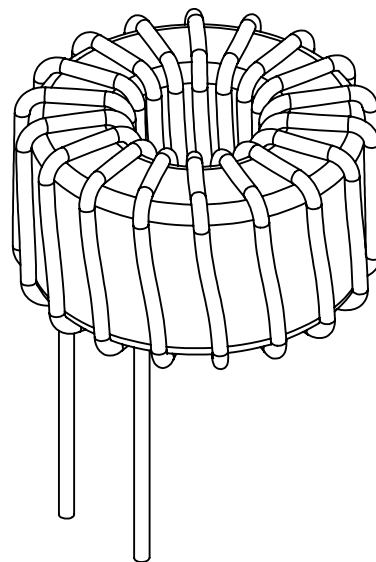
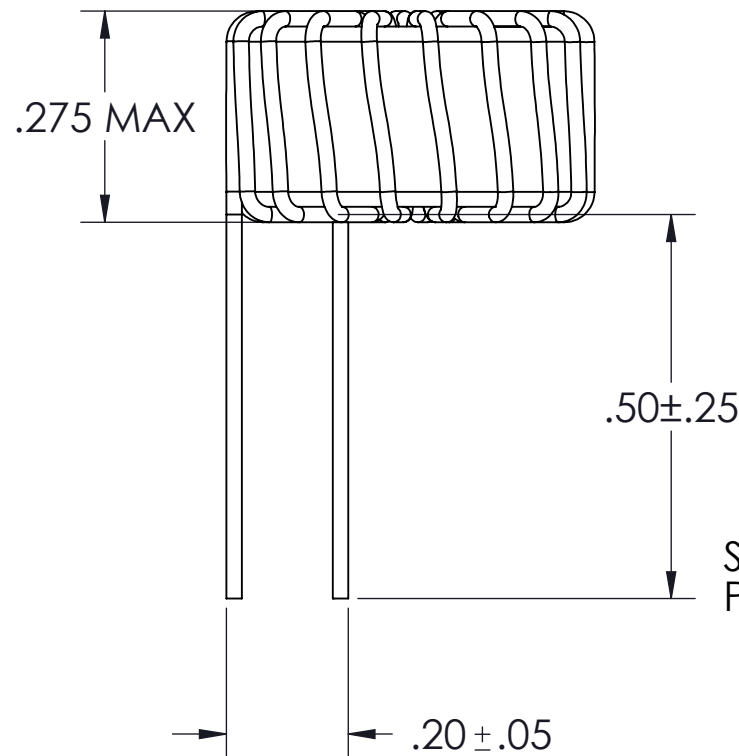

STRIP AND TIN LEADS PER NOTE 3.2

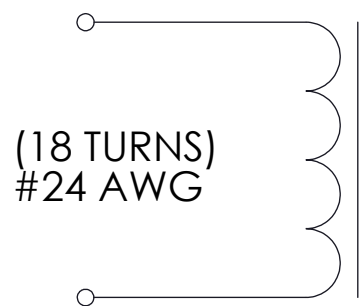
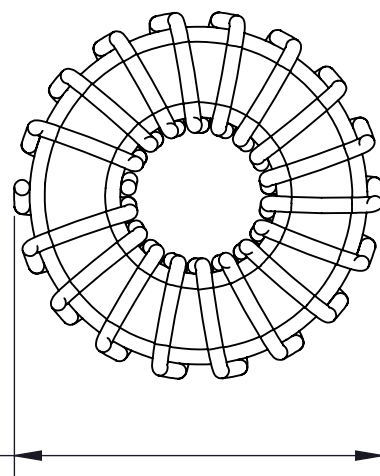

SCHMATIC
TURNS SHOWN FOR REF ONLY

NOTES: UNLESS OTHERWISE SPECIFIED,

1. MATERIALS: UL RECOGNIZED 94V-2 FLAMMABILITY RATING CLASS B (130°C) REQUIRED.
 - 1.1 CORE: TOROID - .375 x .187 x .188 ($\mu = 5000$)
MAGNETICS: ZJ-41005-TC
FAIR-RATE: 5975002501 (COATED)
STEWART: 35T0357-30P
ACME T9.53 X 4.75 X 4.80 A05
 - 1.2 WIRE: U.L. RECOGNIZED 130°C RATING MAGNET WIRE. APPROVED MFR: ESSEX; OTHER MFR HAS TO BE ROHS COMPLIANT CERTIFIED BEFORE USE
2. SPECIFICATIONS:
 - 2.1 L = MIN 0.8-mH @ 100 mV 1 KHz TEST FREQUENCY
 - 2.2 DCR = 35 mOHMS MAX
3. CONSTRUCTION:
 - 3.1 WIND
 - 3.2 TIN LEADS CLOSE TO CORE AS SHOWN
 - 3.3 LABEL BULK PACKAGE WITH DRAWING NUMBER AND REVISION, VENDOR IDENTIFICATION, AND DATE OF MANUFACTURE.

NOTE: CERTIFICATION OF MATERIAL COMPLIANCE REQUIRED. COMPLETED ASSEMBLY MUST BE (RoHS) COMPLIANT PER VICOR SPEC CST-0001

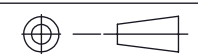
DRAWN BY	DATE	 VICOR		SWD
Matias Gonzalez-Rappe	07/19/2024	INDUCTOR 1 MH TOROID		
UNLESS OTHERWISE SPECIFIED DIMENSIONS ARE : INCH / [MM]				
TOLERANCES ARE:				
DECIMALS		ANGLES		
X.XX [X.XX] = ±0.01 [0.25]		±1°		
X.XXX [X.XXX] = ±0.005 [0.127]				
THIRD ANGLE PROJECTION		SIZE	CAGE CODE	DWG NO
		B	67131	36-00030
DO NOT SCALE DRAWING		REV		
		1		
SCALE 4:1		SHEET 1 OF 1		

8

7

6

5

4

3

2

1