

Click to
ORDER
samples

AMESR-277NZ

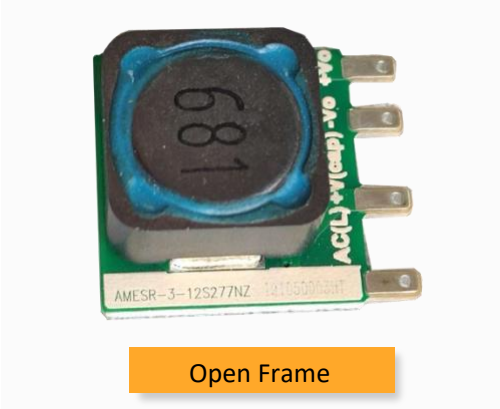

Aimtec's AMESR-277NZ series is a highly efficient, non-isolated AC-DC Converter. It features an ultra-wide wide, 85-305VAC input range accepting either AC or DC voltage, high reliability and low power consumption. All models are particularly suitable for industrial controls, electric power, instrumentation, smart home applications and other applications requiring UL/CE certifications and that have low EMC requirements. We recommend using external components as shown in the recommended application circuit for enhanced EMC performance in harsh environmental conditions.

This new series offers an outstanding operating temperature range of -40°C to 85°C, a high MTBF of 1,500,000h, output short circuit protection (OSCP) and output over-current protection (OCP) come standard with the series.

Features

- Universal Input: 85 - 305VAC/ 120 - 430VDC
- Operating Temp: -40 °C to +85 °C
- Non-isolated
- Low ripple & noise: 150mV (p-p), max.

Summary

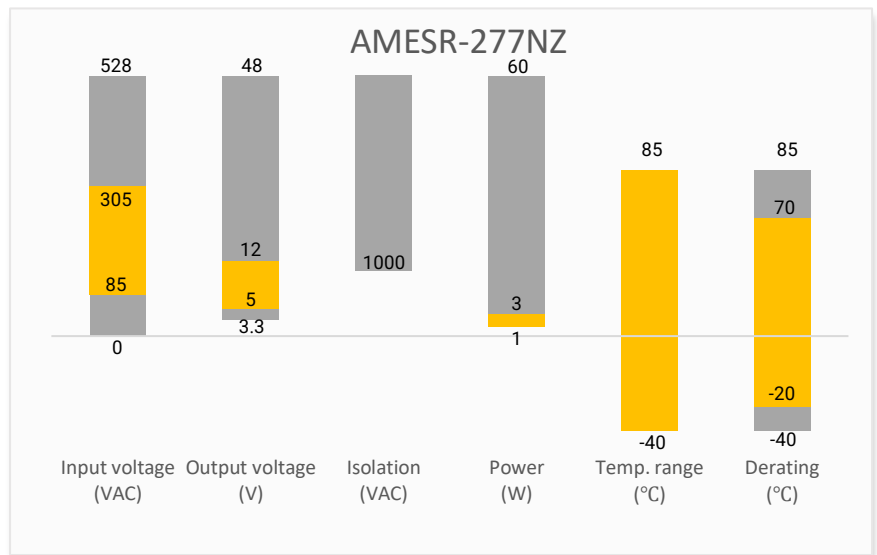

Training



Product Training Video
(click to open)

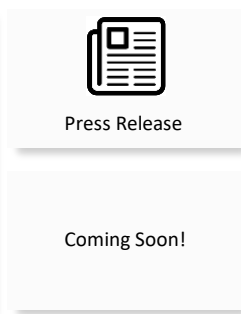

Application Notes

Applications



Power Grid



Industrial



Telecom



Instrumentation

Models & Specifications

Single Output							
Model	Input Voltage (VAC/Hz)	Input Voltage (VDC)	Output Power (W)	Output Voltage (V)	Output Current max (mA)	Maximum capacitive load (μF)	Efficiency @ 230VAC Typ. (%)
AMESR-1-5S277NZ	85~305/47~63	70-430	1	5	200	500	57
AMESR-3-12S277NZ	85~305/47~63	70-430	3	12	250	330	73

Input Specifications				
Parameters	Conditions	Typical	Maximum	Units
Input Current	115VAC		120	mA
	277VAC		60	
Inrush Current	115VAC	25		A
	277VAC	40		
External Input Fuse	1A/300V, slow-blow type			

Output Specifications				
Parameters	Conditions	Typical	Maximum	Units
Voltage accuracy	10%~100% load, 5V output model	± 3	-7 - +3	%
	10%~100% load, 12V output model	± 5	-5 - +8	
Line regulation	Full load, 5V output model	± 1.5		%
	Full load, 12V output model	± 1		
Load regulation	5V output model	± 2.5		%
	12V output model	± 2		
Ripple & Noise	20MHz bandwidth	80	150	mV p-p
No load power consumption	5V output model, input at 230VAC		0.3	W
	12V output model, input at 230VAC		0.4	

General Specifications				
Parameters	Conditions	Typical	Maximum	Units
Over Current protection	auto recovery	≥ 110		% of Iout
Short circuit protection	Hiccup, Continuous, auto recovery			
Operating temperature		-40 to +85		°C
Storage temperature		-40 to +105		°C
Power derating	-40°C to -20°C	2		% / °C
	+70°C to +80°C	2.67		
	85VAC - 100 VAC	0.8		% / VAC
	277VAC – 305 VAC	1.1		
Temperature coefficient		±0.12		% / °C

Minimum load		≥10		%
Cooling	Free air convection			
Storage Humidity			95	% RH
Weight		4.2		g
Dimensions (L x W x H)	0.64 x 0.59 x 0.37 inches (16.13 x 15.1 x 9.50 mm)			
MTBF	> 1 500 000 hrs (MIL-HDBK -217F, t=+25°C)			
NOTE: All specifications in this datasheet are measured at an ambient temperature of 25°C, humidity<75%, nominal input voltage and at rated output load unless otherwise specified.				

Safety Specifications		
Parameters		
Agency approval	CE EN62368-1	
Standards	Designed to meet IEC/UL 62368-1	
	EMC - Conducted and radiated emission	CISPR32 / EN55032 Class A with typical application circuit Class B with EMC recommend circuit
	Electrostatic Discharge Immunity	IEC 61000-4-2 Contact ±6KV, Air ±8KV with typical application circuit, Criteria B
	RF, Electromagnetic Field Immunity	IEC 61000-4-3 10V/m, with EMC recommend circuit, Criteria A
	Electrical Fast Transient/Burst Immunity	IEC 61000-4-4 ±2KV, with typical application circuit, Criteria B IEC 61000-4-4 ±4KV, with EMC recommend circuit, Criteria B
	Surge Immunity	IEC 61000-4-5 L-L ±1KV, with typical application circuit, Criteria B
	CS, Conducted Disturbance Immunity	IEC 61000-4-6 10Vr.m.s, with EMC recommend circuit, Criteria A
	Voltage dips, Short Interruptions Immunity	IEC 61000-4-11 0%, 70%, with EMC recommend circuit, Criteria B

Derating

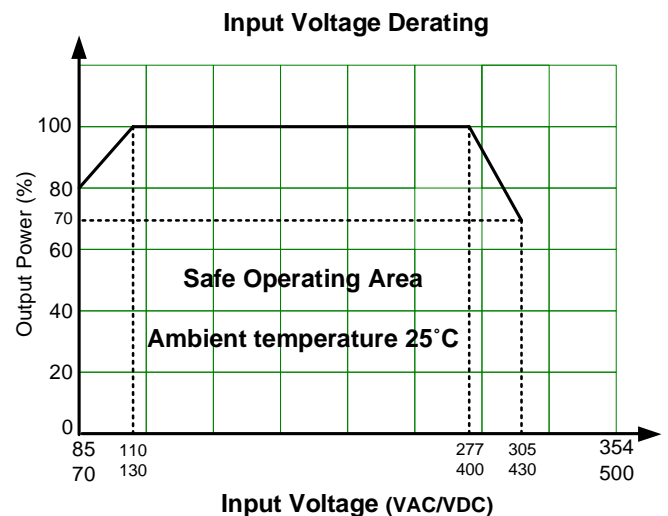
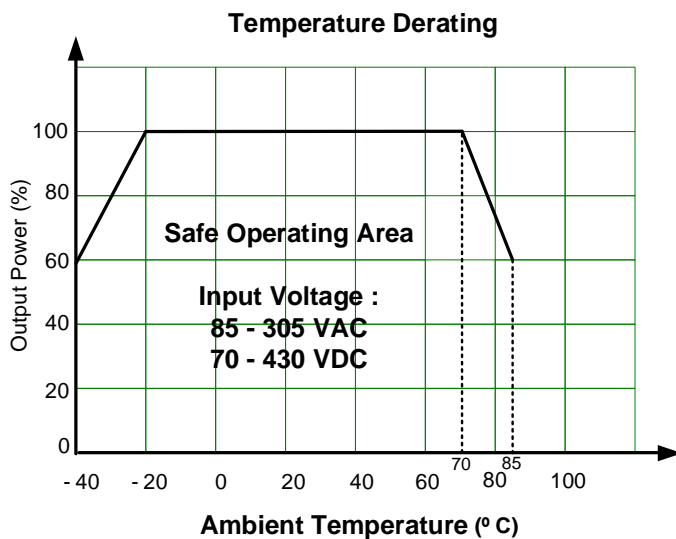

Typical Application Circuit

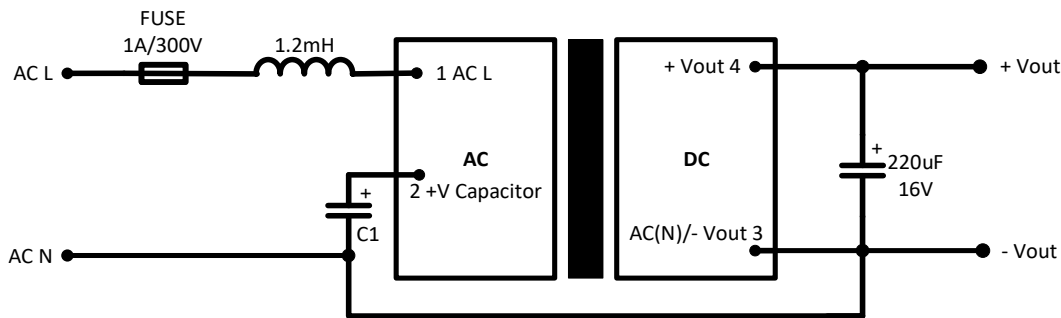

Input voltage	C1
165 – 264VAC	10μF/400V
165 – 305VAC	10μF/450V
85 – 264VAC	22μF/400V
85 – 305VAC	22μF/450V

Note: Use a 22μF capacitor as C1 to meet surge immunity standard.

EMC Recommended Circuit

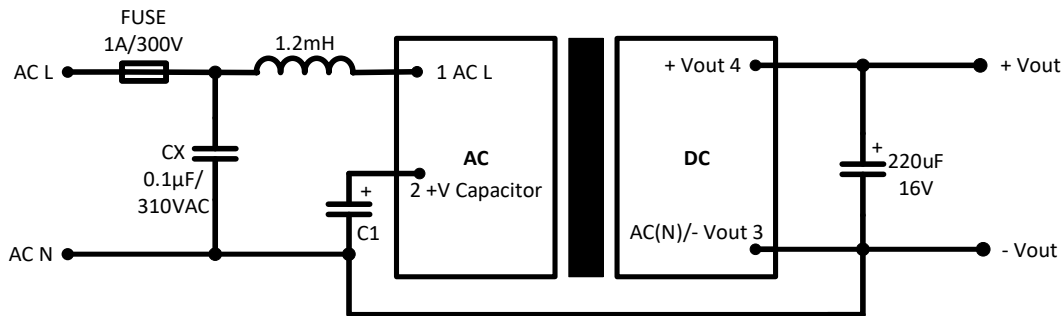

Dimensions

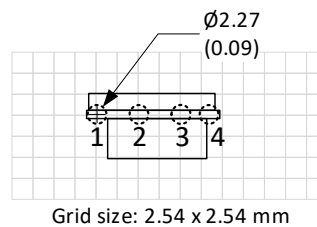
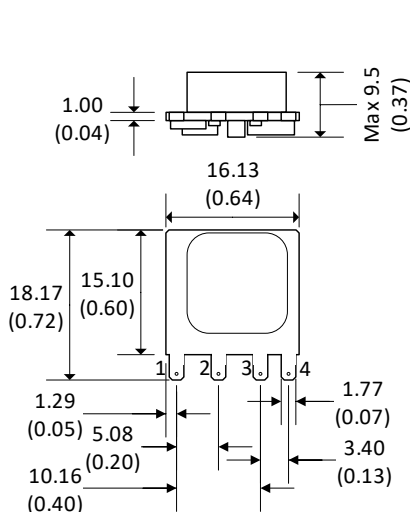

Unit: mm (inch)
General tolerance: ±1.0 (0.04)

Pin Output Specifications	
Pin	Function
1	Input (L)
2	+V Capacitor
3	Input (N)/-V Output
4	+V Output

NOTE: 1. Datasheets are updated as needed and as such, specifications are subject to change without notice. Once printed or downloaded, datasheets are no longer controlled by Aimtec; refer to www.aimtec.com for the most current product specifications. 2. Product labels shown, including safety agency certifications on labels, may vary based on the date manufactured. 3. Mechanical drawings and specifications are for reference only. 4. All specifications are measured at an ambient temperature of 25°C, humidity < 75%, nominal input voltage and at rated output load unless otherwise specified. 5. Aimtec may not have conducted destructive testing or chemical analysis on all internal components and chemicals at the time of publishing this document. CAS numbers and other limited information are considered proprietary and may not be available for release. 6. This product is not designed for use in critical life support systems, equipment used in hazardous environments, nuclear control systems or other such applications which necessitate specific safety and regulatory standards other than the ones listed in this datasheet. 7. Warranty is in accordance with Aimtec's standard Terms of Sale available at www.aimtec.com.