

Micro Battery



Creating Time - Optimizing Time - Enriching Time

Seiko Instruments Inc. (SII), founded in 1937 as a member of the Seiko Group specializing in the manufacture of watches, has leveraged its core competency in high precision watches to create a wide range of new products and technologies.

Over the years SII has developed high-precision processed parts and machine tools that pride themselves on their sub-micron processing capability, quartz crystals that came about as a result of our quartz watch R&D, and electronic components such as micro batteries.

Optimizing our extensive experience and expertise, we have since diversified into such new fields as compact, lightweight, exceedingly quiet thermal printers, and inkjet printheads, a key component in wide format inkjet printers for corporate use.

SII, in the years to come, will maintain an uncompromised dedication to its time-honored technologies and innovations of craftsmanship, miniaturization, and efficiency that meet the needs of our changing society and enrich the lives of those around us.

Genealogy of Seiko Group

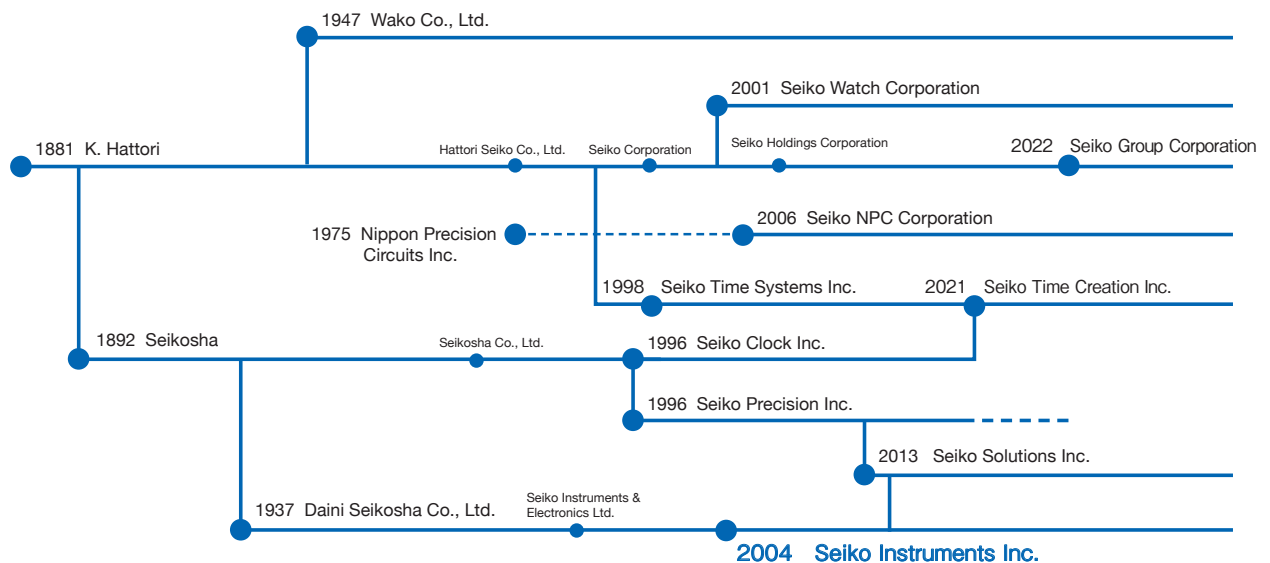

CONTENTS

Product Introduction	3	TS Lithium Rechargeable Battery	18
Micro battery Products Lineup.....	5	Chip Type Electric Double layer Capacitor	20
Example of a Application Circuit.....	6	Mercury Free Silver Oxide Battery : SEIZAIKEN	22
Charging Circuit	7	Selection Check Sheet	24
Reflowable Lithium Rechargeable Battery.....	8	Green Plan and Environmental Policy	25
MS Lithium Rechargeable Battery	10	Precautions for Your Safety	26
MS Lithium Rechargeable Battery <Wide Temperature Range>.....	16		

PRECISION, CRAFTSMANSHIP and MINIATURIZATION

Leveraging Watch Making Technology

🕒 With Precision, we apply our Craftsmanship to provide Miniaturization advantages to customers' product development around the world.

Stable and reliable
Rechargeable Battery & Capacitor

For the IoT product

No corrosion, strong, ultra high elasticity and no magnetization
Superior material
"SPRON"

For material used in harsh environments

For magnetic applied sensor components

For wearable devices

Excellent heat and corrosion resistance
Samarium-cobalt Magnet
"DIANET"

Precise Timing with
Lowest Power consumption

Small and powerful
Silver Oxide Battery
"SEIZAIKEN"

Precise Timing for Electronic Devices

Tuning Fork Quartz Crystal Resonator



Electronic Components and High-performance Materials

SII's electronic components were originally derived from the development and manufacturing of quartz watches.



Since 1953

**No corrosion, strong,
ultra high elasticity
Co-Ni alloy product**

"SPRON"

The sophisticated metal product, "SPRON", was born as a material to be used in a "mainspring", which is a drive source of mechanical watches. "SPRON" has been used for over 50 years as a drive source of watches by utilizing its high elasticity, high strength, and high heat resistance. Evaluated highly for its corrosion resistance and durable quality, "SPRON" is used for key devices in various fields.



Since 1975

**Small and powerful
Silver Oxide Battery
"SEIZAIKEN"**

A small-sized primary battery that features a large electrical capacity and almost no voltage drop until the last stage of electrical discharge even though its minimum diameter is 4.8 mm. Since the birth of quartz watches, we have developed batteries to increase their electrical capacity. We have also pursued better leakage resistance and long term reliability characteristics. It is expected to be used as a power supply for disposable, wearable, IoT, and the low energy Bluetooth products.



Since 1976

**Precise Timing for
Electronic Devices
"Tuning Fork Quartz
Crystal Resonator"**

Tuning Fork Quartz Crystal Resonators were developed as the basis for accuracy in the Quartz Watch. Our high quality and reliability was prioritized to meet the stringent requirements for watches. Recent demand in IoT developments where devices are required to operate with low power consumption and accurate communication protocol timing have increased the demand for smaller components with the same rugged reliability as is required in watches. For applications which require absolute lowest power consumption, our Timing Crystals are available in our Low CL specifications.



Since 1979

**Excellent heat and
corrosion resistance
"Samarium-cobalt
Magnet
"DIANET"**

"DIANET", which has its origin in rotor magnets of quartz watches, has superior heat resistance and strong magnetic force even though its outside diameter is only 1 mm or less. The Sendai Unit acquired IATF 16949 Quality Management System for the automotive production industry. "DIANET" is used for a wide range of automotive products, and its advanced quality and performance are highly recognized. In addition, "DIANET" is also used in actuators of cameras for smart phones and medical devices.



Since 1988

**Stable and reliable
"Rechargeable Battery
and Capacitor"**

The rechargeable batteries supporting a wide temperature range of -40°C to 85°C are available in our lineup. They are suitable for operating very low power consumption devices, for backup power supply of clock and memory functions of a wide range of products. The capacitor will correspond to the new needs of energy harvesting devices. Capacitors are extremely useful in various applications.

Micro battery Products Lineup

Our rechargeable batteries, capacitors and silver oxide batteries are available in various sizes for broad range of applications.

Lithium Rechargeable Battery Features

- Excellent cycle characteristics
- Available in many compact sizes
- Wide Temperature Range (MS-T)
- Reflowable (MS-R, ML)

Capacitor Features

- Reflowable and high reliability
- Super small and thin size

Silver Oxide Battery Features

- Stable output voltage
- Available in many sizes of $\phi 11\text{mm}$ or less
- High capacity and High output

Lithium Rechargeable Battery

Series	Type	Size (DxH) (mm)	Nominal Voltage (V)	Maximum Use Voltage (V)	Nominal Capacity (mAh)	Internal Impedance (Ω)	Operating Temperature Range ($^{\circ}\text{C}$)	Cycle Life (100% D.O.D.) (Time)	Reflowable
MS-R	MS421R	4.8 × 2.1	3	3.3	1.5	600	-20 to +60	50	Yes
	MS621R	6.8 × 2.1	3	3.3	3.0	400	-20 to +60	50	Yes
MS	MS412FE	4.8 × 1.2	3	3.3	1.0	100	-20 to +60	100	-
	MS414GE	4.8 × 1.4	3	3.3	2.0	100	-20 to +60	50	-
	MS518SE	5.8 × 1.8	3	3.3	3.4	90	-20 to +60	100	-
	MS614SE	6.8 × 1.4	3	3.3	3.4	80	-20 to +60	100	-
	MS621FE	6.8 × 2.1	3	3.3	5.5	80	-20 to +60	100	-
	MS920SE	9.5 × 2.1	3	3.3	11.0	35	-20 to +60	100	-
MS-T	MS621T	6.8 × 2.1	3	3.3	3.0	80	-40 to +85	100	-
	MS920T	9.5 × 2.0	3	3.3	6.5	60	-40 to +85	100	-
TS	TS621E	6.8 × 2.1	1.5	3.0	2.5	50	-20 to +60	100	-
	TS920E	9.5 × 2.0	1.5	3.0	5.5	20	-20 to +60	50	-
ML	ML414H	4.8 × 1.4	3	3.1	1.0	600	-20 to +60	300*	Yes

*10% D.O.D.

Electric Double Layer Capacitor

Type	Size (LxWxH) (mm)	Maximum Use Voltage (V)	Capacitance (mF)	Internal Impedance (Ω)	Temperature Range ($^{\circ}\text{C}$)	Reflowable
CPH3225A	3.2 × 2.5 × 0.9	3.3	11.0	160	-20 to +60	Yes
CPM3225A	3.2 × 2.5 × 0.9	2.6	11.5	80	-30 to +70	Yes

Silver Oxide Battery (High Drain)

Type	Nominal Voltage (V)	Nominal Capacity (mAh)	Size (DxH) (mm)	Weight (g)
SR626W	1.55	28	6.8 × 2.60	0.39
SR721W	1.55	26	7.9 × 2.10	0.41
SR726W	1.55	34	7.9 × 2.60	0.52
SR41W	1.55	45	7.9 × 3.60	0.67
SR920W	1.55	42	9.5 × 2.05	0.60
SR927W	1.55	53, 60	9.5 × 2.70	0.75
SR1120W	1.55	53	11.6 × 2.05	0.93
SR1130W	1.55	80	11.6 × 3.05	1.29
SR43W	1.55	120	11.6 × 4.20	1.75
SR44W	1.55	160	11.6 × 5.40	2.20

Applications

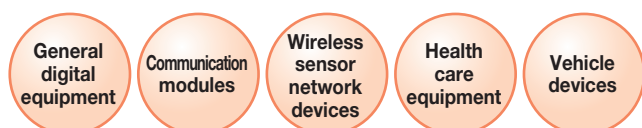

Actual sizes

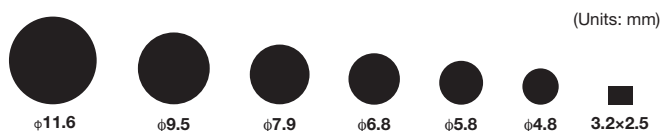

Example of a Application Circuit

Example of RTC backup circuit

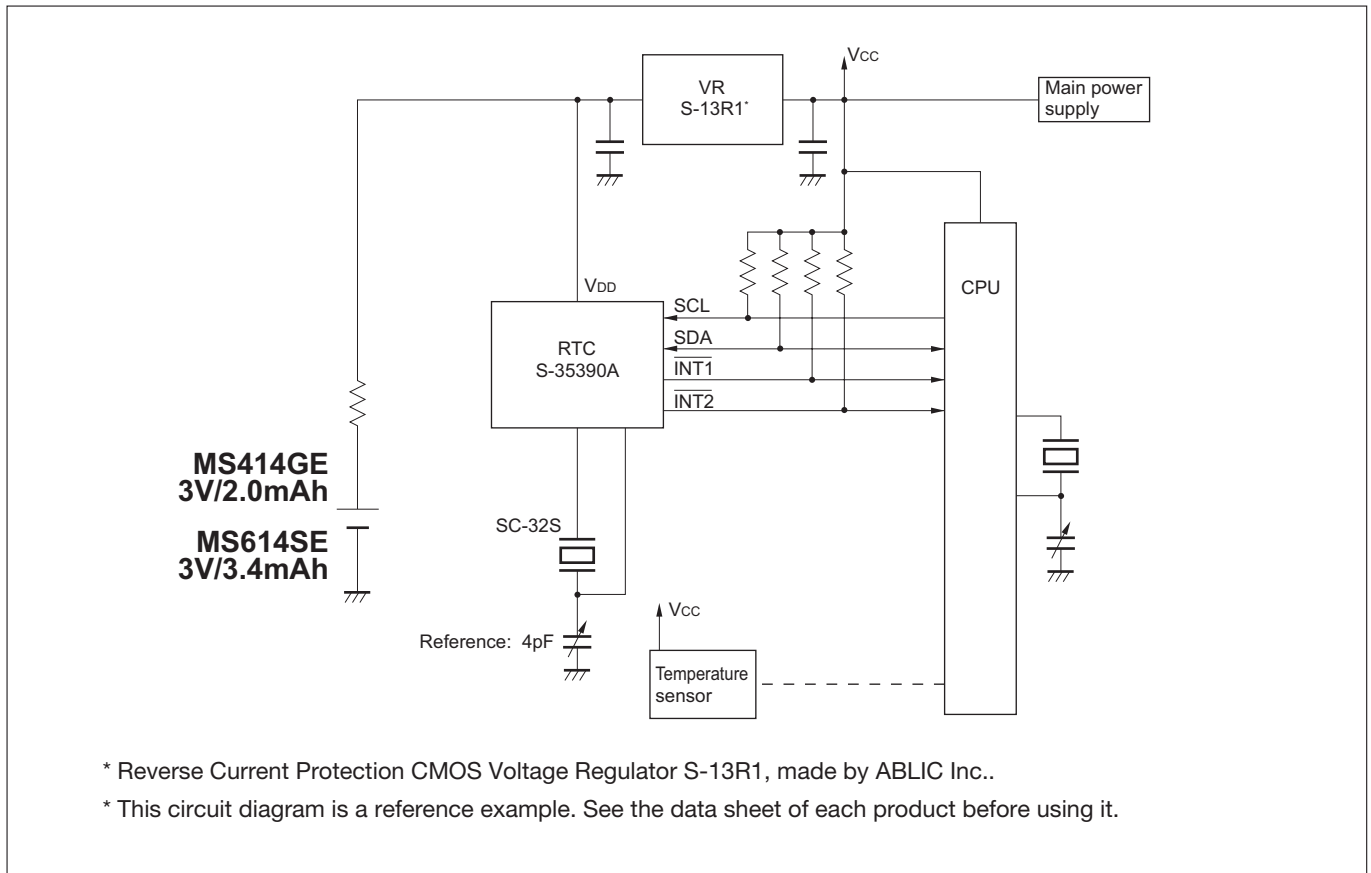

Example of RTC backup time, using MS414GE / MS614SE

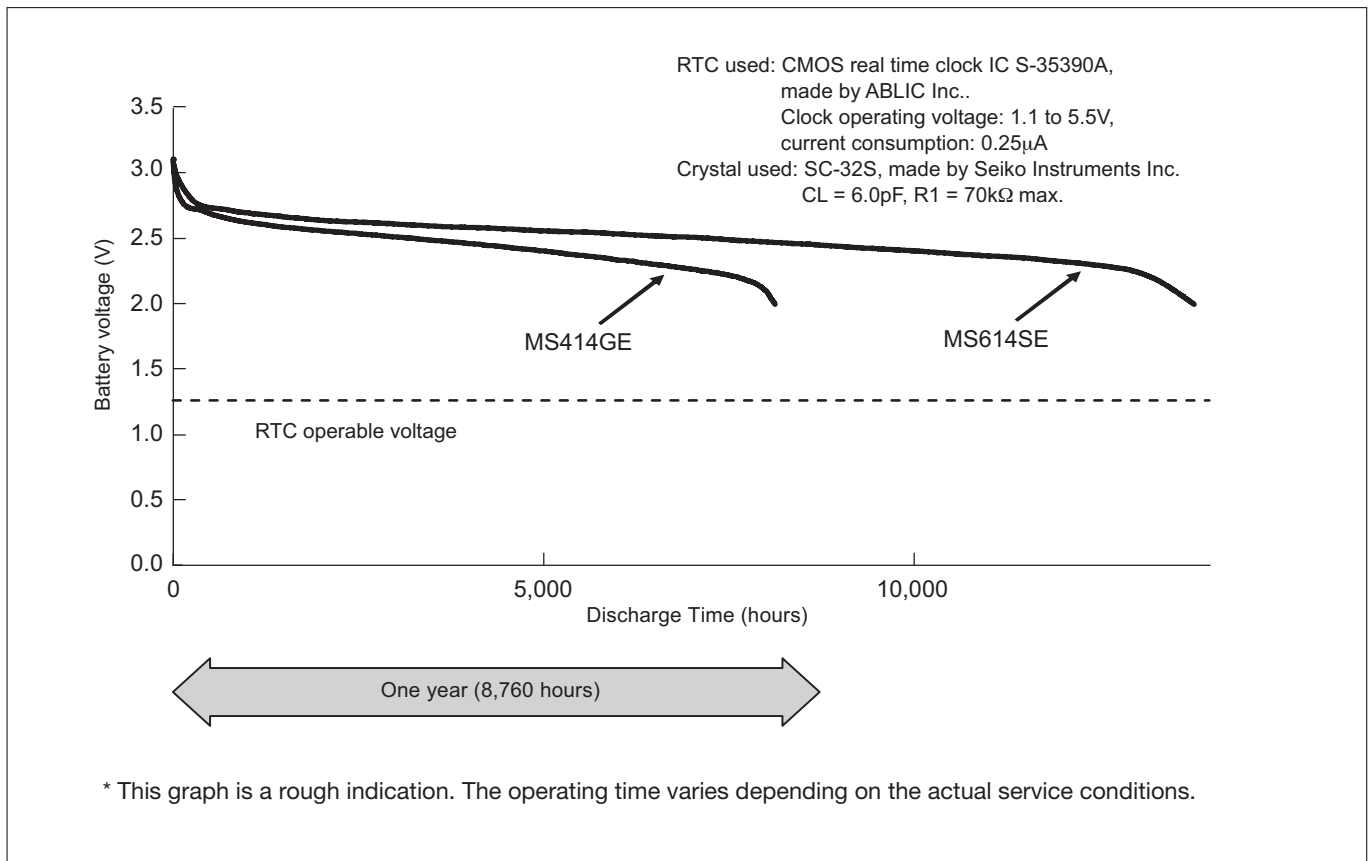

Charging circuit for MS / ML / TS Lithium Rechargeable Battery

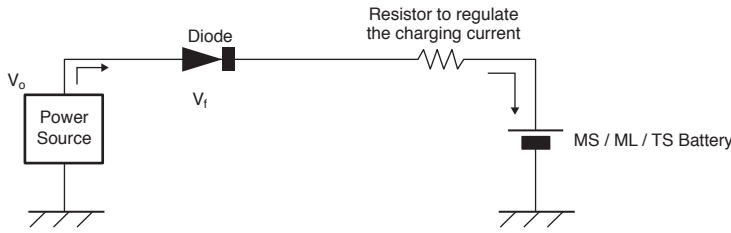

The charging voltage “Vo” must Not be higher than 3.3V (MS series) / 3.1V (ML414H) / 3.0V (TS series).

A resistor must be inserted to regulate the charging current, because our rechargeable batteries have a limit for charging current.

Please see the below table for recommended resistor values.

Those values are minimum for each battery type and “Vo” in the charging circuit.

The following table lists the recommended resistance values. For example, MS614SE and Vo 3.3V, the resistor value should be 620 ohm or more.

MS lithium rechargeable battery / ML lithium rechargeable battery

	MS412FE MS414GE	MS421R	MS518SE	MS614SE	MS621FE MS621T MS621R	MS920SE MS920T	ML414H
Vo (V)	Resistor (ohm)	Resistor (ohm)	Resistor (ohm)	Resistor (ohm)	Resistor (ohm)	Resistor (ohm)	Resistor (ohm)
3.3	2,000	3,000	1,500	620	620	620	prohibited
3.1	1,600	3,000	820	330	330	330	3,000

TS lithium rechargeable battery

	TS621E	TS920E
Vo (V)	Resistor (ohm)	Resistor (ohm)
3.0	10,000	12,000
2.3	6,800	8,200
1.6	3,000	4,700

Discharge capacity depends on charging voltage.

Lower charging voltage may cause lower discharge capacity.

Please see Charge Voltage Characteristics data in respective battery pages.

Charging circuit for CPH / CPM capacitor

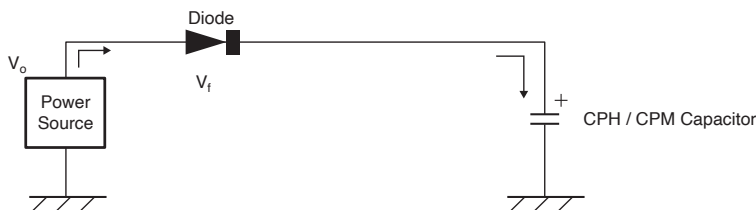

You do not need to insert a resistor to regulate charging current.

Our CPH / CPM capacitor do not have a limit for charging current.

The charging voltage “Vo” must Not be higher than 3.3V (CPH3225A) / 2.6V (CPM3225A).

Reflowable

MS621R / MS421R

New products “MS-R series” are large capacity small size coin battery that can be mounted by reflow soldering.

In addition to being reflowable, they offer the unique features of the conventional MS rechargeable batteries such as high-voltage (3.3V), large-capacity, long cycle life, and excellent over discharge characteristics.



FEATURES

- Reflowable
- Higher voltage, 3.3V (Compared with our ML414H)
- Excellent cycle characteristics (Compared with our ML414H)
- Battery is not applied to RoHS Directives. Our battery products do not contain any substances restricted by RoHS Directive.
- Approved by UL (Underwriters Laboratories Inc.)
UL File No. MH15628

APPLICATIONS

Backup power for Real Time Clock, or memory.
E.g. Digital Camera, Action Camera,
GPS equipment, Event Data Recorder,
Handy Terminal, PC, Smart phone.

Type	Nominal Voltage (V)	Charge Voltage (Standard Charge Voltage) (V)	Nominal Capacity *1 (mAh)	Internal Impedance *2 (Ω)	Operating Temperature Range	Cycle Life (Time)		Size (mm)		Weight (g)
						100%	20%	Diameter	Height	
MS421R	3	2.9 to 3.3(3.1)	1.5	600	-20°C to +60°C	50	500	4.8	2.1	0.11
MS621R	3	2.8 to 3.3(3.1)	3.0	400	-20°C to +60°C	50	500	6.8	2.1	0.24

*1. Nominal capacity: Typical value of discharge capacity between 3.1V and 2.0V.

*2. A constant voltage charge is recommended, but due to a limit in charge current, it is necessary to insert a resistor to regulate the charge current.

Please see Page 7 for resistor value. Contact us for further details.

If a constant current charge is required, contact us for more information.

Please see Page 21 for Reflow profile example.

CHARACTERISTICS

Charge/discharge characteristics

MS621R

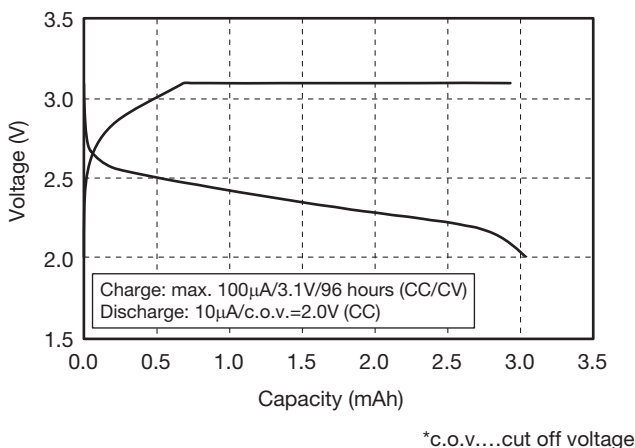

DIMENSIONS

MS621R II27E

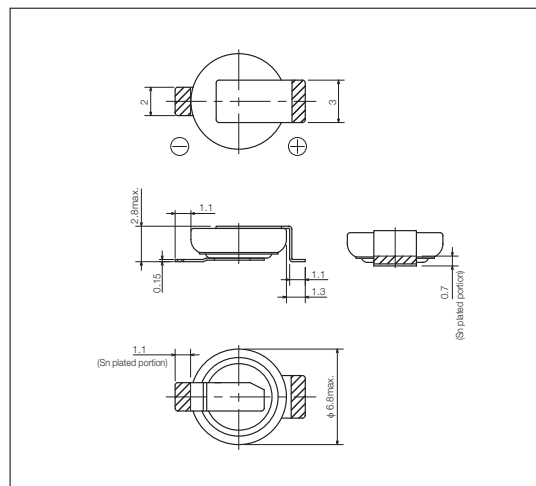

- Units: mm
- The shaded parts are tin plated (Sn: 100%).

CHARACTERISTICS

Charge-Discharge Cycle Characteristics

MS421R

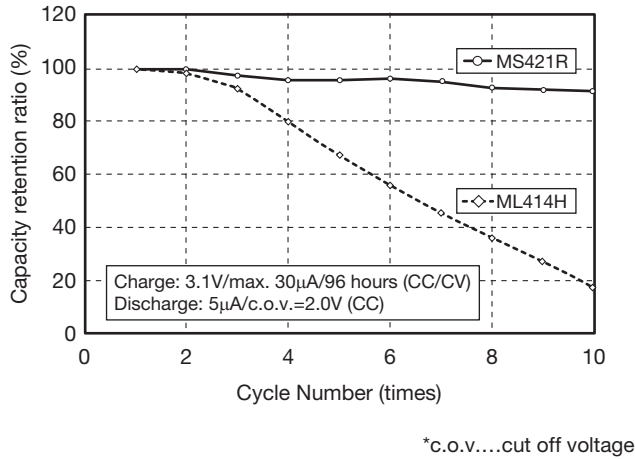

DIMENSIONS

MS421R IV03E

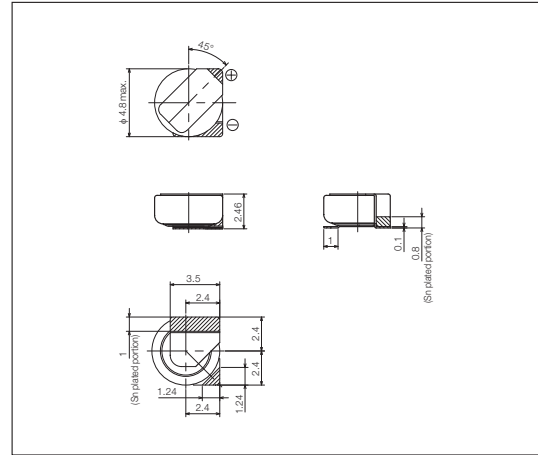

- Units: mm
- The shaded parts are tin plated (Sn: 100%).

ML Lithium Rechargeable Battery

SII ML Series Reflowable

Reflowable

ML414H

“ML414H” is a thin and small size coin battery that can be mounted by reflow soldering.



FEATURES

- Operating temperature range: -20°C to $+60^{\circ}\text{C}$
Consult us for using the battery at a temperature beyond the above temperature range.
- Battery is not applied to RoHS Directives. Our battery products do not contain any substances restricted by RoHS Directive.
- Approved by UL (Underwriters Laboratories Inc.)
UL File No. MH15628

Type	Nominal Voltage (V)	Charge Voltage ^{*3} (V)	Nominal Capacity (Voltage Range V) (mAh)	Internal Impedance ^{*1} (Ω)	Standard Discharge Current (mA)	Cycle Life ^{*2} (Time)	Diameter (mm)	Height (mm)	Weight (g)
ML414H	3	2.7 to 3.1	1.0 (3.1 to 2.0)	600	0.005	300 (10% D.O.D.)	4.8	1.4	0.07

*1. Value measured using an AC (Alternating Current) method in the fully charged state.

*2. Counts of charge and discharge repetition that maintains about 50% of the minimum guaranteed capacity

*3. A constant voltage charge is recommended, but due to a limit in the charge current, it is necessary to insert a resistor to regulate the charge current.

Please see Page 7 for resistor value. Contact us for further details. If a constant current charge is required, please contact us for more information.

CAUTION

Max. charging voltage of ML414H is 3.1V.

Please see Page 21 for Reflow profile example.

Non-Reflowable

MS412FE / MS414GE / MS518SE / MS614SE / MS621FE / MS920SE

MS (Manganese Silicon) lithium rechargeable batteries, developed by SII, use silicon oxide as the anode and a lithium manganese composite oxide as the cathode. As a result, they offer long cycle life and highly stable overdischarge characteristics.

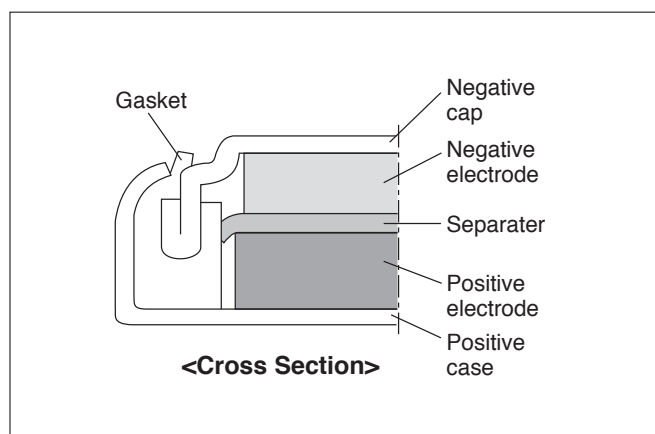

FEATURES

- Large discharge capacity :
For high operational voltage range of 3.3V to 2.0V.
- Long cycle life :
Cycle life of over 100 cycles (over 50 cycles for MS414GE) under charge/discharge conditions of 3.1V to 2.0V (D.O.D.100%).
- Excellent overdischarge characteristics :
Continued stable capacity characteristics even after the battery is overdischarged down to 0.0V.
- Operating temperature range : -20°C to $+60^{\circ}\text{C}$
Consult us for using the battery at a temperature beyond the above temperature range.
- Battery is not applied to RoHS Directives. Our battery products do not contain any substances restricted by RoHS Directive.
- Approved by UL (Underwriters Laboratories Inc.)
UL File No. MH15628

APPLICATIONS

Backup power for Real Time Clock, or memory.
E.g. Digital Camera, Action Camera,
GPS equipment, Event Data Recorder,
Handy Terminal, PC, Smart phone.

Type	Nominal Voltage (V)	Charge Voltage (Standard Charge Voltage)*6 (V)	Nominal Capacity (mAh)*1	Internal Impedance (Ω)*2	Standard Discharge Current (mA)	Maximum Discharge Current (Continuous) (mA)*3	Cycle Life (Time)*4		Size (mm)		Weight (g)
							100%*5 D.O.D. (Depth of Discharge)	20%*5 D.O.D. (Depth of Discharge)	Diameter	Height	
MS412FE	3	2.8 to 3.3 (3.1)	1.0	100	0.010	0.10	100	1000	4.8	1.2	0.07
MS414GE	3	2.8 to 3.3 (3.1)	2.0	100	0.010	0.05	50	500	4.8	1.4	0.08
MS518SE	3	2.8 to 3.3 (3.1)	3.4	90	0.010	0.15	100	1000	5.8	1.8	0.13
MS614SE	3	2.8 to 3.3 (3.1)	3.4	80	0.015	0.25	100	1000	6.8	1.4	0.17
MS621FE	3	2.8 to 3.3 (3.1)	5.5	80	0.015	0.25	100	1000	6.8	2.1	0.23
MS920SE	3	2.8 to 3.3 (3.1)	11.0	35	0.050	0.80	100	1000	9.5	2.1	0.47

*1. Nominal capacity: Typical value of discharge capacity between 3.1V and 2.0V

*2. Internal impedance is measured using an AC (Alternating Current) method at the fully charged state.

*3. Maximum discharge current indicates the value of a current for approximately 50% of the nominal capacity.

*4. Cycle Life indicates the times charge/discharge is repeated for approximately 50% of the capacity values in the specification sheet.

*5. 100% and 20% are based on nominal capacity.

*6. A constant voltage charge is recommended, but due to a limit in charge current, it is necessary to insert a resistor to regulate the charge current.

Please see Page 7 for resistor value. Contact us for further details.

If a constant current charge is required, contact us for more information.

CAUTION

MS Lithium Rechargeable Batteries are not reflowable. Please mount them on PCB by hand soldering.

CHARACTERISTICS

DISCHARGE (CHARGE VOLTAGE DEPENDENCE)

MS412FE

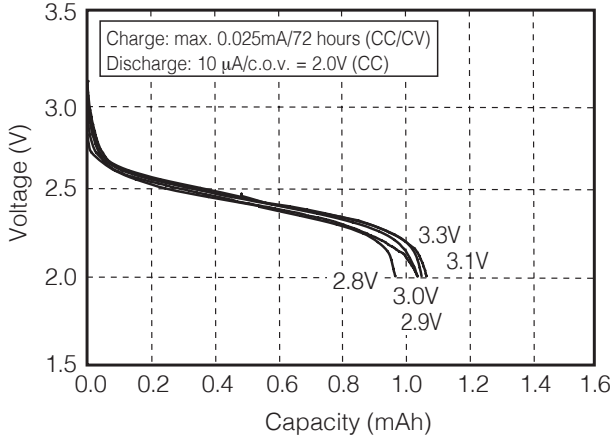

MS414GE

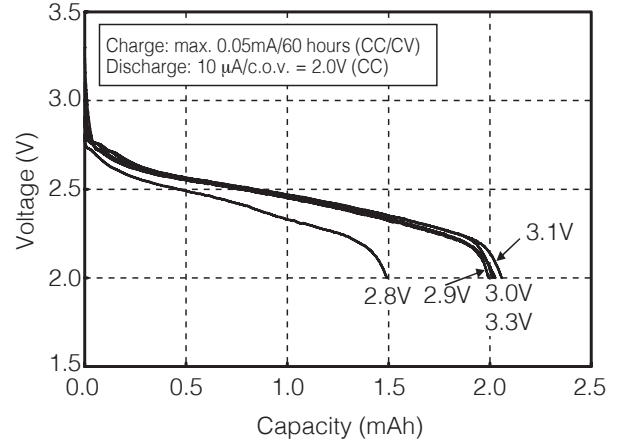

MS518SE

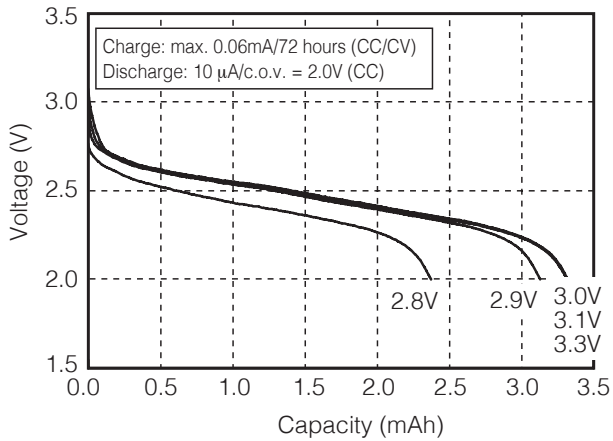

MS614SE

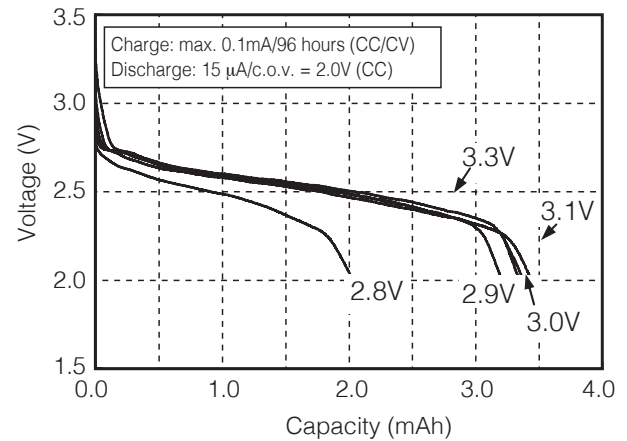

MS621FE

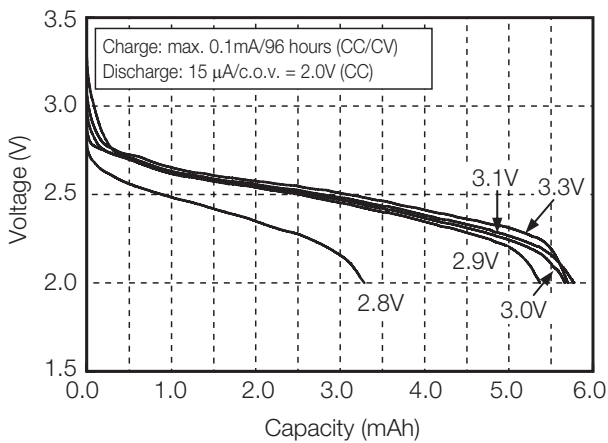

MS920SE

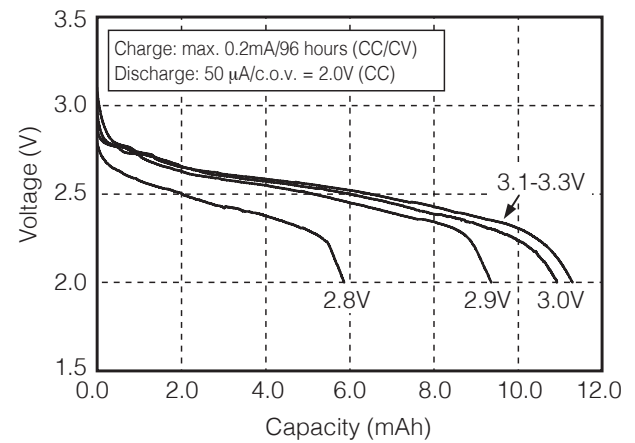

*c.o.v....cut off voltage

CHARACTERISTICS

MS621FE

Charge/discharge characteristics

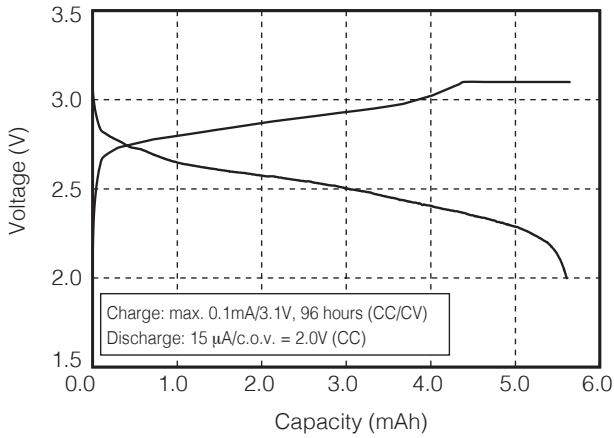

Discharge Current characteristics

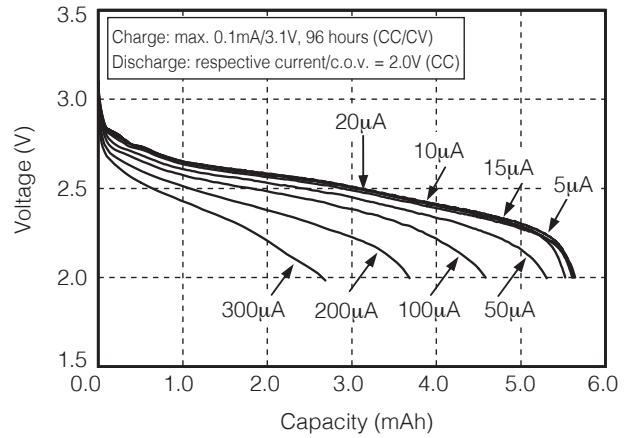

Overdischarge Characteristics

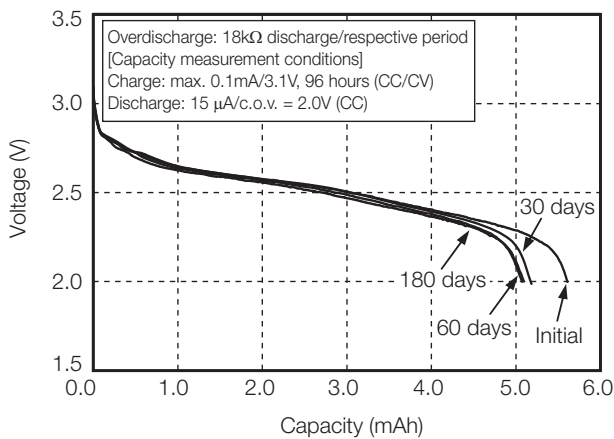

Discharge Temperature Characteristics

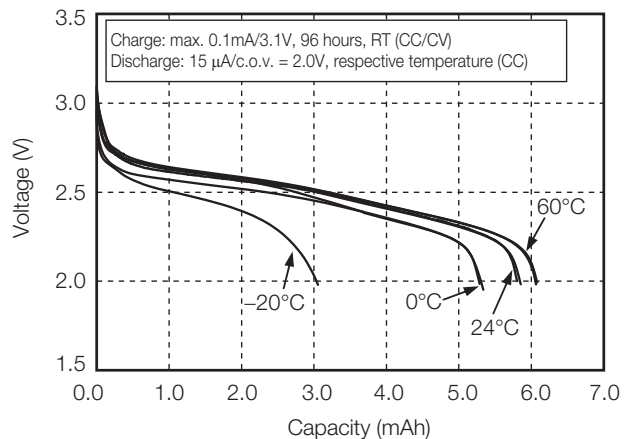

High Temperature (60°C) Storage Characteristics

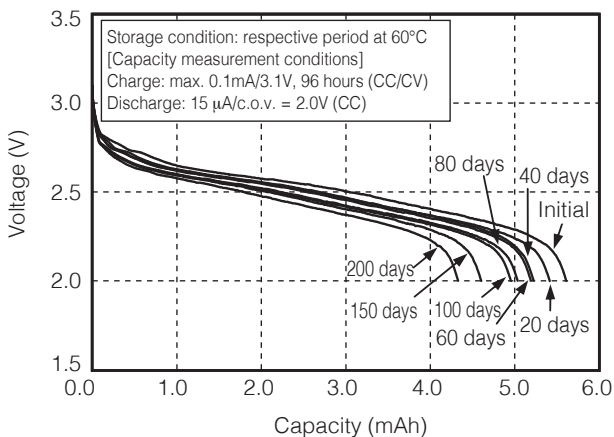

Floating Characteristics (60°C, applied voltage 3.1V)

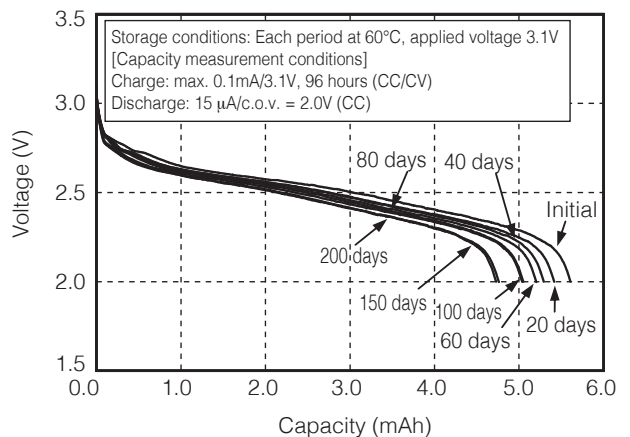

*c.o.v....cut off voltage

DIMENSIONS

MS412FE FL26E

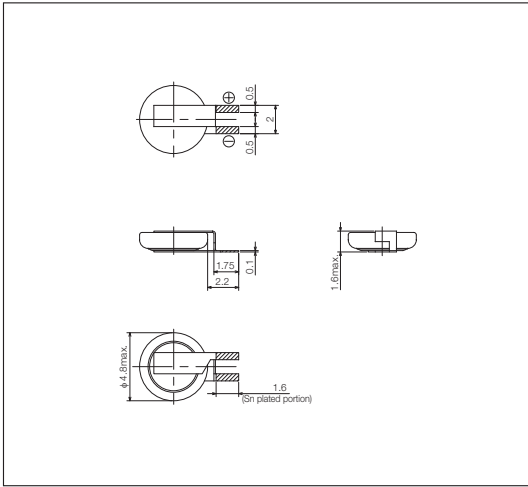

MS412FE

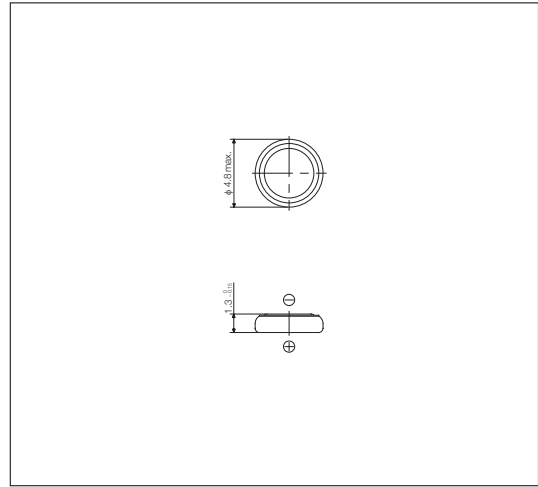

MS414GE FL26E

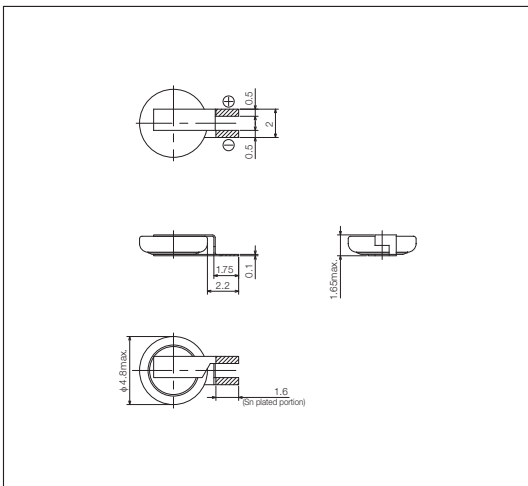

MS414GE

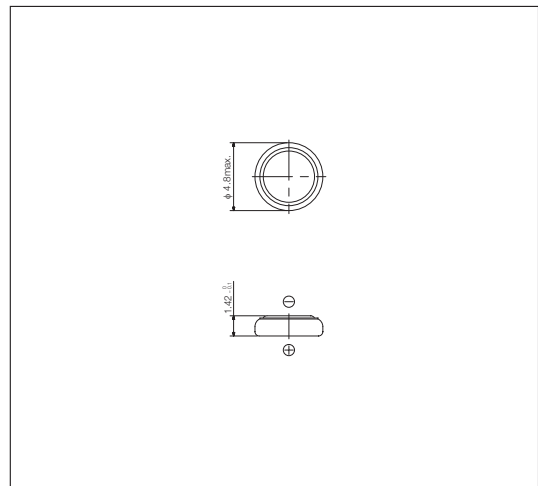

MS518SE FL35E

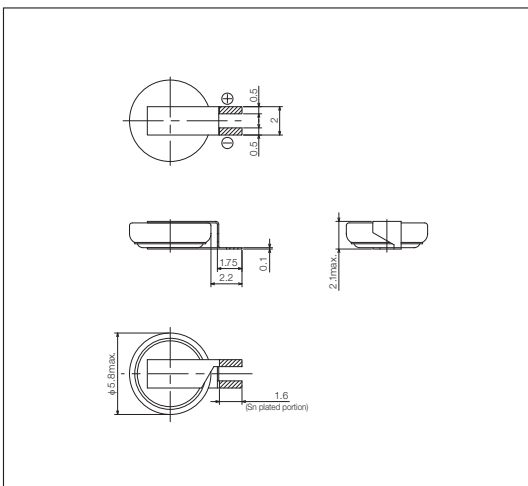

MS518SE

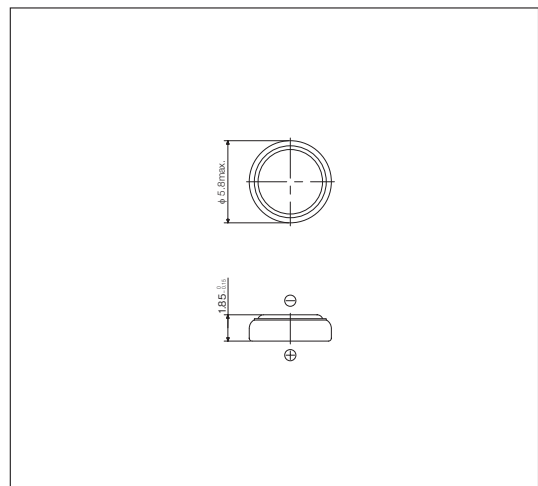

- Units: mm

- The shaded parts are tin plated (Sn: 100%).

DIMENSIONS

MS614SE FL28E

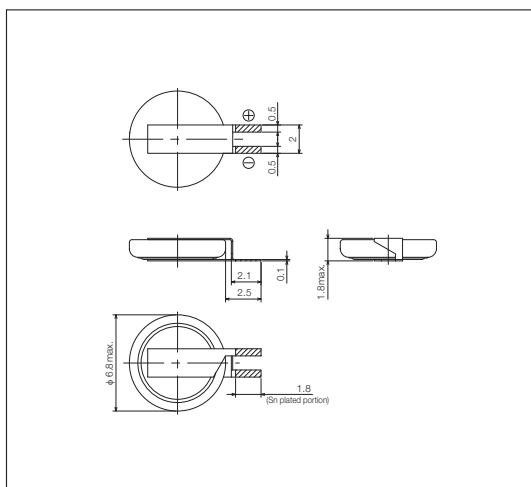

MS614SE

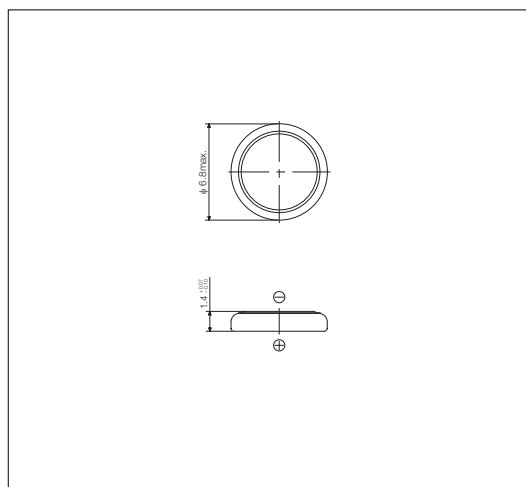

MS621FE FL11E

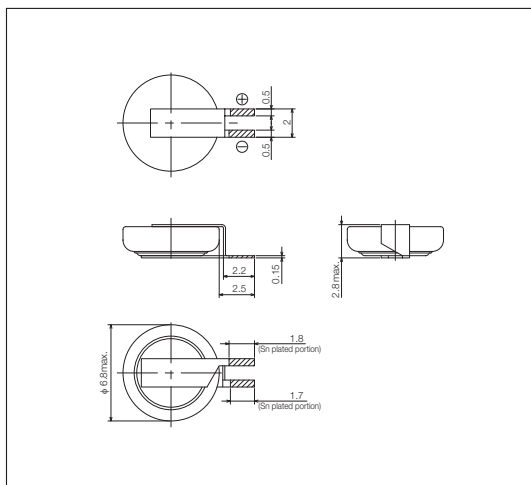

MS621FE

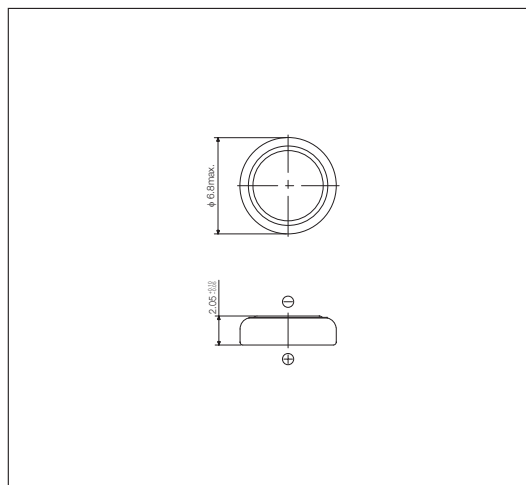

MS920SE FL27E

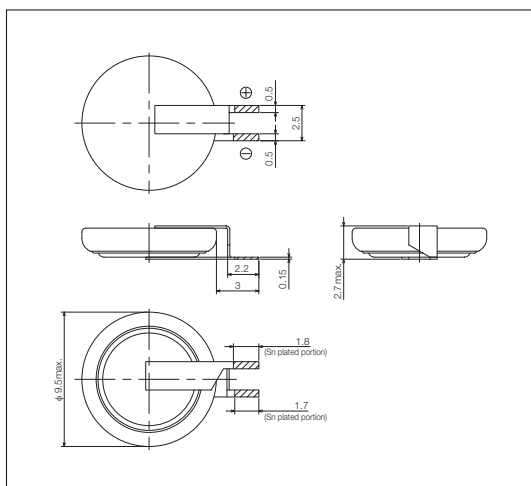

MS920SE

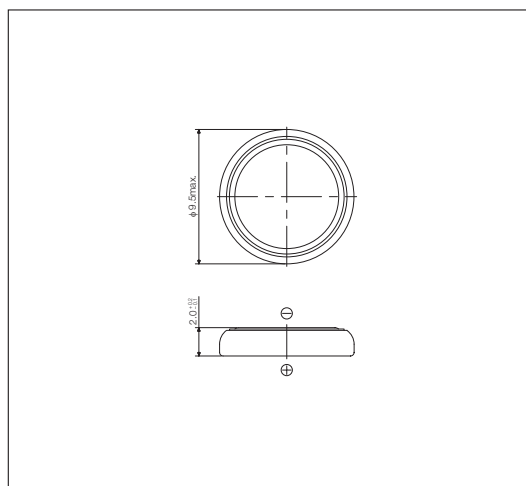

- Units: mm

- The shaded parts are tin plated (Sn: 100%).

DIMENSIONS

MS621T FL11E

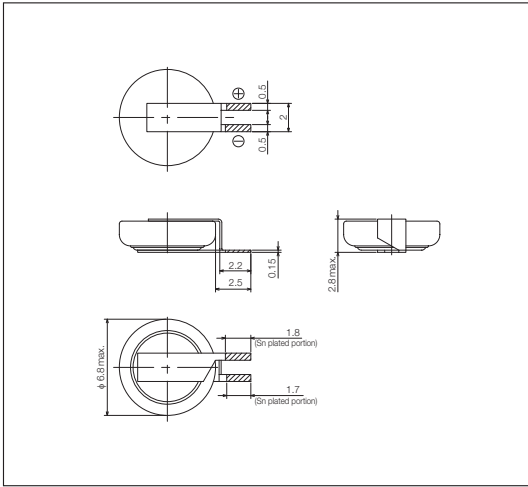

MS621T

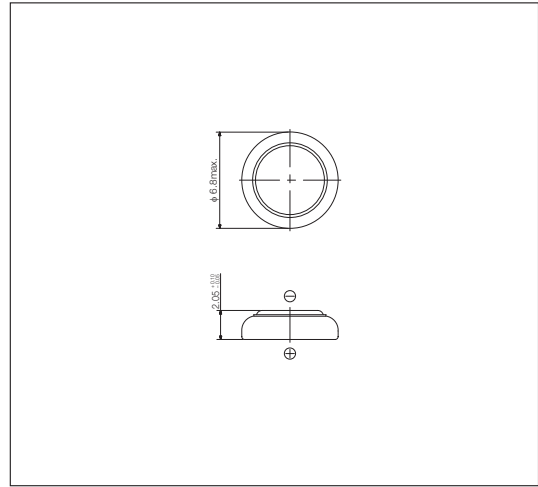

MS920T FL27E

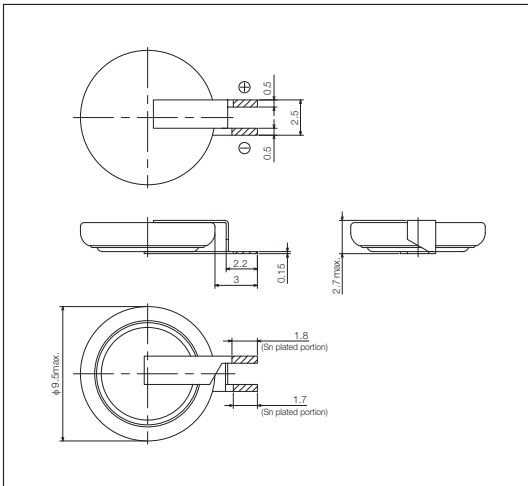

MS920T

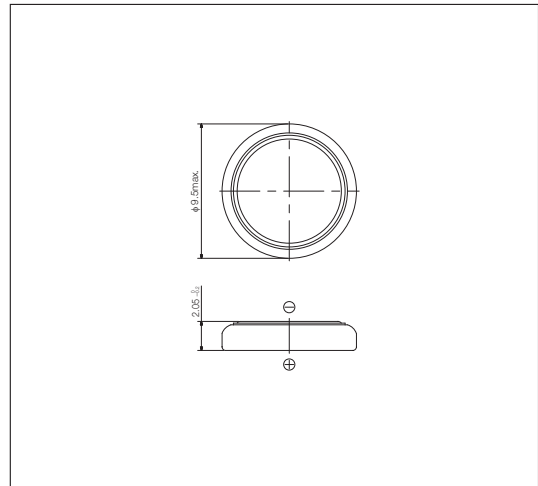

- Units: mm

- The shaded parts are tin plated (Sn: 100%).

Non-Reflowable

MS621T / MS920T

“MS621T” and “MS920T” have improved both higher and lower temperature characteristics while leaving features of the conventional MS rechargeable batteries. They offers wider temperature range from -40°C to +85°C.

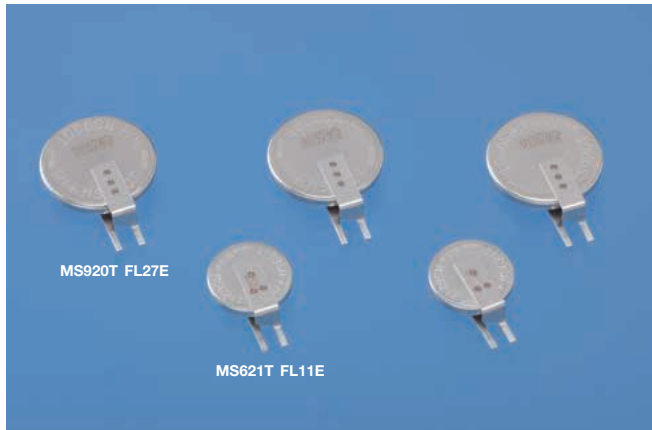

FEATURES

- Operation over a wide temperature range:
Operating temperature range : -40°C to +85°C
- High reliability : At least 90% of retention capacity after exposure to 85°C for 100 days.
- Long cycle life : 100 cycles (D.O.D.100%)
- Battery is not applied to RoHS Directives. Our battery products do not contain any substances restricted by RoHS Directive.
- Approved by UL (Underwriters Laboratories Inc.)
UL File No. MH15628

APPLICATIONS

Backup power for Real Time Clock, or memory.
E.g. Automotive equipment, Security cameras, electronic power, gas and water meters, electronic devices where PCB temperature increases.

Type	Nominal Voltage (V)	Charge Voltage (Standard Charge Voltage) (V)	Nominal Capacity *1 (mAh)	Internal Impedance *2 (Ω)	Operating Temperature Range	Cycle Life (Time)		Size (mm)		Weight (g)
						100%	20%	Diameter	Height	
MS621T	3	2.8 to 3.3(3.1)	3.0	80	-40°C to +85°C	100	1000	6.8	2.1	0.23
MS920T	3	2.8 to 3.3(3.1)	6.5	60	-40°C to +85°C	100	1000	9.5	2.0	0.45

*1. Nominal capacity: Typical value of discharge capacity between 3.1V and 2.0V.
*2. A constant voltage charge is recommended, but due to a limit in charge current, it is necessary to insert a resistor to regulate the charge current. Please see Page 7 for resistor value. Contact us for further details.
If a constant current charge is required, contact us for more information.

CAUTION
MS Lithium Rechargeable Batteries are not reflowable. Please mount them on PCB by hand soldering.

CHARACTERISTICS

Charge Voltage Characteristics

MS621T

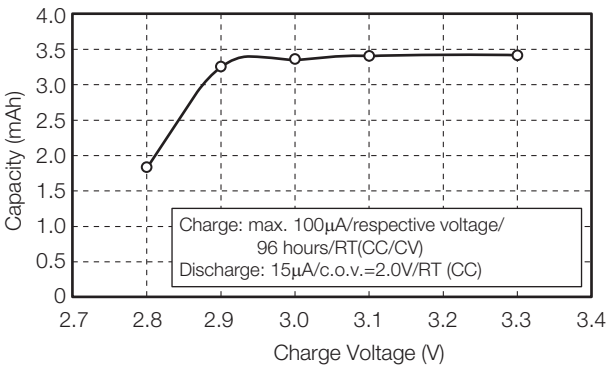

MS920T

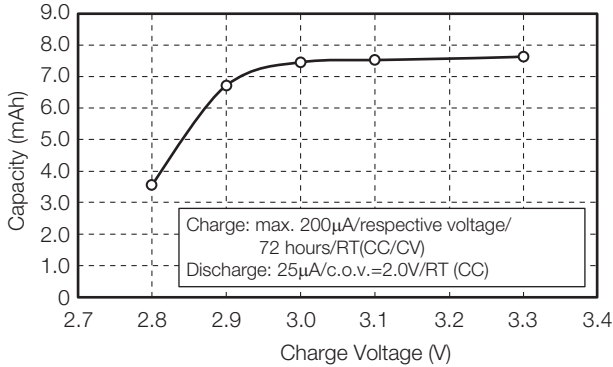

CHARACTERISTICS

Discharge characteristics (-40°C capacity)

MS621T

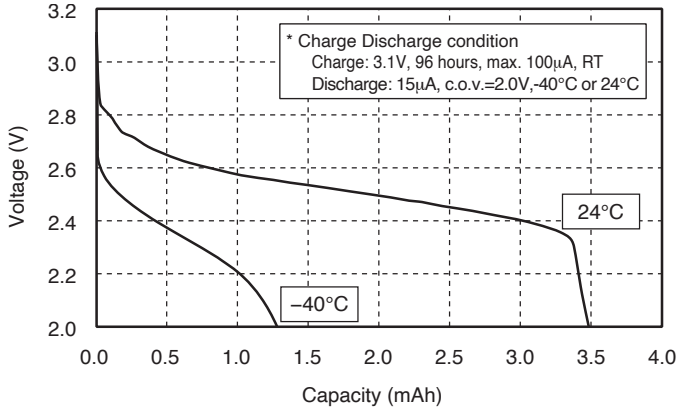

MS920T

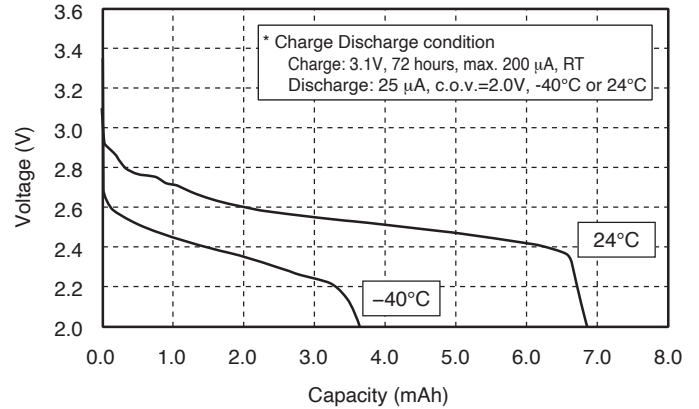

High temperature characteristics (85°C storage)

Storage period - Capacity retention ratio

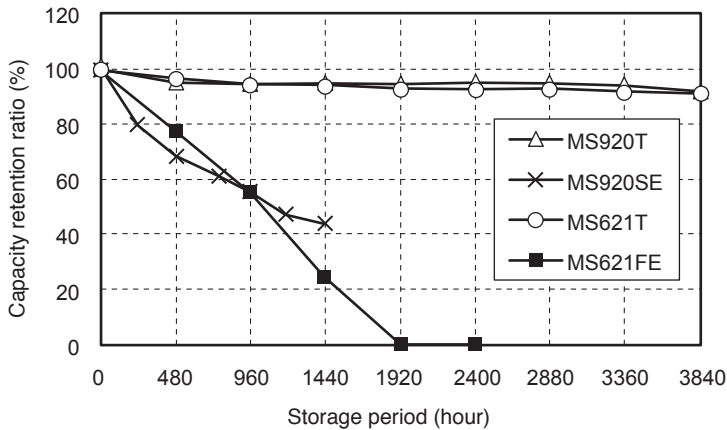

MS-T series' capacity retention ratio after High temperature storage were greatly improved.

* 85°C use of Conventional MS series is not guaranteed.

* Charge Discharge condition
MS920T
Charge: 3.1V, 72 hours, max. 200 μ A, RT
Discharge: 25 μ A, c.o.v.=2.0V, RT
MS621T
Charge: 3.1V, 96 hours, max. 100 μ A, RT
Discharge: 15 μ A, c.o.v.=2.0V, RT

*c.o.v.....cut off voltage

Charge Characteristics (MS920T)

Charge time - Discharge capacity

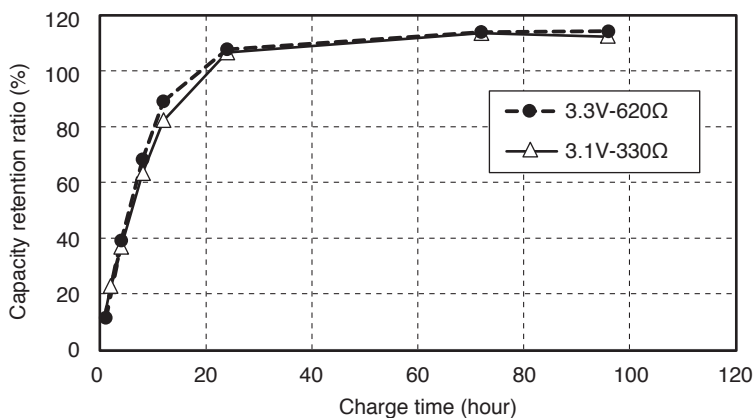

Both the MS621T and MS920T can reach 80% of capacity after 12 hours of charging.

*MS920T: Calculated given a 100% charge of 6.5 mAh nominal capacity.

* Charge condition
3.3V,620 Ω
3.1V,330 Ω

*c.o.v.....cut off voltage

Non-Reflowable

TS621E / TS920E

TS lithium rechargeable batteries are high capacity 1.5V type non-reflowable rechargeable batteries that provide sufficient discharge capacity with a charge voltage of less than 2.0V.



FEATURES

- Low-voltage rechargeable
- High capacity
- Long cycle life: at least 1000 cycles (20% D.O.D.)
- Battery is not applied to RoHS Directives. Our battery products do not contain any substances restricted by RoHS Directive.
- Approved by UL (Underwriters Laboratories Inc.)
UL File No. MH15628 (TS621E only)

APPLICATIONS

- Solar Watch (as main battery)
- Small mobile equipment (backup power supply for Real Time Clock)
E.g. Digital Camera, Action Camera, GPS equipment, Event Data Recorder, Handy Terminal, PC, Smart phone.

Type	Nominal Voltage (V)	Charge Voltage ⁴ (V)	Nominal Capacity (Voltage Range V) ¹ (mAh)	Internal Impedance ² (Ω)	Standard Discharge Current (mA)	Cycle Life ³ (Time)	Diameter (mm)	Height (mm)	Weight (g)
TS621E	1.5	1.5 to 3.0	1.3 (1.5 to 1.0) 2.5 (2.3 to 1.0)	50	0.025	1000 (20% D.O.D.) 100 (100% D.O.D.)	6.8	2.1	0.23
TS920E	1.5	1.6 to 3.0	5.5 (2.3 to 1.0)	20	0.05	1000 (20% D.O.D.) 50 (100% D.O.D.)	9.5	2.0	0.46

*1. The discharge capacity of each voltage range (Room Temperature).

*2. Value measured using an AC (Alternating Current) method in the fully charged state.

*3. Counts of charge and discharge repetition that maintains about 50% of the minimum guaranteed capacity

*4. A constant voltage charge is recommended, but due to a limit in the charge current, it is necessary to insert a resistor to regulate the charge current.
Please see Page 7 for resistor value. Contact us for further details.

If a constant current charge is required, please contact us for more information.

CAUTION

TS Lithium Rechargeable Batteries are not reflowable. Please mount them on PCB by hand soldering.

CHARACTERISTICS

Charge/discharge characteristics

TS621E

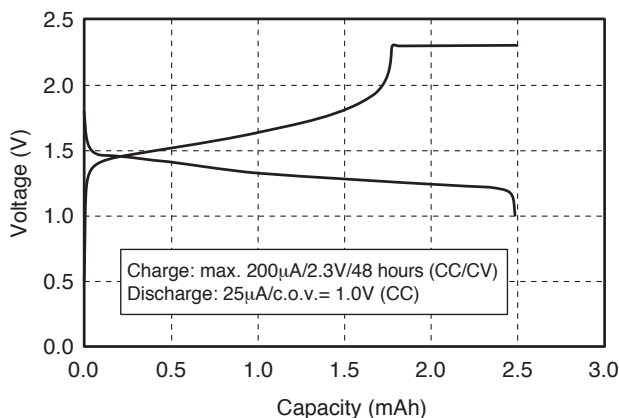

TS920E

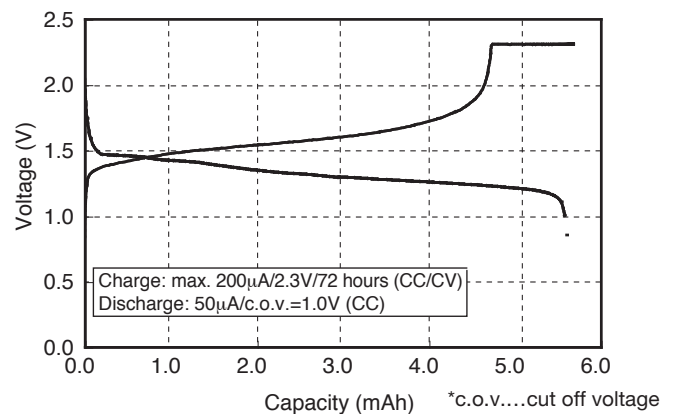

CHARACTERISTICS

Charge Voltage Characteristics

TS621E

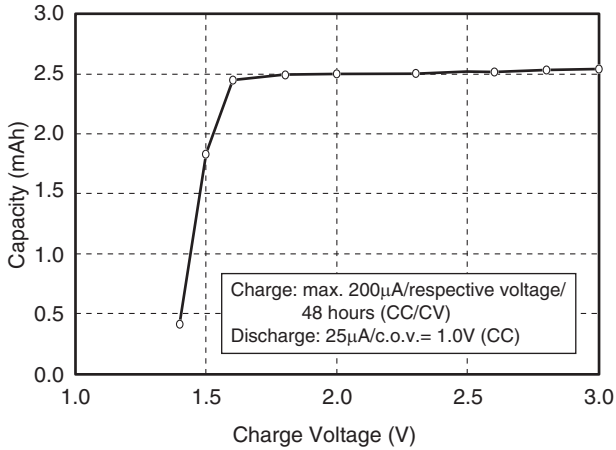

TS920E

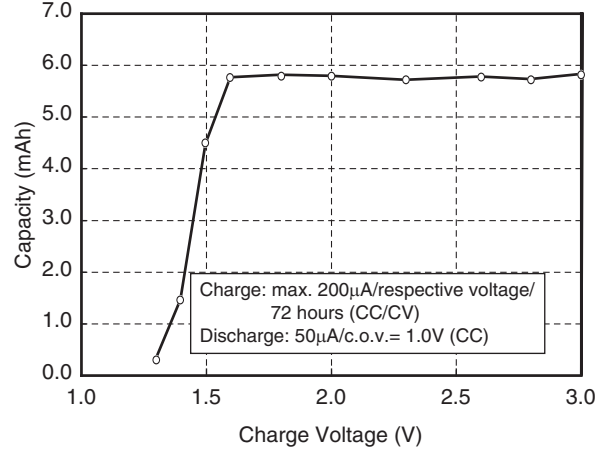

High Temperature Storage Characteristics

TS920E

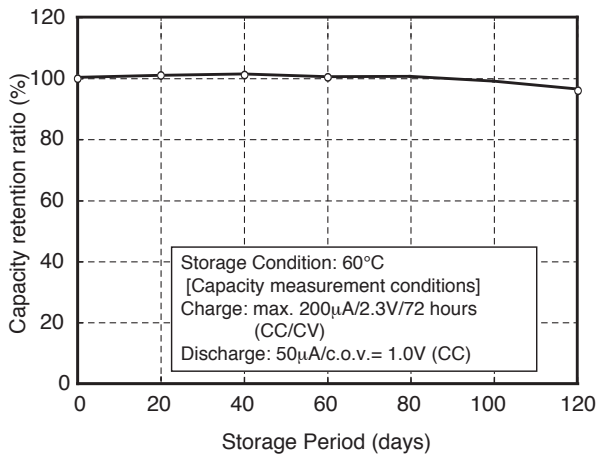

Float-Charge Characteristics

TS920E

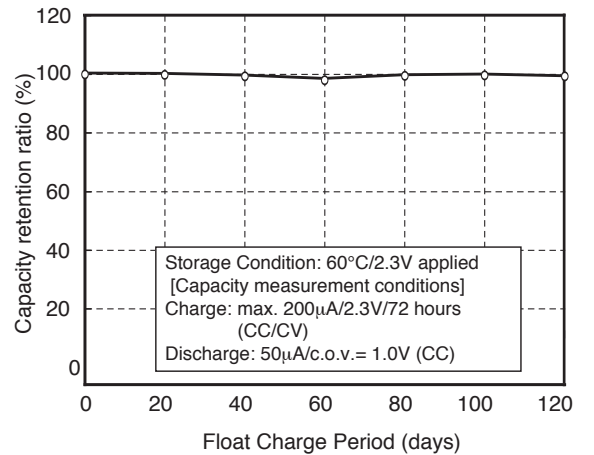

*c.o.v.....cut off voltage

DIMENSIONS

TS621E FL11E

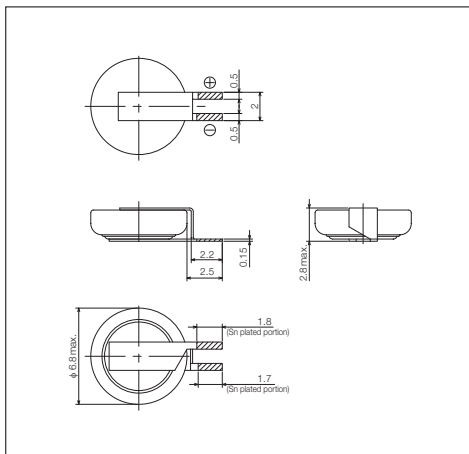

- Units: mm
- The shaded parts are tin plated (Sn: 100%).

TS920E FL27E

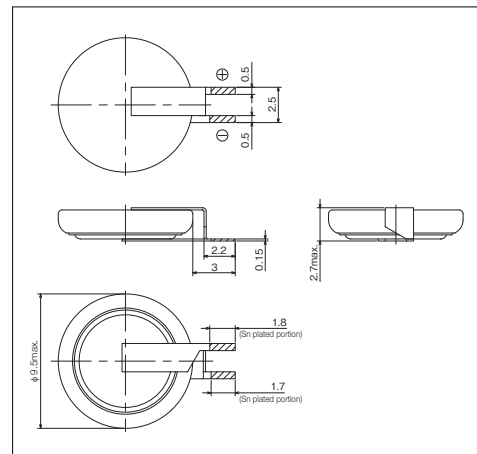

Reflowable

CPH3225A / CPM3225A

The thin (less than 1 mm) and small (3.2 mm × 2.5 mm) chip-type electric double layer capacitors have unique ceramic packaging with superior air-tightness. It assures superior leakage and humidity resistance.

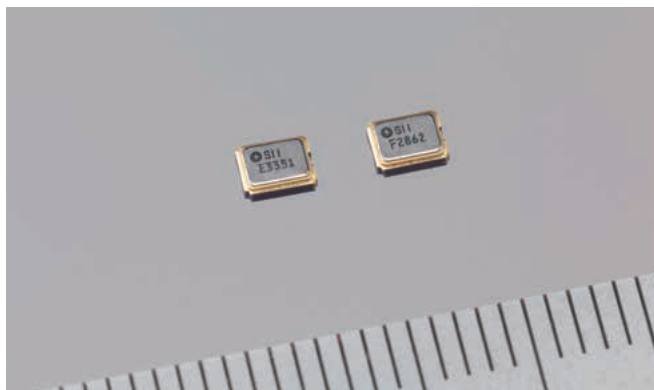

FEATURES

- Excellent leakage resistance and humidity resistance
- Long life span, high reliability
Superior air-tight ceramic package reduces storage deterioration in high temperature / high humidity environments, assuring long term reliability.
- Small leak current
CP capacitor allows sufficient charging with several micro watts of energy harvesting power source.
- Long cycle Life:
At least 10,000 times of charge/discharge.
- Simple Charging circuit (constant voltage charging)
- RoHS Compliant

3.3V type

Type	Maximum Use Voltage (V)	Capacitance (mF)	Internal Impedance (ESR) * (Ω)	Size (LxWxH) (mm)	Operating Temperature Range	Weight (g)
CPH3225A	3.3	11.0	160	3.2×2.5×0.9	-20°C to +60°C	0.024

2.6V type

Type	Maximum Use Voltage (V)	Capacitance (mF)	Internal Impedance (ESR) * (Ω)	Size (LxWxH) (mm)	Operating Temperature Range	Weight (g)
CPM3225A	2.6	11.5	80	3.2×2.5×0.9	-30°C to +70°C	0.024

*. Value measured using AC (Alternating Current) method at the discharged state.

CAUTION

1. Prohibition ripple charging

A ripple (high frequency fluctuation of voltage) in the charge voltage extremely lowers the capacitor performance.
Be sure to charge capacitors with a stable voltage.

2. Charge voltage

The age deterioration of the capacitor depends on the charge voltage.
The age deterioration is accelerated as charge voltage goes higher.

3. Usage environment

Aging degradation of the capacitor varies depending on the usage environment (temperature and humidity).
Contact us for further details.

APPLICATIONS

- Power backup for Real Time Clock or memory
- Power assist for main battery
- Electric storage device for energy harvesting
- Peak load leveling of primary battery
E.g. Handy terminals, Payment terminals, Wireless sensor network devices, NFC-enabled mobile devices, Battery powered medical devices, etc.

CHARACTERISTICS

Discharge Characteristics

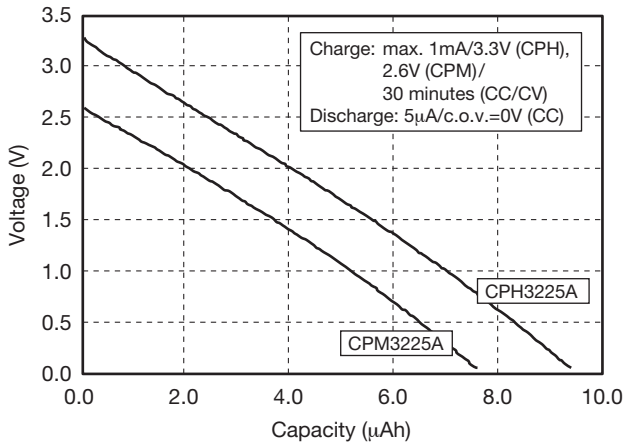

Charge Characteristics

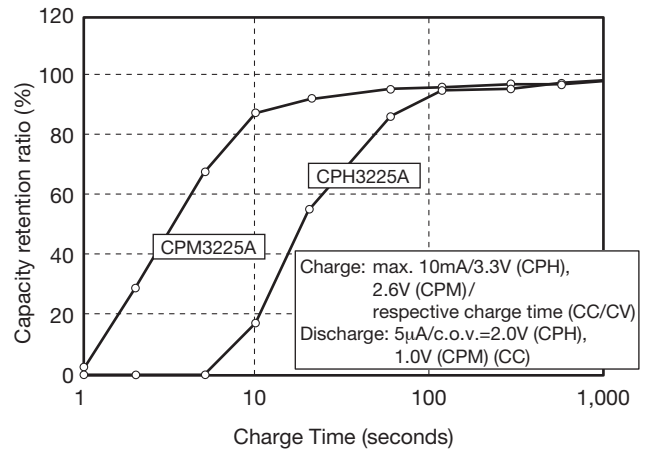

REFLOW SOLDERING CONDITIONS

Reflow Profile Example

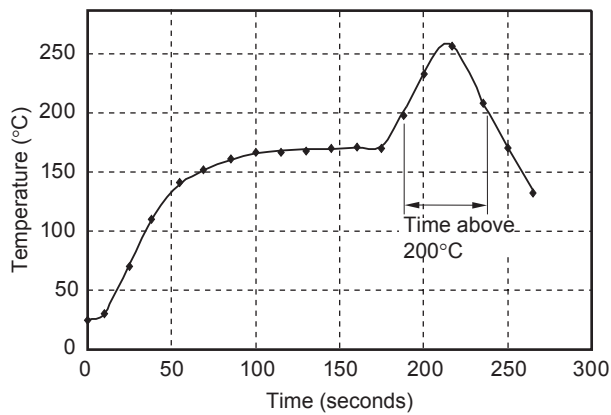

The times of repeated reflow soldering must be two times or less.
The Temperature must be measured at top of the cell.

DIMENSIONS

CPH3225A / CPM3225A

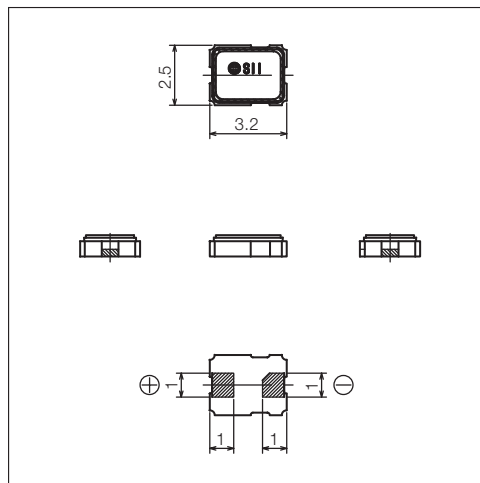

- Units: mm

Mercury Free Silver Oxide Battery : SEIZAIKEN

Non-Reflowable

SEIZAIKEN, Mercury Free Silver Oxide Batteries by SII, has grown with the history of quartz watches. Silver Oxide Batteries have high density of energy per volume and are able to supply stable voltage for a long time. SEIZAIKEN Batteries are suitable to power BLE(Bluetooth Low Energy), wearable devices, and information devices.



FEATURES

- Stable power voltage
- Large energy density
- Able to discharge mA level of pulse current
- Lineup of small diameter (11.6mm and less)

APPLICATIONS

Devices that require high discharge pulsing.

Type	Nominal Voltage (V)	Nominal Capacity (mAh)	Discharge Level	Dimensions (mm)		Weight (g)
				Diameter	Height	
SR**SW	1.55	5.5 to 160	Low current	4.8 to 11.6	1.25 to 5.40	0.11 to 2.20
SR**W	1.55	26 to 160	High current	6.8 to 11.6	2.05 to 5.40	0.39 to 2.20

CHARACTERISTICS

Discharge Characteristics

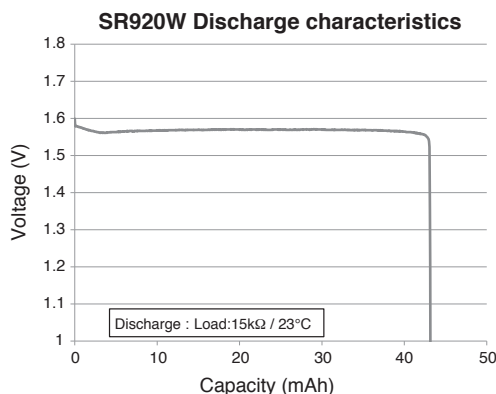

SEIZAIKEN is our trademark for silver oxide battery globally acknowledged in the quartz watch market.

Low Drain Battery Lineup

Type	Characteristics (RT)			Dimensions		Weight(g)	Ref. No.
	Nominal Voltage (V)	Standard ¹ Capacity (mAh)	Standard Discharge Current (μA)	Diameter (mm)	Height (mm)		
SR416SW	1.55	7.5	10	4.8	1.65	0.11	337
SR421SW	1.55	12	20	4.8	2.15	0.14	348
SR512SW	1.55	5.5	5	5.8	1.25	0.15	335
SR516SW	1.55	12.5	20	5.8	1.65	0.18	317
SR521SW	1.55	13	20	5.8	2.15	0.23	379
		16	30				
SR527SW	1.55	22	40	5.8	2.70	0.29	319
SR616SW	1.55	16	20	6.8	1.65	0.25	321
SR621SW	1.55	18	30	6.8	2.15	0.32	364
		23	40				
SR626SW	1.55	24	30	6.8	2.60	0.39	377
		26	40				
		30	40				
SR712SW	1.55	10	10	7.9	1.25	0.26	346
SR714SW	1.55	15	20	7.9	1.45	0.29	341
SR716SW	1.55	21	30	7.9	1.65	0.33	315
SR721SW	1.55	23	40	7.9	2.10	0.42	362
		28	40				
SR726SW	1.55	34	40	7.9	2.60	0.52	397
SR731SW	1.55	36	50	7.9	3.10	0.56	329
SR41SW	1.55	45	50	7.9	3.60	0.67	384
SR912SW	1.55	15	20	9.5	1.25	0.40	—
SR916SW	1.55	27	50	9.5	1.65	0.51	373
SR920SW	1.55	35	50	9.5	2.05	0.60	371
		46	60				
SR927SW	1.55	53	80	9.5	2.70	0.75	395
		60	100				
SR936SW	1.55	80	140	9.5	3.60	1.10	394
SR1120SW	1.55	53	80	11.6	2.05	0.93	381
SR1130SW	1.55	80	100	11.6	3.05	1.29	390
SR43SW	1.55	120	150	11.6	4.20	1.75	301
SR44SW	1.55	160	180	11.6	5.40	2.20	303

*1 The standard capacity is calculated by the measurement result of discharging time with the standard discharge current to the voltage 1.2V.

High Drain Battery Lineup

Type	Characteristics (RT)			Dimensions		Weight(g)	Ref. No.
	Nominal Voltage (V)	Standard ¹ Capacity (mAh)	Standard Discharge Current (μA)	Diameter (mm)	Height (mm)		
SR626W	1.55	28	50	6.8	2.60	0.39	376
SR721W	1.55	26	50	7.9	2.10	0.41	361
SR726W	1.55	34	50	7.9	2.60	0.52	396
SR41W	1.55	45	80	7.9	3.60	0.67	392
SR920W	1.55	42	80	9.5	2.05	0.60	370
SR927W	1.55	53	90	9.5	2.70	0.75	399
		60	110				
SR1120W	1.55	53	90	11.6	2.05	0.93	391
SR1130W	1.55	80	130	11.6	3.05	1.29	389
SR43W	1.55	120	220	11.6	4.20	1.75	386
SR44W	1.55	160	250	11.6	5.40	2.20	357

*1 The standard capacity is calculated by the measurement result of discharging time with the standard discharge current to the voltage 1.2V.

CHECK SHEET

If you are considering the purchase of one or more of our microbatteries or capacitors, please complete this check sheet and send it to us.

We will let you know which products will be optimum for you to use.

1. Products of interest

Rechargeable Battery Capacitor Silver Oxide Battery

2. Application circuits

3. Applications

As a power supply backup. As a main power supply.

If for backup power supply, load device is: RTC (Realtime clock) Other

4. Current consumption of load device

_____ μ A / mA

5. Minimum operating voltage of load device

_____ V

6. Required discharge time

_____ second / ms / μ s (If for pulsed discharging)

_____ minute / hour / day / month (If for loads such as main power applications, RTC backup power, etc.)

7. Usage environment temperature

8. Mounting

Reflow mounting required Reflow mounting not required

9. Service life of application

10. Desired charge voltage and charge time for rechargeable batteries and capacitors

_____ V, _____ hour

Green Plan and Environmental Policy

SII Green Plan Concept

The SII Group has formulated the Green Plan based on the "Three Green" concept of "Green Process, Green Products, and Green Life," under which the company practices environmentally conscious management.

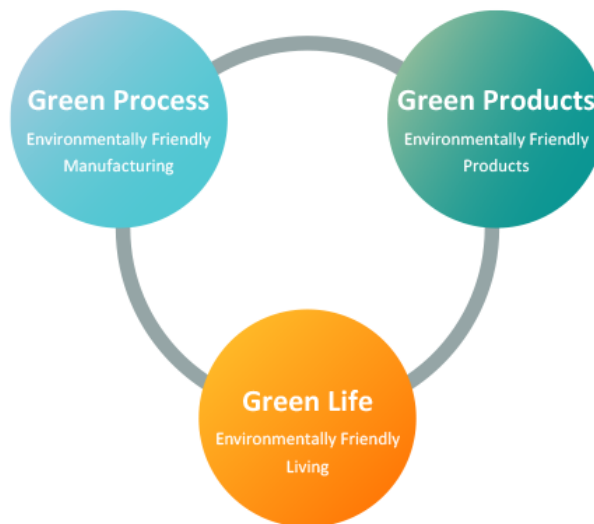

SII Group Environmental Policy

SII had previously established an environmental policy for the SII Group, but when the Environmental Policy of its parent company, Seiko Holdings Corporation (now Seiko Group Corporation), was revised in November 2021, SII decided to comply with Seiko Holdings Corporation's Environmental Policy.

Environmental Policy

The Seiko Group recognizes that the preservation of the global environment is one of the most important issues in the world today. We will constantly strive to help realize a sustainable society that will benefit everyone.

1. We are committed to a wide range of environmentally responsible activities, and we will continue to make unceasing efforts to improve our environmental performance, thereby providing increased value for all our stakeholders.
2. We not only comply with all relevant laws and regulations, but also go far beyond legal compliance in our efforts to reduce environmental risks and prevent pollution.
3. Being acutely aware of the part we have to play in mitigating climate change, we are working hard to reduce greenhouse gas emissions.
4. Because we recognize the limits of our precious natural resources, we are increasing our efforts to reuse and recycle every resource possible.
5. We are also working to preserve biodiversity, recognizing that our business activities inevitably affect surrounding ecosystems, and that we also benefit from the health and diversity of those systems.
6. We rigorously ensure proper management of all chemical substances used in production as well as any that are contained in our finished products.
7. We consider the environment throughout the entire life cycle of our products. We are proud that our products and services actively contribute to environmental conservation.
8. Environmental responsibility starts as a management imperative, but to effectively carry out that mission requires the understanding and cooperation of every employee throughout our Group. With that in mind, we are working to raise everyone's environmental awareness so that all of us can work together to protect and nurture our natural environment.
9. Transparency is another part of our social responsibility. We are therefore promoting active disclosure of material information about our environmental activities and promoting increased communication with local, regional, and global stakeholders.
10. In order to derive maximum benefits from these policies, we establish clear environmental targets and strategies to attain them. Then we steadily improve our efforts by constantly re-examining both our targets and our progress towards achieving them.

Precautions for Your Safety

SII Lithium rechargeable batteries (MS, ML, TS) contain flammable organic solvents.

For your safety, please follow following prohibitions.

WARNING!

1. Do not charge by high current or high voltage.

Doing so may generate gas inside the battery, resulting swelling, fire, heat generation or bursting.

2. Do not heat, disassemble nor dispose of in fire

Doing so damages the insulation materials and may cause fire, heat generation, leakage or bursting.

3. Do not solder directly to the battery

If soldering is performed directly to the battery, the battery is heated up, consequently causing leakage, explosion or fire due to overheating from internal short-circuit.

4. Do not short.

If the (+) and (-) come into contact with metal materials, short-circuit occurs. As a result, fire, heat generation, leakage or bursting may occur.

5. Keep batteries out of the reach of children

It is dangerous if children swallow the battery. Keep batteries which are considered swallowable out of the reach of children. When designing mechanical hardware around the battery, make sure that the battery cannot be removed by children.

Swallowing may lead to burns, perforation of soft tissue, and death. Severe burns can occur within 2 hours of ingestion.

In case of ingestion of a battery, seek medical attention immediately.

6. Do not reverse placement of (+) and (-)

If the (+) and (-) side of the battery is reverse inserted, it may cause a short-circuit or over discharge of the battery on some equipment and it may induce overheating, explosion or fire.

7. Do not weld terminals to the battery

The heat by welding may cause fire, heat generation, leakage or bursting. We weld standard terminals under strictly controlled conditions.

If you need to weld terminals to the battery, please consult us in advance.

8. Do not discharge by force

If the battery is discharged by direct connection to an external power supply etc., voltage of the battery will decline lower than 0 volts (electrical reversal) and will cause the battery case to expand, overheat, leak, explode or burn.

9. In case of leakage or a strange smell, keep away from fire to prevent ignition of any leaked electrolyte.

10. In case of disposal, insulate between (+) and (-) of battery by an insulating material.

Jumbling batteries or with other metal materials cause short-circuit. As a result, fire, heat generation, leakage or bursting may occur.

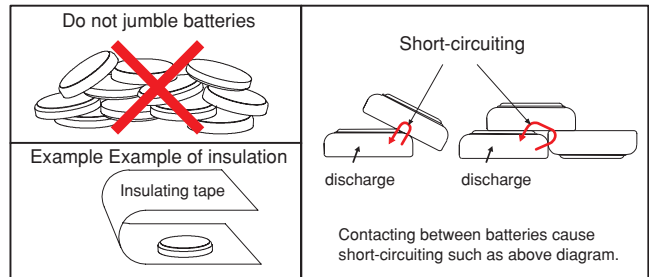

CAUTION!

1. If leaked liquid gets in the eyes, wash them with clean water and consult a physician immediately.

2. Do not use new and used batteries together. Do not use different types of batteries together.

It may cause fire, heat generation, leakage or bursting.

3. If you connect two or more batteries in series or parallel, please consult us in advance.

It may cause bursting or fire due to unbalanced load or voltage.

4. Do not use nor leave the batteries in direct sunlight nor in high-temperature areas.

It may cause fire, heat generation, leakage or bursting.

5. Do not apply strong pressure to the batteries nor handle roughly.

It may cause fire, heat generation, leakage or bursting.

6. Avoid contact with water.

It may cause heat generation.

7. Keep batteries away from direct sunlight, high temperature and humidity.

It may cause heat generation or performance deterioration.

8. Do not make batteries airtight by sealing it with adhesive agent or coating agent.

It may cause short-circuit because of generated and accumulated electrolyte gas.

For prevention of performance deterioration of battery

1. Pay attention to mat or sheet for ESD

Battery with tabs or battery on PCB may short circuit on the mat for ESD. As a result, the voltage of the cell is reduced.

2. Pay attention to soldering by tips

Do not touch the battery by soldering iron tips directly. Keep any high temperature process away from battery.

3. Pay attention to material of jig for pick and place

Use non-conductive material of jig for pick and place of batteries, for short-circuit protect. If short-circuit of battery occurs, the voltage of battery drops down quickly but raises gradually.

4. Pay attention to washing and drying

Some detergent or high temperature drying may cause deteriorate of battery. If you need to wash batteries, consult us.

International Transportation and Disposal

• International Air / Marine / Ground Transportation

Lithium batteries are classified as Class 9 dangerous goods by the UN Recommendations, and related organizations such as IATA, ICAO, IMO, and DOT have established regulations on air, ship, and land transportation based on the UN Recommendation.

[Transporting our lithium batteries by air]

When transporting lithium batteries by air, in addition to the requirements of the UN Recommendations, all the requirements of the "IATA Dangerous Goods Regulations (IATA-DGR)" must be met. Furthermore, for air transportation to and from the United States, the requirements of the "Code of Federal Regulations (49CFR)" must also be met.

Our lithium batteries correspond to the category of lithium metal batteries with a lithium content of 1 g or less and meet the requirements of UN Manual of Tests and Criteria, Part III, sub-section 38.3, so they can be transported as Class 9 Dangerous Goods. For details, please contact us.

Our shipping packaging specifications meet the requirements of UN recommendations and the above regulations. If you use our original packaging and need any certificates for the transportation, please contact us through your purchasing route. If you pack the lithium batteries yourselves, please note that you will need to conduct your own packaging tests and certifications.

When shipping lithium batteries by air, only cargo aircraft are allowed to transport them.

Each carrier may have its own voluntary regulations, so please check with each carrier in advance for details.

[Transporting our lithium batteries by sea]

Our lithium batteries are subject to the International Maritime Dangerous Goods Code (IMDG-Code) Special Provision 188 (SP188), and can be transported as exempted dangerous goods if they do not exceed 30kg per package and meet all the IMDG-Code transport requirements.

• Disposal

Recently environmental protection regulations have increased and battery disposals are regulated globally.

Such regulations are different in each country, state, and municipality.

Please consult your local authorities regarding the specific regulations in your area.

Micro-Energy Division capacitors (CPH, CPM) contain flammable organic solvents. For your safety, please follow the following precautions.

 **WARNING!**

- **Do not charge by higher current or higher voltage than specified.**
Doing so may generate gas inside the capacitor, resulting in swelling, fire, heat generation or bursting.
- **Do not reverse placement of (+) and (-)**
SII capacitors have polarity. If the (+) and (-) side of the capacitor is reverse inserted, it may cause short-circuit or over discharge of the capacitor on some equipment and it may induce overheating, explosion or fire.
- **Keep capacitors out of children's reach.**
It is dangerous that children swallow the capacitor.
When you design mechanical hardware around the capacitor, please fix the capacitor firmly in order to prevent children from removing it.

When you store the capacitors, please keep the capacitors out of children's reach. If a capacitor is swallowed, consult a physician immediately.

- **Do not heat, disassemble nor dispose of in fire**
Doing so damages the insulation materials and may cause fire, heat generation, leakage or bursting.
- **Do not discharge by force**
If the capacitor is discharged by direct connection to an external power supply etc., voltage of the capacitor will decline lower than 0 volts (electrical reversal) and will cause the capacitor case to expand, overheat, leak, explode or burn.
- **In case of leakage or a strange smell, keep away from fire to prevent ignition of any leaked electrolyte.**

 **CAUTION!**

- **If leaked liquid gets in the eyes, wash them with clean water and consult a physician immediately.**
- **Do not use nor leave the capacitors in direct sunlight nor in high-temperature areas.**
It may cause fire, heat generation, leakage or bursting.
- **When using molding resin or coating resin, check carefully the ingredients and hygroscopicity of them.**
Some kind of resin may cause deterioration or corrosion.

- **Do not use new and used capacitors together. Do not use different types of capacitors together.**
It may cause fire, heat generation, leakage or bursting.
- **If you connect two or more capacitors in series or parallel, please consult us in advance.**
It may cause bursting or fire due to unbalanced load or voltage.
- **Keep capacitors away from direct sunlight, high temperature and humidity.**
It may cause heat generation or performance deterioration.

For using SII Silver Oxide batteries, please follow the following precautions.

 **WARNING!**

- **Do not heat, disassemble nor dispose of in fire**
Doing so damages the insulation materials and may cause fire, heat generation, leakage or bursting.
- **Do not short.**
If the (+) and (-) come into contact with metal materials, shortcircuit occurs. As a result, fire, heat generation, leakage or bursting may occur.
- **Keep batteries out of children's reach.**
It is dangerous that children swallow the battery.
When you design mechanical hardware around the battery, please fix the battery firmly in order to prevent children from removing it.

When you store the batteries, please keep the batteries out of children's reach.
If a battery is swallowed, consult a physician immediately.

- **If leaked liquid, alkaline, get in the eyes, do not rub them, wash them with clean water and consult a physician immediately.**
- **If leaked liquid, alkaline, stick to clothing, for protecting from irritation, wash them with clean water immediately.**

 **CAUTION!**

- **Do not reverse placement of (+) and (-)**
- **Do not solder directly to the battery**
- **Do not use new and used batteries together. Do not use different types of batteries together.**
- **Do not charge.**
- **Do not use nor leave the batteries in direct sunlight nor in high-temperature areas.**
- **Keep batteries away from direct sunlight, high temperature and humidity.**
- **Avoid letting battery contact water.**

- **Make sure to insert batteries without having (+) and (-) come in contact with metal parts of equipment.**
- **Read the equipment instruction manual and precautions carefully before using. Some usage or types of equipment do not suit the specifications or performance of these batteries.**
- **Remove batteries from the equipment, if finished using. Do not leave batteries connecting with equipment after using.**
- **In case of disposal, insulate between (+) and (-) of battery by an insulating material.**

IMPORTANT

1. The information herein is subject to change without notice.
2. Neither reproduction, duplication nor unauthorized use of this catalog in whole or part is allowed without the prior written approval of Seiko Instruments Inc.
3. The colors of the products reproduced herein ("Products") may be different from the actual colors. Check colors on actual products before using the Products.
4. Circuits and respective application methods described herein are for reference only. Seiko Instruments Inc. shall not be liable for any damages or losses resulting from any claim by third parties that any Products or application methods described herein infringe any right intellectual property right. All intellectual property rights with respect to the Products belong exclusively to Seiko Instruments Inc.

5. When Products include Strategic Products (or Services) stipulated in the Foreign Exchange and Trade Control Law, they shall not be exported without permission of governmental authorities.
6. The Products are designed for consumer equipment and cannot be used as part of any device or equipment which influences the human body or requires a significantly high reliability, such as physical exercise equipment, medical equipment, disaster prevention equipment, gas related equipment, vehicles, aircraft and equipment mounted on vehicles without our prior express written consent.

All data, dimensions, characteristics and values shown in this catalogue are for reference only. Please contact your local Seiko Instruments Representative for current detailed specifications.



Micro-Energy Division who manufactures the products described in this catalog holds the ISO 9001 quality management system certificate, and the ISO 14001 environmental management systems certificate.



www.sii-me.com

Seiko Instruments Inc.

Electronic Components Sales Head Office
 1-8, Nakase, Mihamaku, Chiba-shi, Chiba 261-8507, Japan
 Telephone: +81-43-211-1735 Facsimile: +81-43-211-8034

Asia

Seiko Instruments Trading (H.K.) Ltd.
 7/F, Ying Tung Industrial Building,
 802 Lai Chi Kok Road, Kowloon, Hong Kong
 Telephone: +852- 2494-5111
 Facsimile: +852- 2424-0901

Seiko Instruments (Shanghai) Inc.
 Room 2701, 27th Floor,
 Shanghai Plaza,
 138 Mid Huaihai Rd.,
 Shanghai 200021, China
 Telephone: +86-21-6375-6611
 Facsimile: +86-21-6375-6727

Seiko Instruments Taiwan Inc.
 2F., No. 143, Changchun Rd.,
 Taipei, Taiwan R.O.C.
 Telephone: +886-2-2563-5001
 Facsimile: +886-2-2563-5580

Seiko Instruments (Shanghai) Inc. Shenzhen Branch
 Room 2215, Office Tower, Shun Hing
 Square Di Wang Commercial Centre,
 5002 Shen Nan Dong Road, Shenzhen,
 518008, China
 Telephone: +86-755-8246-2680
 Facsimile: +86-755-8246-5140

Europe

Seiko Instruments GmbH
 Siemensstrasse 9
 D-63263 Neu Isenburg, Germany
 Telephone: +49-6102-297-0
 Facsimile: +49-6102-297-50100
 Email: info@seiko-instruments.de
 http://www.seiko-instruments.de

North/Central/South America

Seiko Instruments U.S.A., Inc.
 21221 S. Western Ave., Suite 250,
 Torrance, CA 90501, U.S.A.
 Telephone: +1-310-517-7802
 Facsimile: +1-310-517-7792
 Email: info@seikoinstruments.com
 http://www.sii-me.com

(Specifications are subject to change without notice.)

Released in April 2023

Contact us