

DHS1 Series

Digital Dual Output Hall Switch

- Dual output hall switch for targeted magnetic detection
- Digital output for clear ON/OFF signal
- Non-contact, solid-state design with no moving parts
- 55 gauss operate (1 output for N pole, 1 output for S pole)
- Ideal for speed, position, and proximity sensing in mobile and industrial systems



CUSTOMER FOCUSED ENGINEERING + MODULAR DESIGN

Part Description: **M12-DHS1-5KSA5**

Housing	Series	Electrical Option	Connection Type
See page 2-3	DHS1	See page 4	See page 5-6

Modify, update, or enhance any sensor with our modular features and functionality.

HOUSING - Aluminum, stainless steel, plastic, threaded, flange mount, customer specific

ELECTRICAL - Every sensor function available in various electrical options (NPN, PNP, TTL, etc.)

CONNECTION - Deutsch, Amphenol, many other brands, free end wires, pigtails, any length

Need a Custom Sensor Solution?... Send us your application specific requirements at sensorso.com

'Dual Digital Output' Hall Switch Sensor

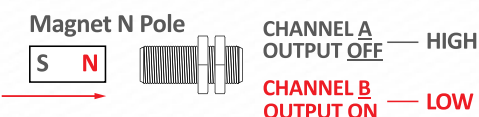
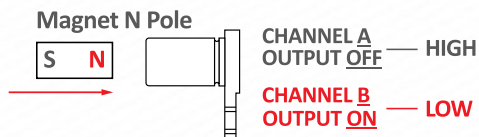
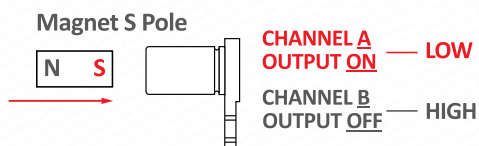

FEATURES

- Non-contact
- Easy to install
- Internal hysteresis
- Temperature stable
- Shock and vibration resistant

APPLICATIONS

- Alignment or proximity of manufacturing bins/carts/trays
- Count feedback of production and testing components
- Min/Max Position Detection
- Monitors speed in conveyor systems and assembly lines

MARKETS

- Aerospace & Defense
- Medical Devices
- Agricultural Machinery
- Marine & Transportation

- Solid-state (no wearing parts)
- Detect non-standard steel targets
- Harsh environment durability
- Flexible electrical options: NPN or PNP outputs
- Easy installation with threaded or flange mount housings

- Speed of automation equipment
- Measure cranes/winch feed rate
- Resolving engine RPMs
- Measuring vehicle/wheel speed
- Pulley systems in manufacturing
- Monitoring gears in transmissions
- Cam and Crank shaft timing

- Automotive & Heavy Equipment
- Power Generation Systems
- Consumer Electronics
- Manufacturing & Industrial Automation

DHS1 Series

Digital Dual Output Hall Switch

303 Stainless Steel

PART NUMBER M 1 2 - D H S 1 - 5 K S A 5 - CONNECTION
EXAMPLE HOUSING ELECTRICAL

S12 Thread Mount M12x1mm, 35mm

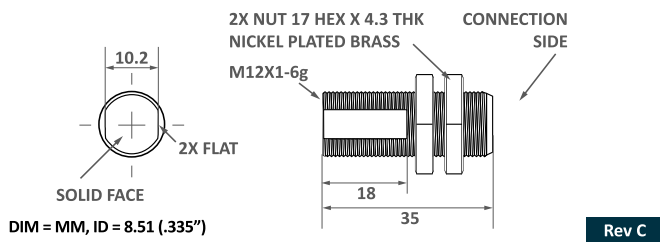

S38 Thread Mount M12x1mm, 3/8-24, 1.3in

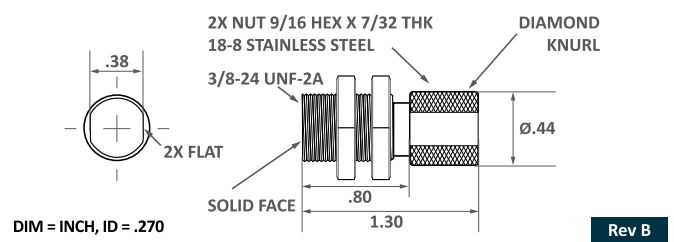

S8 Thread Mount M8x1mm, 32mm

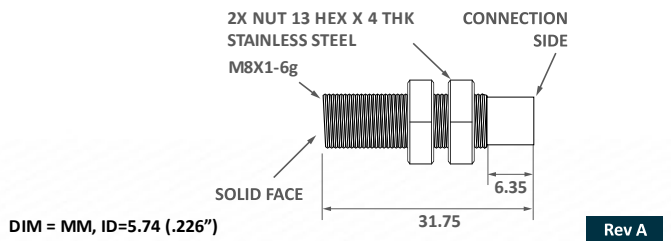

DHS1 Series

Digital Dual Output Hall Switch

Electrical Output Logic Options

PART NUMBER EXAMPLE M 1 2 - D H S 1 - 5 K S A 5 — CONNECTION
 HOUSING ELECTRICAL

P5

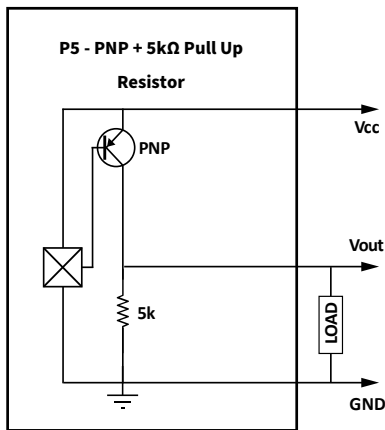

Electrical Specifications	Conditions	Min	Max	Unit
Temperature Range*	Operating	-40	+110*	Deg C
Supply Voltage, Vcc	Over temperature	+5	+24	Volts DC
Supply Current, Output Off	Into Vcc, Vcc = 24V	+1.5	+5	mA
Frequency Range	Near zero speed	0.1	15k	Hz
Saturation Voltage High	Vcc = 24V, Rpu >10k	23.5	24	Volts
Saturation Voltage Low	Vcc = 24V, Rpu >10k	0.1	0.5	Volts
Internal Pull Up Resistor	Vcc to Vout	none	none	kohms
Output Resistance Ro	0.25 watts	48	52	Ohms
Output Rise Time 10-90%	Co < 100pF	-	8.0	µS
Output Fall Time 90-10%	Co < 100pF	-	2.0	µS
ESD **	Nondestructive	-	2000	Volts
EMI **	20k to 1 G Hz	-	100	V / M

* T max = 150°C is available, contact factory.

Rev B

5K

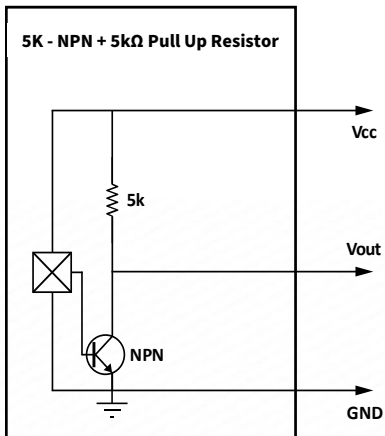

Electrical Specifications	Conditions	Min	Max	Unit
Temperature Range*	Operating	-40	+110*	Deg C
Supply Voltage, Vcc	Over temperature	+4.2	+24	Volts DC
Supply Current, Output Off	Into Vcc, Vcc = 24V	+1.5	+5	mA
Frequency Range	Near zero speed	0.1	15k	Hz
Saturation Voltage Low	I sink=20mA	0	0.6	Volts
Internal Pull Up Resistor	Vcc to Vout	4.9	5.1	kohms
Output Rise Time 10-90%	C < 100pF	-	3.0	µS
Output Fall Time 90-10%	C < 100pF	-	1.0	µS
ESD **	Nondestructive	-	2000	Volts
EMI **	20k to 1 G Hz	-	100	V / M

* T max = 150°C is available, contact factory.

Rev B

DHS1 Series

Digital Dual Output Hall Switch

Cable Harness & Connector Options

PART NUMBER EXAMPLE M 1 2 - D H S 1 - 5 K S A 5 — CONNECTION
 HOUSING ELECTRICAL

CD4, 4 Pin Deutsch DT04 TXL 20 AWG Wires

Connections

Pin 1 (Red) = Vcc Pin 2 (Black) = Ground Pin 3 (White) = Channel A (S Pole) Pin 4 (Green) = Channel B (N Pole)

CONNECTOR: AMPHENOL AT04-4P-RD01 BODY OR DEUTSCH DT04-4P-C015 BODY
 CONTACTS: 4 DEUTSCH PINS, PN 1060-16-0622
 WIRE: 20AWG, 19/32, XLPE TXL, 125°C

PIN 1 = RED
 PIN 2 = BLACK
 PIN 3 = WHITE
 PIN 4 = GREEN

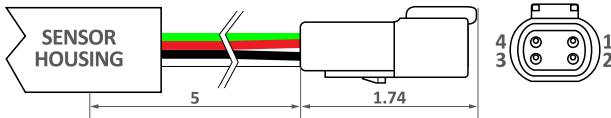

DIM = INCH

Rev B

DHS1 Series

Digital Dual Output Hall Switch

Environmental & Performance Specifications

Sensor Function

Magnetic Characteristics	Min	Typ	Max
Operate Point Over Temp	15 G	55 G	76 G
100% Tested at 20°C before shipping			
Release Point Over Temp	5 G	35 G	57 G
Hysteresis Over Temp	5 G	20 G	28 G

MAGNET OR MAGNETIC FIELD
EXAMPLE MAGNET
PN: RM-01-020

S POLE CH A ON
N POLE CH B ON

AIR GAP

0.60 TYP DETECT GAP
1/4" NEO MAGNET

NO ORIENTATION REQUIRED

"S" ENGRAVED ON S POLE SIDE

0.25"

Ø.25"

DIM=INCH

Material Specs (25°C)	Typ	Min
300-01-020 NEO 35 SH		
Processing Type	Sintered	
BR Gauss	12,000	11,700
HC Oersted	11,500	11,000
HCI Oersted	-	21,000
BH Max MGOE	35	33
BR Temp CO (%/°C)	-0.10	-
Recoil Perm. (UREC)	-	-
TC Curie Temp (°C)	310	-
Max Operating Temp (°C)	150	-
Plating, NI (Mils)	0.4-0.7	0.4

Marking

Environmental Specifications

Corrosion Resistance	500 hours salt spray ASTM B-117
Installation Torque	13 Foot-Pounds Maximum
Enclosure	Nema 1,3,4,6,13 & IEC IP67
Vibration	10 G's 2 to 2000 Hz Continuous
Mechanical Shock	100 G's, 11 mS

Please note: All technical specifications on this series datasheet refer to the standard product range. Modifications in the sense of technical progress are reserved. For general information only. For more specific information, please consult the product datasheet, available upon request.

This series datasheet could contain technical inaccuracies or typographical errors. Changes are periodically made to the information herein. These change will be incorporated in future revisions.

For deviating values, most current specifications and products please contact your nearest sales office.

MFM7-DHS1-5KCD4

Dual Output Hall Switch Sensor

- Dual output hall switch
- 55 gauss operate (1 output for N pole, 1 output for S pole)
- NPN output with 5k pull up resistor
- Plastic .7" flange mount 1.5" long housing
- Deutsch DT04 4 pin with 5" 20 AWG XLPE

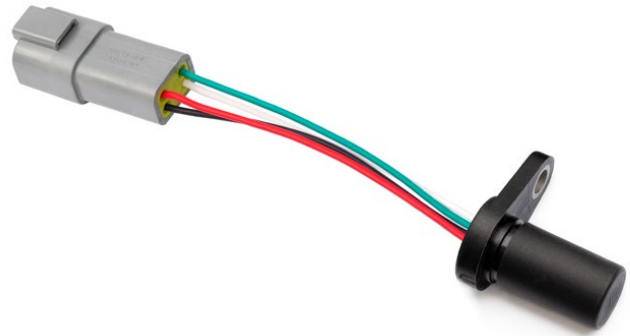

CUSTOMER FOCUSED ENGINEERING + MODULAR DESIGN

Part Description: **MFM7-DHS1-5KCD4**

Housing	Sensor Type & Function	Electrical Option	Connection Type
Glass Filled Nylon Flange Mount Ø.7" x 1.5"	Dual Output Hall Switch Sensor	NPN, 5k Pull Up Resistor	Deutsch DT 4 pin w/5" 20AWG XLPE

Modify, update, or enhance any sensor with our modular features and functionality.

HOUSING - Aluminum, stainless steel, plastic, threaded, flange mount, customer specific

ELECTRICAL - Every sensor function available in various electrical options (NPN, PNP, TTL, etc.)

CONNECTION - Deutsch, Amphenol, many other brands, free end wires, pigtails, any length

Need a Custom Sensor Solution?... Send us your application specific requirements at sensorso.com

'Dual Output' Hall Switch Sensor

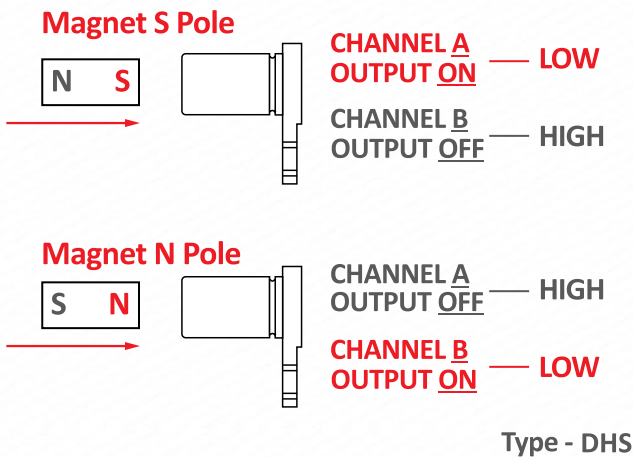

DESCRIPTION

- Sensor produces dual pulsing outputs, 1 South Pole and 1 North Pole.
- Functions as directional limit switch when magnets are mounted at each end of range of motion.
- No orientation required. Use lock nuts to set air gap within range of target magnets.
- South Pole element is located closer to sensor face and will detect at a slightly greater operate gap.
- Note: Operate and release gaps are dependent on the size, material, grade, and temperature of the target magnet.

FEATURES

- True Zero Speed
- Greater Detection Gap Than Standard DHS Sensor
- Rugged, Sealed Housing
- Solid State (Nothing to wear out!)

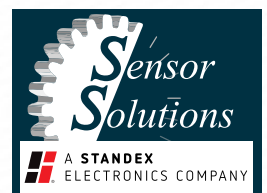

MFM7-DHS1-5KCD4

Dual Output Hall Switch Sensor

Note: Check our website or contact us to see all of our Options, including more and less sensitive choices.

Electrical Specifications	Conditions	Min	Max	Unit
Temperature Range*	Operating	-40	+110*	Deg C
Supply Voltage, Vcc	Over temperature	+4.5	+28	Volts DC
Supply Current, Output Off	Into Vcc	+4	+14	mA
Frequency Range		0	20	kHz
Internal Pull Up Resistor	Vcc to Vout	4.9	5.1	kOhms
Saturation Voltage Low 100% tested at 20°C before shipping	Vcc=12V, Rload >100k	0	.4	Volts
Saturation Voltage High 100% tested at 20°C before shipping	Vcc=12V, Rload >100k	11.5	12	Volts
Output Rise Time 10-90%	C < 100pF	-	8.0	µS
Output Fall Time 90-10%	C < 100pF	-	2.0	µS
ESD **	Nondestructive	-	8000	Volts
EMI **	20k to 1 G Hz	-	100	V / M

* T max = 150°C is available, contact factory.

** Specifications not available at release.

Rev B

Absolute Max Limits	Min	Max	Unit
Supply Voltage, Vcc	-15	+28	Volts DC
Voltage Applied to Output	-0.3	+28	Volts
Current Into Output	-	25	mA
Current Out of Output	-	Vcc/5k	mA
Load Dump, 40 mS Rs = 20	-	60	Volts

Environmental Specifications

Corrosion Resistance	500 hours salt spray ASTM B-117
Installation Torque	15 Foot-Pounds Maximum
Enclosure	Nema 1,3,4,6,13 & IEC IP67
Vibration	10 G's 10 to 2000 Hz Sinusodal
Mechanical Shock	50 G's, 11 mS Half-Sine

MFM7, Glass Filled Nylon (150°C) Flanged Housing

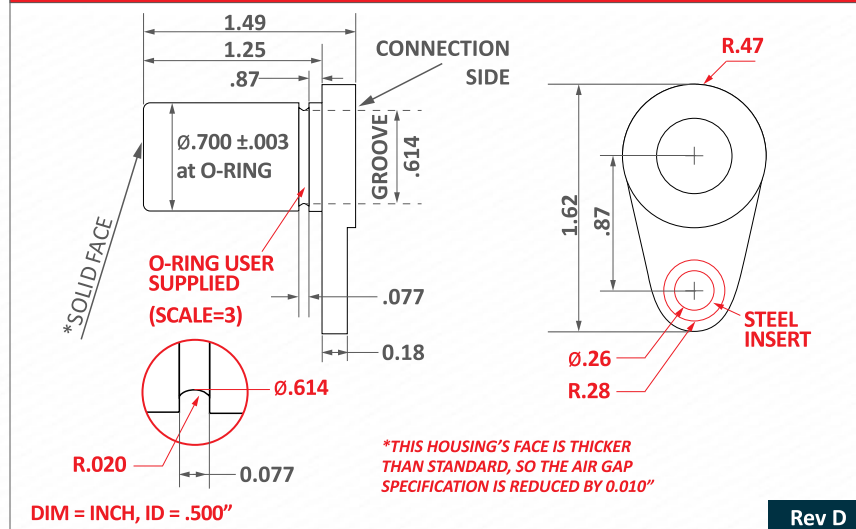

Rev D

Magnetic Characteristics	Min	Typ	Max
Operate Point Over Temp 100% tested at 20°C before shipping	15 G	55 G	76 G
Release Point Over Temp	5 G	35 G	57 G
Hysteresis Over Temp	5 G	20 G	28 G
Inside Depth to N pole Element	-	.060"	-
Inside Depth to S pole Element	-	.090"	-

MFM7-DHS1-5KCD4

Dual Output Hall Switch Sensor

CD4, 4 Pin Deutsch DT04 w/5" 20 AWG TXL

CONNECTOR: AMPHENOL AT04-4P-RD01 BODY OR DEUTSCH DT04-4P-C015 BODY
CONTACTS: 4 DEUTSCH PINS, PN 1060-16-0622
WIRE: 20AWG, 19/32, XLPE TXL, 125°C

PIN 1 = RED
PIN 2 = BLACK
PIN 3 = WHITE
PIN 4 = GREEN

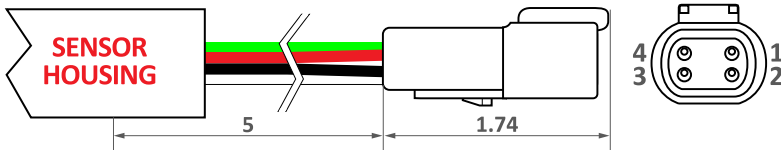

DIM = INCH

Rev B

Sensor Function

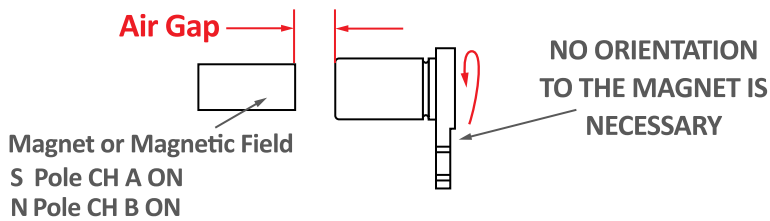

MFM7-DHS

Connections Chart

Pin 1 (Red) Vcc	Pin 3 (White) S Pole Vout
Pin 2 (Black) Ground	Pin 4 (Green) N Pole Vout
CD4-DHS1	

Date Code 'YYM' YY = YEAR, M = MONTH

A JAN	D APR	H JUL	L OCT
B FEB	E MAY	J AUG	M NOV
C MAR	G JUN	K SEP	N DEC

Marking

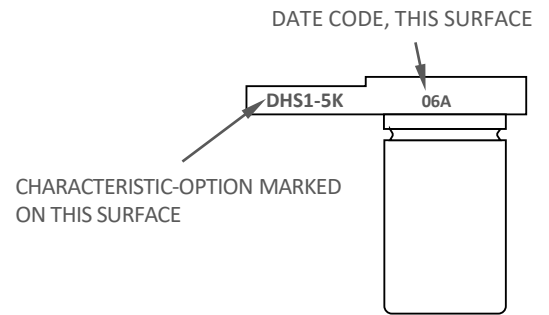

5K, 5k Pull-up Resistor

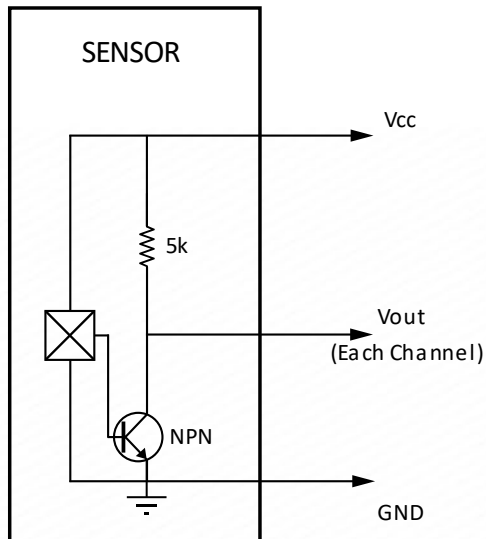

Handling Instructions

**DO NOT CONTACT
FACE TO FACE**

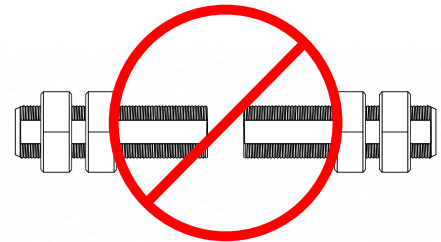

**CONTACT WITH OTHER MAGNETS MAY
REDUCE THE MAXIMUM OPERATING GAP**

Please note: All technical specifications on this series datasheet refer to the standard product range. Modifications in the sense of technical progress are reserved. For general information only. For more specific information, please consult the product datasheet, available upon request.

This series datasheet could contain technical inaccuracies or typographical errors. Changes are periodically made to the information herein. These change will be incorporated in future revisions.

For deviating values, most current specifications and products please contact your nearest sales office.

S12-DHS1-5KSA5

Dual Output Hall Switch Sensor

- Dual output hall switch
- 55 gauss operate
- NPN w/5k pull up resistor
- Stainless 12x1mm x 35mm housing
- Shielded 4 wire 22 AWG 80°C PVC, 5ft



CUSTOMER FOCUSED ENGINEERING + MODULAR DESIGN

Part Description: **S12-DHS1-5KSA5**

Housing	Sensor Type & Function	Electrical Option	Connection Type
S = Stainless Steel, Thread Pitch M12x1, 35mm Long	Dual Output Hall Switch Sensor	NPN, 5k Pull Up Resistor	SA Shielded 4 Wire 22 AWG 80°C PVC

Modify, update, or enhance any sensor with our modular features and functionality.

HOUSING - Aluminum, stainless steel, plastic, threaded, flange mount, customer specific

ELECTRICAL - Every sensor function available in various electrical options (NPN, PNP, TTL, etc.)

CONNECTION - Deutsch, Amphenol, many other brands, free end wires, pigtails, any length

Need a Custom Sensor Solution?... Send us your application specific requirements at sensorso.com

'Dual Output' Hall Switch Sensor

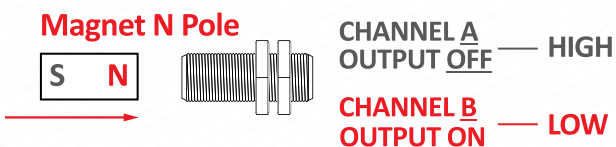
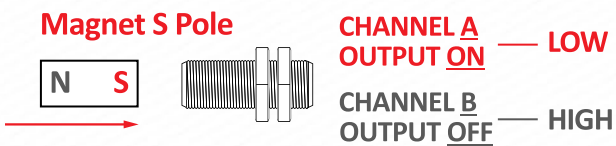

Type - DHS

DESCRIPTION

- Sensor produces dual pulsing outputs, 1 South Pole and 1 North Pole.
- Functions as directional limit switch when magnets are mounted at each end of range of motion.
- No orientation required. Use lock nuts to set air gap within range of target magnets.
- South Pole element is located closer to sensor face and will detect at a slightly greater operate gap.
- Note: Operate and release gaps are dependent on the size, material, grade, and temperature of the target magnet.

FEATURES

- Rugged, Sealed Housing
- Greater Detection Gap Than Standard DHS Sensor
- Solid State (Nothing to wear out!)

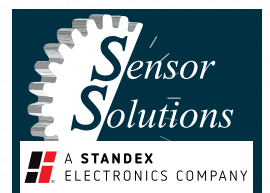

S12-DHS1-5KSA5

Dual Output Hall Switch Sensor

Note: Check our website or contact us to see all of our Options, including more and less sensitive choices.

Electrical Specifications	Conditions	Min	Max	Unit
Temperature Range*	Operating	-40	+110*	Deg C
Supply Voltage, Vcc	Over temperature	+4.5	+28	Volts DC
Supply Current, Output Off	Into Vcc	+4	+14	mA
Frequency Range		0	20	kHz
Internal Pull Up Resistor	Vcc to Vout	4.9	5.1	kOhms
Saturation Voltage Low 100% tested at 20°C before shipping	Vcc=12V, Rload >100k	0	.4	Volts
Saturation Voltage High 100% tested at 20°C before shipping	Vcc=12V, Rload >100k	11.5	12	Volts
Output Rise Time 10-90%	C < 100pF	-	8.0	µS
Output Fall Time 90-10%	C < 100pF	-	2.0	µS
ESD **	Nondestructive	-	8000	Volts
EMI **	20k to 1 G Hz	-	100	V / M

* T max = 150°C is available, contact factory.

** Specifications not available at release.

Rev B

Absolute Max Limits	Min	Max	Unit
Supply Voltage, Vcc	-32	+32	Volts DC
Voltage Applied to Output	-0.3	+28	Volts
Current Into Output	-	25	mA
Current Out of Output	-	Vcc/5k	mA
Load Dump, 40 mS Rs = 20	-	60	Volts

Environmental Specifications

Corrosion Resistance	500 hours salt spray ASTM B-117
Installation Torque	23 Foot-Pounds Maximum
Enclosure	Nema 1,3,4,6,13 & IEC IP67
Vibration	10 G's 2 to 2000 Hz Sinusoidal
Mechanical Shock	100 G's, 11 mS Half-Sine

S12 Housing, 303 Stainless Steel, M12X1, 35mm Long

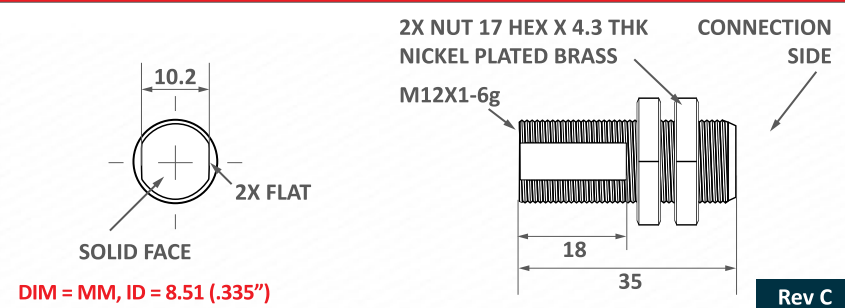

Rev C

Magnetic Characteristics	Min	Typ	Max
Operate Point Over Temp 100% tested at 20°C before shipping	15 G	55 G	76 G
Release Point Over Temp	5 G	35 G	57 G
Hysteresis Over Temp	5 G	20 G	28 G
Inside Depth to N pole Element	-	.060"	-
Inside Depth to S pole Element	-	.090"	-

SA5, Shielded 4 Wire 22 AWG 80°C PVC

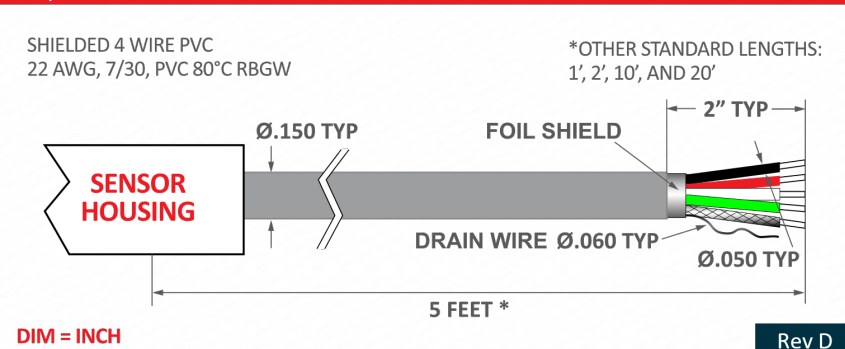

Rev D

Connections Chart

Pin 1 (Red)	Vcc	Pin 3 (White)	S Pole Vout
Pin 2 (Black)	Ground	Pin 4 (Green)	N Pole Vout

S12-DHS

S12-DHS1-5KSA5

Dual Output Hall Switch Sensor

Sensor Function

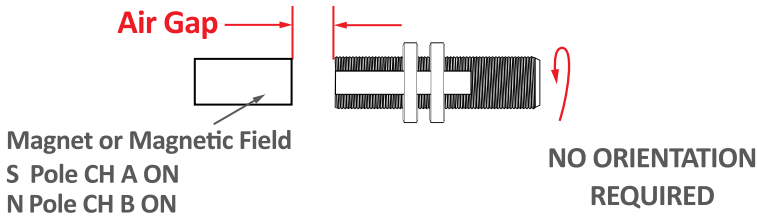

S12-DHS

5K, 5k Pull-up Resistor

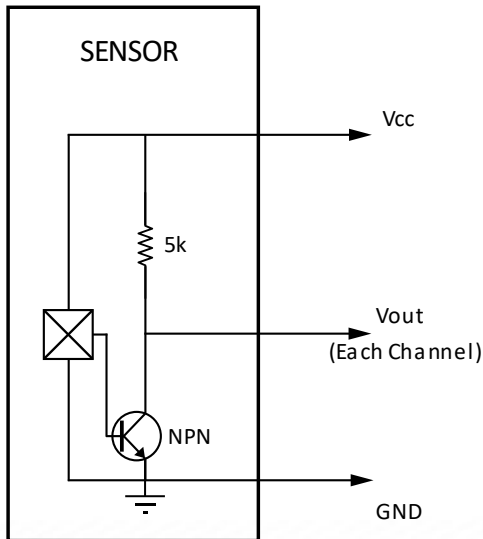

Date Code 'YYM'

YY = YEAR, M = MONTH

A JAN	D APR	H JUL	L OCT
B FEB	E MAY	J AUG	M NOV
C MAR	G JUN	K SEP	N DEC

Marking

DATE CODE, THIS SURFACE

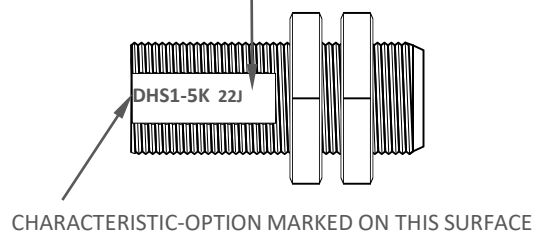

Handling Instructions

**DO NOT CONTACT
FACE TO FACE**

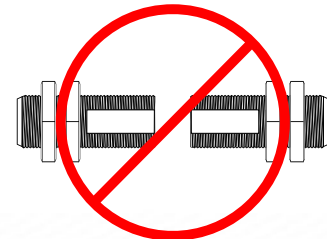

**CONTACT WITH OTHER MAGNETS MAY
REDUCE THE MAXIMUM OPERATING GAP**

Please note: All technical specifications on this series datasheet refer to the standard product range. Modifications in the sense of technical progress are reserved. For general information only. For more specific information, please consult the product datasheet, available upon request.

This series datasheet could contain technical inaccuracies or typographical errors. Changes are periodically made to the information herein. These change will be incorporated in future revisions.

For deviating values, most current specifications and products please contact your nearest sales office.

S63B-DHS1-5KCB2A

Dual Output Hall Switch Sensor

- Dual output hall switch
- 55 gauss operate
- NPN w/5k pull up resistor
- Stainless 5/8-18 x 2.5" MS opt housing
- Integral 4 pin male 12mm micro connector



CUSTOMER FOCUSED ENGINEERING + MODULAR DESIGN

Part Description: **S63B-DHS1-5KCB2A**

Housing	Sensor Type & Function	Electrical Option	Connection Type
Stainless Steel MS Opt 5/8-18 x 2.5" Long	Dual Output Hall Switch Sensor	NPN, 5k Pull Up Resistor	CB2A = Integral 4 Pin Male 12mm Micro Connector

Modify, update, or enhance any sensor with our modular features and functionality.

HOUSING - Aluminum, stainless steel, plastic, threaded, flange mount, customer specific

ELECTRICAL - Every sensor function available in various electrical options (NPN, PNP, TTL, etc.)

CONNECTION - Deutsch, Amphenol, many other brands, free end wires, pigtails, any length

Need a Custom Sensor Solution?... Send us your application specific requirements at sensorso.com

'Dual Output' Hall Switch Sensor

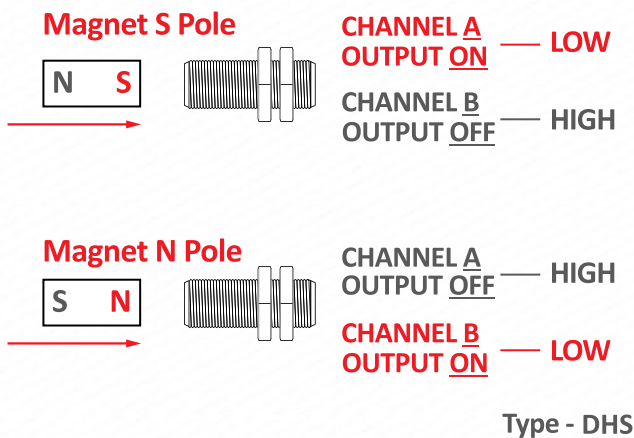

DESCRIPTION

- Sensor produces dual pulsing outputs, 1 South Pole and 1 North Pole.
- Functions as directional limit switch when magnets are mounted at each end of range of motion.
- No orientation required. Use lock nuts to set air gap within range of target magnets.
- South Pole element is located closer to sensor face and will detect at a slightly greater operate gap.
- Note: Operate and release gaps are dependent on the size, material, grade, and temperature of the target magnet.

FEATURES

- True Zero Speed
- Greater Detection Gap Than Standard DHS Sensor
- Rugged, Sealed Housing
- Solid State (Nothing to wear out!)

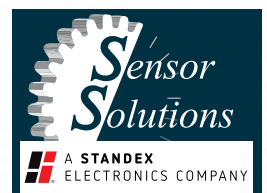

S63B-DHS1-5KCB2A

Dual Output Hall Switch Sensor

Note: Check our website or contact us to see all of our Options, including more and less sensitive choices.

Electrical Specifications	Conditions	Min	Max	Unit
Temperature Range*	Operating	-40	+110*	Deg C
Supply Voltage, Vcc	Over temperature	+4.5	+28	Volts DC
Supply Current, Output Off	Into Vcc	+4	+14	mA
Frequency Range		0	20	kHz
Internal Pull Up Resistor	Vcc to Vout	4.9	5.1	kOhms
Saturation Voltage Low 100% tested at 20°C before shipping	Vcc=12V, Rload >100k	0	.4	Volts
Saturation Voltage High 100% tested at 20°C before shipping	Vcc=12V, Rload >100k	11.5	12	Volts
Output Rise Time 10-90%	C < 100pF	-	8.0	µS
Output Fall Time 90-10%	C < 100pF	-	2.0	µS
ESD **	Nondestructive	-	8000	Volts
EMI **	20k to 1 G Hz	-	100	V / M

* T max = 150°C is available, contact factory.

** Specifications not available at release.

Rev B

Absolute Max Limits	Min	Max	Unit
Supply Voltage, Vcc	-32	+32	Volts DC
Voltage Applied to Output	-0.3	+28	Volts
Current Into Output	-	25	mA
Current Out of Output	-	Vcc/5k	mA
Load Dump, 40 mS Rs = 20	-	60	Volts

Environmental Specifications

Corrosion Resistance	500 hours salt spray ASTM B-117
Installation Torque	80 Foot-Pounds Maximum
Enclosure	Nema 1,3,4,6,13 & IEC IP67
Vibration	10 G's 2 to 2000 Hz Sinusoidal
Mechanical Shock	100 G's, 11 mS Half-Sine

S63B, Housing, 303 Stainless Steel, MS Opt 5/8-18, 2.5" Long

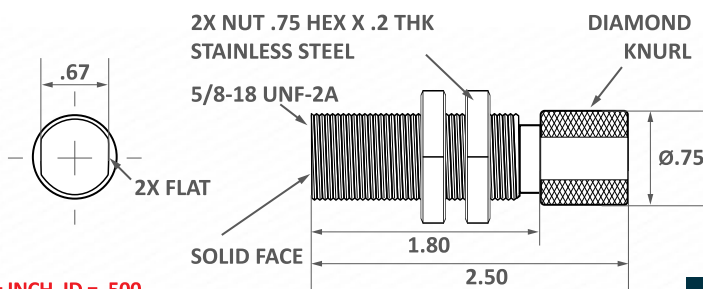

DIM = INCH, ID = .500

Rev C

CB2A, Integral 4 Pin Male 12mm Micro Connector

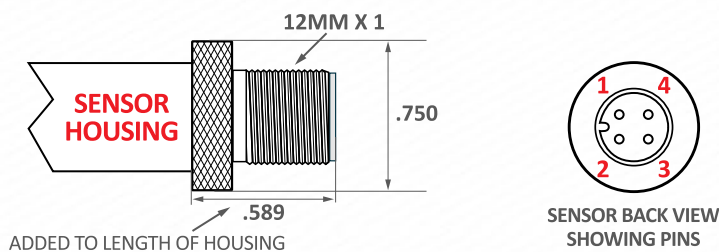

DIM = INCH

Rev B

Magnetic Characteristics	Min	Typ	Max
Operate Point Over Temp 100% tested at 20°C before shipping	15 G	55 G	76 G
Release Point Over Temp	5 G	35 G	57 G
Hysteresis Over Temp	5 G	20 G	28 G
Inside Depth to N pole Element	-	.060"	-
Inside Depth to S pole Element	-	.090"	-

Connections Chart

Pin 1	Vcc	Pin 3	Ground
Pin 2	N Pole Vout	Pin 4	S Pole Vout
CB2A-DHS			

OTHER MATING CONNECTORS AND CABLES AVAILABLE

S63B-DHS1-5KCB2A

Dual Output Hall Switch Sensor

Sensor Function

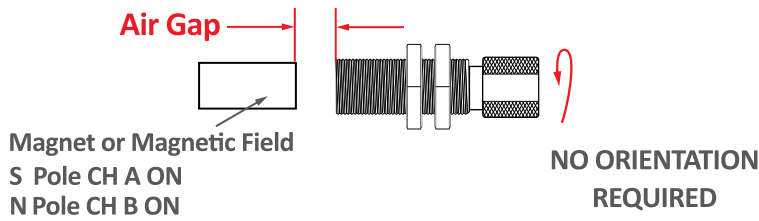

S63B-DHS

Date Code 'YYM'

YY = YEAR, M = MONTH

A JAN	D APR	H JUL	L OCT
B FEB	E MAY	J AUG	M NOV
C MAR	G JUN	K SEP	N DEC

Marking

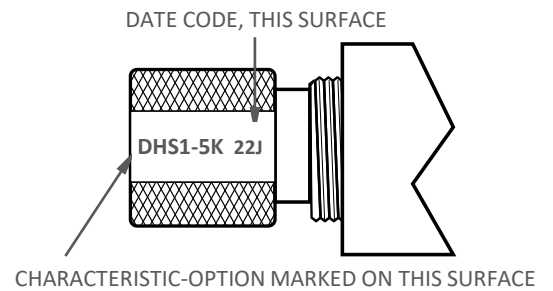

5K, 5k Pull-up Resistor

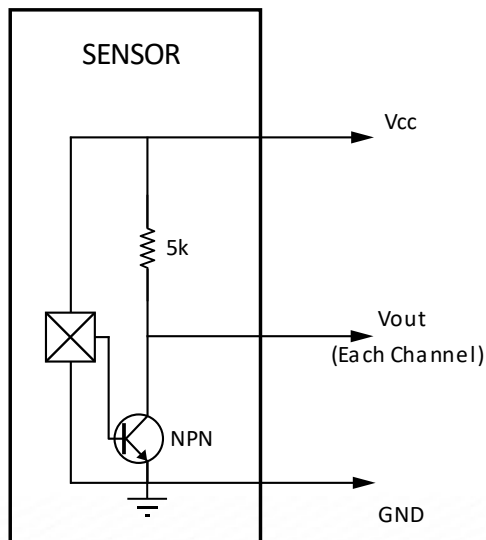

Handling Instructions

**DO NOT CONTACT
FACE TO FACE**

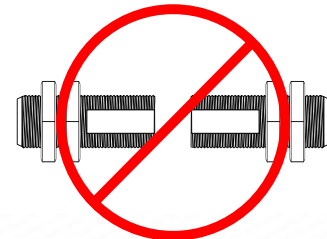

**CONTACT WITH OTHER MAGNETS MAY
REDUCE THE MAXIMUM OPERATING GAP**

Please note: All technical specifications on this series datasheet refer to the standard product range. Modifications in the sense of technical progress are reserved. For general information only. For more specific information, please consult the product datasheet, available upon request.

This series datasheet could contain technical inaccuracies or typographical errors. Changes are periodically made to the information herein. These change will be incorporated in future revisions.

For deviating values, most current specifications and products please contact your nearest sales office.