

## Intelligent IMU (inertial measurement unit) with simultaneous low-*g* and high-*g* acceleration detection



**LGA-14L**  
(2.5 x 3.0 x 0.83 mm) typ.

### Features

- Dual 3-axis accelerometer channels
  - Low-*g* channel  $\pm 2/\pm 4/\pm 8/\pm 16$  g full scale
  - High-*g* channel  $\pm 32/\pm 64/\pm 128/\pm 256$  g full scale
- 3-axis gyroscope with extended selectable full scale
  - $\pm 250/\pm 500/\pm 1000/\pm 2000/\pm 4000$  dps full scale
- Programmable finite state machine for accelerometer (low-*g* & high-*g*), gyroscope, and external sensor data processing with high rate @ 960 Hz
- Machine learning core with exportable features and filters for AI applications
- Embedded adaptive self-configuration (ASC)
- Embedded sensor fusion low-power (SFLP) algorithm
- Smart FIFO up to 4.5 KB
- "Smart, always-aware" experience for system power optimization
- Supply current
  - 6-axis configuration @ 0.67 mA in combo high-performance mode
  - 6-axis configuration with dual accelerometer full scale @ 0.80 mA in combo high-performance mode
- SPI / I<sup>2</sup>C & MIPI I3C<sup>®</sup> v1.1 serial interface with main processor data synchronization
- Auxiliary SPI & MIPI I3C<sup>®</sup> v1.1 for OIS data output for gyroscope and accelerometer
- Smart digital features: advanced pedometer, step detector, step counter, significant motion detection, tilt detection
- Standard interrupts: high-*g* wake-up and high-*g* shock, free-fall, wake-up, 6D/4D orientation, click and double click
- Embedded temperature sensor
- Analog supply voltage: 1.71 V to 3.6 V
- Independent I/O supply (extended range: 1.08 V to 3.6 V)
- Compact footprint: 2.5 mm x 3 mm x 0.83 mm
- ECOPACK and RoHS compliant

#### Product status link

[ISM6HG256X](#)

#### Product summary

<b>Order code</b>	ISM6HG256XTR
<b>Temp. range [°C]</b>	-40 to +105
<b>Package</b>	LGA-14L (2.5 x 3.0 x 0.83 mm)
<b>Packing</b>	Tape and reel

#### Product resources

[AN6353](#) (device application note)  
[AN6354](#) (finite state machine)  
[AN6355](#) (machine learning core)  
[TN0018](#) (handling, mounting, and soldering guidelines)

#### Product label



## Applications

- Condition monitoring
- Asset tracking
- Robotics
- Factory automation
- Safety helmets / hard hats
- Black boxes

## Description

The ISM6HG256X is a high-end, low-noise, low-power 6-axis IMU, featuring a 3-axis digital low-*g* accelerometer at 16 *g*, a 3-axis digital high-*g* accelerometer at 256 *g*, and a 3-axis digital gyroscope, which offers the best IMU sensor with a quad-channel architecture for processing acceleration and angular rate data on four separate channels (user interface, OIS, EIS, and high-*g* accelerometer data) with dedicated configuration, processing, and filtering along with a dedicated high-*g* sensor for high-*g* shock.

The ISM6HG256X enables edge computing, leveraging embedded advanced dedicated features such as a finite state machine (FSM) for configurable motion tracking and a machine learning core (MLC) for context awareness with exportable AI features for IoT applications.

The device supports the adaptive self-configuration (ASC) feature, which allows automatically reconfiguring the device in real time based on the detection of a specific motion pattern or based on the output of a specific decision tree configured in the MLC, without any intervention from the host processor.

The ISM6HG256X embeds a dedicated accelerometer sensor with an independent channel and filtering for high-*g* acceleration detection that perfectly matches shock requirements for asset tracking, robotics & factory automation, condition monitoring, and worker PPE (personal protective equipment).

## 1 Overview

The ISM6HG256X is a 6-axis system-in-package featuring a high-performance 3-axis digital low-*g* accelerometer, a 3-axis digital high-*g* accelerometer, and a 3-axis digital gyroscope.

The ISM6HG256X is a smart, highly accurate IMU that simultaneously detects both low and high acceleration, ensuring reliable performance without missing any event, even in the toughest conditions of industrial applications.

The event-detection interrupts enable efficient and reliable motion tracking and context awareness, implementing hardware recognition of free-fall events, 6D orientation, activity or inactivity, stationary/motion detection and wake-up events. Machine learning and finite state machine processing allow moving some algorithms from the application processor to the ISM6HG256X sensor, enabling consistent reduction of power consumption.

The ISM6HG256X offers hardware flexibility to connect the pins with different mode connections to external sensors to expand functionalities such as adding a sensor hub, auxiliary SPI, and so forth.

Channel 1 has been designed for user interface data processing for motion tracking. Data are available on the primary output of I<sup>2</sup>C / SPI / I3C for the accelerometer and gyroscope with independent ODR and FS.

Channel 2 has been designed for OIS applications. Data are available on the auxiliary SPI or I3C at 7.68 kHz with accelerometer/gyroscope processing with independent FS at  $\pm 2\text{ g}$  to  $\pm 16\text{ g}$  (accelerometer) /  $\pm 250\text{ dps}$  to  $\pm 4000\text{ dps}$  (gyroscope). The accelerometer is also available as standalone with dedicated filtering.

Channel 3 has been designed for enhanced EIS. Data are available in free-run mode in the output registers or in FIFO with dedicated tag and timestamp.

Channel 4 has been designed for high-*g* applications with accelerometer processing with independent FS at  $\pm 32\text{ g}$  to  $\pm 256\text{ g}$ .

Up to 4.5 KB of FIFO with compression and dynamic allocation of significant data (that is, external sensors, timestamp, and so forth) allows overall power saving of the system.

The ISM6HG256X embeds a sensor fusion low-power (SFLP) algorithm able to provide a 6-axis (accelerometer + gyroscope) game rotation vector represented as a quaternion. The X, Y, Z quaternion components are stored in FIFO.

Like the entire portfolio of MEMS sensor modules, the ISM6HG256X leverages the robust and mature in-house manufacturing processes already used for the production of micromachined accelerometers and gyroscopes. The various sensing elements are manufactured using specialized micromachining processes, while the IC interfaces are developed using CMOS technology that allows the design of a dedicated circuit, which is trimmed to better match the characteristics of the sensing element.

The ISM6HG256X embeds advanced dedicated features like a finite state machine and data filtering for OIS, EIS, and motion processing.

The ISM6HG256X is available in a small plastic, land grid array (LGA) package of 2.5 x 3.0 x 0.83 mm to address ultracompact solutions.

## 2 Embedded low-power features

The ISM6HG256X features the following on-chip functions:

- 4.5 KB FIFO data buffering, data can be compressed two or three times
  - 100% efficiency with flexible configurations and partitioning
  - Possibility to store timestamp
- Event-detection interrupts (fully configurable)
  - Free-fall
  - Wake-up
  - 6D orientation
  - Click and double-click sensing
  - Activity/inactivity recognition
  - Stationary/motion detection
  - High-g wake-up and high-g shock
- Specific IP blocks (called "embedded functions") with negligible power consumption and high performance
  - Finite state machine (FSM)
  - Machine learning core (MLC) with exportable features and filters for AI applications
  - Adaptive self-configuration (ASC)
  - Embedded sensor fusion low-power (SFLP) algorithm
  - Pedometer functions: step detector and step counters
  - Tilt
  - Significant motion detection
- Sensor hub
  - Up to six total sensors: two internal (accelerometer and gyroscope) and four external sensors

## 2.1 Finite state machine

The ISM6HG256X can be configured to generate interrupt signals activated by user-defined motion patterns. To do this, up to 8 embedded finite state machines can be programmed independently for motion detection such as glance gestures, absolute wrist tilt, shake and double-shake detection.

### Definition of finite state machine

A state machine is a mathematical abstraction used to design logic connections. It is a behavioral model composed of a finite number of states and transitions between states, similar to a flow chart in which one can inspect the way logic runs when certain conditions are met. The state machine begins with a start state, goes to different states through transitions dependent on the inputs, and can finally end in a specific state (called stop state). The current state is determined by the past states of the system. The following figure shows a generic state machine.

Figure 1. Generic state machine

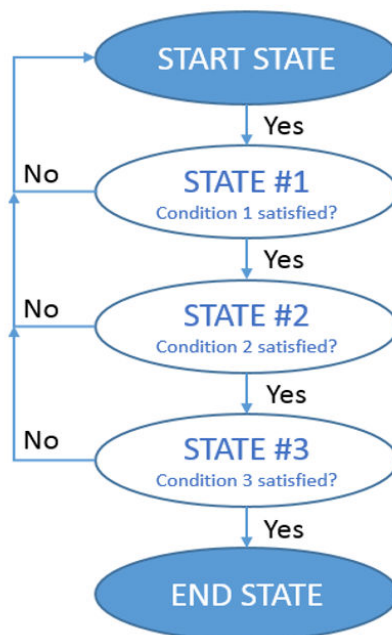

### Finite state machine in the ISM6HG256X

The ISM6HG256X works as a combo accelerometer-gyroscope sensor, generating acceleration and angular rate output data. It is also possible to connect an external sensor like a magnetometer or pressure sensor by using the sensor hub feature (mode 2). These data can be used as input of up to 8 programs in the embedded finite state machine (Figure 2. State machine in the ISM6HG256X).

All 8 finite state machines are independent: each one has its dedicated memory area and it is independently executed. An interrupt is generated when the end state is reached or when some specific command is performed.

Figure 2. State machine in the ISM6HG256X

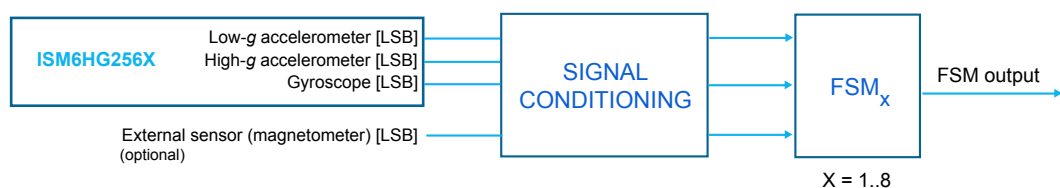

## 2.2 Machine learning core

The ISM6HG256X embeds a dedicated core for machine learning processing that provides system flexibility, allowing some algorithms run in the application processor to be moved to the MEMS sensor with the advantage of consistent reduction in power consumption.

Machine learning core logic allows identifying if a data pattern (for example motion, pressure, temperature, magnetic data, and so forth) matches a user-defined set of classes. Typical examples of applications could be activity detection like running, walking, driving, and so forth.

The ISM6HG256X machine learning core works on data patterns coming from the low-*g*, high-*g* accelerometer and gyroscope sensors, but it is also possible to connect and process external sensor data (like magnetometer or pressure sensor) by using the sensor hub feature (mode 2).

The input data can be filtered using a dedicated configurable computation block containing filters and features computed in a fixed time window defined by the user. Computed feature values and filtered data values can also be read through the FIFO buffer.

Machine learning processing is based on logical processing composed of a series of configurable nodes characterized by "if-then-else" conditions where the "feature" values are evaluated against defined thresholds.

Figure 3. Machine learning core in the ISM6HG256X

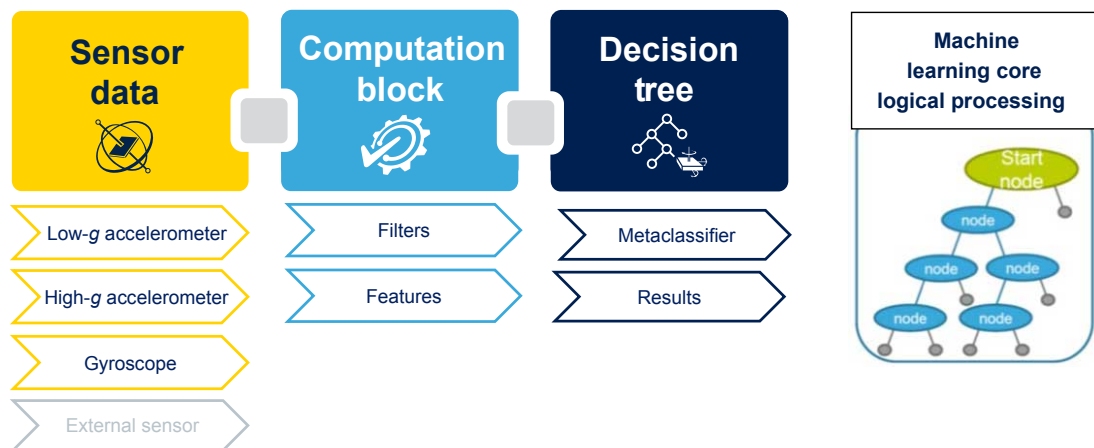

The ISM6HG256X can be configured to run up to 8 decision trees simultaneously and independently and every decision tree can generate up to 16 results. The total number of nodes can be up to 256.

The results of the machine learning processing are available in dedicated output registers readable from the application processor at any time.

The ISM6HG256X machine learning core can be configured to generate an interrupt when a change in the result occurs.

## 2.3 Adaptive self-configuration (ASC)

The ISM6HG256X supports the adaptive self-configuration (ASC) feature, which allows the FSM to automatically reconfigure the device in real time based on the detection of a specific motion pattern or based on the output of a specific decision tree configured in the MLC, without any intervention from the host processor. The FSM can write a subset of the device registers using the SETR command, which allows indicating the register address and the new value to be written in such a register. The access to these device registers is mutually exclusive to the host.

## 2.4 Sensor fusion low power

A sensor fusion low-power (SFLP) block is available in the ISM6HG256X for generating the following data based on the (low-g) accelerometer and gyroscope data processing:

- Game rotation vector, which provides a quaternion representing the attitude of the device
- Gravity vector, which provides a three-dimensional vector representing the direction of gravity
- Gyroscope bias, which provides a three-dimensional vector representing the gyroscope bias

The SFLP block is enabled by setting the SFLP\_GAME\_EN bit to 1 of the EMB\_FUNC\_EN\_A (04h) embedded functions register.

The SFLP block can be reinitialized by setting the SFLP\_GAME\_INIT bit to 1 of the EMB\_FUNC\_INIT\_A (66h) embedded functions register.

**Table 1. Sensor fusion performance**

Parameter		Value
Static accuracy	heading / yaw	0.5 deg. / 5 minutes
	pitch	1.5 deg.
	roll	1.5 deg.
Low dynamic accuracy	heading / yaw	0.7 deg. / 5 minutes
	pitch	0.5 deg.
	roll	0.5 deg.
High dynamic accuracy	heading / yaw	5.9 deg. / 5 minutes
	pitch	1.6 deg.
	roll	1.2 deg.
Calibration time		0.8 seconds <sup>(1)</sup>
Orientation stabilization time		0.7 seconds

1. Time required to reach steady state

## 2.5 Pedometer functions: step detector and step counters

The ISM6HG256X embeds an advanced pedometer with an algorithm running in an ultralow-power domain in order to ensure extensive battery life in battery-constrained applications.

Leveraging enhanced configurability, the advanced embedded pedometer is suitable for a large range of applications from mobile to wearable devices.

The algorithm processes and analyzes the accelerometer waveform in order to count the user's steps during walking and running activities.

The pedometer works at 30 Hz and it is not affected by the selected device power mode (ultralow-power, low-power, high-performance), thus guaranteeing an ultralow-power experience and extreme flexibility in conjunction with other device functionalities.

The pedometer output can be batched in the device's FIFO buffer, in order to decrease overall system supply current.

ST freely provides the support and the tools for easily configuring the device and tuning the algorithm configuration for a best-in-class user experience.

## 2.6 Pedometer algorithm

The pedometer algorithm is composed of a cascade of four stages:

1. Computation of the acceleration magnitude signal in order to detect the signal independently from device orientation;
2. FIR filter to extract relevant frequency components and to smooth the signal by cutting off high frequencies;
3. Peak detector to find the maximum and minimum of the waveform and compute the peak-to-peak value;
4. Step count: if the peak-to-peak value is greater than the settled threshold, a step is counted.

**Figure 4. Four-stage pedometer algorithm**

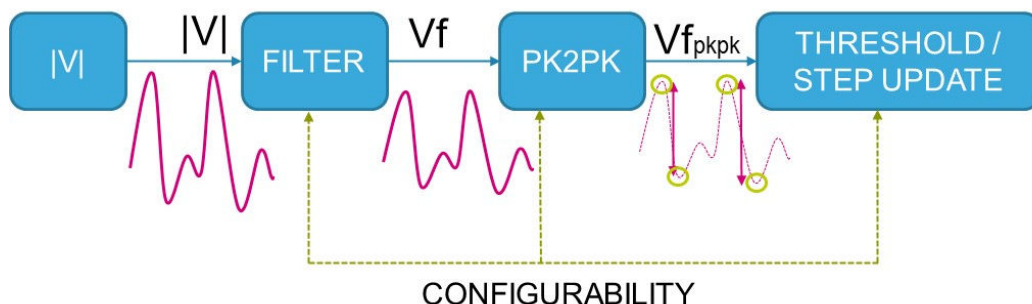

The ISM6HG256X embeds a dynamic internal threshold for step detection that is updated after each peak-to-peak evaluation: the internal threshold is increased with a configurable speed if a step is detected or decreased with a configurable speed if a step is not detected.

This approach ensures high accuracy when the user starts to walk and a false peak rejection when the user is walking or running.

An internal configurable debounce algorithm can be also set to filter false walks: indeed, an accelerometer pattern is recognized as a walk or run only if a minimum number of steps are counted.

The ISM6HG256X has been designed to reject a false-positive signal inside the algorithm core.

On top of the mechanisms detailed above, the ISM6HG256X allows enabling and configuring a dedicated false-positive rejection block to further boost pedometer accuracy.

## 2.7 Tilt detection

The tilt function helps to detect activity change and has been implemented in hardware using only the accelerometer to achieve targets of both ultralow power consumption and robustness during the short duration of dynamic accelerations.

The tilt function is based on a trigger of an event each time the device's tilt changes and can be used with different scenarios, for example:

- Triggers when a phone is in a front pants pocket and the user goes from sitting to standing or standing to sitting;
- Does not trigger when a phone is in a front pants pocket and the user is walking, running, or going upstairs.

## 2.8 Significant motion detection

The significant motion detection (SMD) function generates an interrupt when a 'significant motion', that could be due to a change in user location, is detected. In the ISM6HG256X device this function has been implemented in hardware using only the accelerometer.

SMD functionality can be used in location-based applications in order to receive a notification indicating when the user is changing location.

### 3 Pin description

Figure 5. Pin connections

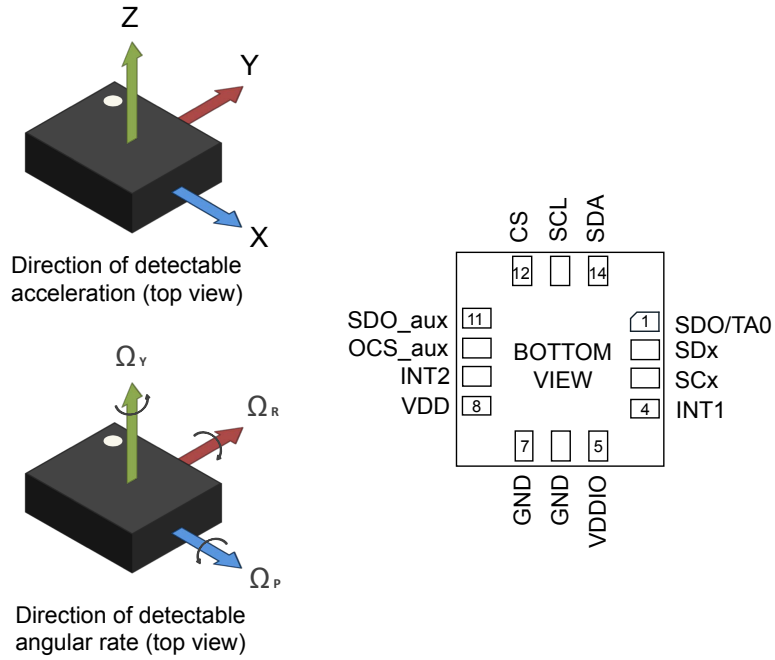

### 3.1 Pin connections

The ISM6HG256X offers flexibility to connect the pins in order to have three different mode connections and functionalities. In detail:

- **Mode 1:** I<sup>2</sup>C / MIPI I3C<sup>®</sup> target interface or SPI (3- and 4-wire) serial interface is available.
- **Mode 2:** I<sup>2</sup>C / MIPI I3C<sup>®</sup> target interface or SPI (3- and 4-wire) serial interface and I<sup>2</sup>C controller interface for external sensor connections are available.
- **Mode 3:** I<sup>2</sup>C / MIPI I3C<sup>®</sup> target interface or SPI (3- and 4-wire) serial interface is available for the application processor interface while an auxiliary MIPI I3C<sup>®</sup> / SPI (3- and 4-wire) serial interface for external sensor connections is available for the accelerometer and gyroscope.

Figure 6. ISM6HG256X connection modes

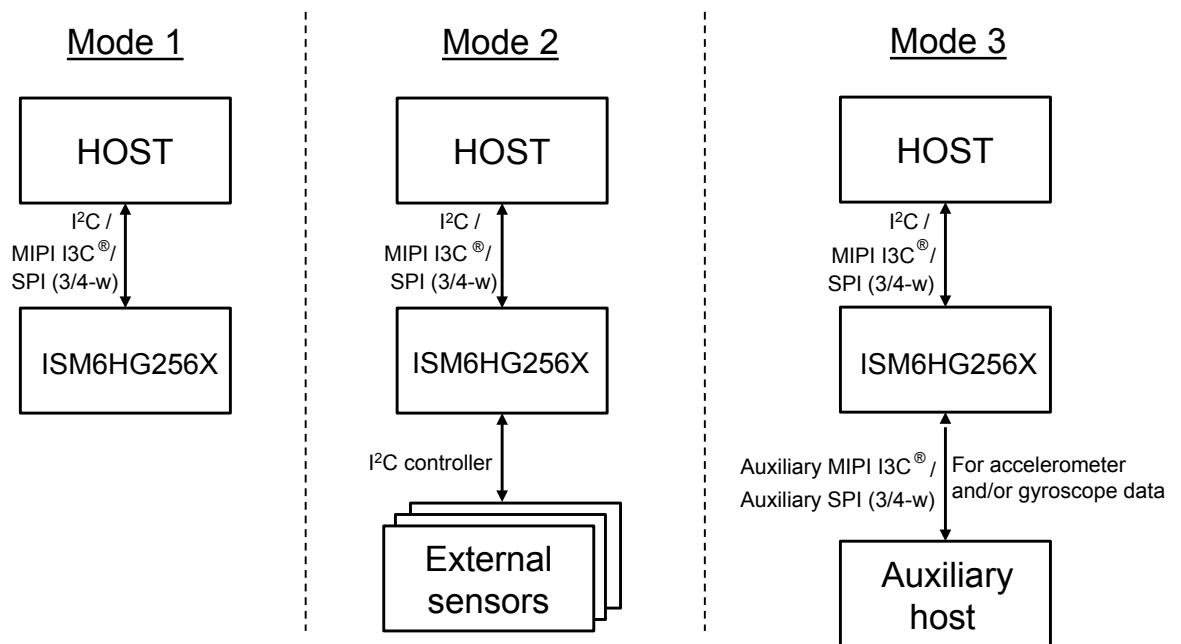

In the following table, each mode is described for the pin connections and function.

**Table 2. Pin description**

Pin#	Name	Mode 1 function	Mode 2 function	Mode 3 function
1	SDO TA0	SPI 4-wire interface serial data output (SDO) I <sup>2</sup> C least significant bit of the device address (TA0)	SPI 4-wire interface serial data output (SDO) I <sup>2</sup> C least significant bit of the device address (TA0)	SPI 4-wire interface serial data output (SDO) I <sup>2</sup> C least significant bit of the device address (TA0)
2	SDx	Connect to VDDIO or GND	I <sup>2</sup> C controller serial data (CSDA)	Auxiliary SPI 3/4-wire interface serial data input (SDI_aux) Auxiliary SPI 3-wire serial data output (SDO_aux) Auxiliary MIPI I3C <sup>®</sup> serial data (SDA_I3C_aux)
3	SCx	Connect to VDDIO or GND	I <sup>2</sup> C controller serial clock (CSCL)	Auxiliary SPI 3/4-wire interface serial port clock (SPC_aux) Auxiliary MIPI I3C <sup>®</sup> serial clock (SCL_I3C_aux)
4	INT1	Programmable interrupt in I <sup>2</sup> C and SPI		
5	VDDIO <sup>(1)</sup>	Power supply for I/O pins		
6	GND	0 V supply		
7	GND	0 V supply		
8	VDD <sup>(1)</sup>	Power supply		
9	INT2	Programmable interrupt 2 (INT2) / Data enabled (DEN)	Programmable interrupt 2 (INT2) / Data enabled (DEN) / I <sup>2</sup> C controller external synchronization signal (CDRDY)	Programmable interrupt 2 (INT2) / Data enabled (DEN)
10	OCS_aux	Connect to VDDIO or leave unconnected <sup>(2)</sup>	Connect to VDDIO or leave unconnected <sup>(2)</sup>	Auxiliary MIPI I3C <sup>®</sup> / Auxiliary SPI mode selection (1: Aux. SPI idle mode / Aux. MIPI I3C <sup>®</sup> communication enabled; 0: Aux. SPI communication mode / Aux. MIPI I3C <sup>®</sup> disabled)
11	SDO_aux	Connect to VDDIO or leave unconnected <sup>(2)</sup>	Connect to VDDIO or leave unconnected <sup>(2)</sup>	Auxiliary SPI 3-wire interface: leave unconnected <sup>(2)</sup> Auxiliary SPI 4-wire interface: serial data output (SDO_aux)
12	CS	I <sup>2</sup> C / MIPI I3C <sup>®</sup> / SPI mode selection (1: SPI idle mode / I <sup>2</sup> C / MIPI I3C <sup>®</sup> communication enabled; 0: SPI communication mode / I <sup>2</sup> C / MIPI I3C <sup>®</sup> disabled)	I <sup>2</sup> C / MIPI I3C <sup>®</sup> / SPI mode selection (1: SPI idle mode / I <sup>2</sup> C / MIPI I3C <sup>®</sup> communication enabled; 0: SPI communication mode / I <sup>2</sup> C / MIPI I3C <sup>®</sup> disabled)	I <sup>2</sup> C / MIPI I3C <sup>®</sup> / SPI mode selection (1: SPI idle mode / I <sup>2</sup> C / MIPI I3C <sup>®</sup> communication enabled; 0: SPI communication mode / I <sup>2</sup> C / MIPI I3C <sup>®</sup> disabled)
13	SCL	I <sup>2</sup> C / MIPI I3C <sup>®</sup> serial clock (SCL) SPI serial port clock (SPC)	I <sup>2</sup> C / MIPI I3C <sup>®</sup> serial clock (SCL) SPI serial port clock (SPC)	I <sup>2</sup> C / MIPI I3C <sup>®</sup> serial clock (SCL) SPI serial port clock (SPC)
14	SDA	I <sup>2</sup> C / MIPI I3C <sup>®</sup> serial data (SDA) SPI serial data input (SDI) 3-wire interface serial data output (SDO)	I <sup>2</sup> C / MIPI I3C <sup>®</sup> serial data (SDA) SPI serial data input (SDI) 3-wire interface serial data output (SDO)	I <sup>2</sup> C / MIPI I3C <sup>®</sup> serial data (SDA) SPI serial data input (SDI) 3-wire interface serial data output (SDO)

1. Recommended 100 nF filter capacitor.

2. Leave pin electrically unconnected and soldered to PCB.

## 4 Module specifications

### 4.1 Mechanical characteristics

@VDD = 1.8 V, T = 25°C, unless otherwise noted.

**Table 3. Mechanical characteristics**

Symbol	Parameter	Test conditions	Min. <sup>(1)</sup>	Typ. <sup>(2)</sup>	Max. <sup>(1)</sup>	Unit
LA_FS	Linear acceleration measurement range (low-g)			±2		g
				±4		
				±8		
				±16		
	Linear acceleration measurement range (high-g)			±32		
				±64		
				±128		
				±256		
G_FS	Angular rate measurement range			±250		dps
				±500		
				±1000		
				±2000		
LA_So	Linear acceleration sensitivity (low-g)	FS = ±2 g		0.061		mg/LSB
		FS = ±4 g		0.122		
		FS = ±8 g		0.244		
		FS = ±16 g		0.488		
	Linear acceleration sensitivity (high-g)	FS = ±32 g		0.976		mg/LSB
		FS = ±64 g		1.952		
		FS = ±128 g		3.904		
		FS = ±256 g		10.417		
G_So	Angular rate sensitivity <sup>(3)</sup>	FS = ±250 dps		8.75		mdps/LSB
		FS = ±500 dps		17.50		
		FS = ±1000 dps		35		
		FS = ±2000 dps		70		
		FS = ±4000 dps		140		
LA_So%	Linear acceleration sensitivity tolerance (low-g) <sup>(3)</sup>		-1		+1	%
	Linear acceleration sensitivity tolerance (high-g) <sup>(3)</sup>		-1		+1	
G_So%	Angular rate sensitivity tolerance <sup>(3)</sup>	at component level	-1		+1	%
LA_SoDr	Linear acceleration sensitivity change vs. temperature (low-g) <sup>(4)</sup>	from -40°C to +105°C	-0.005	±0.001	+0.005	%°C
	Linear acceleration sensitivity change vs. temperature (high-g) <sup>(4)</sup>	from -40°C to +105°C	-0.02	±0.01	+0.02	
G_SoDr	Angular rate sensitivity change vs. temperature <sup>(4)</sup>	from -40°C to +105°C	-0.01	±0.005	+0.01	%°C
LA_TyOff	Linear acceleration zero-g level offset accuracy (low-g) <sup>(5)</sup>		-65	±10	+65	mg

Symbol	Parameter	Test conditions	Min. <sup>(1)</sup>	Typ. <sup>(2)</sup>	Max. <sup>(1)</sup>	Unit
LA_TyOff	Linear acceleration zero-g level offset accuracy (high-g) <sup>(5)</sup>		-1000	±250	+1000	mg
G_TyOff	Angular rate zero-rate level <sup>(5)</sup>		-2	±0.5	+2	dps
LA_TCOFF	Linear acceleration zero-g level change vs. temperature (low-g) <sup>(4)</sup>	from -40 to +105°C	-0.4	±0.15	+0.4	mg/°C
	Linear acceleration zero-g level change vs. temperature (high-g) <sup>(4)</sup>	from -40 to +105°C	-5	±2	+5	
G_TCOFF	Angular rate typical zero-rate level change vs. temperature <sup>(4)</sup>	from -40 to +105°C	-0.015	±0.006	+0.015	dps/°C
NL	Nonlinearity (high-g) <sup>(6)</sup>	FS = ±256 g		2		%FS
Rn	Rate noise density in high-performance mode <sup>(7)</sup>	FS = ±250 dps - ±4000 dps		4.5	5.5	mdps/√Hz
BI	Bias instability <sup>(6)</sup>	T = 25°C		3		°/h
An	Acceleration noise density in high-performance mode (low-g) <sup>(8)</sup>	FS = ±2 g - ±16 g		65	100	μg/√Hz
	Acceleration noise density in high-performance mode (high-g)	FS = ±32 g - ±256 g		1000	1100	
	Acceleration noise density in normal mode (low-g) <sup>(9)(10)</sup>	FS = ±2 g - ±16 g		110		
RMS	Accelerometer RMS noise in low-power mode (low-g)	LPM1		2.7		mg RMS
		LPM2		2.1		
		LPM3		1.5		
LA_ODR	Linear acceleration output data rate (low-g)			1.875 <sup>(11)</sup>		Hz
				7.5		
				15		
				30		
				60		
				120		
				240		
				480		
				960		
				1.92 k		
3.84 k						
7.68 k						
G_ODR	Angular rate output data rate			7.5		Hz
				15		
				30		
				60		
				120		
				240		
				480		
				960		
				1.92 k		
				3.84 k		
7.68 k						
HAODR	ODR variation over temperature and supply range in high-accuracy mode <sup>(12)</sup>	Gyro on			±1	%
		Gyro off			±3	
LA_F0	Accelerometer resonant frequency (low-g)	X, Y-axis		2.65		kHz
		Z-axis		2.4		

Symbol	Parameter	Test conditions	Min. <sup>(1)</sup>	Typ. <sup>(2)</sup>	Max. <sup>(1)</sup>	Unit
LA_F0	Accelerometer resonant frequency (high-g)	X, Y-axis Z-axis		9.2 7.5		kHz
G_F0	Gyroscope resonant frequency			23		kHz
LA_BW	Linear acceleration signal bandwidth (low-g) <sup>(6)</sup>	±3 dB point	0.6			kHz
	Linear acceleration signal bandwidth (high-g) <sup>(6)</sup>	±3 dB point		2		
Vst	Linear acceleration self-test output change (low-g) <sup>(13)(14)(15)</sup>		50		1700	mg
	Linear acceleration self-test output change (high-g) <sup>(13)(14)(15)</sup>		150		2500	mg
	Angular rate self-test output change <sup>(16)(17)</sup>	FS = ±250 dps	20		80	dps
		FS = ±4000 dps	150		700	dps
Top	Operating temperature range		-40		+105	°C

1. Min/Max values are based on characterization results at 3 $\sigma$  on a limited number of samples, not tested in production and not guaranteed.
2. Typical specifications are not guaranteed.
3. Sensitivity values after factory calibration test and trimming in socket
4. Measurements are performed in a uniform temperature setup and they are based on characterization data in a limited number of samples. Not measured during final test for production and not guaranteed.
5. Values after factory calibration test and trimming in socket
6. Typical values, based on characterization results on a limited number of samples, not tested in production and not guaranteed
7. Gyroscope rate noise density in high-performance mode is independent of the ODR and FS setting
8. Accelerometer noise density in high-performance mode is independent of the selected ODR and FS.
9. Accelerometer noise density in normal mode is independent of the ODR and FS setting.
10. Noise RMS related to BW = ODR/2.
11. This ODR is available when the accelerometer is in low-power mode.
12. Values specified by design.
13. The sign of the linear acceleration self-test output change is defined by the ST\_XL[1:0] bits in a dedicated register for all axes.
14. The linear acceleration self-test output change is defined with the device in stationary condition as the absolute value of: OUTPUT[LSB] (self-test enabled) - OUTPUT[LSB] (self-test disabled). 1LSB = 0.061 mg at ±2 g full scale.
15. Accelerometer self-test limits are full-scale independent.
16. The sign of the angular rate self-test output change is defined by the ST\_G[1:0] bits in a dedicated register for all axes.
17. The angular rate self-test output change is defined with the device in stationary condition as the absolute value of: OUTPUT[LSB] (self-test enabled) - OUTPUT[LSB] (self-test disabled). 1LSB = 140 mdps at ±4000 dps full scale.

## 4.2 Electrical characteristics

@VDD = 1.8 V, T = 25°C, unless otherwise noted.

**Table 4. Electrical characteristics**

Symbol	Parameter	Test conditions	Min. <sup>(1)</sup>	Typ. <sup>(2)</sup>	Max. <sup>(1)</sup>	Unit
VDD	Supply voltage		1.71	1.8	3.6	V
VDDIO	Power supply for I/O		1.08		3.6	V
IddHP	Gyroscope and low-g accelerometer supply current in high-performance mode			0.670		mA
IddHPC9	Gyroscope and accelerometer supply current in high-performance mode	Combo: gyroscope, low-g & high-g accelerometer		0.8		mA
LA_IddHP	Accelerometer supply current in high-performance mode (low-g)			200		μA
	Accelerometer supply current in high-performance mode (high-g)			225		
LA_IddNM	Accelerometer supply current in normal mode (low-g)			115		μA
LA_IddLPM2	Accelerometer supply current in low-power mode (LPM2) (low-g)	ODR = 60 Hz		21		μA
		ODR = 1.875 Hz		4.6		
LA_IddLPM1	Accelerometer supply current in low-power mode (LPM1) (low-g)	ODR = 60 Hz		18		μA
		ODR = 1.875 Hz		4.5		
IddPD	Supply current during power-down			2.9		μA
Ton	Turn-on time - gyroscope			40		ms
VIH	Digital high-level input voltage	VDDIO = 1.8 V (typ)		0.7 * VDDIO		V
		VDDIO = 1.2 V (typ)		0.8 * VDDIO		
VIL	Digital low-level input voltage	VDDIO = 1.8 V (typ)			0.3 * VDDIO	V
		VDDIO = 1.2 V (typ)			0.2 * VDDIO	
VOH	High-level output voltage	VDDIO = 1.8 V IOH = 4 mA <sup>(3)</sup>		VDDIO - 0.2		V
		VDDIO = 1.2 V IOH = 2 mA <sup>(3)</sup>		VDDIO - 0.2		
VOL	Low-level output voltage	VDDIO = 1.2 V IOL = 4 mA <sup>(3)</sup>			0.2	V
		VDDIO = 1.8 V IOL = 2 mA <sup>(3)</sup>			0.2	
Top	Operating temperature range		-40		+105	°C

1. Min/Max values are based on characterization results at 3σ on a limited number of samples, not tested in production and not guaranteed.
2. Typical specifications are not guaranteed.
3. 4 mA is the maximum driving capability, that is, the maximum DC current that can be sourced/sunk by the digital pin in order to guarantee the correct digital output voltage levels VOH and VOL.

### 4.3 Temperature sensor characteristics

@VDD = 1.8 V, T = 25°C unless otherwise noted.

**Table 5. Temperature sensor characteristics**

Symbol	Parameter	Test condition	Min. <sup>(1)</sup>	Typ. <sup>(2)</sup>	Max. <sup>(1)</sup>	Unit
TODR <sup>(3)</sup>	Temperature refresh rate			60		Hz
Toff	Temperature offset <sup>(4)</sup>		-15		+15	°C
TSen	Temperature sensitivity			256		LSB/°C
TST	Temperature stabilization time <sup>(5)</sup>				500	µs
T_ADC_res	Temperature ADC resolution			16		bit
Top	Operating temperature range		-40		+105	°C

1. Min/Max values are based on characterization results at 3σ on a limited number of samples, not tested in production and not guaranteed.
2. Typical specifications are not guaranteed
3. When the accelerometer is in low-power mode and the gyroscope part is turned off, the TODR value is equal to the accelerometer ODR.
4. The output of the temperature sensor is 0 LSB (typ.) at 25°C.
5. Time from power ON to valid data based on characterization data.

## 4.4 Communication interface characteristics

### 4.4.1 SPI - serial peripheral interface

Subject to general operating conditions for VDD and Top. @VDDIO = 1.8 V, T = 25°C unless otherwise noted.

**Table 6. SPI target timing values (VDDIO at 1.8 V)**

Symbol	Parameter	Value <sup>(1)</sup>			Unit	
		Min	Typ	Max		
$f_{c(SPC)}$	SPI clock frequency			10	MHz	
$t_{c(SPC)}$	SPI clock period	100			ns	
$t_{high(SPC)}$	SPI clock high	45				
$t_{low(SPC)}$	SPI clock low	45				
$t_{su(CS)}$	CS setup time (mode 3)	5				
	CS setup time (mode 0)	20				
$t_h(CS)$	CS hold time (mode 3)	20				
	CS hold time (mode 0)	20				
$t_{su(SI)}$	SDI input setup time	5				
$t_h(SI)$	SDI input hold time	15				
$t_v(SO)$	SDO valid output time		15	25		
$t_{dis(SO)}$	SDO output disable time			50		
$C_{load}$	Bus capacitance			100		pF

1. Values are evaluated at 10 MHz clock frequency for SPI with both 4 and 3 wires, based on characterization results, not tested in production

Subject to general operating conditions for VDD and Top. @VDDIO = 1.2 V, T = 25°C unless otherwise noted.

**Table 7. SPI target timing values (VDDIO at 1.2 V)**

Symbol	Parameter	Value			Unit	
		Min	Typ	Max		
$f_{c(SPC)}$	SPI clock frequency			10	MHz	
$t_{c(SPC)}$	SPI clock period	100			ns	
$t_{high(SPC)}$	SPI clock high	45				
$t_{low(SPC)}$	SPI clock low	45				
$t_{su(CS)}$	CS setup time (mode 3)	25				
	CS setup time (mode 0)	50				
$t_h(CS)$	CS hold time (mode 3)	50				
	CS hold time (mode 0)	50				
$t_{su(SI)}$	SDI input setup time	15				
$t_h(SI)$	SDI input hold time	30				
$t_v(SO)$	SDO valid output time			30		
$t_{dis(SO)}$	SDO output disable time			50		
$C_{load}$	Bus capacitance			50		pF

Figure 7. SPI target timing in mode 0

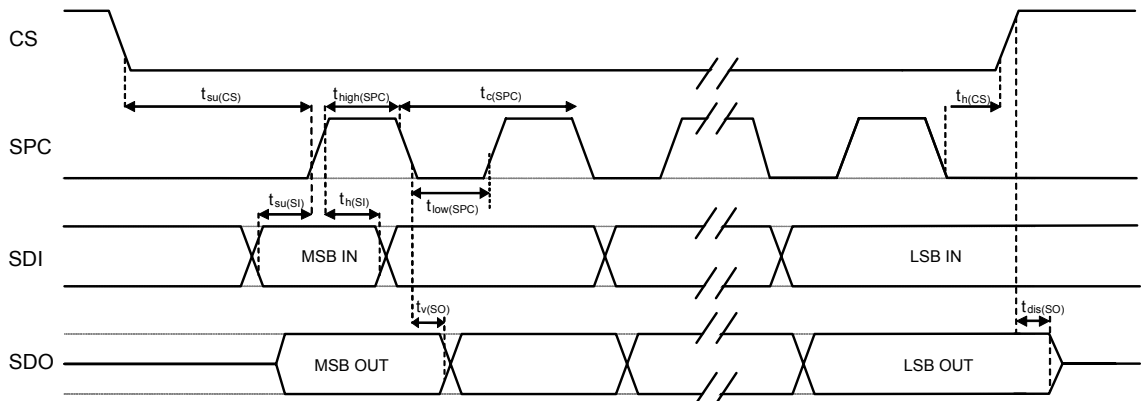
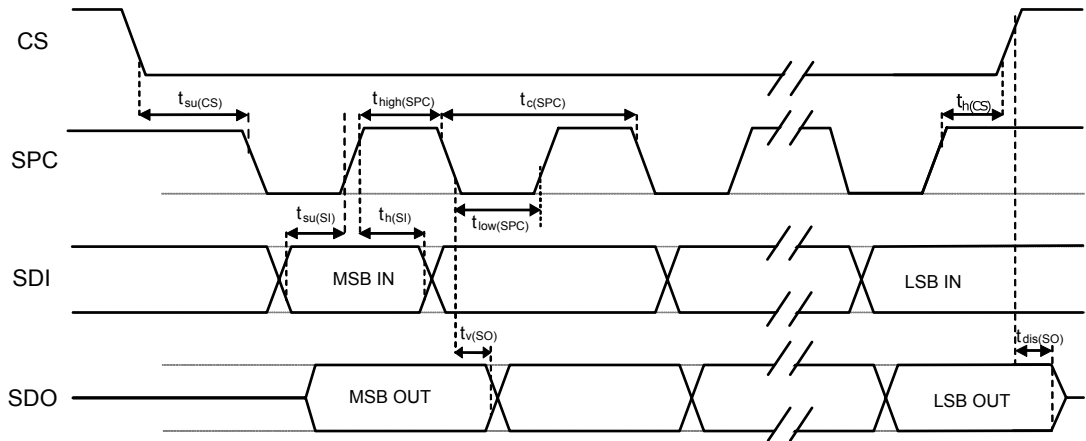

Figure 8. SPI target timing in mode 3



Note: Measurement points are done at  $0.3 \cdot VDDIO$  and  $0.7 \cdot VDDIO$  for both input and output ports.

#### 4.4.2 I<sup>2</sup>C - inter-IC control interface

Subject to general operating conditions for VDD and Top. @VDDIO = 1.8 V, T = 25°C unless otherwise noted.

**Table 8. I<sup>2</sup>C target timing values**

Symbol	Parameter	I <sup>2</sup> C fast mode <sup>(1)(2)</sup>		I <sup>2</sup> C fast mode plus <sup>(1)(2)</sup>		Unit
		Min	Max	Min	Max	
f <sub>(SCL)</sub>	SCL clock frequency	0	400	0	1000	kHz
t <sub>w(SCLL)</sub>	SCL clock low time	1.3		0.5		μs
t <sub>w(SCLH)</sub>	SCL clock high time	0.6		0.26		
t <sub>su(SDA)</sub>	SDA setup time	100		50		ns
t <sub>h(SDA)</sub>	SDA data hold time	0	0.9	0		μs
t <sub>h(ST)</sub>	START/REPEATED START condition hold time	0.6		0.26		
t <sub>su(SR)</sub>	REPEATED START condition setup time	0.6		0.26		
t <sub>su(SP)</sub>	STOP condition setup time	0.6		0.26		
t <sub>w(SP:SR)</sub>	Bus free time between STOP and START condition	1.3		0.5		
	Data valid time		0.9		0.45	
	Data valid acknowledge time		0.9		0.45	
C <sub>B</sub>	Capacitive load for each bus line		400		550 <sup>(3)</sup>	pF

1. Data based on standard I<sup>2</sup>C protocol requirement, not tested in production.
2. Data for I<sup>2</sup>C fast mode and I<sup>2</sup>C fast mode plus have been validated by characterization, not tested in production.
3. Maximum capacitive load if VDDIO ≥ 1.62 V. If VDDIO < 1.62 V, the maximum load must be reduced to 400 pF.

**Figure 9. I<sup>2</sup>C target timing diagram**

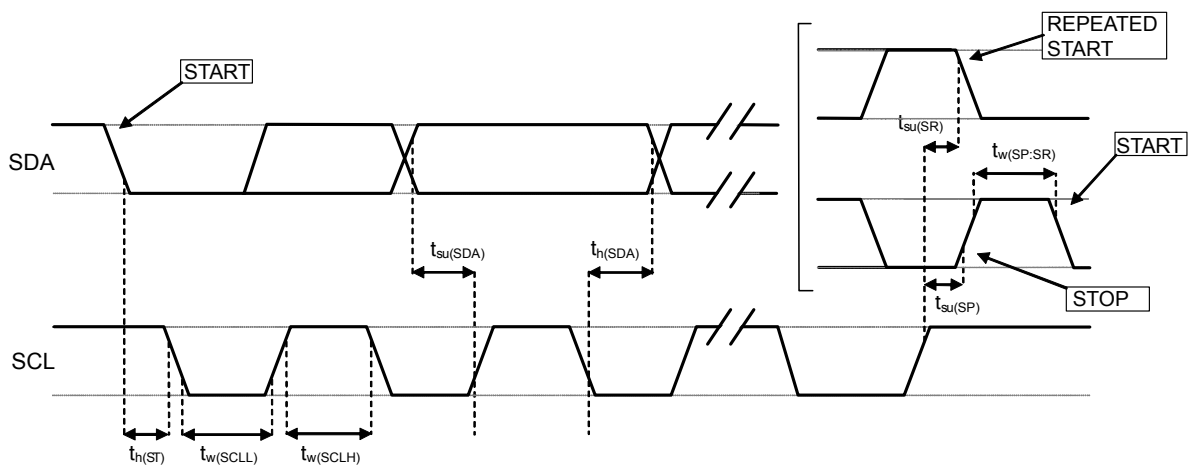

**Note:** Measurement points are done at 0.3·VDDIO and 0.7·VDDIO for both ports.

## 4.5 Absolute maximum ratings

Stresses above those listed as “absolute maximum ratings” may cause permanent damage to the device. This is a stress rating only and functional operation of the device under these conditions is not implied. Exposure to maximum rating conditions for extended periods may affect device reliability.

**Table 9. Absolute maximum ratings**

Symbol	Ratings	Maximum value	Unit
VDD	Supply voltage	-0.3 to +4.8	V
T <sub>STG</sub>	Storage temperature range	-40 to +125	°C
Sg	Acceleration <i>g</i> for 0.2 ms	20,000	<i>g</i>
R <sub>shocks</sub>	Repetitive shocks at acceleration above measurable full scale	100,000 shocks @ 300 <i>g</i> for 0.5 ms	<i>g</i>
ESD	Electrostatic discharge protection (HBM)	2	kV
V <sub>in</sub>	Input voltage on any control pin (including CS, SCL/SPC, SDA/SDI/SDO, SDO/TA0)	-0.3 to VDDIO +0.3	V

*Note:* Supply voltage on any pin should never exceed 4.8 V.



This device is sensitive to mechanical shock, improper handling can cause permanent damage to the part.



This device is sensitive to electrostatic discharge (ESD), improper handling can cause permanent damage to the part.

## 4.6 Terminology

### 4.6.1 Sensitivity

Linear acceleration sensitivity can be determined, for example, by applying 1 g acceleration to the device. Because the sensor can measure DC accelerations, this can be done easily by pointing the selected axis towards the ground, noting the output value, rotating the sensor 180 degrees (pointing towards the sky) and noting the output value again. By doing so,  $\pm 1$  g acceleration is applied to the sensor. Subtracting the larger output value from the smaller one, and dividing the result by 2, leads to the actual sensitivity of the sensor. This value changes very little over temperature and over time. The sensitivity tolerance describes the range of sensitivities of a large number of sensors (see [Table 3](#)).

An angular rate gyroscope is a device that produces a positive-going digital output for counterclockwise rotation around the axis considered. Sensitivity describes the gain of the sensor and can be determined by applying a defined angular velocity to it. This value changes very little over temperature and time (see [Table 3](#)).

### 4.6.2 Zero-g and zero-rate level

Linear acceleration zero-g level offset (TyOff) describes the deviation of an actual output signal from the ideal output signal if no acceleration is present. A sensor in a steady state on a horizontal surface measures 0 g on both the X-axis and Y-axis, whereas the Z-axis measures 1 g. Ideally, the output is in the middle of the dynamic range of the sensor (content of OUT registers 00h, data expressed as two's complement number). A deviation from the ideal value in this case is called zero-g offset.

Offset is to some extent a result of stress to the MEMS sensor and therefore the offset can slightly change after mounting the sensor onto a printed circuit board or exposing it to extensive mechanical stress. Offset changes little over temperature, see "Linear acceleration zero-g level change vs. temperature" in [Table 3](#). The zero-g level tolerance (TyOff) describes the standard deviation of the range of zero-g levels of a group of sensors.

Zero-rate level describes the actual output signal if there is no angular rate present. The zero-rate level of precise MEMS sensors is, to some extent, a result of stress to the sensor and therefore the zero-rate level can slightly change after mounting the sensor onto a printed circuit board or after exposing it to extensive mechanical stress. This value changes very little over temperature and time (see [Table 3](#)).

## 5 Digital interfaces

### 5.1 I<sup>2</sup>C/SPI interface

The registers embedded inside the ISM6HG256X may be accessed through both the I<sup>2</sup>C and SPI serial interfaces. The latter may be software configured to operate either in 3-wire or 4-wire interface mode. The device is compatible with SPI modes 0 and 3.

The serial interfaces are mapped to the same pins. To select/exploit the I<sup>2</sup>C interface, the CS line must be tied high (that is, connected to VDDIO).

**Table 10. Serial interface pin description**

Pin name	Pin description
CS	Enables SPI I <sup>2</sup> C/SPI mode selection (1: SPI idle mode / I <sup>2</sup> C communication enabled; 0: SPI communication mode / I <sup>2</sup> C disabled)
SCL/SPC	I <sup>2</sup> C serial clock (SCL) SPI serial port clock (SPC)
SDA/SDI/SDO	I <sup>2</sup> C serial data (SDA) SPI serial data input (SDI) 3-wire interface serial data output (SDO)
SDO/TA0	SPI serial data output (SDO) I <sup>2</sup> C less significant bit of the device address

#### 5.1.1 I<sup>2</sup>C serial interface

The ISM6HG256X I<sup>2</sup>C is a bus target. The I<sup>2</sup>C is employed to write the data to the registers, whose content can also be read back.

The relevant I<sup>2</sup>C terminology is provided in the table below.

**Table 11. I<sup>2</sup>C terminology**

Term	Description
Transmitter	The device that sends data to the bus
Receiver	The device that receives data from the bus
Controller	The device that initiates a transfer, generates clock signals, and terminates a transfer
Target	The device addressed by the controller

There are two signals associated with the I<sup>2</sup>C bus: the serial clock line (SCL) and the serial data line (SDA). The latter is a bidirectional line used for sending and receiving the data to/from the interface. Both the lines must be connected to VDDIO through external pull-up resistors. When the bus is free, both the lines are high.

The I<sup>2</sup>C interface is implemented with fast mode (400 kHz) I<sup>2</sup>C standards as well as with fast mode plus (1000 kHz).

In order to disable the I<sup>2</sup>C block, I2C\_I3C\_disable = 1 must be written in IF\_CFG (03h).

### 5.1.2 I<sup>2</sup>C operation

The transaction on the bus is started through a start (ST) signal. A start condition is defined as a high to low transition on the data line while the SCL line is held high. After this has been transmitted by the controller, the bus is considered busy. The next byte of data transmitted after the start condition contains the address of the target in the first 7 bits and the eighth bit tells whether the controller is receiving data from the target or transmitting data to the target. When an address is sent, each device in the system compares the first seven bits after a start condition with its address. If they match, the device considers itself addressed by the controller.

The target address (TAD) associated to the ISM6HG256X is 110101xb. The SDO/TA0 pin can be used to modify the less significant bit of the device address. If the SDO/TA0 pin is connected to the supply voltage, LSb is 1 (address 1101011b); else if the SDO/TA0 pin is connected to ground, the LSb value is 0 (address 1101010b). This solution permits to connect and address two different inertial modules to the same I<sup>2</sup>C bus.

Data transfer with acknowledge is mandatory. The transmitter must release the SDA line during the acknowledge pulse. The receiver must then pull the data line low so that it remains stable low during the high period of the acknowledge clock pulse. A receiver that has been addressed is obliged to generate an acknowledge after each byte of data received.

The I<sup>2</sup>C embedded inside the ISM6HG256X behaves like a target device and the following protocol must be adhered to. After the start condition (ST) a target address is sent, once a target acknowledge (TAK) has been returned, an 8-bit subaddress (SUB) is transmitted. The increment of the address is configured by the CTRL3 (12h) (IF\_INC).

The target address is completed with a read/write bit. If the bit is 1 (read), a repeated start (SR) condition must be issued after the two subaddress bytes; if the bit is 0 (write) the controller transmits to the target with direction unchanged. Table 12 explains how the TAD+read/write bit pattern is composed, listing all the possible configurations.

**Table 12. TAD+read/write patterns**

Command	TAD[6:1]	TAD[0] = TA0	R/W	TAD+R/W
Read	110101	0	1	11010101 (D5h)
Write	110101	0	0	11010100 (D4h)
Read	110101	1	1	11010111 (D7h)
Write	110101	1	0	11010110 (D6h)

**Table 13. Transfer when controller is writing one byte to target**

Controller	ST	SAD + W		SUB		DATA		SP
Target			TAK		TAK		TAK	

**Table 14. Transfer when controller is writing multiple bytes to target**

Controller	ST	TAD + W		SUB		DATA		DATA		SP
Target			TAK		TAK		TAK		TAK	

**Table 15. Transfer when controller is receiving (reading) one byte of data from target**

Controller	ST	TAD + W		SUB		SR	TAD + R			NCAK	SP
Target			TAK		TAK			TAK	DATA		

**Table 16. Transfer when controller is receiving (reading) multiple bytes of data from target**

Controller	ST	SAD+W		SUB		SR	SAD+R			MAK		MAK		NMAK	SP
Target			TAK		TAK			TAK	DATA		DATA		DATA		

Data are transmitted in byte format (DATA). Each data transfer contains 8 bits. The number of bytes transferred per transfer is unlimited. Data is transferred with the most significant bit (MSb) first. If a target receiver does not acknowledge the target address (that is, it is not able to receive because it is performing some real-time function) the data line must be left high by the target. The controller can then abort the transfer. A low to high transition on the SDA line while the SCL line is high is defined as a stop condition. Each data transfer must be terminated by the generation of a stop (SP) condition.

In the presented communication format, CAK is controller acknowledge and NCAK is no controller acknowledge.

### 5.1.3 SPI bus interface

The SPI on the ISM6HG256X is a bus target that allows writing and reading the registers of the device.

**Figure 10. Read and write protocol (in mode 3)**

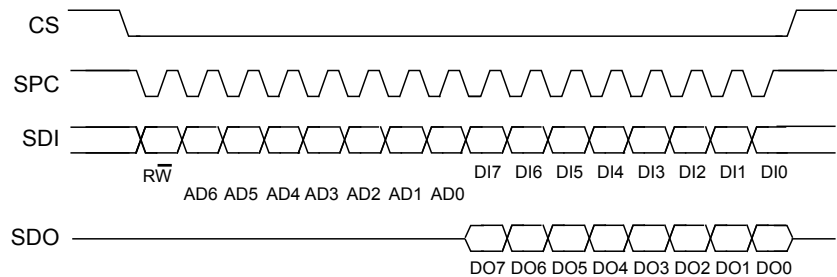

**CS** enables the serial port and it is controlled by the SPI controller. It goes low at the start of the transmission and goes back high at the end. **SPC** is the serial port clock and it is controlled by the SPI controller. It is stopped high when **CS** is high (no transmission). **SDI** and **SDO** are, respectively, the serial port data input and output. Those lines are driven at the falling edge of **SPC** and should be captured at the rising edge of **SPC**.

Both the read register and write register commands are completed in 16 clock pulses or in multiples of 8 in the case of multiple read/write bytes. Bit duration is the time between two falling edges of **SPC**. The first bit (bit 0) starts at the first falling edge of **SPC** after the falling edge of **CS** while the last bit (bit 15, bit 23, ...) starts at the last falling edge of **SPC** just before the rising edge of **CS**.

**bit 0:**  $\overline{RW}$  bit. When 0, the data  $DI(7:0)$  is written into the device. When 1, the data  $DO(7:0)$  from the device is read. In the latter case, the chip drives **SDO** at the start of bit 8.

**bit 1-7:** address  $AD(6:0)$ . This is the address field of the indexed register.

**bit 8-15:** data  $DI(7:0)$  (write mode). This is the data that is written into the device (MSb first).

**bit 8-15:** data  $DO(7:0)$  (read mode). This is the data that is read from the device (MSb first).

In multiple read/write commands further blocks of 8 clock periods are added. When the **CTRL3 (12h) (IF\_INC)** bit is 0, the address used to read/write data remains the same for every block. When the **CTRL3 (12h) (IF\_INC)** bit is 1, the address used to read/write data is increased at every block.

The function and the behavior of **SDI** and **SDO** remain unchanged.

5.1.3.1 SPI read

Figure 11. SPI read protocol (in mode 3)

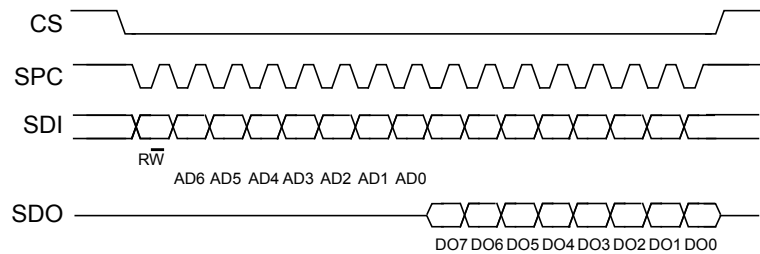

The SPI read command is performed with 16 clock pulses. A multiple byte read command is performed by adding blocks of 8 clock pulses to the previous one.

**bit 0:** READ bit. The value is 1.

**bit 1-7:** address AD(6:0). This is the address field of the indexed register.

**bit 8-15:** data DO(7:0) (read mode). This is the data that is read from the device (MSb first).

**bit 16-...:** data DO(...-8). Further data in multiple byte reads.

Figure 12. Multiple byte SPI read protocol (2-byte example) (in mode 3)

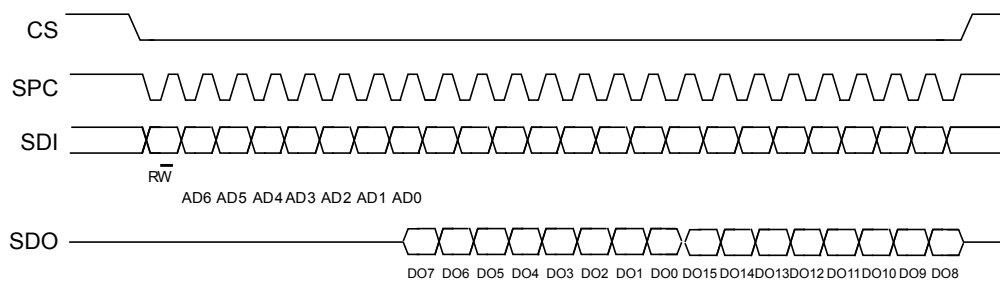

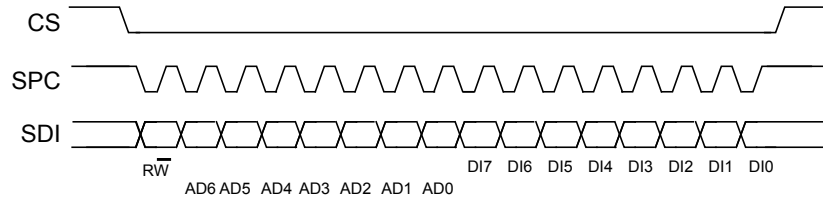
**5.1.3.2 SPI write**
**Figure 13. SPI write protocol (in mode 3)**

The SPI write command is performed with 16 clock pulses. A multiple byte write command is performed by adding blocks of 8 clock pulses to the previous one.

**bit 0:** WRITE bit. The value is 0.

**bit 1 -7:** address AD(6:0). This is the address field of the indexed register.

**bit 8-15:** data DI(7:0) (write mode). This is the data that is written inside the device (MSb first).

**bit 16-...** : data DI(...-8). Further data in multiple byte writes.

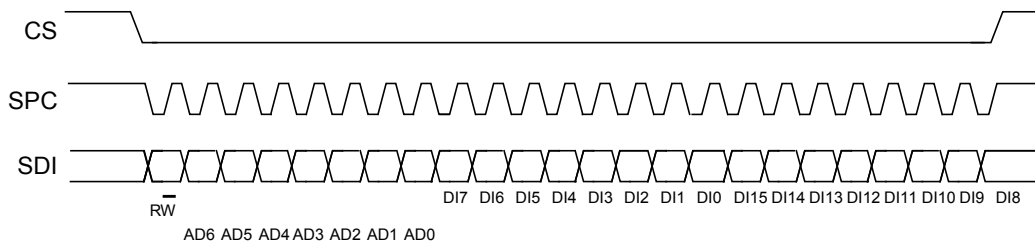
**Figure 14. Multiple byte SPI write protocol (2-byte example) (in mode 3)**

**5.1.3.3 SPI read in 3-wire mode**

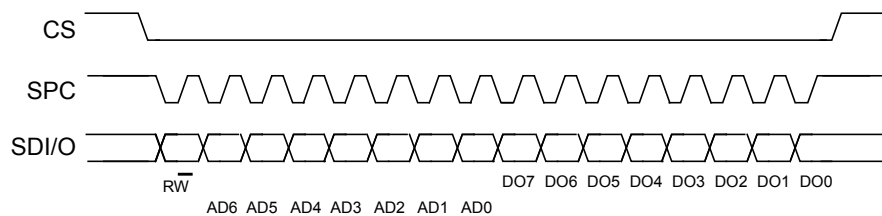
3-wire mode is entered by setting the IF\_CFG (03h) (SIM) bit equal to 1 (SPI serial interface mode selection).

**Figure 15. SPI read protocol in 3-wire mode (in mode 3)**

The SPI read command is performed with 16 clock pulses:

**bit 0:** READ bit. The value is 1.

**bit 1-7:** address AD(6:0). This is the address field of the indexed register.

**bit 8-15:** data DO(7:0) (read mode). This is the data that is read from the device (MSb first).

A multiple read command is also available in 3-wire mode.

## 5.2 MIPI I3C<sup>®</sup> interface

### 5.2.1 MIPI I3C<sup>®</sup> target interface

The ISM6HG256X interface includes a MIPI I3C<sup>®</sup> SDR-only target interface (compliant with release 1.1 of the specification) with MIPI I3C<sup>®</sup> SDR embedded features:

- CCC command
- Direct CCC communication (SET and GET)
- Broadcast CCC communication
- Private communications
- Private read and write for single byte
- Multiple read and write
- In-band interrupt request
- Target reset pattern
- Group address
- Full range VDDIO support
- Asynchronous modes 0 and 1
- Synchronous mode
- Error detection and recovery methods (S0-S6)

In order to disable the MIPI I3C<sup>®</sup> block, I2C\_I3C\_disable = 1 must be written in IF\_CFG (03h).

### 5.2.2 MIPI I3C<sup>®</sup> CCC supported commands

The list of MIPI I3C<sup>®</sup> CCC commands supported by the device is detailed in the following table.

**Table 17. MIPI I3C<sup>®</sup> CCC commands**

Command	Command code	Default	Description
ENTDAA	0x07		DAA procedure
SETDASA	0x87		Assign dynamic address using static address 0x6B/0x6A depending on SDO pin
ENEC	0x80 / 0x00		Target activity control (direct and broadcast)
DISEC	0x81 / 0x01		Target activity control (direct and broadcast)
ENTAS0	0x82 / 0x02		Enter activity state (direct and broadcast)
SETXTIME	0x98 / 0x28		Timing information exchange
GETXTIME	0x99	0x07 0x00 0x06 0x92	Timing information exchange
RSTDAA	0x06		Reset the assigned dynamic address (broadcast only)
SETMWL	0x89 / 0x08		Define maximum write length during private write (direct and broadcast)
SETMRL	0x8A / 0x09		Define maximum read length during private read (direct and broadcast)
SETNEWDA	0x88		Change dynamic address
GETMWL	0x8B	0x00 0x08 (2 byte)	Get maximum write length during private write
GETMRL	0x8C	0x00 0x10 0x0A	Get maximum read length during private read

Command	Command code	Default	Description
		(3 byte)	
GETPID	0x8D	0x02 0x08 0x00 0x73 0x92 0x0B	SDO = 1
		0x02 0x08 0x00 0x73 0x12 0x0B	SDO = 0
GETBCR	0x8E	0x27 (1 byte)	Bus characteristics register
GETDCR	0x8F	0x44 default	MIPI I3C <sup>®</sup> device characteristics register
GETSTATUS	0x90	0x00 0x00 (2 byte)	Status register
GETMXDS	0x94	0x08 0x60	Return max write and read speed
GETCAPS	0x95	0x00 0x11 0x18 0x00	Provide information about device capabilities and supported extended features
SETGRPA	0x9B		Group address assignment command
RSTGRPA	0x2C / 0x9C		Reset the group address
RSTACT	0x9A / 0x2A		Configure target reset action

### 5.2.3 Overview of antispike filter management

The device acts as a standard I<sup>2</sup>C target as long as it has an I<sup>2</sup>C static address. The device is capable of detecting and disabling the I<sup>2</sup>C antispike filter after detecting the broadcast address (7'h7E/W). In order to guarantee proper behavior of the device, the I3C controller must emit the first START, 7'h7E/W at open-drain speed using I<sup>2</sup>C fast mode plus reference timing.

After detecting the broadcast address, the device can receive the I3C dynamic address following the I3C push-pull timing. If the device is not assigned a dynamic address, then the device continues to operate as an I<sup>2</sup>C device with no antispike filter. For the case in which the host decides to keep the device as I<sup>2</sup>C with an antispike filter, there is a configuration required to keep the antispike filter active. This configuration is done by writing the ASF\_CTRL bit to 1 in the IF\_CFG (03h) register. This configuration forces the antispike filter to always be turned on instead of being managed by the communication on the bus.

### 5.3 Auxiliary MIPI I3C<sup>®</sup> target interface

The ISM6HG256X interface includes an auxiliary MIPI I3C<sup>®</sup> SDR-only target interface (compliant with release 1.1 of the specification) with MIPI I3C<sup>®</sup> SDR embedded features:

- CCC command
- Direct CCC communication (SET and GET)
- Broadcast CCC communication
- Private communications
- Private read and write for single byte
- Multiple read and write
- In-band interrupt request
- Target reset pattern (peripheral reset only)
- Group address
- Full range VDDIO support
- Error detection and recovery methods (S0-S6)

In order to disable the MIPI I3C<sup>®</sup> auxiliary block, AUX\_SPI\_READ\_EN = 1 must be written in IF2\_CTRL1\_OIS (70h)

**Table 18. MIPI I3C<sup>®</sup> CCC commands**

Command	Command code	Default	Description
ENTDAA	0x07		DAA procedure
SETDASA	0x87		Assign dynamic address using static address 0x6C/0x6D depending on the AUX_PID(TA0_AUX) bit in CTRL5 (14h)
ENEC	0x80/0x00		Target activity control (direct and broadcast)
DISEC	0x81/0x01		Target activity control (direct and broadcast)
ENTAS0	0x82/0x02		Enter activity state (direct and broadcast)
RSTDAA	0x06		Reset the assigned dynamic address (broadcast only)
SETMWL	0x89/0x08		Define maximum write length during private write (direct and broadcast)
SETMRL	0x8A/0x09		Define maximum read length during private read (direct and broadcast)
SETNEWDA	0x88		Change dynamic address
GETMWL	0x8B	0x00 0x08 (2 byte)	Get maximum write length during private write
GETMRL	0x8C	0x00 0x10 0x0D (3 byte)	Get maximum read length during private read
GETPID	0x8D	0x02 0x08 0x00 0x73 0xB2 0x0B	AUX_PID = 1 in CTRL5 (14h)
		0x02 0x08 0x00 0x73	AUX_PID = 0 in CTRL5 (14h)

Command	Command code	Default	Description
GETPID	0x8D	0xA2 0x0B	
GETBCR	0x8E	0x27	Bus characteristics register
GETDCR	0x8F	0x44	MIPI I3C <sup>®</sup> device characteristics register
GETSTATUS	0x90	0x00 0x00 (2 byte)	Status register
GETMXDS	0x94	0x08 0x60	Return max write and read speed
GETCAPS	0x95	0x00 0x11 0x18 0x00	Provide information about device capabilities and supported extended features
SETGRPA	0x9B		Group address assignment command
RSTGRPA	0x2C/0x9C		Reset the group address
RSTACT	0x9A/0x2A		Configure target reset action

## 5.4 Auxiliary SPI interface

If the ISM6HG256X is configured in mode 3, the auxiliary SPI is available. The auxiliary SPI interface is mapped to the following dedicated pins.

**Table 19. Auxiliary SPI pin details**

Pin name	Pin description
OCS_Aux	Enables auxiliary SPI 3/4-wire
SDx	Auxiliary SPI 3/4-wire data input (SDI_Aux) and SPI 3-wire data output (SDO_Aux)
SCx	Auxiliary SPI 3/4-wire interface serial port clock
SDO_Aux	Auxiliary SPI 4-wire data output (SDO_Aux)

When the ISM6HG256X is configured in mode 3, the auxiliary SPI can be connected to an auxiliary host for OIS or other stabilization application support.

## 5.5 I<sup>2</sup>C controller interface

If the ISM6HG256X is configured in mode 2, an I<sup>2</sup>C controller line is available. The controller serial interface is mapped to the following dedicated pins.

**Table 20. I<sup>2</sup>C controller pin details**

Pin name	Pin description
CSCL	I <sup>2</sup> C controller serial clock
CSDA	I <sup>2</sup> C controller serial data
CDRDY	I <sup>2</sup> C controller external synchronization signal

## 6 Functionality

This section describes all the operating modes and power modes of the ISM6HG256X.

*Note:* Refer to the product application note for the details regarding operating/power mode configurations, settings, turn-on/off time and on-the-fly changes.

### 6.1 Operating modes

In the ISM6HG256X, the low-*g*, high-*g* accelerometers and the gyroscope can be turned on/off independently of each other and are allowed to have different ODRs and power modes.

### 6.2 Low-*g* accelerometer

In the ISM6HG256X, the accelerometer can be configured in six different operating modes: power-down mode, low-power mode (1, 2, 3), normal mode, high-performance mode, high-accuracy ODR mode, and ODR-triggered mode.

The operating mode selected depends on the value of the OP\_MODE\_XL\_[2:0] bits in CTRL1 (10h).

If the value of the OP\_MODE\_XL\_[2:0] bits is 000 (default), high-performance mode is valid for all ODRs (from 7.5 Hz up to 7.68 kHz).

Normal mode is available for ODR values from 7.5 Hz to 1.92 kHz and it is enabled by setting the OP\_MODE\_XL\_[2:0] bits to 111. Normal mode cannot be used in mode 3 connection mode.

In high-performance mode and in normal mode, the analog antialiasing filter is active.

Low-power mode is available for lower ODRs (1.875 Hz, 15 Hz, 30 Hz, 60 Hz, 120 Hz, 240 Hz). The three low-power modes are enabled by setting OP\_MODE\_XL\_[2:0] to 100 (LPM1), 101 (LPM2), 110 (LPM3).

High-accuracy ODR mode is available for ODR values from 15 Hz up to 7.68 kHz and it is enabled by setting the OP\_MODE\_XL\_[2:0] bits to 001. Refer to Section 6.5: High-accuracy ODR mode for more details.

ODR-triggered mode is available for ODR values from 15 Hz up to 7.68 kHz and it is enabled by setting the OP\_MODE\_XL\_[2:0] bits to 011. Refer to Section 6.6: ODR-triggered mode for more details.

The embedded functions based on accelerometer data (free-fall, 6D/4D, tap/double-tap, wake-up, activity/inactivity, stationary/motion, step counter, step detection, significant motion, tilt) and the FIFO batching functionality are supported in all modes.

**Figure 16. Single-channel mode (XL\_DualC\_EN = 0)**

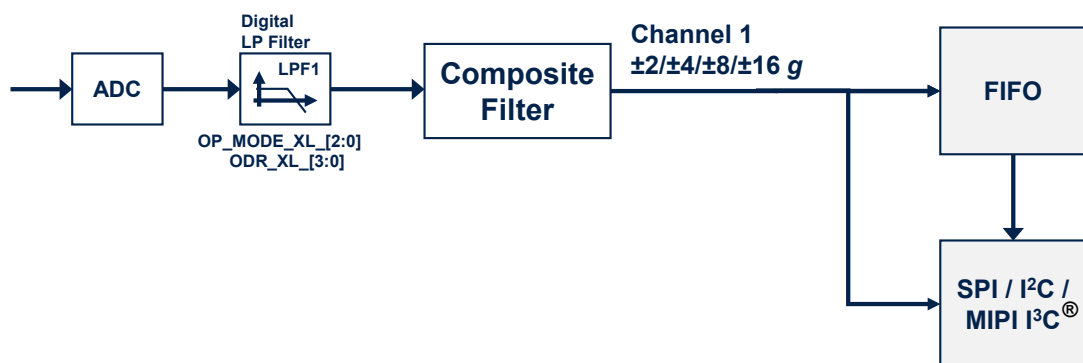

### 6.3 High-g accelerometer

In the ISM6HG256X, the high-g accelerometer can be configured with different ODRs from 480 Hz up to 7.68 kHz.

When the high-g accelerometer is used, the low-g accelerometer must be configured in high-performance mode or in high-accuracy ODR mode. In these configurations, antialiasing is enabled. The ODRs are independent between the low-g and high-g accelerometers.

There are no limitations on the selectable operating mode of the gyroscope when the high-g channel is enabled.

**Table 21. High-g accelerometer compatibility with low-g accelerometer operating modes and ODRs**

Low-g accelerometer modes	Low-g accelerometer ODR_XL	High-g compatibility
High-performance	All	Y
High-accuracy ODR	All	Y
Low-power	All	N
Normal mode	All	N
ODR-triggered	All	N

**Figure 17. High-g accelerometer filter**

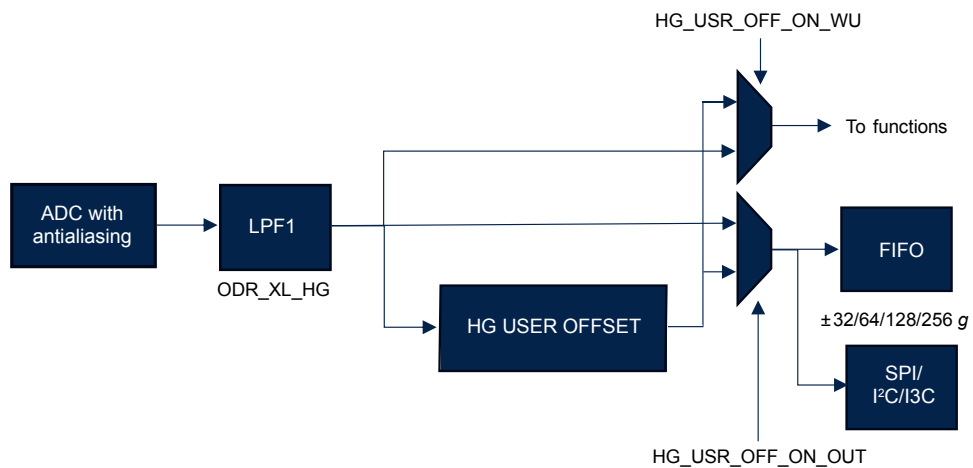

## 6.4 Gyroscope power modes

In the ISM6HG256X, the gyroscope can be configured in six different operating modes: power-down mode, sleep mode, low-power mode, high-performance mode, high-accuracy ODR mode, and ODR-triggered mode.

The operating mode selected depends on the value of the OP\_MODE\_G\_[2:0] bits in CTRL2 (11h).

If the value of the OP\_MODE\_G\_[2:0] bits is 000 (default), high-performance mode is valid for all ODRs (from 7.5 Hz up to 7.68 kHz).

Low-power mode is available for lower ODRs (7.5 Hz, 15 Hz, 30 Hz, 60 Hz, 120 Hz, 240 Hz) and it is enabled by setting the OP\_MODE\_G\_[2:0] bits to 101.

High-accuracy ODR mode is available for ODR values from 15 Hz up to 7.68 kHz and it is enabled by setting the OP\_MODE\_G\_[2:0] bits to 001. Refer to Section 6.5: High-accuracy ODR mode for more details.

ODR-triggered mode is available for ODR values from 15 Hz up to 7.68 kHz and it is enabled by setting the OP\_MODE\_XL\_[2:0] bits to 011. Refer to Section 6.6: ODR-triggered mode for more details.

## 6.5 High-accuracy ODR mode

High-accuracy ODR (HAODR) mode can be enabled to reduce the part-to-part output data rate variation. It supports both the low-*g*, high-*g* accelerometers and the gyroscope. When this mode is used for one sensor (accelerometers or gyroscope), the other sensor also has to be configured in high-accuracy ODR (HAODR) mode.

The main high-accuracy ODR features are:

- Noise level is aligned with high-performance mode
- The power consumption in HAODR mode depends on the selected ODR and on the enabled sensors. As an example, at ODR = 960 Hz in combo mode (accelerometer + gyroscope) it increases 20  $\mu$ A (typical) compared to high-performance mode. Refer to the application note for more details.
- The UI channel bandwidth can be selected through the gyroscope LPF1 and accelerometer HPF/LPF2 filters.
- When HAODR mode is enabled, it is applied to the UI low-*g*, high-*g* accelerometers, UI gyroscope, EIS gyroscope, and temperature. It is not applied to the OIS accelerometer/gyroscope channels.

*Note:* HAODR mode has to be enabled / disabled when the device is in power-down mode.

When HAODR mode is enabled, four different sets of ODRs are supported based on the configuration of the HAODR\_SEL\_[1:0] bitfield in the HAODR\_CFG (62h) register, as shown in the table below.

*Note:* High-accuracy ODR mode is not compatible with the activity/inactivity functionality (motion/stationary can be used).

**Table 22. Accelerometer and gyroscope ODR selection in high-accuracy ODR mode**

ODR_XL_[3:0] ODR_G_[3:0]	ODR [Hz] HAODR_SEL_[1:0] = 00	ODR [Hz] HAODR_SEL_[1:0] = 01	ODR [Hz] HAODR_SEL_[1:0] = 10	ODR [Hz] HAODR_SEL_[1:0] = 11
0000	Power-down	Power-down	Power-down	Power-down
0001	Reserved	Reserved	Reserved	Reserved
0010	Reserved	Reserved	Reserved	Reserved
0011	15	15.625	12.5	13
0100	30	31.25	25	26
0101	60	62.5	50	52
0110	120	125	100	104
0111	240	250	200	208
1000	480	500	400	417
1001	960	1000	800	833
1010	1920	2000	1600	1667
1011	3840	4000	3200	3333
1100	7680	8000	6400	6667
Others	Reserved	Reserved	Reserved	Reserved

## 6.6 ODR-triggered mode

When ODR-triggered mode is enabled, a reference signal must be provided to the INT2 pin, and the device then automatically aligns (in frequency and phase) the data generation to the edges of the reference signal.

It supports the low-*g* accelerometer only, gyroscope only, and the combo of low-*g* accelerometer and gyroscope. When both the accelerometer and gyroscope are enabled, the user must configure the same ODR on both the accelerometer and gyroscope. It is not possible to select different ODRs for the accelerometer and gyroscope; if different output data rate values are set, the ODR configured for the gyroscope data is also applied to the accelerometer data.

The full-scale configurations are totally independent between the accelerometer and gyroscope and they can be set in any combination.

*Note:* ODR-triggered mode has to be enabled / disabled when the device is in power-down mode.

*Note:* When ODR-triggered mode is enabled, the 1100 configuration of the ODR\_XL\_[3:0] bits in register CTRL1 (10h) and the 1100 configuration of the ODR\_G\_[3:0] bits in register CTRL2 (11h) cannot be used.

*Note:* ODR-triggered mode is not compatible with the EIS functionality.

## 6.7 Block diagram of filters

Figure 18. Block diagram of filters

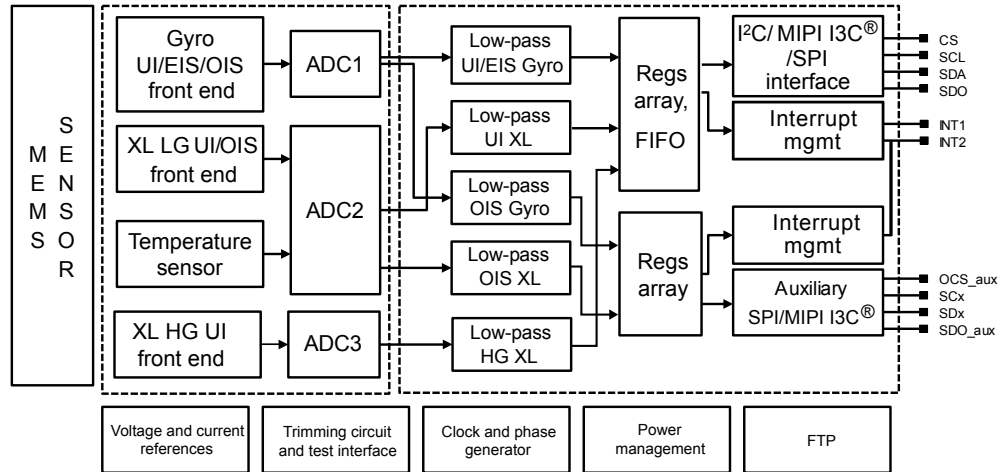

### 6.7.1 Block diagrams of the low-g accelerometer filters

In the ISM6HG256X, the filtering chain for the accelerometer part is composed of the following:

- Digital filter (LPF1)
- Composite filter

Details of the block diagram appear in the following figure.

Figure 19. Low-g accelerometer UI chain

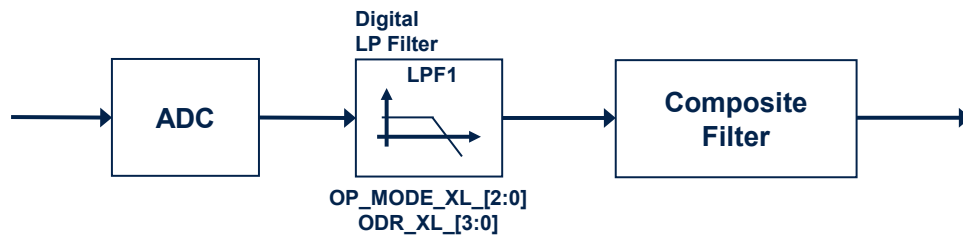
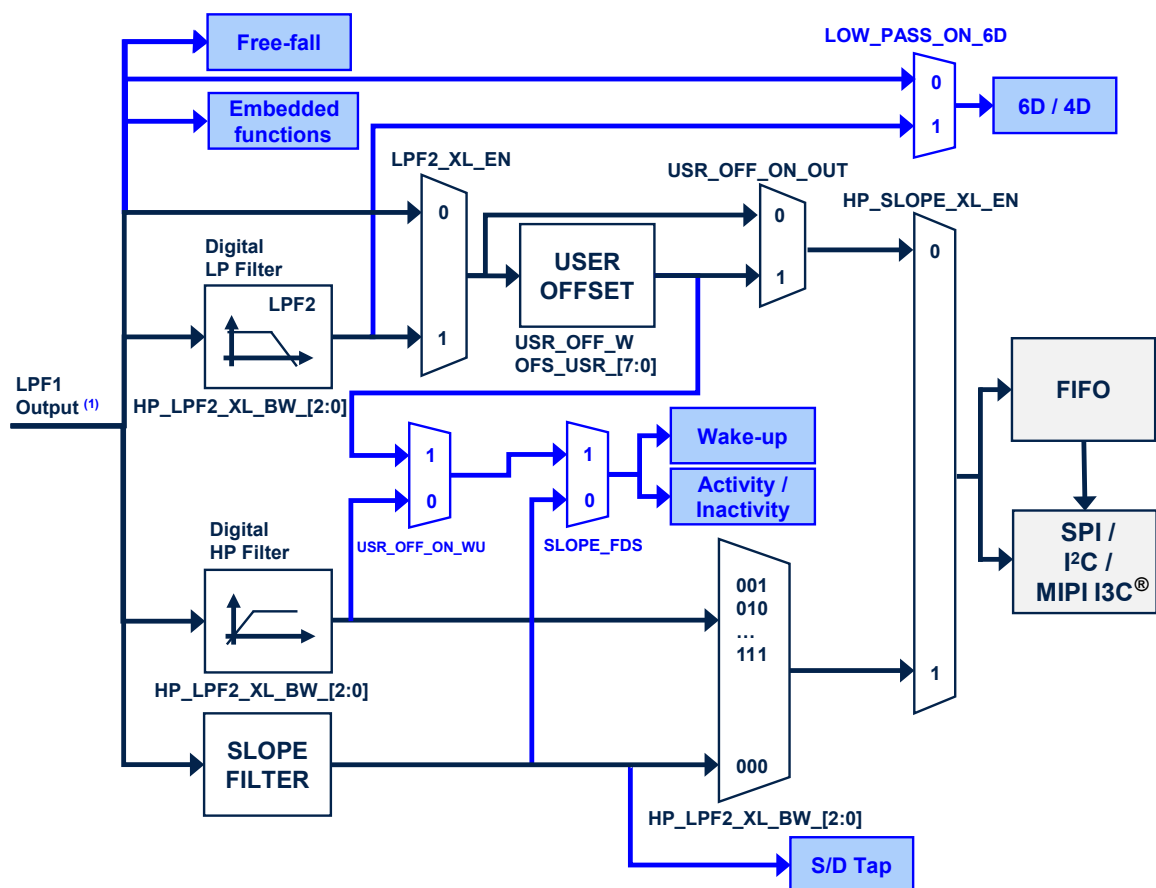

Figure 20. Low-g accelerometer composite filter



1. The cutoff value of the LPF1 output is  $ODR/2$  when the accelerometer is in high-performance mode, high-accuracy ODR mode, or normal mode. This value is equal to 2300 Hz when the accelerometer is in low-power mode 1 (2 mean), 912 Hz in low-power mode 2 (4 mean) or 431 Hz in low-power mode 3 (8 mean).

Note: Embedded functions include finite state machine, machine learning core, pedometer, step detector and step counter, significant motion detection, and tilt functions.

The accelerometer filtering chain when mode 3 is enabled is illustrated in the following figure.

**Figure 21. Accelerometer chain with mode 3 enabled**

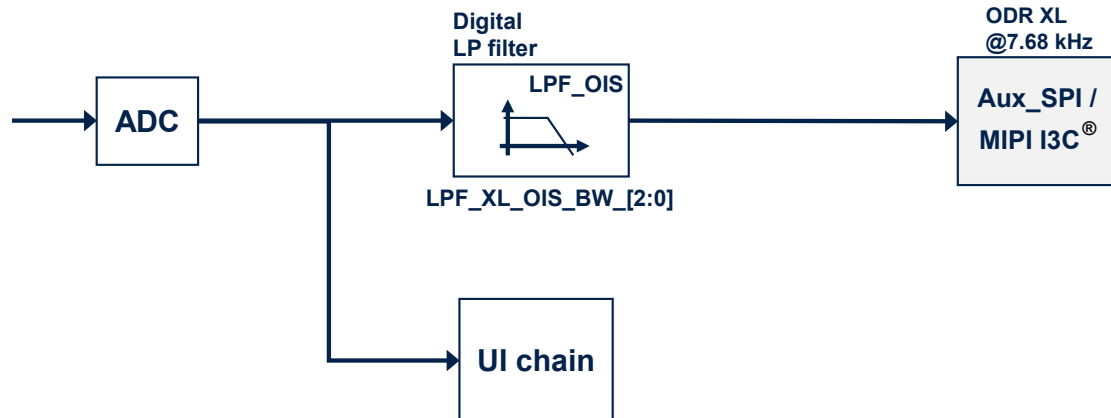

**Note:** The accelerometer OIS chain is enabled by setting the OIS\_XL\_EN bit to 1 in the UI\_CTRL1\_OIS (70h) / IF2\_CTRL1\_OIS (70h) register.

The configuration of the accelerometer UI chain is not affected by enabling/disabling the accelerometer OIS chain, with one exception: accelerometer normal operating mode (OP\_MODE\_XL\_[2:0] = 111 in the CTRL1 (10h) register) cannot be used when the accelerometer OIS chain is enabled.

Accelerometer output values are available in the following registers with ODR at 7.68 kHz:

- UI\_OUTX\_L\_A\_OIS\_HG (34h) and UI\_OUTX\_H\_A\_OIS\_HG (35h) through UI\_OUTZ\_L\_A\_OIS\_HG (38h) and UI\_OUTZ\_H\_A\_OIS\_HG (39h)
- IF2\_OUTX\_L\_A\_OIS (28h) and IF2\_OUTX\_H\_A\_OIS (29h) through IF2\_OUTZ\_L\_A\_OIS (2Ch) and IF2\_OUTZ\_H\_A\_OIS (2Dh)

**Note:** When the accelerometer OIS is used, refer to the product application note for the power mode configuration and settings.

### 6.7.2 Block diagrams of the gyroscope filters

In the ISM6HG256X, the gyroscope filtering chain depends on the mode configuration:

- Mode 1 (for user interface (UI) and electronic image stabilization (EIS) functionality through the primary interface) and mode 2

**Figure 22. Gyroscope digital chain - mode 1 (UI/EIS) and mode 2**

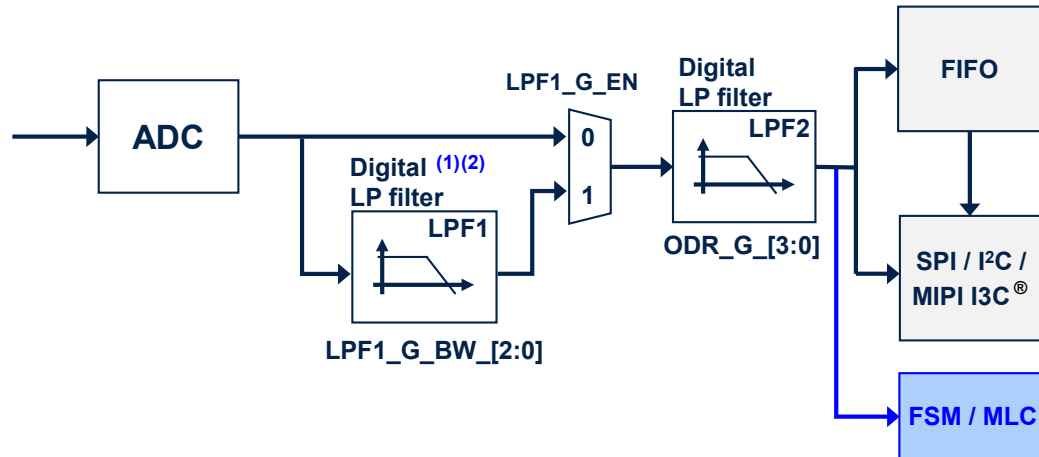

1. When the gyroscope OIS or EIS chain is enabled, the LPF1 filter is not available in the gyroscope UI chain. It is recommended to avoid using the LPF1 filter in the gyroscope UI chain when the gyroscope OIS or EIS is used.
2. The LPF1 filter is available in high-performance mode only. If the gyroscope is configured in low-power mode, the LPF1 filter is bypassed.

In this configuration, the gyroscope ODR is selectable from 7.5 Hz up to 7.68 kHz. A low-pass filter (LPF1) is available, for more details about the filter characteristics see [Table 66. Gyroscope LPF1 + LPF2 bandwidth selection](#).

The digital LPF2 filter's cutoff frequency depends on the selected gyroscope ODR, as indicated in the following table.

**Table 23. Gyroscope LPF2 bandwidth selection**

Gyroscope ODR [Hz]	LPF2 cutoff [Hz]
7.5	3.4
15	6.6
30	13.0
60	24.6
120	49.4
240	96
480	187
960	342
1.92 kHz	491
3.84 kHz	528
7.68 kHz	537

*Note:* Data can be acquired from the output registers and FIFO over the primary I<sup>2</sup>C/MIPI I3C<sup>®</sup>/SPI interface.

- Mode 3 (for OIS functionality)

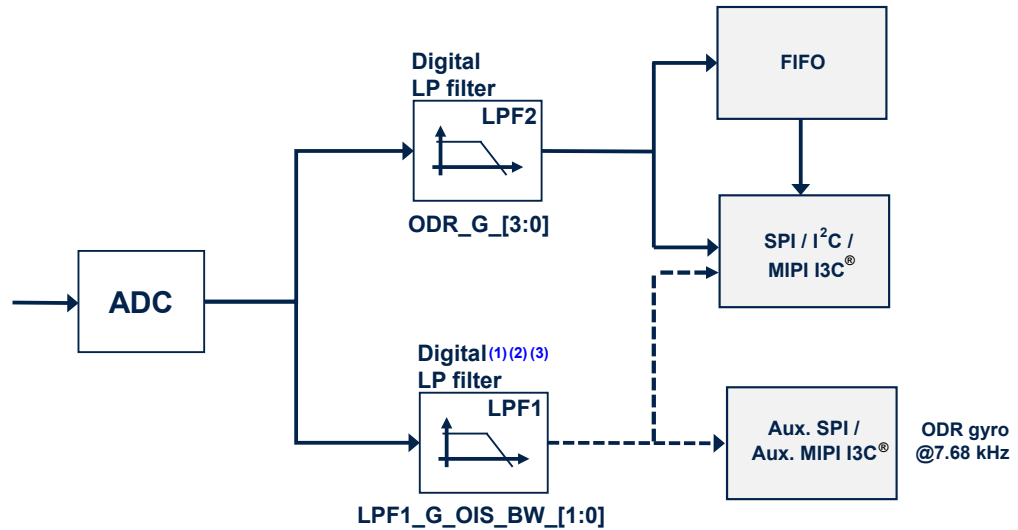
**Figure 23. Gyroscope digital chain - mode 3 (OIS)**

1. When the gyroscope OIS or EIS chain is enabled, the LPF1 filter is not available in the gyroscope UI chain.
2. It is recommended to avoid using the LPF1 filter in mode 1/2 when the gyroscope OIS or EIS chain is used.
3. When the gyroscope OIS is used, refer to the product application note for the power mode configuration and settings.

The auxiliary interface needs to be enabled in [UI\\_CTRL1\\_OIS \(70h\)](#) / [IF2\\_CTRL1\\_OIS \(70h\)](#).

In mode 3 configuration, there are two paths:

- The chain for user interface (UI) where the ODR is selectable from 7.5 Hz up to 7.68 kHz
- The chain for OIS where the ODR is at 7.68 kHz and the LPF1 is available. The LPF1 configuration depends on the setting of the LPF1\_G\_OIS\_BW\_[1:0] bits in register [UI\\_CTRL2\\_OIS \(71h\)](#) / [IF2\\_CTRL2\\_OIS \(71h\)](#); for more details about the filter characteristics see [UI\\_CTRL2\\_OIS \(71h\)](#). Gyroscope output values are in registers 22h to 27h if read from the auxiliary interfaces or in registers 2Eh to 33h if read from the primary interface with the selected full scale FS\_G\_OIS\_[1:0] bits in [UI\\_CTRL2\\_OIS \(71h\)](#) / [IF2\\_CTRL2\\_OIS \(71h\)](#).

## 6.8 Enhanced EIS

The ISM6HG256X offers advanced design flexibility for EIS applications: enhanced EIS functionality has a dedicated channel and processing with independent filtering.

Enhanced EIS main features:

- Enhanced EIS channel gyroscope data can be read over the primary interfaces through I<sup>2</sup>C / MIPI I3C<sup>®</sup> / SPI.
- EIS data are available in free-run mode in the output registers (UI\_OUTX\_L\_G\_OIS\_EIS (2Eh) and UI\_OUTX\_H\_G\_OIS\_EIS (2Fh) through UI\_OUTZ\_L\_G\_OIS\_EIS (32h) and UI\_OUTZ\_H\_G\_OIS\_EIS (33h)) by setting the G\_EIS\_ON\_G\_OIS\_OUT\_REG bit to 1 in the CTRL\_EIS (6Bh) register or in FIFO (by setting the G\_EIS\_FIFO\_EN bit to 1 in the FIFO\_CTRL4 (0Ah) register) with dedicated TAG and timestamp configurable using FIFO\_CTRL4 (0Ah).
- Enhanced EIS option is compatible with mode 3 selection. When EIS data-out are read from the output registers (setting G\_EIS\_ON\_G\_OIS\_OUT\_REG bit), data from the gyroscope OIS chain can be only read from the auxiliary interfaces.

**Figure 24. ISM6HG256X supports UI, enhanced EIS, and OIS processing simultaneously**

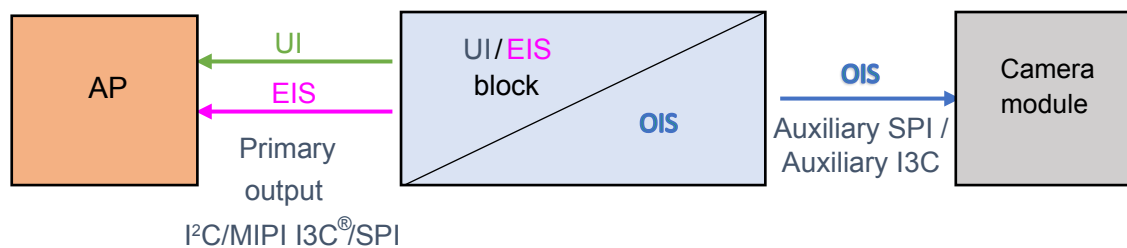

**Figure 25. Gyroscope enhanced EIS and UI block diagram**

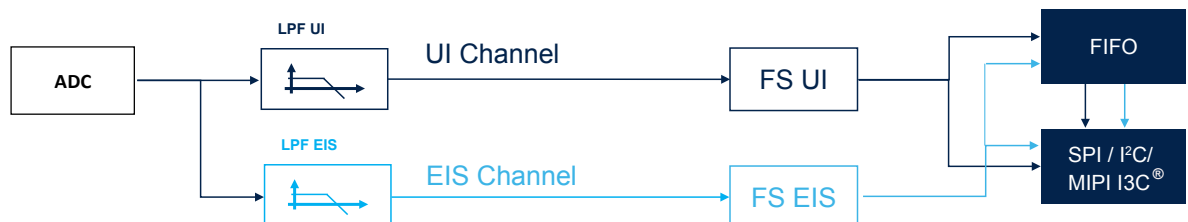

When enhanced EIS mode is activated through the ODR\_EIS\_[1:0] bits in the CTRL\_EIS (6Bh) register:

- Gyroscope UI can be configured only in power-down mode, high-performance mode, or high-accuracy ODR mode.
- Gyroscope EIS full scale can be selected by using the FS\_G\_EIS\_[2:0] bits in the CTRL\_EIS (6Bh) register.
- Gyroscope EIS data rate selectable at 1.92 kHz or 960 Hz configurable through the ODR\_G\_EIS\_[1:0] bits in the CTRL\_EIS (6Bh) register.
- LPF\_EIS low-pass filter (refer to Figure 25) bandwidth selection can be configured through the LPF\_G\_EIS\_BW bit in the CTRL\_EIS (6Bh) register.

## 6.9 OIS

This section describes OIS functionality. There is a dedicated gyroscope and accelerometer DSP for OIS. The device also supports self-test functionality on the OIS side.

### 6.9.1 Enabling OIS functionality and configuration options

There are two different ways in order to enable and configure the OIS functionality:

- **Auxiliary interface full control:** enabling and configuration done from the auxiliary SPI / MIPI I3C®
- **Primary interface full control:** enabling and configuration done from the primary interface

The configurations that allow selecting these two different options are done using the OIS\_CTRL\_FROM\_UI bit in the FUNC\_CFG\_ACCESS (01h) register as described in the following table.

**Table 24. OIS configurations**

OIS_CTRL_FROM_UI	OIS configuration option
0	Auxiliary SPI / auxiliary MIPI I3C® full control
1	Primary interface full control

### 6.9.1.1 Auxiliary SPI and auxiliary MIPI I3C® full control

This is the default condition of the device. The auxiliary host (like a camera module) is completely independent from the application processor as shown in Figure 26.

The auxiliary interface can configure OIS functionality through IF2\_INT\_OIS (6Fh), IF2\_CTRL1\_OIS (70h), IF2\_CTRL2\_OIS (71h), IF2\_CTRL3\_OIS (72h).

By default, writing using the auxiliary SPI and writing/reading over the I3C are enabled. The AUX\_SPI\_READ\_EN bit in the IF2\_CTRL1\_OIS (70h) register must be set to 1 to enable reading over the auxiliary SPI. When AUX\_SPI\_READ\_EN is set to 1, the auxiliary I3C target is disabled also.

The primary interface can access the OIS control registers (UI\_INT\_OIS (6Fh), UI\_CTRL1\_OIS (70h), UI\_CTRL2\_OIS (71h), UI\_CTRL3\_OIS (72h)) in read mode.

Figure 26. Auxiliary interface full control

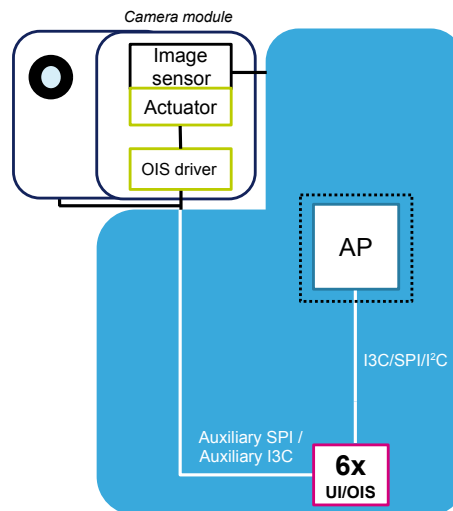

### 6.9.1.2 Primary interface full control

This option allows the application processor to configure all OIS functionalities from the primary interface. This option allows using embedded OIS data for both the main and front camera, connecting them to the application processor (eventually adding a context hub) as shown in Figure 27: the AP can also process the data before sending them to the cameras.

In order to place the device in this mode, the OIS\_CTRL\_FROM\_UI bit in the FUNC\_CFG\_ACCESS (01h) register must be set to 1 from the primary interface.

**Figure 27. OIS primary interface full control**

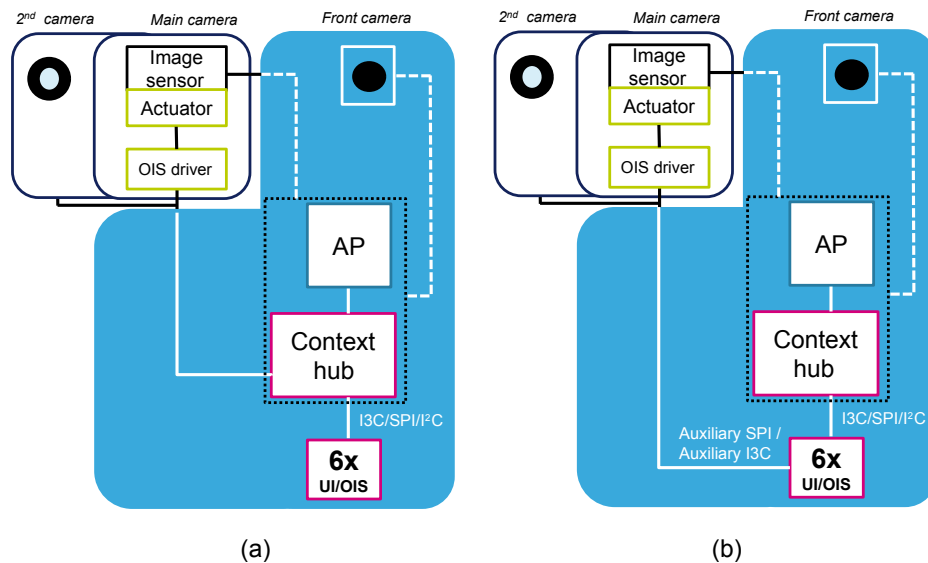

Then, the AP can configure OIS functionalities through UI\_INT\_OIS (6Fh), UI\_CTRL1\_OIS (70h), UI\_CTRL2\_OIS (71h), UI\_CTRL3\_OIS (72h).

By default, writing with the auxiliary SPI and writing/reading over the I3C are enabled. When the auxiliary SPI is used, the AUX\_SPI\_READ\_EN bit in the UI\_CTRL1\_OIS (70h) register shall be set to 1. The AUX\_SPI\_READ\_EN bit enables reading over the SPI interface and it also disables the auxiliary I3C interface (as shown in Figure 27 (b)). The auxiliary SPI can access the IF2\_INT\_OIS (6Fh), IF2\_CTRL1\_OIS (70h), IF2\_CTRL2\_OIS (71h), and IF2\_CTRL3\_OIS (72h) registers in read-only mode.

**Note:** The OIS\_CTRL\_FROM\_UI bit is reset by the software reset procedure.

## 6.10 FIFO

The presence of a FIFO allows consistent power saving for the system since the host processor does not need continuously poll data from the sensor, but it can wake up only when needed and burst the significant data out from the FIFO.

The ISM6HG256X embeds 1.5 KB of data in FIFO (up to 4.5 KB with the compression feature enabled) to store the following data:

- Gyroscope
- Accelerometer
- External sensors (up to 4)
- Step counter
- Timestamp
- Temperature
- MLC features and filters
- SFLP output data (quaternion, gyroscope bias, gravity vector)

Writing data in the FIFO can be configured to be triggered by the:

- Accelerometer / gyroscope data-ready signal
- Sensor hub data-ready signal
- Step detection signal

The applications have maximum flexibility in choosing the rate of batching for physical sensors with FIFO-dedicated configurations: accelerometer, gyroscope and temperature sensor batch rates can be selected by the user. External sensor writing in FIFO can be triggered by the accelerometer data-ready signal or by an external sensor interrupt. The step counter can be stored in FIFO with associated timestamp each time a step is detected. It is possible to select decimation for timestamp batching in FIFO with a factor of 1, 8, or 32.

The reconstruction of a FIFO stream is a simple task thanks to the FIFO\_DATA\_OUT\_TAG byte that allows recognizing the meaning of a word in FIFO.

FIFO allows correct reconstruction of the timestamp information for each sensor stored in FIFO. If a change in the ODR or BDR (batch data rate) configuration is performed, the application can correctly reconstruct the timestamp and know exactly when the change was applied without disabling FIFO batching. FIFO stores information of the new configuration and timestamp in which the change was applied in the device.

Finally, FIFO embeds a compression algorithm that the user can enable in order to have up to 4.5 KB data stored in FIFO and take advantage of interface communication length for FIFO flushing and communication power consumption.

The programmable FIFO watermark threshold can be set using the WTM[7:0] bits in the FIFO\_CTRL1 (07h) register. To monitor the FIFO status, dedicated registers (FIFO\_STATUS1 (1Bh), FIFO\_STATUS2 (1Ch)) can be read to detect FIFO overrun events, FIFO full status, FIFO empty status, FIFO watermark status and the number of unread samples stored in the FIFO. To generate dedicated interrupts on the INT1 and INT2 pins of these status events, the configuration can be set in INT1\_CTRL (0Dh) and INT2\_CTRL (0Eh).

The FIFO buffer can be configured according to seven different modes:

- Bypass mode
- FIFO mode
- Continuous mode
- Continuous-to-FIFO mode
- ContinuousWTM-to-full mode
- Bypass-to-continuous mode
- Bypass-to-FIFO mode

Each mode is selected by the FIFO\_MODE\_[2:0] bits in the FIFO\_CTRL4 (0Ah) register.

### 6.10.1 Bypass mode

In bypass mode (FIFO\_CTRL4 (0Ah)(FIFO\_MODE\_[2:0] = 000), the FIFO is not operational and it remains empty. Bypass mode is also used to reset the FIFO when in FIFO mode.

### 6.10.2 FIFO mode

In FIFO mode (**FIFO\_CTRL4 (0Ah)**(**FIFO\_MODE\_[2:0] = 001**) data from the output channels are stored in the FIFO until it is full.

To reset FIFO content, bypass mode should be selected by writing **FIFO\_CTRL4 (0Ah)**(**FIFO\_MODE\_[2:0]**) to 000. After this reset command, it is possible to restart FIFO mode by writing **FIFO\_CTRL4 (0Ah)** (**FIFO\_MODE\_[2:0]**) to 001.

The FIFO buffer memorizes up to 4.5 KB of data (with compression enabled) but the depth of the FIFO can be resized by setting the **WTM[7:0]** bits in **FIFO\_CTRL1 (07h)**. If the **STOP\_ON\_WTM** bit in **FIFO\_CTRL2 (08h)** is set to 1, FIFO depth is limited up to the **WTM[7:0]** bits in the **FIFO\_CTRL1 (07h)** register.

### 6.10.3 Continuous mode

Continuous mode (**FIFO\_CTRL4 (0Ah)**(**FIFO\_MODE\_[2:0] = 110**) provides a continuous FIFO update: as new data arrives, the older data is discarded.

A FIFO threshold flag **FIFO\_STATUS2 (1Ch)**(**FIFO\_WTM\_IA**) is asserted when the number of unread samples in FIFO is greater than or equal to **FIFO\_CTRL1 (07h)** (**WTM[7:0]**).

It is possible to route the **FIFO\_WTM\_IA** flag to the **INT1** pin by writing in register **INT1\_CTRL (0Dh)** (**INT1\_FIFO\_TH**) = 1 or to the **INT2** pin by writing in register **INT2\_CTRL (0Eh)**(**INT2\_FIFO\_TH**) = 1.

A full-flag interrupt can be enabled, **INT1\_CTRL (0Dh)**(**INT1\_FIFO\_FULL**) = 1 or **INT2\_CTRL (0Eh)** (**INT2\_FIFO\_FULL**) = 1, in order to indicate FIFO saturation and eventually read its content all at once.

If an overrun occurs, at least one of the oldest samples in FIFO has been overwritten and the **FIFO\_OVR\_IA** flag in **FIFO\_STATUS2 (1Ch)** is asserted.

In order to empty the FIFO before it is full, it is also possible to pull from FIFO the number of unread samples available in **FIFO\_STATUS1 (1Bh)** and **FIFO\_STATUS2 (1Ch)**(**DIFF\_FIFO\_[8:0]**).

### 6.10.4 Continuous-to-FIFO mode

In continuous-to-FIFO mode (**FIFO\_CTRL4 (0Ah)**(**FIFO\_MODE\_[2:0] = 011**), FIFO behavior changes according to the trigger event detected in one of the following interrupt events:

- Single tap
- Double tap
- Wake-up
- High-g wake-up
- Free-fall
- D6D

When the selected trigger bit is equal to 1, FIFO operates in FIFO mode.

When the selected trigger bit is equal to 0, FIFO operates in continuous mode.

### 6.10.5 ContinuousWTM-to-full mode

In continuousWTM-to-full mode (**FIFO\_CTRL4 (0Ah)**(**FIFO\_MODE\_[2:0] = 010**), FIFO behavior changes according to the trigger event detected in one of the following interrupt events:

- Single tap
- Double tap
- Wake-up
- High-g wake-up
- Free-fall
- D6D

When the selected trigger bit is equal to 0, FIFO operates in continuous mode with the FIFO size limited to the FIFO watermark level (defined by the **WTM[7:0]** bits in the **FIFO\_CTRL1 (07h)** register).

When the selected trigger bit is equal to 1, FIFO continues to store data until it is full.

### 6.10.6 Bypass-to-continuous mode

In bypass-to-continuous mode (`FIFO_CTRL4 (0Ah)`(`FIFO_MODE_[2:0] = 100`), data measurement storage inside FIFO operates in continuous mode when selected triggers are equal to 1, otherwise FIFO content is reset (bypass mode).

FIFO behavior changes according to the trigger event detected in one of the following interrupt events:

- Single tap
- Double tap
- Wake-up
- High-g wake-up
- Free-fall
- D6D

### 6.10.7 Bypass-to-FIFO mode

In bypass-to-FIFO mode (`FIFO_CTRL4 (0Ah)`(`FIFO_MODE_[2:0] = 111`), data measurement storage inside FIFO operates in FIFO mode when selected triggers are equal to 1, otherwise FIFO content is reset (bypass mode).

FIFO behavior changes according to the trigger event detected in one of the following interrupt events:

- Single tap
- Double tap
- Wake-up
- High-g wake-up
- Free-fall
- D6D

### 6.10.8 FIFO reading procedure

The data stored in FIFO are accessible from dedicated registers and each FIFO word is composed of 7 bytes: one tag byte (`FIFO_DATA_OUT_TAG (78h)`), in order to identify the sensor, and 6 bytes of fixed data (`FIFO_DATA_OUT` registers from `(79h)` to `(7Eh)`).

The `DIFF_FIFO_[8:0]` field in the `FIFO_STATUS1 (1Bh)` and `FIFO_STATUS2 (1Ch)` registers contains the number of words (1 byte TAG + 6 bytes DATA) collected in FIFO.

In addition, it is possible to configure a counter of the batch events of accelerometer or gyroscope sensors. The flag `COUNTER_BDR_IA` in `FIFO_STATUS2 (1Ch)` alerts that the counter reaches a selectable threshold (`CNT_BDR_TH_[9:0]` field in `COUNTER_BDR_REG1 (0Bh)` and `COUNTER_BDR_REG2 (0Ch)`). This allows triggering the reading of FIFO with the desired latency of one single sensor. The sensor is selectable using the `TRIG_COUNTER_BDR_[1:0]` bits in `COUNTER_BDR_REG1 (0Bh)`. As for the other FIFO status events, the flag `COUNTER_BDR_IA` can be routed on the INT1 or INT2 pins by asserting the corresponding bits (`INT1_CNT_BDR` of `INT1_CTRL (0Dh)` and `INT2_CNT_BDR` of `INT2_CTRL (0Eh)`).

In order to maximize the amount of accelerometer and gyroscope data in FIFO, the user can enable the compression algorithm by setting to 1 both the `FIFO_COMPR_EN` bit in `EMB_FUNC_EN_B (05h)` (embedded functions registers bank) and the `FIFO_COMPR_RT_EN` bit in `FIFO_CTRL2 (08h)`. When compression is enabled, it is also possible to force writing noncompressed data at a selectable rate using the `UNCOMPR_RATE_[1:0]` field in `FIFO_CTRL2 (08h)`.

Meta information about accelerometer and gyroscope sensor configuration changes can be managed by enabling the `ODR_CHG_EN` bit in `FIFO_CTRL2 (08h)`.

## 7 Application hints

### 7.1 ISM6HG256X electrical connections in mode 1

Figure 28. ISM6HG256X electrical connections in mode 1

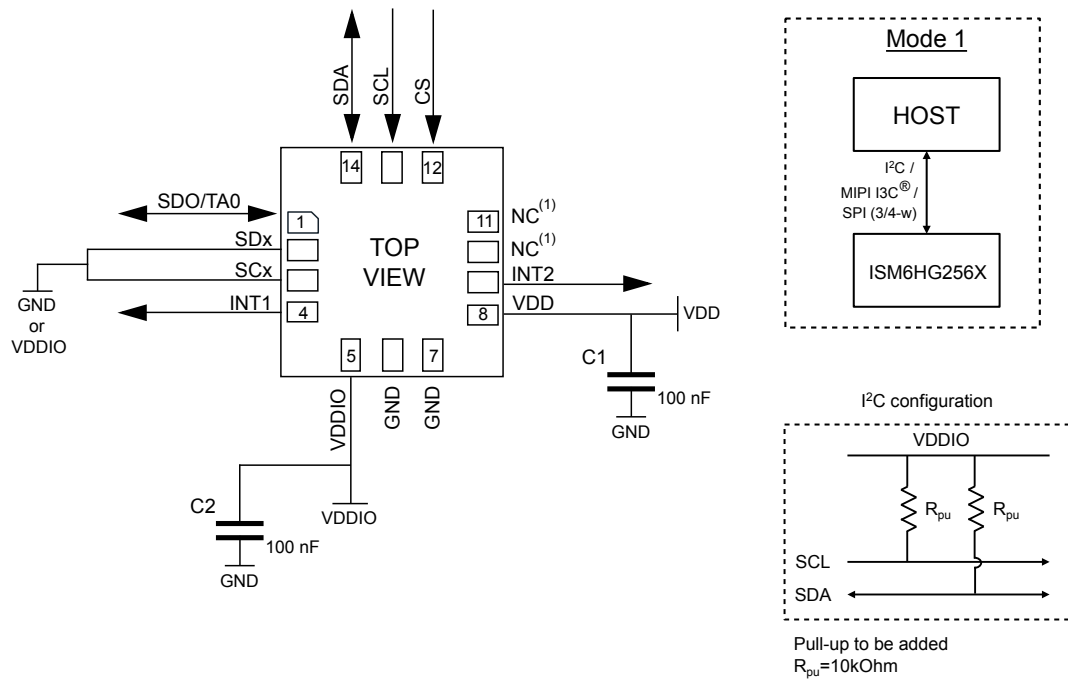

1. Leave pin electrically unconnected and soldered to PCB.

The device core is supplied through the VDD line. Power supply decoupling capacitors (C1, C2 = 100 nF ceramic) should be placed as near as possible to the supply pin of the device (common design practice).

The functionality of the device and the measured acceleration/angular rate data is selectable and accessible through the SPI/I<sup>2</sup>C/MIPI I3C<sup>®</sup> interface.

The functions, the threshold, and the timing of the two interrupt pins for each sensor can be completely programmed by the user through the SPI/I<sup>2</sup>C/MIPI I3C<sup>®</sup> interface.

## 7.2 ISM6HG256X electrical connections in mode 2

Figure 29. ISM6HG256X electrical connections in mode 2

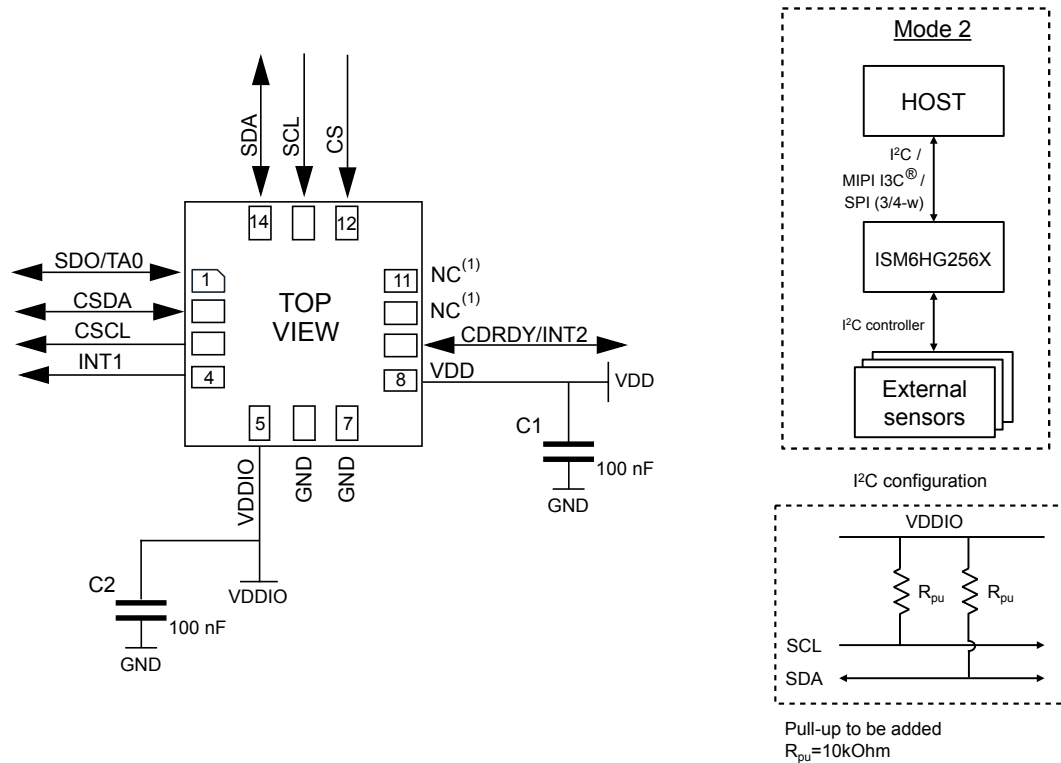

1. Leave pin electrically unconnected and soldered to PCB.

The device core is supplied through the VDD line. Power supply decoupling capacitors (C1, C2 = 100 nF ceramic) should be placed as near as possible to the supply pin of the device (common design practice).

The functionality of the device and the measured acceleration/angular rate data is selectable and accessible through the primary SPI/I<sup>2</sup>C/MIPI I3C<sup>®</sup> interface.

The functions, the threshold, and the timing of the two interrupt pins for each sensor can be completely programmed by the user through the primary SPI/I<sup>2</sup>C/MIPI I3C<sup>®</sup> interface.

### 7.3 ISM6HG256X electrical connections in mode 3

**Figure 30.** ISM6HG256X electrical connections in mode 3 (auxiliary 3/4-wire SPI or auxiliary MIPI I3C)

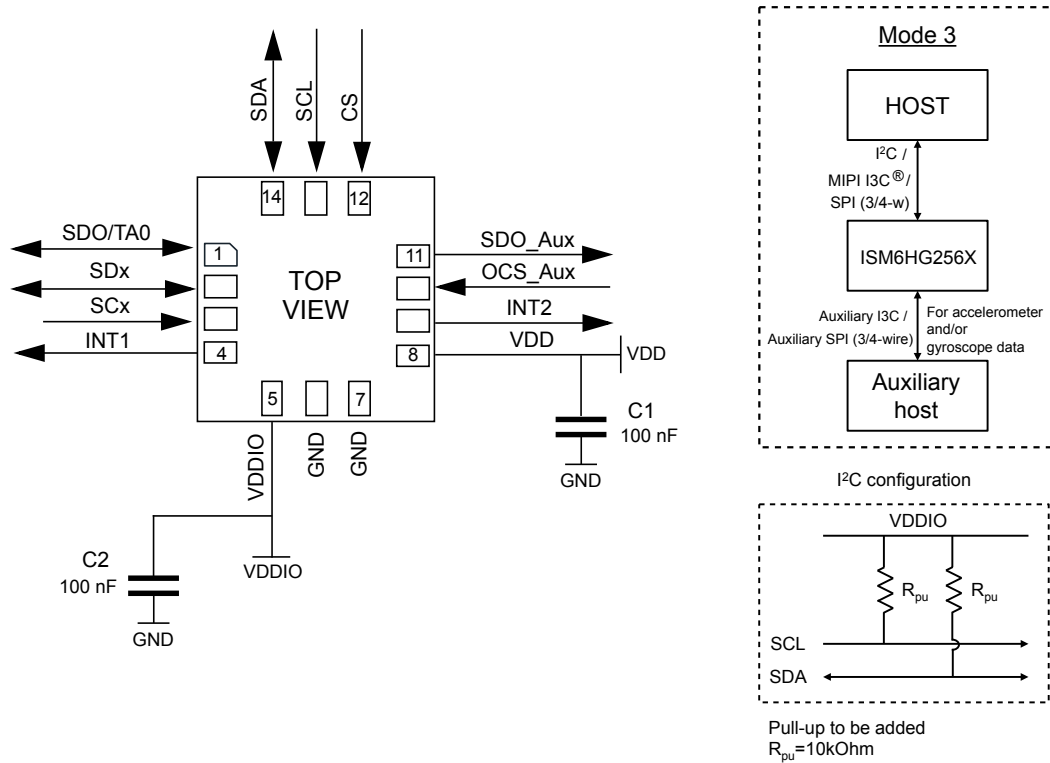

**Note:** When mode 3 is used, the pull-up on pins 10 and 11 can be enabled or disabled (refer to [Table 25. Internal pin status](#)). To avoid leakage current, it is not recommended to leave the SPI lines floating (or when the OIS system is off).

The device core is supplied through the VDD line. Power supply decoupling capacitors (C1, C2 = 100 nF ceramic) should be placed as near as possible to the supply pin of the device (common design practice).

The functionality of the device is selectable and accessible through the SPI/I<sup>2</sup>C/MIPI I3C<sup>®</sup> primary interface.

Measured acceleration/angular rate data is selectable and accessible through the SPI/I<sup>2</sup>C/MIPI I3C<sup>®</sup> primary interface and auxiliary SPI or auxiliary MIPI I3C<sup>®</sup>

The functions, the threshold, and the timing of the two interrupt pins for each sensor can be completely programmed by the user through the SPI/I<sup>2</sup>C/MIPI I3C<sup>®</sup> interface.

**Note:** When mode 3 is used, refer to the product application note for the power mode configuration and settings.

Table 25. Internal pin status

pin#	Name	Mode 1 function	Mode 2 function	Mode 3 function	Pin status mode 1	Pin status mode 2	Pin status mode 3 - I3C	Pin status mode 3 - SPI <sup>(1)</sup>
1	SDO	SPI 4-wire interface serial data output (SDO)	SPI 4-wire interface serial data output (SDO)	SPI 4-wire interface serial data output (SDO)	Default: input without pull-up Pull-up is enabled if bit SDO_PU_EN = 1 in register PIN_CTRL (02h).			
	TA0	I <sup>2</sup> C least significant bit of the device address (TA0) MIPI I3C <sup>®</sup> least significant bit of the static address (TA0)	I <sup>2</sup> C least significant bit of the device address (TA0) MIPI I3C <sup>®</sup> least significant bit of the static address (TA0)	I <sup>2</sup> C least significant bit of the device address (TA0) MIPI I3C <sup>®</sup> least significant bit of the static address (TA0)				
2	SDx	Connect to VDDIO or GND.	I <sup>2</sup> C controller serial data (CSDA)	Auxiliary SPI 3/4-wire interface serial data input (SDI_Aux) and SPI 3-wire serial data output (SDO_Aux) Auxiliary MIPI I3C <sup>®</sup> serial data (SDA_I3C_aux)	Default: input without pull-up Pull-up is enabled if bit SHUB_PU_EN = 1 in register IF_CFG (03h).			
3	SCx	Connect to VDDIO or GND.	I <sup>2</sup> C controller serial clock (CSCL)	Auxiliary SPI 3/4-wire interface serial port clock (SPC_Aux) Auxiliary MIPI I3C <sup>®</sup> serial clock (SCL_I3C_aux)	Default: input without pull-up Pull-up is enabled if bit SHUB_PU_EN = 1 in register IF_CFG (03h).			
4	INT1	Programmable interrupt 1	Programmable interrupt 1	Programmable interrupt 1	Default: output forced to ground			
5	VDDIO	Power supply for I/O pins	Power supply for I/O pins	Power supply for I/O pins				
6	GND	0 V supply	0 V supply	0 V supply				
7	GND	0 V supply	0 V supply	0 V supply				
8	VDD	Power supply	Power supply	Power supply				
9	INT2	Programmable interrupt 2 (INT2) / Data enabled (DEN)	Programmable interrupt 2 (INT2) / Data enabled (DEN) / I <sup>2</sup> C controller external synchronization signal (CDRDY)	Programmable interrupt 2 (INT2) / Data enabled (DEN)	Default: output forced to ground			
10	OCS_Aux	Connect to VDDIO or leave unconnected	Connect to VDDIO or leave unconnected	Auxiliary MIPI I3C <sup>®</sup> / Auxiliary SPI mode selection  (1: Aux. SPI idle mode / Aux. MIPI I3C <sup>®</sup> communication enabled; 0: Aux. SPI communication mode / Aux. MIPI I3C <sup>®</sup> disabled)	Default: input with pull-up Pull-up is disabled if bit OIS_PU_DIS = 1 in register PIN_CTRL (02h).			Default: input without pull-up (regardless of the value of bit OIS_PU_DIS in register PIN_CTRL (02h))
11	SDO_Aux	Connect to VDDIO or leave unconnected	Connect to VDDIO or leave unconnected	Auxiliary SPI 3-wire interface: leave unconnected / Auxiliary SPI 4-wire interface: serial data output (SDO_Aux)	Default: input with pull-up Pull-up is disabled if bit OIS_PU_DIS = 1 in register PIN_CTRL (02h).			Default: input without pull-up Pull-up is enabled if bit SIM_OIS = 1 (Aux_SPI 3-wire) in reg 70h and bit OIS_PU_DIS = 0 in register PIN_CTRL (02h).

pin#	Name	Mode 1 function	Mode 2 function	Mode 3 function	Pin status mode 1	Pin status mode 2	Pin status mode 3 - I3C	Pin status mode 3 - SPI <sup>(1)</sup>
12	CS	I <sup>2</sup> C/SPI mode selection (1: SPI idle mode / I <sup>2</sup> C communication enabled; 0: SPI communication mode / I <sup>2</sup> C disabled)	I <sup>2</sup> C/SPI mode selection (1: SPI idle mode / I <sup>2</sup> C communication enabled; 0: SPI communication mode / I <sup>2</sup> C disabled)	I <sup>2</sup> C/SPI mode selection (1: SPI idle mode / I <sup>2</sup> C or I3C communication enabled; 0: SPI communication mode / I <sup>2</sup> C and I3C disabled)				Default: input with pull-up Pull-up is disabled if bit I2C_I3C_disable = 1 in register IF_CFG (03h).
13	SCL	I <sup>2</sup> C/MIPI I3C <sup>®</sup> serial clock (SCL) / SPI serial port clock (SPC)	I <sup>2</sup> C/MIPI I3C <sup>®</sup> serial clock (SCL) / SPI serial port clock (SPC)	I <sup>2</sup> C/MIPI I3C <sup>®</sup> serial clock (SCL) / SPI serial port clock (SPC)				Default: input without pull-up
14	SDA	I <sup>2</sup> C/MIPI I3C <sup>®</sup> serial data (SDA) / SPI serial data input (SDI) / 3-wire interface serial data output (SDO)	I <sup>2</sup> C/MIPI I3C <sup>®</sup> serial data (SDA) / SPI serial data input (SDI) / 3-wire interface serial data output (SDO)	I <sup>2</sup> C/MIPI I3C <sup>®</sup> serial data (SDA) / SPI serial data input (SDI) / 3-wire interface serial data output (SDO)				Default: input without pull-up Pull-up is enabled if bit SDA_PU_EN = 1 in register IF_CFG (03h).

1. Mode 3 - SPI is enabled when the AUX\_SPI\_READ\_EN bit in the UI\_CTRL1\_OIS (70h) / IF2\_CTRL1\_OIS (70h) registers is set to 1.

The internal pull-up value is from 30 kΩ to 50 kΩ, depending on VDDIO.



## 8 Register mapping

The table given below provides a list of the 8/16-bit registers embedded in the device and the corresponding addresses.

All these registers are accessible from the primary SPI/I<sup>2</sup>C/MIPI I3C<sup>®</sup> interface only.

**Table 26. Registers address map**

Name	Type	Register address		Default	Comment
		Hex	Binary		
FUNC_CFG_ACCESS	R/W	01	00000001	00000000	
PIN_CTRL	R/W	02	00000010	00100011	
IF_CFG	R/W	03	00000011	00000000	
RESERVED	-	04-05			
ODR_TRIG_CFG	R/W	06	00000110	00000000	
FIFO_CTRL1	R/W	07	00000111	00000000	
FIFO_CTRL2	R/W	08	00001000	00000000	
FIFO_CTRL3	R/W	09	00001001	00000000	
FIFO_CTRL4	R/W	0A	00001010	00000000	
COUNTER_BDR_REG1	R/W	0B	00001011	00000000	
COUNTER_BDR_REG2	R/W	0C	00001100	00000000	
INT1_CTRL	R/W	0D	00001101	00000000	
INT2_CTRL	R/W	0E	00001110	00000000	
WHO_AM_I	R	0F	00001111	01110011	R (IF2)
CTRL1	R/W	10	00010000	00000000	R (IF2)
CTRL2	R/W	11	00010001	00000000	R (IF2)
CTRL3	R/W	12	00010010	01000100	R (IF2)
CTRL4	R/W	13	00010011	00000000	R (IF2)
CTRL5	R/W	14	00010100	00000000	R (IF2)
CTRL6	R/W	15	00010101	00001000	R (IF2)
CTRL7	R/W	16	00010110	00000000	R (IF2)
CTRL8	R/W	17	0001 0111	00000000	R (IF2)
CTRL9	R/W	18	00011000	00000000	R (IF2)
CTRL10	R/W	19	00011001	00000000	R (IF2)
CTRL_STATUS	R	1A	00011010	output	
FIFO_STATUS1	R	1B	00011011	output	
FIFO_STATUS2	R	1C	00011100	output	
ALL_INT_SRC	R	1D	00011101	output	
STATUS_REG	R	1E	00011110	output	
RESERVED	-	1F			
OUT_TEMP_L	R	20	00100000	output	
OUT_TEMP_H	R	21	00100001	output	
OUTX_L_G	R	22	00100010	output	
OUTX_H_G	R	23	00100011	output	

Name	Type	Register address		Default	Comment
		Hex	Binary		
OUTY_L_G	R	24	00100100	output	
OUTY_H_G	R	25	00100101	output	
OUTZ_L_G	R	26	00100110	output	
OUTZ_H_G	R	27	00100111	output	
OUTX_L_A	R	28	00101000	output	
OUTX_H_A	R	29	00101001	output	
OUTY_L_A	R	2A	00101010	output	
OUTY_H_A	R	2B	00101011	output	
OUTZ_L_A	R	2C	00101100	output	
OUTZ_H_A	R	2D	00101101	output	
UI_OUTX_L_G_OIS_EIS	R	2E	00101110	output	
UI_OUTX_H_G_OIS_EIS	R	2F	00101111	output	
UI_OUTY_L_G_OIS_EIS	R	30	00110000	output	
UI_OUTY_H_G_OIS_EIS	R	31	00110001	output	
UI_OUTZ_L_G_OIS_EIS	R	32	00110010	output	
UI_OUTZ_H_G_OIS_EIS	R	33	00110011	output	
UI_OUTX_L_A_OIS_HG	R	34	00110100	output	
UI_OUTX_H_A_OIS_HG	R	35	00110101	output	
UI_OUTY_L_A_OIS_HG	R	36	00110110	output	
UI_OUTY_H_A_OIS_HG	R	37	00110111	output	
UI_OUTZ_L_A_OIS_HG	R	38	00111000	output	
UI_OUTZ_H_A_OIS_HG	R	39	00111001	output	
RESERVED	-	3A-3F			
TIMESTAMP0	R	40	01000000	output	R (IF2)
TIMESTAMP1	R	41	01000001	output	R (IF2)
TIMESTAMP2	R	42	01000010	output	R (IF2)
TIMESTAMP3	R	43	01000011	output	R (IF2)
UI_STATUS_REG_OIS	R	44	01000100	output	
WAKE_UP_SRC	R	45	01000101	output	
TAP_SRC	R	46	01000110	output	
D6D_SRC	R	47	01000111	output	
STATUS_CONTROLLER_MAINPAGE	R	48	01001000	output	
EMB_FUNC_STATUS_MAINPAGE	R	49	01001001	output	
FSM_STATUS_MAINPAGE	R	4A	01001010	output	
MLC_STATUS_MAINPAGE	R	4B	01001011	output	
HG_WAKE_UP_SRC	R/W	4C	01001100	00000000	
CTRL2_XL_HG	R/W	4D	01001101	00000000	
CTRL1_XL_HG	R/W	4E	01001110	00000000	
INTERNAL_FREQ_FINE	R	4F	01001111	output	



Name	Type	Register address		Default	Comment
		Hex	Binary		
FUNCTIONS_ENABLE	RW	50	01010000	00000000	
RESERVED	-	51			
HG_FUNCTIONS_ENABLE	R/W	52	01010010	00000000	
HG_WAKE_UP_THS	R/W	53	01010011	00000000	
INACTIVITY_DUR	R/W	54	01010100	00000100	
INACTIVITY_THS	R/W	55	01010101	00000000	
TAP_CFG0	R/W	56	01010110	00000000	
TAP_CFG1	R/W	57	01010111	00000000	
TAP_CFG2	R/W	58	01011000	00000000	
TAP_THS_6D	R/W	59	01011001	00000000	
TAP_DUR	R/W	5A	01011010	00000000	
WAKE_UP_THS	R/W	5B	01011011	00000000	
WAKE_UP_DUR	R/W	5C	01011100	00000000	
FREE_FALL	R/W	5D	01011101	00000000	
MD1_CFG	R/W	5E	01011110	00000000	
MD2_CFG	R/W	5F	01011111	00000000	
RESERVED	-	60-61			
HAODR_CFG	R/W	62	01100010	00000000	
EMB_FUNC_CFG	R/W	63	01100011	00000000	
UI_HANDSHAKE_CTRL	R/W	64	01100100	00000000	
UI_IF2_SHARED_0	R/W	65	01100101	00000000	
UI_IF2_SHARED_1	R/W	66	01100110	00000000	
UI_IF2_SHARED_2	R/W	67	01100111	00000000	
UI_IF2_SHARED_3	R/W	68	01101000	00000000	
UI_IF2_SHARED_4	R/W	69	01101001	00000000	
UI_IF2_SHARED_5	R/W	6A	01101010	00000000	
CTRL_EIS	R/W	6B	01101011	00000000	
XL_HG_X_OFS_USR	R/W	6C	01101100	00000000	
XL_HG_Y_OFS_USR	R/W	6D	01101101	00000000	
XL_HG_Z_OFS_USR	R/W	6E	01101110	00000000	
UI_INT_OIS	R (auxiliary IF full-control mode) R/W (primary IF full-control mode)	6F	01101111	00000000	
UI_CTRL1_OIS	R (auxiliary IF full-control mode) R/W (primary IF full-control mode)	70	01110000	00000000	
UI_CTRL2_OIS	R (auxiliary IF full-control mode) R/W (primary IF full-control mode)	71	01110001	00000000	
UI_CTRL3_OIS	R (auxiliary IF full-control mode) R/W (primary IF full-control mode)	72	01110010	00000000	
X_OFS_USR	R/W	73	01110011	00000000	
Y_OFS_USR	R/W	74	01110100	00000000	
Z_OFS_USR	R/W	75	01110101	00000000	
RESERVED	-	76-77			

Name	Type	Register address		Default	Comment
		Hex	Binary		
FIFO_DATA_OUT_TAG	R	78	01111000	output	
FIFO_DATA_OUT_X_L	R	79	01111001	output	
FIFO_DATA_OUT_X_H	R	7A	01111010	output	
FIFO_DATA_OUT_Y_L	R	7B	01111011	output	
FIFO_DATA_OUT_Y_H	R	7C	01111100	output	
FIFO_DATA_OUT_Z_L	R	7D	01111101	output	
FIFO_DATA_OUT_Z_H	R	7E	01111110	output	

Reserved registers must not be changed. Writing to those registers may cause permanent damage to the device. The content of the registers that are loaded at boot should not be changed. They contain the factory calibration values. Their content is automatically restored when the device is powered up.

## 9 Register description

The device contains a set of registers which are used to control its behavior and to retrieve linear acceleration, angular rate, and temperature data. The register addresses, made up of 7 bits, are used to identify them and to write the data through the serial interface.

### 9.1 FUNC\_CFG\_ACCESS (01h)

Enable embedded functions register (R/W)

**Table 27. FUNC\_CFG\_ACCESS register**

EMB_FUNC_REG_ACCESS	SHUB_REG_ACCESS	0 <sup>(1)</sup>	0 <sup>(1)</sup>	FSM_WR_CTRL_EN	SW_POR	AUX_SPI_RESET	OIS_CTRL_FROM_UI
---------------------	-----------------	------------------	------------------	----------------	--------	---------------	------------------

1. This bit must be set to 0 for the correct operation of the device.

**Table 28. FUNC\_CFG\_ACCESS register description**

EMB_FUNC_REG_ACCESS	Enables access to the embedded functions configuration registers. <sup>(1)</sup> Default value: 0
SHUB_REG_ACCESS	Enables access to the sensor hub (I <sup>2</sup> C controller) configuration registers. <sup>(2)</sup> Default value: 0
FSM_WR_CTRL_EN	Enables the control of the CTRL registers to FSM (FSM can change some configurations of the device autonomously). Default value: 0 (0: disabled; 1: enabled)
SW_POR	Global reset of the device. Default value: 0
AUX_SPI_RESET	Resets the control registers of the auxiliary SPI from the primary interface. This bit must be set to 1 and then back to 0 (this bit is not automatically cleared). Default value: 0
OIS_CTRL_FROM_UI	Enables the full control of OIS configurations from the primary interface. Default value: 0 (0: OIS chain full control from primary interface disabled; 1: OIS chain full control from primary interface enabled)

1. Details concerning the embedded functions configuration registers are available in [Section 12: Embedded functions register mapping](#) and [Section 13: Embedded functions register description](#).
2. Details concerning the sensor hub registers are available in [Section 16: Sensor hub register mapping](#) and [Section 17: Sensor hub register description](#).

## 9.2 PIN\_CTRL (02h)

SDO, OCS\_Aux, SDO\_Aux pins pull-up register (R/W). This register is not reset during the software reset procedure (see bit 0 of the CTRL3 (12h) register).

**Table 29. PIN\_CTRL register**

OIS_PU_DIS	SDO_PU_EN	IBHR_POR_EN	0 <sup>(1)</sup>	0 <sup>(1)</sup>	0 <sup>(1)</sup>	IO_PAD_STRENGTH_1	IO_PAD_STRENGTH_0
------------	-----------	-------------	------------------	------------------	------------------	-------------------	-------------------

1. This bit must be set to 0 for the correct operation of the device.

**Table 30. PIN\_CTRL register description**

OIS_PU_DIS	Disables pull-up on both OCS_Aux and SDO_Aux pins (for mode 1 and mode 2). For further details about the configuration of the pull-up resistors in mode 3, refer to Table 25. Default value: 0 (0: OCS_Aux and SDO_Aux pins with pull-up; 1: OCS_Aux and SDO_Aux pins pull-up disconnected)
SDO_PU_EN	Enables pull-up on SDO pin. For details, refer to Table 25. Default value: 0 (0: SDO pin pull-up disconnected; 1: SDO pin with pull-up)
IBHR_POR_EN	Selects the action that the device performs after "reset whole chip" I3C pattern. Default value: 1 (0: configuration reset (software reset + dynamic address reset); 1: global reset (POR reset))
IO_PAD_STRENGTH[1:0]	Defines the drive strength for the interrupt pads. Default value: 11 (00: lowest strength (recommended for VDDIO ≥ 3.0 V); 01: intermediate strength (recommended for VDDIO ≥ 2.0 V and VDDIO < 3 V); 10: reserved (do not use); 11: highest strength (recommended for VDDIO < 2 V))

### 9.3 IF\_CFG (03h)

Interface configuration register (R/W). This register is not reset during the software reset procedure (see bit 0 of the CTRL3 (12h) register).

**Table 31. IF\_CFG register**

SDA_PU_EN	SHUB_PU_EN	ASF_CTRL	H_LACTIVE	PP_OD	SIM	0 <sup>(1)</sup>	I2C_I3C_disable
-----------	------------	----------	-----------	-------	-----	------------------	-----------------

1. This bit must be set to 0 for the correct operation of the device.

**Table 32. IF\_CFG register description**

SDA_PU_EN	Enables pull-up on SDA pin. Default value: 0 (0: SDA pin pull-up disconnected; 1: SDA pin with pull-up)
SHUB_PU_EN	Enables I <sup>2</sup> C controller pull-up. Default value: 0 (0: internal pull-up on auxiliary I <sup>2</sup> C line disabled; 1: internal pull-up on auxiliary I <sup>2</sup> C line enabled)
ASF_CTRL	Enables antispikes filters. Default value: 0 (0: antispikes filters are managed by the protocol and turned off after the broadcast address; 1: antispikes filters on SCL and SDA lines are always enabled)
H_LACTIVE	Interrupt activation level. Default value: 0 (0: interrupt output pins active high; 1: interrupt output pins active low)
PP_OD	Push-pull/open-drain selection on INT1 and INT2 pins. Default value: 0 (0: push-pull mode; 1: open-drain mode)
SIM	SPI serial interface mode selection. Default value: 0 (0: 4-wire interface; 1: 3-wire interface)
I2C_I3C_disable	Disables I <sup>2</sup> C and MIPI I3C <sup>®</sup> interfaces. Default value: 0 (0: SPI, I <sup>2</sup> C and MIPI I3C <sup>®</sup> interfaces enabled; 1: I <sup>2</sup> C and MIPI I3C <sup>®</sup> interfaces disabled)

### 9.4 ODR\_TRIG\_CFG (06h)

ODR-triggered mode configuration register (R/W)

**Table 33. ODR\_TRIG\_CFG register**

ODR_TRIG_NODR_7	ODR_TRIG_NODR_6	ODR_TRIG_NODR_5	ODR_TRIG_NODR_4	ODR_TRIG_NODR_3	ODR_TRIG_NODR_2	ODR_TRIG_NODR_1	ODR_TRIG_NODR_0
-----------------	-----------------	-----------------	-----------------	-----------------	-----------------	-----------------	-----------------

**Table 34. ODR\_TRIG\_CFG register description**

ODR_TRIG_NODR_[7:0]	When ODR-triggered mode is set, these bits are used to define the number of data generated in the reference period. Allowed values for ODR_TRIG_NODR_[7:0] are 0 (default) and values in the range from 4 to 255.
---------------------	--

## 9.5 FIFO\_CTRL1 (07h)

FIFO control register 1 (R/W)

**Table 35. FIFO\_CTRL1 register**

WTM_7	WTM_6	WTM_5	WTM_4	WTM_3	WTM_2	WTM_1	WTM_0
-------	-------	-------	-------	-------	-------	-------	-------

**Table 36. FIFO\_CTRL1 register description**

WTM_[7:0]	FIFO watermark threshold: 1 LSB = TAG (1 byte) + 1 sensor (6 bytes) written in FIFO. Watermark flag rises when the number of bytes written in the FIFO is greater than or equal to the threshold level.
-----------	--

## 9.6 FIFO\_CTRL2 (08h)

FIFO control register 2 (R/W)

**Table 37. FIFO\_CTRL2 register**

STOP_ON_WTM	FIFO_COMPRT_RT_EN	0 <sup>(1)</sup>	ODR_CHG_EN	0 <sup>(1)</sup>	UNCOMPR_RATE_1	UNCOMPR_RATE_0	0 <sup>(1)</sup>
-------------	-------------------	------------------	------------	------------------	----------------	----------------	------------------

1. This bit must be set to 0 for the correct operation of the device.

**Table 38. FIFO\_CTRL2 register description**

STOP_ON_WTM	Sensing chain FIFO stop values memorization at threshold level. Default value: 0 (0: FIFO depth is not limited; 1: FIFO depth is limited to threshold level, defined in <a href="#">FIFO_CTRL1 (07h)</a> )
FIFO_COMPRT_RT_EN <sup>(1)</sup>	Enables/disables compression algorithm runtime. Default value: 0 (0: FIFO compression algorithm disabled; 1: FIFO compression algorithm enabled)
ODR_CHG_EN	Enables ODR CHANGE virtual sensor to be batched in FIFO. Default value: 0 (0: ODR CHANGE virtual sensor not batched in FIFO; 1: ODR CHANGE virtual sensor batched in FIFO) <i>Note: Refer to the product application note for the details regarding operating/power mode configurations, settings, turn-on/off time and on-the-fly changes.</i>
UNCOMPR_RATE_[1:0]	This field configures the compression algorithm to write uncompressed data at each rate. (0: uncompressed data writing is not forced (default); 1: uncompressed data every 8 batch data rate; 2: uncompressed data every 16 batch data rate; 3: uncompressed data every 32 batch data rate)

1. This bit is activated if the FIFO\_COMPRT\_EN bit of [EMB\\_FUNC\\_EN\\_B \(05h\)](#) is set to 1.

## 9.7 FIFO\_CTRL3 (09h)

FIFO control register 3 (R/W)

**Table 39. FIFO\_CTRL3 register**

BDR_GY_3	BDR_GY_2	BDR_GY_1	BDR_GY_0	BDR_XL_3	BDR_XL_2	BDR_XL_1	BDR_XL_0
----------	----------	----------	----------	----------	----------	----------	----------

**Table 40. FIFO\_CTRL3 register description**

BDR_GY_[3:0]	<p>Selects batch data rate (write frequency in FIFO) for gyroscope data.</p> <p>(0000: gyroscope not batched in FIFO (default);</p> <p>0001: 1.875 Hz;</p> <p>0010: 7.5 Hz;</p> <p>0011: 15 Hz;</p> <p>0100: 30 Hz;</p> <p>0101: 60 Hz;</p> <p>0110: 120 Hz;</p> <p>0111: 240 Hz;</p> <p>1000: 480 Hz;</p> <p>1001: 960 Hz;</p> <p>1010: 1.92 kHz;</p> <p>1011: 3.84 kHz;</p> <p>1100: 7.68 kHz</p> <p>1101-1111: reserved)</p>
BDR_XL_[3:0]	<p>Selects batch data rate (write frequency in FIFO) for accelerometer data.</p> <p>(0000: accelerometer not batched in FIFO (default);</p> <p>0001: 1.875 Hz;</p> <p>0010: 7.5 Hz;</p> <p>0011: 15 Hz;</p> <p>0100: 30 Hz;</p> <p>0101: 60 Hz;</p> <p>0110: 120 Hz;</p> <p>0111: 240 Hz;</p> <p>1000: 480 Hz;</p> <p>1001: 960 Hz;</p> <p>1010: 1.92 kHz;</p> <p>1011: 3.84 kHz;</p> <p>1100: 7.68 kHz</p> <p>1101-1111: reserved)</p>

## 9.8 FIFO\_CTRL4 (0Ah)

FIFO control register 4 (R/W)

**Table 41. FIFO\_CTRL4 register**

DEC_TS_BATCH_1	DEC_TS_BATCH_0	ODR_T_BATCH_1	ODR_T_BATCH_0	G_EIS_FIFO_EN	FIFO_MODE_2	FIFO_MODE_1	FIFO_MODE_0
----------------	----------------	---------------	---------------	---------------	-------------	-------------	-------------

**Table 42. FIFO\_CTRL4 register description**

DEC_TS_BATCH_[1:0]	<p>Selects decimation for timestamp batching in FIFO. Write rate is the maximum rate between the accelerometer and gyroscope BDR divided by decimation decoder.</p> <p>(00: timestamp not batched in FIFO (default);</p> <p>01: decimation 1: <math>\max(\text{BDR\_XL}[\text{Hz}], \text{BDR\_GY}[\text{Hz}])</math> [Hz];</p> <p>10: decimation 8: <math>\max(\text{BDR\_XL}[\text{Hz}], \text{BDR\_GY}[\text{Hz}])/8</math> [Hz];</p> <p>11: decimation 32: <math>\max(\text{BDR\_XL}[\text{Hz}], \text{BDR\_GY}[\text{Hz}])/32</math> [Hz])</p>
ODR_T_BATCH_[1:0]	<p>Selects batch data rate (write frequency in FIFO) for temperature data</p> <p>(00: temperature not batched in FIFO (default);</p> <p>01: 1.875 Hz;</p> <p>10: 15 Hz;</p> <p>11: 60 Hz)</p>
G_EIS_FIFO_EN	<p>Enables FIFO batching of enhanced EIS gyroscope output values. Default value: 0</p> <p>(0: disabled; 1: enabled)</p>
FIFO_MODE_[2:0]	<p>FIFO mode selection</p> <p>(000: bypass mode: FIFO disabled (default);</p> <p>001: FIFO mode: stops collecting data when FIFO is full;</p> <p>010: continuousWTM-to-full mode: continuous mode with FIFO watermark size until trigger is deasserted, then data are stored in FIFO until the buffer is full;</p> <p>011: continuous-to-FIFO mode: continuous mode until trigger is deasserted, then FIFO mode;</p> <p>100: bypass-to-continuous mode: bypass mode until trigger is deasserted, then continuous mode;</p> <p>101: reserved;</p> <p>110: continuous mode: if the FIFO is full, the new sample overwrites the older one;</p> <p>111: bypass-to-FIFO mode: bypass mode until trigger is deasserted, then FIFO mode.)</p>

## 9.9 COUNTER\_BDR\_REG1 (0Bh)

Counter batch data rate register 1 (R/W)

**Table 43. COUNTER\_BDR\_REG1 register**

0 <sup>(1)</sup>	TRIG_COUNTER_BDR_1	TRIG_COUNTER_BDR_0	0 <sup>(1)</sup>	XL_HG_BATCH_EN	0 <sup>(1)</sup>	CNT_BDR_TH_9	CNT_BDR_TH_8
------------------	--------------------	--------------------	------------------	----------------	------------------	--------------	--------------

1. This bit must be set to 0 for the correct operation of the device.

**Table 44. COUNTER\_BDR\_REG1 register description**

TRIG_COUNTER_BDR_[1:0]	Selects the trigger for the internal counter of batch events between the accelerometer, gyroscope and EIS gyroscope. (00: accelerometer batch event; 01: gyroscope batch event; 10 – 11: gyroscope EIS batch event)
XL_HG_BATCH_EN	Enables batching accelerometer high-g data in FIFO. Default value: 0
CNT_BDR_TH_[9:8]	In conjunction with CNT_BDR_TH_[7:0] in <b>COUNTER_BDR_REG2 (0Ch)</b> , sets the threshold for the internal counter of batch events. When this counter reaches the threshold, the counter is reset and the COUNTER_BDR_IA flag in <b>FIFO_STATUS2 (1Ch)</b> is set to 1.

## 9.10 COUNTER\_BDR\_REG2 (0Ch)

Counter batch data rate register 2 (R/W)

**Table 45. COUNTER\_BDR\_REG2 register**

CNT_BDR_TH_7	CNT_BDR_TH_6	CNT_BDR_TH_5	CNT_BDR_TH_4	CNT_BDR_TH_3	CNT_BDR_TH_2	CNT_BDR_TH_1	CNT_BDR_TH_0
--------------	--------------	--------------	--------------	--------------	--------------	--------------	--------------

**Table 46. COUNTER\_BDR\_REG2 register description**

CNT_BDR_TH_[7:0]	In conjunction with CNT_BDR_TH_[9:8] in <b>COUNTER_BDR_REG1 (0Bh)</b> , sets the threshold for the internal counter of batch events. When this counter reaches the threshold, the counter is reset and the COUNTER_BDR_IA flag in <b>FIFO_STATUS2 (1Ch)</b> is set to 1.
------------------	--

## 9.11 INT1\_CTRL (0Dh)

INT1 pin control register (R/W)

Each bit in this register enables a signal to be carried over INT1 when the MIPI I3C<sup>®</sup> dynamic address is not assigned (I<sup>2</sup>C or SPI is used). Some bits can be also used to trigger an IBI (in-band interrupt) when the MIPI I3C<sup>®</sup> interface is used. The output of the pin is the OR combination of the signals selected here and in MD1\_CFG (5Eh).

**Table 47. INT1\_CTRL register**

0 <sup>(1)</sup>	INT1_CNT_BDR	INT1_FIFO_FULL	INT1_FIFO_OVR	INT1_FIFO_TH	0 <sup>(1)</sup>	INT1_DRDY_G	INT1_DRDY_XL
------------------	--------------	----------------	---------------	--------------	------------------	-------------	--------------

1. This bit must be set to 0 for the correct operation of the device.

**Table 48. INT1\_CTRL register description**

INT1_CNT_BDR	Enables COUNTER_BDR_IA interrupt on INT1 pin. Default value: 0
INT1_FIFO_FULL	Enables FIFO full flag interrupt on INT1 pin. It can be also used to trigger an IBI when the MIPI I3C <sup>®</sup> interface is used. Default value: 0
INT1_FIFO_OVR	Enables FIFO overrun interrupt on INT1 pin. It can be also used to trigger an IBI when the MIPI I3C <sup>®</sup> interface is used. Default value: 0
INT1_FIFO_TH	Enables FIFO threshold interrupt on INT1 pin. It can be also used to trigger an IBI when the MIPI I3C <sup>®</sup> interface is used. Default value: 0
INT1_DRDY_G	Enables gyroscope data-ready interrupt on INT1 pin. It can be also used to trigger an IBI when the MIPI I3C <sup>®</sup> interface is used. Default value: 0
INT1_DRDY_XL	Enables accelerometer data-ready interrupt on INT1 pin. It can be also used to trigger an IBI when the MIPI I3C <sup>®</sup> interface is used. Default value: 0

## 9.12 INT2\_CTRL (0Eh)

INT2 pin control register (R/W)

Each bit in this register enables a signal to be carried over INT2 when the MIPI I3C<sup>®</sup> dynamic address is not assigned (I<sup>2</sup>C or SPI is used). Some bits can be also used to trigger an IBI when the MIPI I3C<sup>®</sup> interface is used. The output of the pin is the OR combination of the signals selected here and in MD2\_CFG (5Fh).

**Table 49. INT2\_CTRL register**

INT2_EMB_FUNC_ENDOP	INT2_CNT_BDR	INT2_FIFO_FULL	INT2_FIFO_OVR	INT2_FIFO_TH	INT2_DRDY_G_EIS	INT2_DRDY_G	INT2_DRDY_XL
---------------------	--------------	----------------	---------------	--------------	-----------------	-------------	--------------

**Table 50. INT2\_CTRL register description**

INT2_EMB_FUNC_ENDOP	Enables routing the embedded functions end of operations signal to the INT2 pin. Default value: 0
INT2_CNT_BDR	Enables COUNTER_BDR_IA interrupt on INT2. Default value: 0
INT2_FIFO_FULL	Enables FIFO full flag interrupt on INT2 pin. Default value: 0
INT2_FIFO_OVR	Enables FIFO overrun interrupt on INT2 pin. Default value: 0
INT2_FIFO_TH	Enables FIFO threshold interrupt on INT2 pin. Default value: 0
INT2_DRDY_G_EIS	Enables gyroscope EIS data-ready interrupt on INT2 pin. Default value: 0
INT2_DRDY_G	Gyroscope data-ready interrupt on INT2 pin. Default value: 0
INT2_DRDY_XL	Accelerometer data-ready interrupt on INT2 pin. Default value: 0

## 9.13 WHO\_AM\_I (0Fh)

WHO\_AM\_I register (R). This is a read-only register. Its value is fixed at 73h.

**Table 51. WhoAml register**

0	1	1	1	0	0	1	1
---	---	---	---	---	---	---	---

## 9.14 CTRL1 (10h)

Accelerometer control register 1 (R/W)

**Table 52. CTRL1 register**

0 <sup>(1)</sup>	OP_MODE_XL_2	OP_MODE_XL_1	OP_MODE_XL_0	ODR_XL_3	ODR_XL_2	ODR_XL_1	ODR_XL_0
------------------	--------------	--------------	--------------	----------	----------	----------	----------

1. This bit must be set to 0 for the correct operation of the device.

**Table 53. CTRL1 register description**

OP_MODE_XL_[2:0]	Accelerometer operating mode selection. (000: high-performance mode (default); 001: high-accuracy ODR mode; 010: reserved; 011: ODR-triggered mode; 100: low-power mode 1 (2 mean); 101: low-power mode 2 (4 mean); 110: low-power mode 3 (8 mean); 111: normal mode)
ODR_XL_[3:0]	Accelerometer ODR selection (see Table 54)

**Table 54. Accelerometer ODR selection**

ODR_XL_3	ODR_XL_2	ODR_XL_1	ODR_XL_0	ODR selection [Hz]
0	0	0	0	Power-down (default)
0	0	0	1	1.875 Hz (low-power mode)
0	0	1	0	7.5 Hz (high-performance, normal mode)
0	0	1	1	15 Hz (low-power, high-performance, normal mode)
0	1	0	0	30 Hz (low-power, high-performance, normal mode)
0	1	0	1	60 Hz (low-power, high-performance, normal mode)
0	1	1	0	120 Hz (low-power, high-performance, normal mode)
0	1	1	1	240 Hz (low-power, high-performance, normal mode)
1	0	0	0	480 Hz (high-performance, normal mode)
1	0	0	1	960 Hz (high-performance, normal mode)
1	0	1	0	1.92 kHz (high-performance, normal mode)
1	0	1	1	3.84 kHz (high-performance mode)
1	1	0	0	7.68 kHz (high-performance mode)
Others				Reserved

## 9.15 CTRL2 (11h)

Gyroscope control register 2 (R/W)

**Table 55. CTRL2 register**

0 <sup>(1)</sup>	OP_MODE_G_2	OP_MODE_G_1	OP_MODE_G_0	ODR_G_3	ODR_G_2	ODR_G_1	ODR_G_0
------------------	-------------	-------------	-------------	---------	---------	---------	---------

1. This bit must be set to 0 for the correct operation of the device.

**Table 56. CTRL2 register description**

OP_MODE_G_[2:0]	Gyroscope operating mode selection. (000: high-performance mode (default); 001: high-accuracy ODR mode; 010: reserved; 011: ODR-triggered mode; 100: sleep mode; 101: low-power mode; 110-111: reserved)
ODR_G_[3:0]	Gyroscope output data rate selection. (See Table 57)

**Table 57. Gyroscope ODR selection**

ODR_G_3	ODR_G_2	ODR_G_1	ODR_G_0	ODR [Hz]
0	0	0	0	Power-down (default)
0	0	1	0	7.5 Hz (low-power, high-performance mode)
0	0	1	1	15 Hz (low-power, high-performance mode)
0	1	0	0	30 Hz (low-power, high-performance mode)
0	1	0	1	60 Hz (low-power, high-performance mode)
0	1	1	0	120 Hz (low-power, high-performance mode)
0	1	1	1	240 Hz (low-power, high-performance mode)
1	0	0	0	480 Hz (high-performance mode)
1	0	0	1	960 Hz (high-performance mode)
1	0	1	0	1.92 kHz (high-performance mode)
1	0	1	1	3.84 kHz (high-performance mode)
1	1	0	0	7.68 kHz (high-performance mode)
Others				Reserved

## 9.16 CTRL3 (12h)

Control register 3 (R/W)

**Table 58. CTRL3 register**

BOOT	BDU	0 <sup>(1)</sup>	0 <sup>(1)</sup>	0 <sup>(1)</sup>	IF_INC	0 <sup>(1)</sup>	SW_RESET
------	-----	------------------	------------------	------------------	--------	------------------	----------

1. This bit must be set to 0 for the correct operation of the device.

**Table 59. CTRL3 register description**

BOOT	Reboots memory content. This bit is automatically cleared. Default value: 0 (0: normal mode; 1: reboot memory content)
BDU	Block data update. Default value: 1 (0: continuous update; 1: output registers are not updated until LSB and MSB have been read)
IF_INC	Register address automatically incremented during a multiple byte access with a serial interface (I <sup>2</sup> C, MIPI I3C, or SPI). Default value: 1 (0: disabled; 1: enabled)
SW_RESET	Software reset, resets all control registers to their default value. This bit is automatically cleared. Default value: 0 (0: normal mode; 1: reset device)

## 9.17 CTRL4 (13h)

Control register 4 (R/W)

**Table 60. CTRL4 register**

0 <sup>(1)</sup>	0 <sup>(1)</sup>	0 <sup>(1)</sup>	INT2_on_INT1	DRDY_MASK	INT2_DRDY_TEMP	DRDY_PULSED	INT2_IN_LH
------------------	------------------	------------------	--------------	-----------	----------------	-------------	------------

1. This bit must be set to 0 for the correct operation of the device.

**Table 61. CTRL4 register description**

INT2_on_INT1	<p>Enables routing the embedded functions interrupt signals to the INT1 pin. Default value: 0</p> <ul style="list-style-type: none"> <li>The corresponding bits in the INT2 control registers need to be enabled.</li> <li>These interrupts are in OR with those enabled on the INT1 pin.</li> <li>They are not fed to the INT2 pin.</li> <li>The movable interrupts are:             <ul style="list-style-type: none"> <li>INT2_DRDY_G_EIS and INT2_EMB_FUNC_ENDOP, enabled through INT2_CTRL (0Eh)</li> <li>INT2_TIMESTAMP enabled through MD2_CFG (5Fh)</li> <li>INT2_DRDY_TEMP enabled through CTRL4 (13h)</li> </ul> </li> </ul>
DRDY_MASK	<p>Enables / masks data-ready signal. Default value: 0</p> <p>(0: disabled; 1: masks DRDY signals (both accelerometer and gyroscope) until filter settling ends (accelerometer and gyroscope independently masked))</p> <p><i>Note: Refer to the product application note for the details regarding operating/power mode configurations, settings, turn-on/off time and on-the-fly changes.</i></p>
INT2_DRDY_TEMP	<p>Enables temperature sensor data-ready interrupt on the INT2 pin. It can be also used to trigger an IBI when the MIPI I3C<sup>®</sup> interface is used and INT2_ON_INT1 = 1 in CTRL4_C (13h). Default value: 0</p> <p>(0: disabled; 1: enabled)</p>
DRDY_PULSED	<p>Enables pulsed data-ready mode. Default value: 0</p> <p>(0: data-ready latched mode (returns to 0 only after the higher part of the associated output register has been read); 1: data-ready pulsed mode (the data-ready pulses are 65 μs long))</p>
INT2_IN_LH	<p>Set to 1 in order to change the polarity of the INT2 pin input trigger for DEN or embedded functions. Default value: 0</p> <p>(0: trigger for DEN and embedded functions pin is active low; 1: trigger for DEN and embedded functions pin is active high)</p>

## 9.18 CTRL5 (14h)

Control register 5 (R/W)

**Table 62. CTRL5 register**

AUX_TA0_PID	0 <sup>(1)</sup>	0 <sup>(1)</sup>	0 <sup>(1)</sup>	0 <sup>(1)</sup>	BUS_ACT_SEL_1	BUS_ACT_SEL_0	INT_EN_I3C
-------------	------------------	------------------	------------------	------------------	---------------	---------------	------------

1. This bit must be set to 0 for the correct operation of the device.

**Table 63. CTRL5 register description**

AUX_TA0_PID	Part of the auxiliary device static address (bit[0]). It is also used in PID for the auxiliary interface as explained in MIPI I3C® target auxiliary interface
BUS_ACT_SEL_[1:0]	Bus available time selection for IBI (in-band interrupt): 00: 50 µs (default); 01: 2 µs; 10: 1 ms; 11: 50 ms)
INT_EN_I3C	Enables INT pin when I3C is enabled. Default value: 0 (0: disabled; 1: enabled)

## 9.19 CTRL6 (15h)

Control register 6 (R/W)

**Table 64. CTRL6 register**

0 <sup>(1)</sup>	LPF1_G_BW_2	LPF1_G_BW_1	LPF1_G_BW_0	1 <sup>(2)</sup>	FS_G_2	FS_G_1	FS_G_0
------------------	-------------	-------------	-------------	------------------	--------	--------	--------

1. This bit must be set to 0 for the correct operation of the device.

2. This bit must be set to 1 for the correct operation of the device.

**Table 65. CTRL6 register description**

LPF1_G_BW_[2:0]	Gyroscope low-pass filter (LPF1) bandwidth selection <a href="#">Table 66</a> shows the selectable bandwidth values (available if OIS and/or EIS are disabled).
FS_G_[2:0] <sup>(1)</sup>	Gyroscope UI chain full-scale selection: (000: reserved (default); 001: ±250 dps; 010: ±500 dps; 011: ±1000 dps; 100: ±2000 dps; 101: ±4000 dps)

1. The default configuration of FS\_G\_[2:0] is 000 (reserved). For the correct operation of the device, the user must set a configuration from 001 to 101 when the gyroscope is in power-down mode.

**Table 66. Gyroscope LPF1 + LPF2 bandwidth selection**

LPF1_G_BW_[2:0]	60 Hz	120 Hz	240 Hz	480 Hz	960 Hz	1.92 kHz	3.84 kHz	7.68 kHz
000	24.6	49.4	96	175	241	273	280	281
001	24.6	49.4	96	157	195	210	213	213
010	24.6	49.4	96	131	149	155	156	156
011	24.6	49.4	96	188	310	387	403	407
100	24.6	49.4	78.4	94	100	101	102	102
101	24.6	42.6	53	56.7	57.9	58.2	58.3	58
110	18.0	24.2	27.3	28.4	28.7	28.8	28.8	28.8
111	12.1	13.6	14.2	14.3	14.4	14.4	14.4	14.4

## 9.20 CTRL7 (16h)

Control register 7 (R/W)

**Table 67. CTRL7 register**

INT1_DRDY_XL_HG	INT2_DRDY_XL_HG	0 <sup>(1)</sup>	0 <sup>(1)</sup>	0 <sup>(1)</sup>	0 <sup>(1)</sup>	0 <sup>(1)</sup>	LPF1_G_EN
-----------------	-----------------	------------------	------------------	------------------	------------------	------------------	-----------

1. This bit must be set to 0 for the correct operation of the device.

**Table 68. CTRL7 register description**

INT1_DRDY_XL_HG	Enables a high- <i>g</i> accelerometer data-ready interrupt on the INT1 pin. It can be also used to trigger an IBI when the MIPI I3C® interface is used. Default value: 0
INT2_DRDY_XL_HG	Enables a high- <i>g</i> accelerometer data-ready interrupt on the INT2 pin. Default value: 0
LPF1_G_EN	Enables the gyroscope digital LPF1 filter. If the OIS chain is disabled, the bandwidth can be selected through LPF1_G_BW_[2:0] in CTRL6 (15h)

## 9.21 CTRL8 (17h)

Control register 8 (R/W)

**Table 69. CTRL8 register**

HP_LPF2_XL_BW_2	HP_LPF2_XL_BW_1	HP_LPF2_XL_BW_0	0 <sup>(1)</sup>	0 <sup>(1)</sup>	0 <sup>(1)</sup>	FS_XL_1	FS_XL_0
-----------------	-----------------	-----------------	------------------	------------------	------------------	---------	---------

1. This bit must be set to 0 for the correct operation of the device.

**Table 70. CTRL8 register description**

HP_LPF2_XL_BW_[2:0]	Accelerometer LPF2 and HP filter configuration and cutoff setting. Refer to <a href="#">Table 71</a> .
FS_XL_[1:0]	Accelerometer full-scale selection: (00: ±2 g; 01: ±4 g; 10: ±8 g; 11: ±16 g)

**Table 71. Accelerometer bandwidth configurations**

Filter type	HP_SLOPE_XL_EN	LPF2_XL_EN	HP_LPF2_XL_BW_[2:0]	Bandwidth
Low pass	0	0	-	ODR/2 <sup>(1)</sup>
		1	000	ODR/4
			001	ODR/10
			010	ODR/20
			011	ODR/45
			100	ODR/100
			101	ODR/200
			110	ODR/400
			111	ODR/800
High pass	1	-	000	SLOPE (ODR/4)
			001	ODR/10
			010	ODR/20
			011	ODR/45
			100	ODR/100
			101	ODR/200
			110	ODR/400
			111	ODR/800

1. This value is ODR/2 when the accelerometer is in high-performance mode, high-accuracy ODR mode and normal mode. It is equal to 2300 Hz when the accelerometer is in low-power mode 1 (2 mean), 912 Hz in low-power mode 2 (4 mean) and 431 Hz in low-power mode 3 (8 mean).

## 9.22 CTRL9 (18h)

Control register 9 (R/W)

**Table 72. CTRL9 register**

0 <sup>(1)</sup>	HP_REF_MODE_XL	XL_FASTSETTL_MODE	HP_SLOPE_XL_EN	LPF2_XL_EN	0 <sup>(1)</sup>	USR_OFF_W	USR_OFF_ON_OUT
------------------	----------------	-------------------	----------------	------------	------------------	-----------	----------------

1. This bit must be set to 0 for the correct operation of the device.

**Table 73. CTRL9 register description**

HP_REF_MODE_XL	Enables accelerometer high-pass filter reference mode (valid for high-pass path - HP_SLOPE_XL_EN bit must be 1). Default value: 0 (0: disabled, 1: enabled) <sup>(1)</sup>
XL_FASTSETTL_MODE	Enables accelerometer LPF2 and HPF fast-settling mode. The filter sets the first sample after writing this bit. Active only during device exit from power-down mode. Default value: 0 (0: disabled, 1: enabled)
HP_SLOPE_XL_EN	Accelerometer slope filter / high-pass filter selection. Refer to <a href="#">Figure 31</a> . Default value: 0 (0: low-pass filter path selected; 1: high-pass filter path selected)
LPF2_XL_EN	Accelerometer high-resolution selection. Refer to <a href="#">Figure 31</a> . Default value: 0 (0: output from first stage digital filtering selected; 1: output from LPF2 second filtering stage selected)
USR_OFF_W	Weight of XL user offset bits of registers <a href="#">XL_HG_X_OFS_USR (6Ch)</a> , <a href="#">XL_HG_Y_OFS_USR (6Dh)</a> , <a href="#">XL_HG_Z_OFS_USR (6Eh)</a> . Default value: 0 (0: 2 <sup>-10</sup> g/LSB; 1: 2 <sup>-6</sup> g/LSB)
USR_OFF_ON_OUT	Enables accelerometer user offset correction block; it is valid for the low-pass path. Refer to <a href="#">Figure 31</a> . Default value: 0 (0: accelerometer user offset correction block bypassed; 1: accelerometer user offset correction block enabled)

1. When enabled, the first output data has to be discarded.

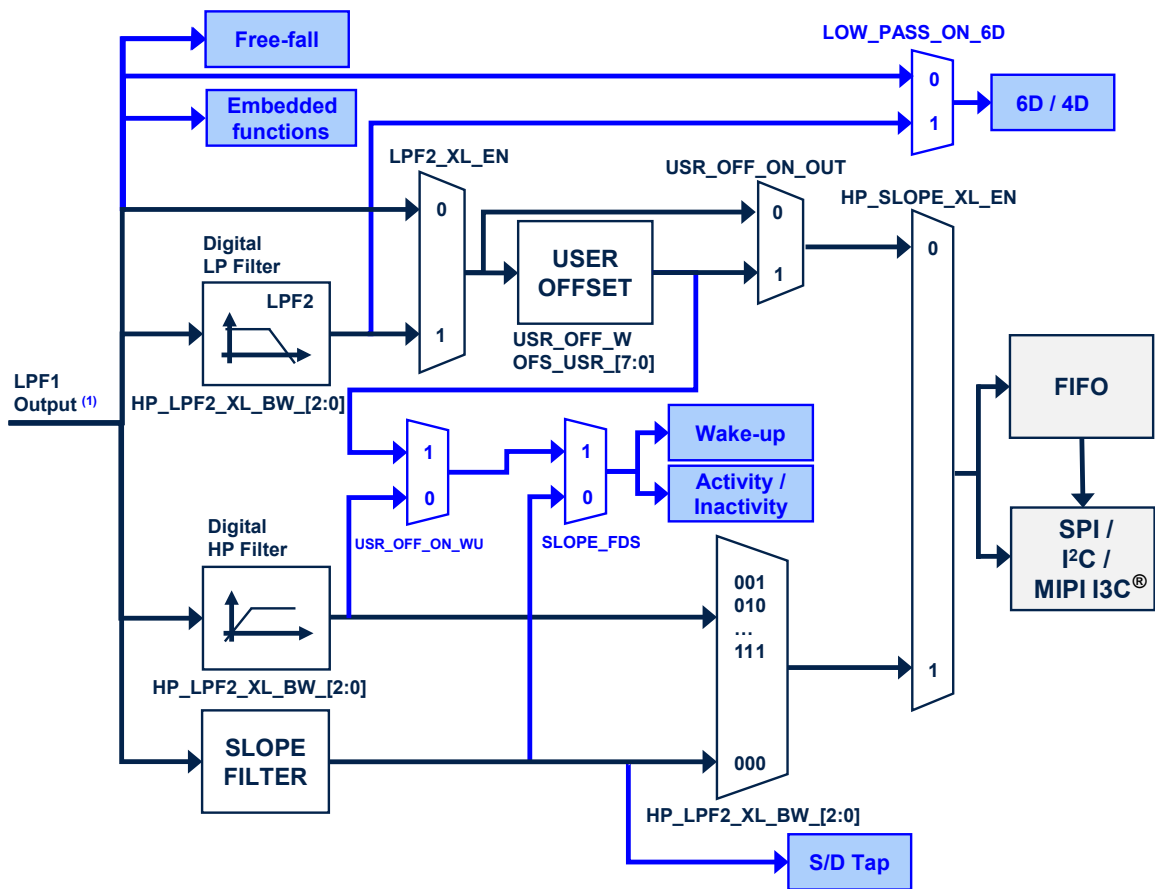
**Figure 31. Accelerometer block diagram**

1. The cutoff value of the LPF1 output is  $ODR/2$  when the accelerometer is in high-performance mode, high-accuracy ODR mode or normal mode. This value is equal to 2300 Hz when the accelerometer is in low-power mode 1 (2 mean), 912 Hz in low-power mode 2 (4 mean) or 431 Hz in low-power mode 3 (8 mean).

## 9.23 CTRL10 (19h)

Control register 10 (R/W)

**Table 74. CTRL10 register**

0 <sup>(1)</sup>	EMB_FUNC_DEBUG	0 <sup>(1)</sup>	0 <sup>(1)</sup>	ST_G_1	ST_G_0	ST_XL_1	ST_XL_0
------------------	----------------	------------------	------------------	--------	--------	---------	---------

1. This bit must be set to 0 for the correct operation of the device.

**Table 75. CTRL10 register description**

EMB_FUNC_DEBUG	Enables debug mode for the embedded functions. (0: disabled; 1: enabled)
ST_G_[1:0]	Gyroscope self-test selection (00: normal mode (default); 01: positive sign self-test; 10: negative sign self-test; 11: reserved)
ST_XL_[1:0]	Accelerometer self-test selection (00: normal mode (default); 01: positive sign self-test; 10: negative sign self-test; 11: reserved)

## 9.24 CTRL\_STATUS (1Ah)

(R)

**Table 76. CTRL\_STATUS register**

0	0	0	0	0	FSM_WR_CTRL_STATUS	-	0
---	---	---	---	---	--------------------	---	---

**Table 77. CTRL\_STATUS register description**

FSM_WR_CTRL_STATUS	This flag indicates the current controller of the device configuration registers. This flag must be used as an acknowledge flag when the value of the FSM_WR_CTRL_EN bit in the <a href="#">FUNC_CFG_ACCESS (01h)</a> register is changed. Default value: 0 (0: all registers and configurations are writable from the standard interface; 1: some registers and configurations are under FSM control and are in read-only mode from the standard interface).
--------------------	---

## 9.25 FIFO\_STATUS1 (1Bh)

FIFO status register 1 (R)

**Table 78. FIFO\_STATUS1 register**

DIFF_FIFO_7	DIFF_FIFO_6	DIFF_FIFO_5	DIFF_FIFO_4	DIFF_FIFO_3	DIFF_FIFO_2	DIFF_FIFO_1	DIFF_FIFO_0
-------------	-------------	-------------	-------------	-------------	-------------	-------------	-------------

**Table 79. FIFO\_STATUS1 register description**

DIFF_FIFO_[7:0]	Number of unread sensor data (TAG + 6 bytes) stored in FIFO In conjunction with DIFF_FIFO_8 in <a href="#">FIFO_STATUS2 (1Ch)</a> .
-----------------	--

## 9.26 FIFO\_STATUS2 (1Ch)

FIFO status register 2 (R)

**Table 80. FIFO\_STATUS2 register**

FIFO_WTM_IA	FIFO_OVR_IA	FIFO_FULL_IA	COUNTER_BDR_IA	FIFO_OVR_LATCHED	0	0	DIFF_FIFO_8
-------------	-------------	--------------	----------------	------------------	---	---	-------------

**Table 81. FIFO\_STATUS2 register description**

FIFO_WTM_IA	FIFO watermark status. Default value: 0 (0: FIFO filling is lower than WTM; 1: FIFO filling is equal to or greater than WTM) Watermark is set through bits WTM[7:0] in <a href="#">FIFO_CTRL2 (08h)</a> and <a href="#">FIFO_CTRL1 (07h)</a> .
FIFO_OVR_IA	FIFO overrun status. Default value: 0 (0: FIFO is not completely filled; 1: FIFO is completely filled)
FIFO_FULL_IA	Smart FIFO full status. Default value: 0 (0: FIFO is not full; 1: FIFO will be full at the next ODR)
COUNTER_BDR_IA	Counter BDR reaches the CNT_BDR_TH_[10:0] threshold set in <a href="#">COUNTER_BDR_REG1 (0Bh)</a> and <a href="#">COUNTER_BDR_REG2 (0Ch)</a> . Default value: 0 This bit is reset when these registers are read.
FIFO_OVR_LATCHED	Latched FIFO overrun status. Default value: 0 This bit is reset when this register is read.
DIFF_FIFO_8	Number of unread sensor data (TAG + 6 bytes) stored in FIFO. Default value: 00 In conjunction with DIFF_FIFO[7:0] in <a href="#">FIFO_STATUS1 (1Bh)</a>

## 9.27 ALL\_INT\_SRC (1Dh)

Source register for all interrupts (R)

**Table 82. ALL\_INT\_SRC register**

EMB_FUNC_IA	SHUB_IA	SLEEP_CHANGE_IA	D6D_IA	HG_IA	TAP_IA	WU_IA	FF_IA
-------------	---------	-----------------	--------	-------	--------	-------	-------

**Table 83. ALL\_INT\_SRC register description**

EMB_FUNC_IA	Embedded functions interrupt status. Default value: 0 (0: embedded functions event not detected; 1: embedded functions event detected)
SHUB_IA	Sensor hub (I <sup>2</sup> C controller) interrupt status. Default value: 0 (0: sensor hub interrupt not generated; 1: sensor hub interrupt generated)
SLEEP_CHANGE_IA	Detects change event in activity/inactivity status. Default value: 0 (0: change status not detected; 1: change status detected)
D6D_IA	Interrupt active for change in position of portrait, landscape, face-up, face-down. Default value: 0 (0: change in position not detected; 1: change in position detected)
HG_IA	High-g interrupt status (logical OR between the high-g wake-up and high-g shock) (0: event on high-g not detected, 1: event on high-g detected)
TAP_IA	Single or double-tap event detection status depending on the SINGLE_DOUBLE_TAP_bit value (see <a href="#">WAKE_UP_THS (5Bh)</a> register). Default value: 0 (0: tap event not detected; 1: tap event detected)
WU_IA	Wake-up event status. Default value: 0 (0: event not detected, 1: event detected)
FF_IA	Free-fall event status. Default value: 0 (0: event not detected, 1: event detected)

## 9.28 STATUS\_REG (1Eh)

The STATUS\_REG register is read by the primary SPI/I<sup>2</sup>C & MIPI I3C<sup>®</sup> interface (R).

**Table 84. STATUS\_REG register**

TIMESTAMP_ENDCOUNT	0	OIS_DRDY	GDA_EIS	XLHGDA	TDA	GDA	XLDA
--------------------	---	----------	---------	--------	-----	-----	------

**Table 85. STATUS\_REG register description**

TIMESTAMP_ENDCOUNT	Alerts timestamp overflow within 5.6 ms
OIS_DRDY	Accelerometer OIS or gyroscope OIS new output data available. Default value: 0 (0: no set of data (accelerometer or gyroscope) available on OIS chain; 1: a new set of data (accelerometer or gyroscope) is available on OIS chain)
GDA_EIS	Enhanced EIS gyroscope new data available. Default value: 0 (0: no set of data available at gyroscope output; 1: a new set of data is available at gyroscope output)
XLHGDA	High-g accelerometer new data available. Default value: 0 (0: no set of data available at accelerometer output; 1: a new set of data is available at accelerometer output)
TDA	Temperature new data available. Default: 0 (0: no set of data is available at temperature sensor output; 1: a new set of data is available at temperature sensor output)
GDA	Gyroscope new data available. Default value: 0 (0: no set of data available at gyroscope output; 1: a new set of data is available at gyroscope output)
XLDA	Accelerometer new data available. Default value: 0 (0: no set of data available at accelerometer output; 1: a new set of data is available at accelerometer output)

## 9.29 OUT\_TEMP\_L (20h), OUT\_TEMP\_H (21h)

Temperature data output register (R). L and H registers together express a 16-bit word in two's complement.

**Table 86. OUT\_TEMP\_L register**

Temp7	Temp6	Temp5	Temp4	Temp3	Temp2	Temp1	Temp0
-------	-------	-------	-------	-------	-------	-------	-------

**Table 87. OUT\_TEMP\_H register**

Temp15	Temp14	Temp13	Temp12	Temp11	Temp10	Temp9	Temp8
--------	--------	--------	--------	--------	--------	-------	-------

**Table 88. OUT\_TEMP register description**

Temp[15:0]	Temperature sensor output data The value is expressed in two's complement.
------------	---

## 9.30 OUTX\_L\_G (22h) and OUTX\_H\_G (23h)

Angular rate sensor pitch axis (X) angular rate output register (R). The value is expressed as a 16-bit word in two's complement.

Data are according to the full-scale (CTRL6 (15h)) and ODR settings (CTRL2 (11h)) of the gyroscope user interface.

**Table 89. OUTX\_L\_G register**

D7	D6	D5	D4	D3	D2	D1	D0
----	----	----	----	----	----	----	----

**Table 90. OUTX\_H\_G register**

D15	D14	D13	D12	D11	D10	D9	D8
-----	-----	-----	-----	-----	-----	----	----

**Table 91. OUTX\_G register description**

D[15:0]	Gyroscope UI chain pitch axis (X) angular rate output value
---------	---

### 9.31 OUTY\_L\_G (24h) and OUTY\_H\_G (25h)

Angular rate sensor roll axis (Y) angular rate output register (R). The value is expressed as a 16-bit word in two's complement.

Data are according to the full-scale (CTRL6 (15h)) and ODR settings (CTRL2 (11h)) of the gyroscope user interface.

**Table 92. OUTY\_L\_G register**

D7	D6	D5	D4	D3	D2	D1	D0
----	----	----	----	----	----	----	----

**Table 93. OUTY\_H\_G register**

D15	D14	D13	D12	D11	D10	D9	D8
-----	-----	-----	-----	-----	-----	----	----

**Table 94. OUTY\_G register description**

D[15:0]	Gyroscope UI chain roll axis (Y) angular rate output value
---------	--

### 9.32 OUTZ\_L\_G (26h) and OUTZ\_H\_G (27h)

Angular rate sensor yaw axis (Z) angular rate output register (R). The value is expressed as a 16-bit word in two's complement.

Data are according to the full-scale (CTRL6 (15h)) and ODR settings (CTRL2 (11h)) of the gyroscope user interface.

**Table 95. OUTZ\_L\_G register**

D7	D6	D5	D4	D3	D2	D1	D0
----	----	----	----	----	----	----	----

**Table 96. OUTZ\_H\_G register**

D15	D14	D13	D12	D11	D10	D9	D8
-----	-----	-----	-----	-----	-----	----	----

**Table 97. OUTZ\_H\_G register description**

D[15:0]	Gyroscope UI chain yaw axis (Z) angular rate output value
---------	---

### 9.33 OUTX\_L\_A (28h) and OUTX\_H\_A (29h)

Linear acceleration sensor X-axis output register (R). The value is expressed as a 16-bit word in two's complement.

Data are according to the full-scale (CTRL8 (17h)) and ODR settings (CTRL1 (10h)) of the accelerometer user interface.

**Table 98. OUTX\_L\_A register**

D7	D6	D5	D4	D3	D2	D1	D0
----	----	----	----	----	----	----	----

**Table 99. OUTX\_H\_A register**

D15	D14	D13	D12	D11	D10	D9	D8
-----	-----	-----	-----	-----	-----	----	----

**Table 100. OUTX\_A register description**

D[15:0]	Accelerometer UI chain X-axis linear acceleration output value
---------	--

### 9.34 OUTY\_L\_A (2Ah) and OUTY\_H\_A (2Bh)

Linear acceleration sensor Y-axis output register (R). The value is expressed as a 16-bit word in two's complement.

Data are according to the full-scale (CTRL8 (17h)) and ODR settings (CTRL1 (10h)) of the accelerometer user interface.

**Table 101. OUTY\_L\_A register**

D7	D6	D5	D4	D3	D2	D1	D0
----	----	----	----	----	----	----	----

**Table 102. OUTY\_H\_A register**

D15	D14	D13	D12	D11	D10	D9	D8
-----	-----	-----	-----	-----	-----	----	----

**Table 103. OUTY\_A register description**

D[15:0]	Accelerometer UI chain Y-axis linear acceleration output value
---------	--

### 9.35 OUTZ\_L\_A (2Ch) and OUTZ\_H\_A (2Dh)

Linear acceleration sensor Z-axis output register (R). The value is expressed as a 16-bit word in two's complement.

Data are according to the full-scale (CTRL8 (17h)) and ODR settings (CTRL1 (10h)) of the accelerometer user interface.

**Table 104. OUTZ\_L\_A register**

D7	D6	D5	D4	D3	D2	D1	D0
----	----	----	----	----	----	----	----

**Table 105. OUTZ\_H\_A register**

D15	D14	D13	D12	D11	D10	D9	D8
-----	-----	-----	-----	-----	-----	----	----

**Table 106. OUTZ\_A register description**

D[15:0]	Accelerometer UI chain Z-axis linear acceleration output value
---------	--

### 9.36 UI\_OUTX\_L\_G\_OIS\_EIS (2Eh) and UI\_OUTX\_H\_G\_OIS\_EIS (2Fh)

Angular rate sensor pitch axis (X) angular rate output register (R). The value is expressed as a 16-bit word in two's complement.

Data are according to the gyroscope full-scale and ODR settings of the OIS gyroscope or the EIS gyroscope channel.

**Table 107. UI\_OUTX\_L\_G\_OIS\_EIS register**

D7	D6	D5	D4	D3	D2	D1	D0
----	----	----	----	----	----	----	----

**Table 108. UI\_OUTX\_H\_G\_OIS\_EIS register**

D15	D14	D13	D12	D11	D10	D9	D8
-----	-----	-----	-----	-----	-----	----	----

**Table 109. UI\_OUTX\_G\_OIS\_EIS register description**

D[15:0]	Gyroscope pitch axis OIS/EIS output expressed in two's complement
---------	---

### 9.37 UI\_OUTY\_L\_G\_OIS\_EIS (30h) and UI\_OUTY\_H\_G\_OIS\_EIS (31h)

Angular rate sensor roll axis (Y) angular rate output register (R). The value is expressed as a 16-bit word in two's complement.

Data are according to the gyroscope full-scale and ODR settings of the OIS gyroscope or the EIS gyroscope channel.

**Table 110. UI\_OUTY\_L\_G\_OIS\_EIS register**

D7	D6	D5	D4	D3	D2	D1	D0
----	----	----	----	----	----	----	----

**Table 111. UI\_OUTY\_H\_G\_OIS\_EIS register**

D15	D14	D13	D12	D11	D10	D9	D8
-----	-----	-----	-----	-----	-----	----	----

**Table 112. UI\_OUTY\_G\_OIS\_EIS register description**

D[15:0]	Gyroscope roll axis OIS/EIS output expressed in two's complement
---------	--

### 9.38 UI\_OUTZ\_L\_G\_OIS\_EIS (32h) and UI\_OUTZ\_H\_G\_OIS\_EIS (33h)

Angular rate sensor yaw axis (Z) angular rate output register (R). The value is expressed as a 16-bit word in two's complement.

Data are according to the gyroscope full-scale and ODR settings of the OIS gyroscope or the EIS gyroscope channel.

**Table 113. UI\_OUTZ\_L\_G\_OIS\_EIS register**

D7	D6	D5	D4	D3	D2	D1	D0
----	----	----	----	----	----	----	----

**Table 114. UI\_OUTZ\_H\_G\_OIS\_EIS register**

D15	D14	D13	D12	D11	D10	D9	D8
-----	-----	-----	-----	-----	-----	----	----

**Table 115. UI\_OUTZ\_G\_OIS\_EIS register description**

D[15:0]	Gyroscope yaw axis OIS/EIS output expressed in two's complement
---------	---

### 9.39 UI\_OUTX\_L\_A\_OIS\_HG (34h) and UI\_OUTX\_H\_A\_OIS\_HG (35h)

Linear acceleration sensor X-axis output register (R). The value is expressed as a 16-bit word in two's complement.

Data are according to the accelerometer full-scale and ODR settings of the OIS accelerometer or according to the accelerometer high-g mode configuration.

**Table 116. UI\_OUTX\_L\_A\_OIS\_HG register**

D7	D6	D5	D4	D3	D2	D1	D0
----	----	----	----	----	----	----	----

**Table 117. UI\_OUTX\_H\_A\_OIS\_HG register**

D15	D14	D13	D12	D11	D10	D9	D8
-----	-----	-----	-----	-----	-----	----	----

**Table 118. UI\_OUTX\_A\_OIS\_HG register description**

D[15:0]	Accelerometer X-axis OIS/high-g output expressed in two's complement
---------	--

### 9.40 UI\_OUTY\_L\_A\_OIS\_HG (36h) and UI\_OUTY\_H\_A\_OIS\_HG (37h)

Linear acceleration sensor Y-axis output register (R). The value is expressed as a 16-bit word in two's complement.

Data are according to the accelerometer full-scale and ODR settings of the OIS accelerometer or according to the accelerometer high-g mode configuration.

**Table 119. UI\_OUTY\_L\_A\_OIS\_HG register**

D7	D6	D5	D4	D3	D2	D1	D0
----	----	----	----	----	----	----	----

**Table 120. UI\_OUTY\_H\_A\_OIS\_HG register**

D15	D14	D13	D12	D11	D10	D9	D8
-----	-----	-----	-----	-----	-----	----	----

**Table 121. UI\_OUTY\_A\_OIS\_HG register description**

D[15:0]	Accelerometer Y-axis OIS/high-g output expressed in two's complement
---------	--

### 9.41 UI\_OUTZ\_L\_A\_OIS\_HG (38h) and UI\_OUTZ\_H\_A\_OIS\_HG (39h)

Linear acceleration sensor Z-axis output register (R). The value is expressed as a 16-bit word in two's complement.

Data are according to the accelerometer full-scale and ODR settings of the OIS accelerometer or according to the accelerometer high-g mode configuration.

**Table 122. UI\_OUTZ\_L\_A\_OIS\_HG register**

D7	D6	D5	D4	D3	D2	D1	D0
----	----	----	----	----	----	----	----

**Table 123. UI\_OUTZ\_H\_A\_OIS\_HG register**

D15	D14	D13	D12	D11	D10	D9	D8
-----	-----	-----	-----	-----	-----	----	----

**Table 124. UI\_OUTZ\_A\_OIS\_HG register description**

D[15:0]	Accelerometer Z-axis OIS/high-g output expressed in two's complement
---------	--

## 9.42 **TIMESTAMP0 (40h), TIMESTAMP1 (41h), TIMESTAMP2 (42h), and TIMESTAMP3 (43h)**

Timestamp first data output register (R). The value is expressed as a 32-bit word and the bit resolution is 21.7  $\mu$ s (typical).

**Table 125. TIMESTAMP output registers**

D31	D30	D29	D28	D27	D26	D25	D24
D23	D22	D21	D20	D19	D18	D17	D16
D15	D14	D13	D12	D11	D10	D9	D8
D7	D6	D5	D4	D3	D2	D1	D0

**Table 126. TIMESTAMP output register description**

D[31:0]	Timestamp output registers: 1LSB = 21.7 $\mu$ s (typical)
---------	---

## 9.43 **UI\_STATUS\_REG\_OIS (44h)**

**Table 127. UI\_STATUS\_REG\_OIS register**

0	0	0	0	0	GYRO_SETTLING	GDA_OIS	XLDA_OIS
---	---	---	---	---	---------------	---------	----------

**Table 128. UI\_STATUS\_REG\_OIS register description**

GYRO_SETTLING	High when the gyroscope output is in the settling phase
GDA_OIS	Gyroscope OIS data available (reset when one of the high parts of the output data is read). Default value: 0 (0: no set of data available at gyroscope OIS output; 1: a new set of data is available at gyroscope output)
XLDA_OIS	Accelerometer OIS data available (reset when one of the high parts of the output data is read). Default value: 0 (0: no set of data available at gyroscope OIS output; 1: a new set of data is available at gyroscope output)

## 9.44 WAKE\_UP\_SRC (45h)

Wake-up interrupt source register (R)

**Table 129. WAKE\_UP\_SRC register**

0	SLEEP_CHANGE_IA	FF_IA	SLEEP_STATE	WU_IA	X_WU	Y_WU	Z_WU
---	-----------------	-------	-------------	-------	------	------	------

**Table 130. WAKE\_UP\_SRC register description**

SLEEP_CHANGE_IA	Detects change event in activity/inactivity status. Default value: 0 (0: change status not detected; 1: change status detected)
FF_IA	Free-fall event detection status. Default: 0 (0: free-fall event not detected; 1: free-fall event detected)
SLEEP_STATE	Sleep status bit. Default value: 0 (0: Activity status; 1: Inactivity status)
WU_IA	Wake-up event detection status. Default value: 0 (0: wake-up event not detected; 1: wake-up event detected.)
X_WU	Wake-up event detection status on X-axis. Default value: 0 (0: wake-up event on X-axis not detected; 1: wake-up event on X-axis detected)
Y_WU	Wake-up event detection status on Y-axis. Default value: 0 (0: wake-up event on Y-axis not detected; 1: wake-up event on Y-axis detected)
Z_WU	Wake-up event detection status on Z-axis. Default value: 0 (0: wake-up event on Z-axis not detected; 1: wake-up event on Z-axis detected)

## 9.45 TAP\_SRC (46h)

Tap source register (R)

**Table 131. TAP\_SRC register**

0	TAP_IA	SINGLE_TAP	DOUBLE_TAP	TAP_SIGN	X_TAP	Y_TAP	Z_TAP
---	--------	------------	------------	----------	-------	-------	-------

**Table 132. TAP\_SRC register description**

TAP_IA	Tap event detection status. Default: 0 (0: tap event not detected; 1: tap event detected)
SINGLE_TAP	Single-tap event status. Default value: 0 (0: single tap event not detected; 1: single tap event detected)
DOUBLE_TAP	Double-tap event detection status. Default value: 0 (0: double-tap event not detected; 1: double-tap event detected.)
TAP_SIGN	Sign of acceleration detected by tap event. Default: 0 (0: positive sign of acceleration detected by tap event; 1: negative sign of acceleration detected by tap event)
X_TAP	Tap event detection status on X-axis. Default value: 0 (0: tap event on X-axis not detected; 1: tap event on X-axis detected)
Y_TAP	Tap event detection status on Y-axis. Default value: 0 (0: tap event on Y-axis not detected; 1: tap event on Y-axis detected)
Z_TAP	Tap event detection status on Z-axis. Default value: 0 (0: tap event on Z-axis not detected; 1: tap event on Z-axis detected)

## 9.46 D6D\_SRC (47h)

Portrait, landscape, face-up and face-down source register (R)

**Table 133. D6D\_SRC register**

0	D6D_IA	ZH	ZL	YH	YL	XH	XL
---	--------	----	----	----	----	----	----

**Table 134. D6D\_SRC register description**

D6D_IA	Interrupt active for change position portrait, landscape, face-up, face-down. Default value: 0 (0: change position not detected; 1: change position detected)
ZH	Z-axis high event (over threshold). Default value: 0 (0: event not detected; 1: event (over threshold) detected)
ZL	Z-axis low event (under threshold). Default value: 0 (0: event not detected; 1: event (under threshold) detected)
YH	Y-axis high event (over threshold). Default value: 0 (0: event not detected; 1: event (over-threshold) detected)
YL	Y-axis low event (under threshold). Default value: 0 (0: event not detected; 1: event (under threshold) detected)
XH	X-axis high event (over threshold). Default value: 0 (0: event not detected; 1: event (over threshold) detected)
XL	X-axis low event (under threshold). Default value: 0 (0: event not detected; 1: event (under threshold) detected)

## 9.47 STATUS\_CONTROLLER\_MAINPAGE (48h)

Sensor hub source register (R)

**Table 135. STATUS\_CONTROLLER\_MAINPAGE register**

WR_ONCE_DONE	TARGET3_NACK	TARGET2_NACK	TARGET1_NACK	TARGET0_NACK	0	0	SENS_HUB_ENDOP
--------------	--------------	--------------	--------------	--------------	---	---	----------------

**Table 136. STATUS\_CONTROLLER\_MAINPAGE register description**

WR_ONCE_DONE	When the bit WRITE_ONCE in <a href="#">CONTROLLER_CONFIG (14h)</a> is configured as 1, this bit is set to 1 when the write operation on target 0 has been performed and completed. Default value: 0
TARGET3_NACK	This bit is set to 1 if not acknowledge occurs on target 3 communication. Default value: 0
TARGET2_NACK	This bit is set to 1 if not acknowledge occurs on target 2 communication. Default value: 0
TARGET1_NACK	This bit is set to 1 if not acknowledge occurs on target 1 communication. Default value: 0
TARGET0_NACK	This bit is set to 1 if not acknowledge occurs on target 0 communication. Default value: 0
SENS_HUB_ENDOP	Sensor hub communication status. Default value: 0 (0: sensor hub communication not concluded; 1: sensor hub communication concluded)

## 9.48 EMB\_FUNC\_STATUS\_MAINPAGE (49h)

Embedded function status register (R)

**Table 137. EMB\_FUNC\_STATUS\_MAINPAGE register**

IS_FSM_LC	0	IS_SIGMOT	IS_TILT	IS_STEP_DET	0	0	0
-----------	---	-----------	---------	-------------	---	---	---

**Table 138. EMB\_FUNC\_STATUS\_MAINPAGE register description**

IS_FSM_LC	Interrupt status bit for FSM long counter timeout interrupt event. (1: interrupt detected; 0: no interrupt)
IS_SIGMOT	Interrupt status bit for significant motion detection (1: interrupt detected; 0: no interrupt)
IS_TILT	Interrupt status bit for tilt detection (1: interrupt detected; 0: no interrupt)
IS_STEP_DET	Interrupt status bit for step detection (1: interrupt detected; 0: no interrupt)

## 9.49 FSM\_STATUS\_MAINPAGE (4Ah)

Finite state machine status register (R)

**Table 139. FSM\_STATUS\_MAINPAGE register**

IS_FSM8	IS_FSM7	IS_FSM6	IS_FSM5	IS_FSM4	IS_FSM3	IS_FSM2	IS_FSM1
---------	---------	---------	---------	---------	---------	---------	---------

**Table 140. FSM\_STATUS\_MAINPAGE register description**

IS_FSM8	Interrupt status bit for FSM8 interrupt event. (1: interrupt detected; 0: no interrupt)
IS_FSM7	Interrupt status bit for FSM7 interrupt event. (1: interrupt detected; 0: no interrupt)
IS_FSM6	Interrupt status bit for FSM6 interrupt event. (1: interrupt detected; 0: no interrupt)
IS_FSM5	Interrupt status bit for FSM5 interrupt event. (1: interrupt detected; 0: no interrupt)
IS_FSM4	Interrupt status bit for FSM4 interrupt event. (1: interrupt detected; 0: no interrupt)
IS_FSM3	Interrupt status bit for FSM3 interrupt event. (1: interrupt detected; 0: no interrupt)
IS_FSM2	Interrupt status bit for FSM2 interrupt event. (1: interrupt detected; 0: no interrupt)
IS_FSM1	Interrupt status bit for FSM1 interrupt event. (1: interrupt detected; 0: no interrupt)

## 9.50 MLC\_STATUS\_MAINPAGE (4Bh)

Machine learning core status register (R)

**Table 141. MLC\_STATUS\_MAINPAGE register**

IS_MLC8	IS_MLC7	IS_MLC6	IS_MLC5	IS_MLC4	IS_MLC3	IS_MLC2	IS_MLC1
---------	---------	---------	---------	---------	---------	---------	---------

**Table 142. MLC\_STATUS\_MAINPAGE register description**

IS_MLC8	Interrupt status bit for MLC8 interrupt event. (1: interrupt detected; 0: no interrupt)
IS_MLC7	Interrupt status bit for MLC7 interrupt event. (1: interrupt detected; 0: no interrupt)
IS_MLC6	Interrupt status bit for MLC6 interrupt event. (1: interrupt detected; 0: no interrupt)
IS_MLC5	Interrupt status bit for MLC5 interrupt event. (1: interrupt detected; 0: no interrupt)
IS_MLC4	Interrupt status bit for MLC4 interrupt event. (1: interrupt detected; 0: no interrupt)
IS_MLC3	Interrupt status bit for MLC3 interrupt event. (1: interrupt detected; 0: no interrupt)
IS_MLC2	Interrupt status bit for MLC2 interrupt event. (1: interrupt detected; 0: no interrupt)
IS_MLC1	Interrupt status bit for MLC1 interrupt event. (1: interrupt detected; 0: no interrupt)

## 9.51 HG\_WAKE\_UP\_SRC (4Ch)

High-g wake-up source register (R)

**Table 143. HG\_WAKE\_UP\_SRC register**

-	HG_SHOCK_CHANGE_IA	HG_SHOCK_STATE	HG_WU_CHANGE_IA	HG_WU_IA	HG_X_WU	HG_Y_WU	HG_Z_WU
---	--------------------	----------------	-----------------	----------	---------	---------	---------

**Table 144. HG\_WAKE\_UP\_SRC register description**

HG_SHOCK_CHANGE_IA	High-g shock state change event detected. Default value: 0 (0: shock state change event not detected; 1: shock state change event detected)
HG_SHOCK_STATE	High-g shock function is in shock state. Default value: 0 (0: high-g shock function not in shock state; 1: high-g shock function in shock state)
HG_WU_CHANGE_IA	High-g wake-up change event detection status (high-g data passes from all axes under the threshold to at least one axis over the threshold, or vice versa). Default value: 0 (0: wake-up change event not detected; 1: wake-up change event detected)
HG_WU_IA	High-g wake-up event detection status (one axis exceeds threshold). Default value: 0 (0: wake-up event not detected; 1: wake-up event detected)
HG_X_WU	High-g wake-up event detection status on the X-axis. Default value: 0 (0: wake-up event on the X-axis not detected; 1: wake-up event on the X-axis detected)
HG_Y_WU	High-g wake-up event detection status on the Y-axis. Default value: 0 (0: wake-up event on the Y-axis not detected; 1: wake-up event on the Y-axis detected)
HG_Z_WU	High-g wake-up event detection status on the Z-axis. Default value: 0 (0: wake-up event on the Z-axis not detected; 1: wake-up event on the Z-axis detected)

## 9.52 CTRL2\_XL\_HG (4Dh)

Control register 2 high-g accelerometer (R/W)

**Table 145. CTRL2\_XL\_HG register**

0 <sup>(1)</sup>	0 <sup>(1)</sup>	0 <sup>(1)</sup>	HG_USR_ OFF_ON_WU	0 <sup>(1)</sup>	0 <sup>(1)</sup>	XL_HG_ST1	XL_HG_ST0
------------------	------------------	------------------	----------------------	------------------	------------------	-----------	-----------

1. This bit must be set to 0 for the correct operation of the device.

**Table 146. CTRL2\_XL\_HG register description**

HG_USR_OFF_ON_WU	Drives the data with user offset correction to the high-g wake-up and high-g shock
XL_HG_ST[1:0]	High-g accelerometer self-test selection (00: normal mode (default); 01: positive sign self-test; 10: negative sign self-test; 11: reserved)

## 9.53 CTRL1\_XL\_HG (4Eh)

Control register 1 high-g accelerometer (R/W)

**Table 147. CTRL1\_XL\_HG register**

XL_HG_ REGOUT_EN	HG_USR_ OFF_ON_OUT	ODR_XL_ HG_2	ODR_XL_ HG_1	ODR_XL_ HG_0	FS_XL_ HG_2	FS_XL_ HG_1	FS_XL_ HG_0
---------------------	-----------------------	-----------------	-----------------	-----------------	----------------	----------------	----------------

**Table 148. CTRL1\_XL\_HG register description**

XL_HG_REGOUT_EN	Enables read of high-g accelerometer channel from output registers UI_OUTX_L_A_OIS_HG (34h) and UI_OUTX_H_A_OIS_HG (35h) through UI_OUTZ_L_A_OIS_HG (38h) and UI_OUTZ_H_A_OIS_HG (39h)
HG_USR_OFF_ON_OUT	Enables high-g accelerometer user offset functionality on output registers
ODR_XL_HG [2:0]	High-g accelerometer ODR selection, see Table 149
FS_XL_HG [2:0]	High-g accelerometer full-scale selection, see Table 150

**Table 149. High-g accelerometer ODR selection**

Code	ODR	Code	ODR
000	Power-down (default)	100	960 Hz
001	N/A	101	1.92 kHz
010	N/A	110	3.84 kHz
011	480 Hz	111	7.68 kHz

**Table 150. High-g accelerometer full-scale selection**

FS_XL_HG [2:0]	Full scale [g]
000	±32
001	±64
010	±128
100	±256
011	Reserved

## 9.54 INTERNAL\_FREQ\_FINE (4Fh)

Internal frequency register (R)

**Table 151. INTERNAL\_FREQ\_FINE register**

FREQ_FINE_7	FREQ_FINE_6	FREQ_FINE_5	FREQ_FINE_4	FREQ_FINE_3	FREQ_FINE_2	FREQ_FINE_1	FREQ_FINE_0
-------------	-------------	-------------	-------------	-------------	-------------	-------------	-------------

**Table 152. INTERNAL\_FREQ\_FINE register description**

FREQ_FINE_[7:0]	Difference in percentage of the effective ODR (and timestamp rate) with respect to the typical. Step: 0.13%. 8-bit format, two's complement.
-----------------	--

The actual timestamp resolution and the actual output data rate can be calculated using the following formulas:

$$t_{actual}[s] = \frac{1}{46080 \cdot (1 + 0.0013 \cdot FREQ\_FINE)}$$

$$ODR_{actual}[Hz] = \frac{7680 \cdot (1 + 0.0013 \cdot FREQ\_FINE)}{ODR_{coeff}}$$

**Table 153. ODR<sub>coeff</sub> values**

Selected ODR [Hz]	ODR <sub>coeff</sub>
7.5	1024
15	512
30	256
60	128
120	64
240	32
480	16
960	8
1.92 kHz	4
3.84 kHz	2
7.68 kHz	1

## 9.55 FUNCTIONS\_ENABLE (50h)

Enable interrupt functions register (R/W)

**Table 154. FUNCTIONS\_ENABLE register**

INTERRUPTS_ENABLE	TIMESTAMP_EN	0 <sup>(1)</sup>	0 <sup>(1)</sup>	DIS_RST_LIR_ALL_INT	0 <sup>(1)</sup>	INACT_EN_1	INACT_EN_0
-------------------	--------------	------------------	------------------	---------------------	------------------	------------	------------

1. This bit must be set to 0 for the correct operation of the device.

**Table 155. FUNCTIONS\_ENABLE register description**

INTERRUPTS_ENABLE	Enables basic interrupts (6D/4D, free-fall, wake-up, tap, activity/inactivity). Default value: 0 (0: interrupt disabled; 1: interrupt enabled)
TIMESTAMP_EN	Enables timestamp counter. The counter is readable in <a href="#">TIMESTAMP0 (40h)</a> , <a href="#">TIMESTAMP1 (41h)</a> , <a href="#">TIMESTAMP2 (42h)</a> , and <a href="#">TIMESTAMP3 (43h)</a> . Default value: 0 (0: disabled; 1: enabled)
DIS_RST_LIR_ALL_INT	When this bit is set to 1, reading the <a href="#">ALL_INT_SRC (1Dh)</a> register does not reset the latched interrupt signals. This can be useful in order to not reset some status flags before reading the corresponding status register. Default value: 0 (0: disabled; 1: enabled)
INACT_EN_[1:0]	Enables activity/inactivity (sleep) function. Default value: 00 (00: stationary/motion-only interrupts generated, accelerometer and gyroscope configuration do not change; 01: sets accelerometer to low-power mode 1 with accelerometer ODR selected through the <a href="#">XL_INACT_ODR_[1:0]</a> bits of the <a href="#">INACTIVITY_DUR (54h)</a> register, gyroscope configuration does not change; 10: sets accelerometer to low-power mode 1 with accelerometer ODR selected through the <a href="#">XL_INACT_ODR_[1:0]</a> bits of the <a href="#">INACTIVITY_DUR (54h)</a> register, gyroscope in sleep mode; 11: sets accelerometer to low-power mode 1 with accelerometer ODR selected through the <a href="#">XL_INACT_ODR_[1:0]</a> bits of the <a href="#">INACTIVITY_DUR (54h)</a> register, gyroscope in power-down mode)

## 9.56 HG\_FUNCTIONS\_ENABLE (52h)

Enable high-g functions register (R/W)

**Table 156. HG\_FUNCTIONS\_ENABLE register**

HG_INTERRUPTS_ENABLE	HG_WU_CHANGE_INT_SEL	INT2_HG_WU	INT1_HG_WU	HG_SHOCK_DUR_3	HG_SHOCK_DUR_2	HG_SHOCK_DUR_1	HG_SHOCK_DUR_0
----------------------	----------------------	------------	------------	----------------	----------------	----------------	----------------

**Table 157. HG\_FUNCTIONS\_ENABLE register description**

HG_INTERRUPTS_ENABLE	Enables high-g interrupt generator (high-g wake-up and high-g shock). Default value: 0 (0: interrupt disabled; 1: interrupt enabled)
HG_WU_CHANGE_INT_SEL	Selects the type of wake-up interrupt to be sent to the INT1 pin, INT2 pin, and described by the HG_IA bit (ALL_INT_SRC (1Dh)). Default value: 0 (0: interrupt generated each time one of the three axes is higher than the threshold; 1: interrupt when high-g passes from all axes under the threshold to at least one axis over the threshold, or vice versa.)
INT2_HG_WU	Routes high-g wake-up event to INT2. Default value: 0 (0: routing high-g wake-up event to INT2 disabled; 1: routing high-g wake-up event to INT2 enabled)
INT1_HG_WU	Routes high-g wake-up event to INT1. Default value: 0 (0: routing high-g wake-up event to INT1 disabled; 1: routing high-g wake-up event to INT1 enabled)
HG_SHOCK_DUR_[3:0]	High-g duration to exit from shock state. Allowed values for HG_SHOCK_DUR_[3:0] are in the range of 0 (default) to 14. $HG\_SHOCK\_DUR[s] = (HG\_SHOCK\_DUR_{[3:0]} + 1) * 512 / ODR\_XL\_HG$

## 9.57 HG\_WAKE\_UP\_THS (53h)

High-g wake-up threshold register (R/W)

**Table 158. HG\_WAKE\_UP\_THS register**

HG_WK_THS_7	HG_WK_THS_6	HG_WK_THS_5	HG_WK_THS_4	HG_WK_THS_3	HG_WK_THS_2	HG_WK_THS_1	HG_WK_THS_0
-------------	-------------	-------------	-------------	-------------	-------------	-------------	-------------

**Table 159. HG\_WAKE\_UP\_THS register description**

HG_WK_THS_[7:0]	High-g wake-up threshold. The resolution of the threshold is 1 g/LSB. Default value: 000000
-----------------	---

## 9.58 INACTIVITY\_DUR (54h)

Activity/inactivity configuration register (R/W)

**Table 160. INACTIVITY\_DUR register**

SLEEP_STATUS_ON_INT	WU_INACT_THS_W_2	WU_INACT_THS_W_1	WU_INACT_THS_W_0	XL_INACT_ODR_1	XL_INACT_ODR_0	INACT_DUR_1	INACT_DUR_0
---------------------	------------------	------------------	------------------	----------------	----------------	-------------	-------------

**Table 161. INACTIVITY\_DUR register description**

SLEEP_STATUS_ON_INT	Activity/inactivity interrupt mode configuration. If the INT1_SLEEP_CHANGE or INT2_SLEEP_CHANGE bit is enabled, drives the sleep status or sleep change on the INT pin. Default value: 0 (0: sleep change notification on INT pin; 1: sleep status reported on INT pin)
WU_INACT_THS_W_[2:0]	Weight of 1 LSB of wake-up (WU_THS) and activity/inactivity (INACT_THS) threshold. (000: 7.8125 mg/LSB (default); 001: 15.625 mg/LSB; 010: 31.25 mg/LSB; 011: 62.5 mg/LSB; 100: 125 mg/LSB; 101 - 110 - 111: 250 mg/LSB)
XL_INACT_ODR_[1:0]	Selects the ODR_XL target during inactivity. (00: 1.875 Hz; 01: 15 Hz (default); 10: 30 Hz; 11: 60 Hz)
INACT_DUR_[1:0]	Duration in the transition from stationary to motion (from inactivity to activity). (00: transition to motion (activity) immediately at first overthreshold event (default); 01: transition to motion (activity) after two consecutive overthreshold events; 10: transition to motion (activity) after three consecutive overthreshold events; 11: transition to motion (activity) after four consecutive overthreshold events)

## 9.59 INACTIVITY\_THS (55h)

Activity/inactivity threshold setting register (R/W)

**Table 162. INACTIVITY\_THS register**

INT2_HG_SHOCK_CHANGE	INT1_HG_SHOCK_CHANGE	INACT_THS_5	INACT_THS_4	INACT_THS_3	INACT_THS_2	INACT_THS_1	INACT_THS_0
----------------------	----------------------	-------------	-------------	-------------	-------------	-------------	-------------

**Table 163. INACTIVITY\_THS register description**

INT2_HG_SHOCK_CHANGE	Routes high-g shock event to INT2. Default value: 0 (0: routing high-g shock event to INT2 disabled; 1: routing high-g shock event to INT2 enabled)
INT1_HG_SHOCK_CHANGE	Routes high-g shock event to INT1. Default value: 0 (0: routing high-g shock event to INT1 disabled; 1: routing high-g shock event to INT1 enabled)
INACT_THS_[5:0]	Activity/inactivity threshold. The resolution of the threshold depends on the value of WU_INACT_THS_W_[2:0] in the <b>INACTIVITY_DUR (54h)</b> register. Default value: 000000

## 9.60 TAP\_CFG0 (56h)

Tap configuration register 0 (R/W)

**Table 164. TAP\_CFG0 register**

0 <sup>(1)</sup>	LOW_PASS_ON_6D	HW_FUNC_MASK_XL_SETTL	SLOPE_FDS	TAP_X_EN	TAP_Y_EN	TAP_Z_EN	LIR
------------------	----------------	-----------------------	-----------	----------	----------	----------	-----

1. This bit must be set to 0 for the correct operation of the device.

**Table 165. TAP\_CFG0 register description**

LOW_PASS_ON_6D	LPF2 filter on 6D function selection. Refer to <a href="#">Figure 31</a> . Default value: 0 (0: ODR/2 low-pass filtered data sent to 6D interrupt function; 1: LPF2 output data sent to 6D interrupt function)
HW_FUNC_MASK_XL_SETTL	Enables masking the execution trigger of the basic interrupt functions (6D/4D, free-fall, wake-up, tap, activity/inactivity) when accelerometer data are settling. Default value: 0 (0: disabled; 1: enabled) <i>Note: Refer to the product application note for the details regarding operating/power mode configurations, settings, turn-on/off time and on-the-fly changes.</i>
SLOPE_FDS	HPF or slope filter selection on wake-up and activity/inactivity functions. Refer to <a href="#">Figure 31</a> . Default value: 0 (0: slope filter applied; 1: HPF applied)
TAP_X_EN	Enables X direction in tap recognition. Default value: 0 (0: X direction disabled; 1: X direction enabled)
TAP_Y_EN	Enables Y direction in tap recognition. Default value: 0 (0: Y direction disabled; 1: Y direction enabled)
TAP_Z_EN	Enables Z direction in tap recognition. Default value: 0 (0: Z direction disabled; 1: Z direction enabled)
LIR	Latched interrupt. Default value: 0 (0: interrupt request not latched; 1: interrupt request latched)

## 9.61 TAP\_CFG1 (57h)

Tap configuration register 1 (R/W)

**Table 166. TAP\_CFG1 register**

TAP_PRIORITY_2	TAP_PRIORITY_1	TAP_PRIORITY_0	TAP_THS_X_4	TAP_THS_X_3	TAP_THS_X_2	TAP_THS_X_1	TAP_THS_X_0
----------------	----------------	----------------	-------------	-------------	-------------	-------------	-------------

**Table 167. TAP\_CFG1 register description**

TAP_PRIORITY_[2:0]	Selection of axis priority for tap detection (see Table 168)
TAP_THS_X_[4:0]	X-axis tap recognition threshold. Default value: 0 1 LSB = FS_XL / (2 <sup>5</sup> )

**Table 168. TAP priority decoding**

TAP_PRIORITY_[2:0]	Max. priority	Mid. priority	Min. priority
000	X	Y	Z
001	Y	X	Z
010	X	Z	Y
011	Z	Y	X
100	X	Y	Z
101	Y	Z	X
110	Z	X	Y
111	Z	Y	X

## 9.62 TAP\_CFG2 (58h)

Tap configuration register 2 (R/W)

**Table 169. TAP\_CFG2 register**

0 <sup>(1)</sup>	0 <sup>(1)</sup>	0 <sup>(1)</sup>	TAP_THS_Y_4	TAP_THS_Y_3	TAP_THS_Y_2	TAP_THS_Y_1	TAP_THS_Y_0
------------------	------------------	------------------	-------------	-------------	-------------	-------------	-------------

1. This bit must be set to 0 for the correct operation of the device.

**Table 170. TAP\_CFG2 register description**

TAP_THS_Y_[4:0]	Y-axis tap recognition threshold. Default value: 0 1 LSB = FS_XL / (2 <sup>5</sup> )
-----------------	---

## 9.63 TAP\_THS\_6D (59h)

Portrait/landscape position and tap function threshold register (R/W)

**Table 171. TAP\_THS\_6D register**

D4D_EN	SIXD_THS_1	SIXD_THS_0	TAP_THS_Z_4	TAP_THS_Z_3	TAP_THS_Z_2	TAP_THS_Z_1	TAP_THS_Z_0
--------	------------	------------	-------------	-------------	-------------	-------------	-------------

**Table 172. TAP\_THS\_6D register description**

D4D_EN	Enables 4D orientation detection. Z-axis position detection is disabled. Default value: 0 (0: disabled; 1: enabled)
SIXD_THS_[1:0]	Threshold for 4D/6D function. Default value: 00 For details, refer to <a href="#">Table 173</a> .
TAP_THS_Z_[4:0]	Z-axis recognition threshold. Default value: 0 $1 \text{ LSB} = \text{FS\_XL} / (2^5)$

**Table 173. Threshold for D4D/D6D function**

SIXD_THS_[1:0]	Threshold value
00	80 degrees
01	70 degrees
10	60 degrees
11	50 degrees

## 9.64 TAP\_DUR (5Ah)

Tap recognition function setting register (R/W)

**Table 174. TAP\_DUR register**

DUR_3	DUR_2	DUR_1	DUR_0	QUIET_1	QUIET_0	SHOCK_1	SHOCK_0
-------	-------	-------	-------	---------	---------	---------	---------

**Table 175. TAP\_DUR register description**

DUR_[3:0]	Duration of maximum time gap for double-tap recognition. Default: 0000 When double-tap recognition is enabled, this register expresses the maximum time between two consecutive detected taps to determine a double-tap event. The default value of these bits is 0000b which corresponds to 16/ODR_XL time. If the DUR_[3:0] bits are set to a different value, 1LSB corresponds to 32/ODR_XL time.
QUIET_[1:0]	Expected quiet time after a tap detection. Default value: 00 Quiet time is the time after the first detected tap in which there must not be any overthreshold event. The default value of these bits is 00b which corresponds to 2/ODR_XL time. If the QUIET_[1:0] bits are set to a different value, 1LSB corresponds to 4/ODR_XL time.
SHOCK_[1:0]	Maximum duration of overthreshold event. Default value: 00 Maximum duration is the maximum time of an overthreshold signal detection to be recognized as a tap event. The default value of these bits is 00b which corresponds to 4/ODR_XL time. If the SHOCK_[1:0] bits are set to a different value, 1LSB corresponds to 8/ODR_XL time.

## 9.65 WAKE\_UP\_THS (5Bh)

Single/double-tap selection and wake-up configuration (R/W)

**Table 176. WAKE\_UP\_THS register**

SINGLE_ DOUBLE_TAP	USR_OFF_ ON_WU	WK_THS_5	WK_THS_4	WK_THS_3	WK_THS_2	WK_THS_1	WK_THS_0
--------------------	----------------	----------	----------	----------	----------	----------	----------

**Table 177. WAKE\_UP\_THS register description**

SINGLE_DOUBLE_TAP	Enables single/double-tap event. Default value: 0 (0: only single-tap event enabled; 1: both single and double-tap events enabled)
USR_OFF_ON_WU	Drives the low-pass filtered data with user offset correction (instead of high-pass filtered data) to the wake-up and the activity/inactivity functions. Refer to <a href="#">Figure 31</a> . Default value: 0
WK_THS_[5:0]	Wake-up threshold. The resolution of the threshold depends on the value of WU_INACT_THS_W_[2:0] in the <a href="#">INACTIVITY_DUR (54h)</a> register. Default value: 000000

## 9.66 WAKE\_UP\_DUR (5Ch)

Free-fall, wake-up, and sleep mode functions duration setting register (R/W)

**Table 178. WAKE\_UP\_DUR register**

FF_DUR_5	WAKE_DUR_1	WAKE_DUR_0	0 <sup>(1)</sup>	SLEEP_DUR_3	SLEEP_DUR_2	SLEEP_DUR_1	SLEEP_DUR_0
----------	------------	------------	------------------	-------------	-------------	-------------	-------------

1. This bit must be set to 0 for the correct operation of the device.

**Table 179. WAKE\_UP\_DUR register description**

FF_DUR_5	Free-fall duration event. Default: 0 For the complete configuration of the free-fall duration, refer to FF_DUR_[4:0] in the <b>FREE_FALL (5Dh)</b> configuration. 1 LSB = 1/ODR_XL time
WAKE_DUR_[1:0]	Wake-up duration event. Default: 00 1 LSB = 1/ODR_XL time
SLEEP_DUR_[3:0]	Duration to go in sleep mode. Default value: 0000 (this corresponds to 16 ODR) 1 LSB = 512/ODR_XL time

## 9.67 FREE\_FALL (5Dh)

Free-fall function duration setting register (R/W)

**Table 180. FREE\_FALL register**

FF_DUR_4	FF_DUR_3	FF_DUR_2	FF_DUR_1	FF_DUR_0	FF_THS_2	FF_THS_1	FF_THS_0
----------	----------	----------	----------	----------	----------	----------	----------

**Table 181. FREE\_FALL register description**

FF_DUR_[4:0]	Free-fall duration event. Default: 00000 For the complete configuration of the free-fall duration, refer to FF_DUR_5 in the <b>WAKE_UP_DUR (5Ch)</b> configuration.
FF_THS_[2:0]	Free-fall threshold setting. Default: 000 For details refer to <a href="#">Table 182</a> .

**Table 182. Threshold for free-fall function**

FF_THS_[2:0]	Threshold value
000	156 mg
001	219 mg
010	250 mg
011	312 mg
100	344 mg
101	406 mg
110	469 mg
111	500 mg

## 9.68 MD1\_CFG (5Eh)

Functions routing to INT1 pin register (R/W). Each bit in this register enables a signal to be carried over the INT1 pin. The output of the pin is the OR combination of the signals selected here and in the INT1\_CTRL (0Dh) register.

**Table 183. MD1\_CFG register**

INT1_SLEEP_CHANGE	INT1_SINGLE_TAP	INT1_WU	INT1_FF	INT1_DOUBLE_TAP	INT1_6D	INT1_EMB_FUNC	INT1_SHUB
-------------------	-----------------	---------	---------	-----------------	---------	---------------	-----------

**Table 184. MD1\_CFG register description**

INT1_SLEEP_CHANGE <sup>(1)</sup>	Routing activity/inactivity recognition event to INT1. Default: 0 (0: routing activity/inactivity event to INT1 disabled; 1: routing activity/inactivity event to INT1 enabled)
INT1_SINGLE_TAP	Routing single-tap recognition event to INT1. Default: 0 (0: routing single-tap event to INT1 disabled; 1: routing single-tap event to INT1 enabled)
INT1_WU	Routing wake-up event to INT1. Default value: 0 (0: routing wake-up event to INT1 disabled; 1: routing wake-up event to INT1 enabled)
INT1_FF	Routing free-fall event to INT1. Default value: 0 (0: routing free-fall event to INT1 disabled; 1: routing free-fall event to INT1 enabled)
INT1_DOUBLE_TAP	Routing tap event to INT1. Default value: 0 (0: routing double-tap event to INT1 disabled; 1: routing double-tap event to INT1 enabled)
INT1_6D	Routing 6D event to INT1. Default value: 0 (0: routing 6D event to INT1 disabled; 1: routing 6D event to INT1 enabled)
INT1_EMB_FUNC	Routing embedded functions event to INT1. Default value: 0 (0: routing embedded functions event to INT1 disabled; 1: routing embedded functions event to INT1 enabled)
INT1_SHUB	Routing sensor hub communication concluded event to INT1. Default value: 0 (0: routing sensor hub communication concluded event to INT1 disabled; 1: routing sensor hub communication concluded event to INT1 enabled)

1. Activity/inactivity interrupt mode (sleep change or sleep status) depends on the SLEEP\_STATUS\_ON\_INT bit in the INACTIVITY\_DUR (54h) register.

## 9.69 MD2\_CFG (5Fh)

Functions routing to INT2 pin register (R/W). Each bit in this register enables a signal to be carried over the INT2 pin. The output of the pin is the OR combination of the signals selected here and in the INT2\_CTRL (0Eh) register.

**Table 185. MD2\_CFG register**

INT2_SLEEP_CHANGE	INT2_SINGLE_TAP	INT2_WU	INT2_FF	INT2_DOUBLE_TAP	INT2_6D	INT2_EMB_FUNC	INT2_TIMESTAMP
-------------------	-----------------	---------	---------	-----------------	---------	---------------	----------------

**Table 186. MD2\_CFG register description**

INT2_SLEEP_CHANGE <sup>(1)</sup>	Routing activity/inactivity recognition event to INT2. Default: 0 (0: routing activity/inactivity event to INT2 disabled; 1: routing activity/inactivity event to INT2 enabled)
INT2_SINGLE_TAP	Single-tap recognition routing to INT2. Default: 0 (0: routing single-tap event to INT2 disabled; 1: routing single-tap event to INT2 enabled)
INT2_WU	Routing wake-up event to INT2. Default value: 0 (0: routing wake-up event to INT2 disabled; 1: routing wake-up event to INT2 enabled)
INT2_FF	Routing free-fall event to INT2. Default value: 0 (0: routing free-fall event to INT2 disabled; 1: routing free-fall event to INT2 enabled)
INT2_DOUBLE_TAP	Routing tap event to INT2. Default value: 0 (0: routing double-tap event to INT2 disabled; 1: routing double-tap event to INT2 enabled)
INT2_6D	Routing 6D event to INT2. Default value: 0 (0: routing 6D event to INT2 disabled; 1: routing 6D event to INT2 enabled)
INT2_EMB_FUNC	Routing embedded functions event to INT2. Default value: 0 (0: routing embedded functions event to INT2 disabled; 1: routing embedded functions event to INT2 enabled)
INT2_TIMESTAMP	Enables routing the alert for timestamp overflow within 5.6 ms to the INT2 pin.

1. Activity/inactivity interrupt mode (sleep change or sleep status) depends on the SLEEP\_STATUS\_ON\_INT bit in the INACTIVITY\_DUR (54h) register.

## 9.70 HAODR\_CFG (62h)

HAODR data rate configuration register (R/W)

**Table 187. HAODR\_CFG register**

0 <sup>(1)</sup>	0 <sup>(1)</sup>	0 <sup>(1)</sup>	0 <sup>(1)</sup>	0 <sup>(1)</sup>	0 <sup>(1)</sup>	HAODR_SEL_1	HAODR_SEL_0
------------------	------------------	------------------	------------------	------------------	------------------	-------------	-------------

1. This bit must be set to 0 for the correct operation of the device.

**Table 188. HAODR\_CFG register description**

HAODR_SEL_[1:0]	Selects the ODR set supported when high-accuracy ODR (HAODR) mode is enabled (see Table 22). Default: 00
-----------------	---

## 9.71 EMB\_FUNC\_CFG (63h)

Embedded functions configuration register (R/W)

**Table 189. EMB\_FUNC\_CFG register**

0 <sup>(1)</sup>	EMB_FUNC_IRQ_MASK_XL_HG_SETTL	EMB_FUNC_IRQ_MASK_G_SETTL	EMB_FUNC_IRQ_MASK_XL_SETTL	EMB_FUNC_DISABLE	0 <sup>(1)</sup>	0 <sup>(1)</sup>	0 <sup>(1)</sup>
------------------	-------------------------------	---------------------------	----------------------------	------------------	------------------	------------------	------------------

1. This bit must be set to 0 for the correct operation of the device.

**Table 190. EMB\_FUNC\_CFG register description**

EMB_FUNC_IRQ_MASK_XL_HG_SETTL	<p>Enables / masks the execution trigger of the embedded functions when the high-g accelerometer data are settling. Default value: 0</p> <p>(0: disabled;</p> <p>1: masks the execution trigger of the embedded functions until the high-g accelerometer filter settling ends)</p> <p><i>Note: Refer to the product application note for the details regarding operating/ power mode configurations, settings, turn-on/off time, and on-the-fly changes.</i></p>
EMB_FUNC_IRQ_MASK_G_SETTL	<p>Enables / masks the execution trigger of the embedded functions when the gyroscope data are settling. Default value: 0</p> <p>(0: disabled;</p> <p>1: masks the execution trigger of the embedded functions until the gyroscope filter settling ends)</p> <p><i>Note: Refer to the product application note for the details regarding operating/ power mode configurations, settings, turn-on/off time, and on-the-fly changes.</i></p>
EMB_FUNC_IRQ_MASK_XL_SETTL	<p>Enables / masks the execution trigger of the embedded functions when the low-g accelerometer data are settling. Default value: 0</p> <p>(0: disabled;</p> <p>1: masks the execution trigger of the embedded functions until the low-g accelerometer filter settling ends)</p> <p><i>Note: Refer to the product application note for the details regarding operating/ power mode configurations, settings, turn-on/off time, and on-the-fly changes.</i></p>
EMB_FUNC_DISABLE	<p>Disables execution of the embedded functions. Default value: 0</p> <p>(0: execution of the embedded functions is enabled;</p> <p>1: execution trigger of the embedded functions is not generated anymore and all initialization procedures are forced when this bit is set back to 0).</p>

## 9.72 UI\_HANDSHAKE\_CTRL (64h)

Control register (UI side) for UI / IF2 shared registers (R/W)

**Table 191. UI\_HANDSHAKE\_CTRL register**

0 <sup>(1)</sup>	0 <sup>(1)</sup>	0 <sup>(1)</sup>	0 <sup>(1)</sup>	0 <sup>(1)</sup>	0 <sup>(1)</sup>	UI_SHARED_ACK	UI_SHARED_REQ
------------------	------------------	------------------	------------------	------------------	------------------	---------------	---------------

1. This bit must be set to 0 for the correct operation of the device.

**Table 192. UI\_HANDSHAKE\_CTRL register description**

UI_SHARED_ACK	<p>Primary interface side. This bit acknowledges the handshake. If the secondary interface is not accessing the shared registers, this bit is set to 1 by the device and the R/W operation on the UI_IF2_SHARED_0 (65h) through UI_IF2_SHARED_5 (6Ah) registers is allowed on the primary interface.</p>
UI_SHARED_REQ	<p>This bit is used by the primary interface controller to request access to the UI_IF2_SHARED_0 (65h) through UI_IF2_SHARED_5 (6Ah) registers. When the R/W operation is finished, the controller must reset this bit.</p>

### 9.73 UI\_IF2\_SHARED\_0 (65h)

UI / IF2 shared register 0 (R/W)

**Table 193. UI\_IF2\_SHARED\_0 register**

D7	D6	D5	D4	D3	D2	D1	D0
----	----	----	----	----	----	----	----

**Table 194. UI\_IF2\_SHARED\_0 register description**

D[7:0]	Volatile byte is used as a contact point between the primary and secondary interface host. These shared registers are accessible only by one interface at a time and access is managed through the UI_SHARED_ACK and UI_SHARED_REQ bits of register UI_HANDSHAKE_CTRL (64h) and the IF2_SHARED_ACK and IF2_SHARED_REQ bits of register IF2_HANDSHAKE_CTRL (6Eh).
--------	--

### 9.74 UI\_IF2\_SHARED\_1 (66h)

UI / IF2 shared register 1 (R/W)

**Table 195. UI\_IF2\_SHARED\_1 register**

D7	D6	D5	D4	D3	D2	D1	D0
----	----	----	----	----	----	----	----

**Table 196. UI\_IF2\_SHARED\_1 register description**

D[7:0]	Volatile byte is used as a contact point between the primary and secondary interface host. These shared registers are accessible only by one interface at a time and access is managed through the UI_SHARED_ACK and UI_SHARED_REQ bits of register UI_HANDSHAKE_CTRL (64h) and the IF2_SHARED_ACK and IF2_SHARED_REQ bits of register IF2_HANDSHAKE_CTRL (6Eh).
--------	--

### 9.75 UI\_IF2\_SHARED\_2 (67h)

UI / IF2 shared register 2 (R/W)

**Table 197. UI\_IF2\_SHARED\_2 register**

D7	D6	D5	D4	D3	D2	D1	D0
----	----	----	----	----	----	----	----

**Table 198. UI\_IF2\_SHARED\_2 register description**

D[7:0]	Volatile byte is used as a contact point between the primary and secondary interface host. These shared registers are accessible only by one interface at a time and access is managed through the UI_SHARED_ACK and UI_SHARED_REQ bits of register UI_HANDSHAKE_CTRL (64h) and the IF2_SHARED_ACK and IF2_SHARED_REQ bits of register IF2_HANDSHAKE_CTRL (6Eh).
--------	--

### 9.76 UI\_IF2\_SHARED\_3 (68h)

UI / IF2 shared register 3 (R/W)

**Table 199. UI\_IF2\_SHARED\_3 register**

D7	D6	D5	D4	D3	D2	D1	D0
----	----	----	----	----	----	----	----

**Table 200. UI\_IF2\_SHARED\_3 register description**

D[7:0]	Volatile byte is used as a contact point between the primary and secondary interface host. These shared registers are accessible only by one interface at a time and access is managed through the UI_SHARED_ACK and UI_SHARED_REQ bits of register UI_HANDSHAKE_CTRL (64h) and the IF2_SHARED_ACK and IF2_SHARED_REQ bits of register IF2_HANDSHAKE_CTRL (6Eh).
--------	--

### 9.77 UI\_IF2\_SHARED\_4 (69h)

UI / IF2 shared register 4 (R/W)

**Table 201. UI\_IF2\_SHARED\_4 register**

D7	D6	D5	D4	D3	D2	D1	D0
----	----	----	----	----	----	----	----

**Table 202. UI\_IF2\_SHARED\_4 register description**

D[7:0]	Volatile byte is used as a contact point between the primary and secondary interface host. These shared registers are accessible only by one interface at a time and access is managed through the UI_SHARED_ACK and UI_SHARED_REQ bits of register UI_HANDSHAKE_CTRL (64h) and the IF2_SHARED_ACK and IF2_SHARED_REQ bits of register IF2_HANDSHAKE_CTRL (6Eh).
--------	--

### 9.78 UI\_IF2\_SHARED\_5 (6Ah)

UI / IF2 shared register 5 (R/W)

**Table 203. UI\_IF2\_SHARED\_5 register**

D7	D6	D5	D4	D3	D2	D1	D0
----	----	----	----	----	----	----	----

**Table 204. UI\_IF2\_SHARED\_5 register description**

D[7:0]	Volatile byte is used as a contact point between the primary and secondary interface host. These shared registers are accessible only by one interface at a time and access is managed through the UI_SHARED_ACK and UI_SHARED_REQ bits of register UI_HANDSHAKE_CTRL (64h) and the IF2_SHARED_ACK and IF2_SHARED_REQ bits of register IF2_HANDSHAKE_CTRL (6Eh).
--------	--

## 9.79 CTRL\_EIS (6Bh)

Gyroscope EIS channel control register (R/W)

**Table 205. CTRL\_EIS register**

ODR_G_EIS_1	ODR_G_EIS_0	0 <sup>(1)</sup>	LPF_G_EIS_BW	G_EIS_ON_G_OIS_OUT_REG	FS_G_EIS_2	FS_G_EIS_1	FS_G_EIS_0
-------------	-------------	------------------	--------------	------------------------	------------	------------	------------

1. This bit must be set to 0 for the correct operation of the device.

**Table 206. CTRL\_EIS register description**

ODR_G_EIS_[1:0]	Enables and selects the ODR of the gyroscope EIS channel. (00: EIS channel is off (default); 01: 1.92 kHz; 10: 960 Hz; 11: reserved)
LPF_G_EIS_BW	Gyroscope digital LPF_EIS filter bandwidth selection. Refer to Table 207.
G_EIS_ON_G_OIS_OUT_REG	Enables routing gyroscope EIS output to OIS from UI output addresses (2Eh – 33h). When this bit is set to 1, the gyroscope OIS data cannot be read from primary interface. Default value: 0 (0: disabled; 1: enabled)
FS_G_EIS_[2:0] <sup>(1)</sup>	Gyroscope full-scale selection for EIS channel. If the FS_G_[3:0] bits in CTRL6 (15h) are equal to 1100 (±4000 dps), FS_G_EIS_[2:0] must be set to 100 in order to have ±4000 dps full scale on both UI and EIS channels. If the FS_G_3 bit in register CTRL6 (15h) is equal to 0, the EIS channel full scale can be selected as follows: (000: reserved (default); 001: ±250 dps; 010: ±500 dps; 011: ±1000 dps; 100: ±2000 dps; 101: reserved; 110: reserved; 111: reserved)

1. The default configuration of FS\_G\_EIS\_[2:0] is 000 (reserved). For the correct operation of the device, the user must set a configuration from 001 to 100 when the gyroscope is in power-down mode.

**Table 207. Gyroscope EIS chain digital LPF\_EIS filter bandwidth selection**

ODR_G_EIS_[1:0]	Gyroscope EIS ODR [Hz]	LPF_G_EIS_BW	Cutoff [Hz]	Phase @ 20 Hz [°]
01	1.92 kHz	0	153 Hz	-13.5°
		1	203 Hz	-10.8°
10	960	0	148 Hz	-15.4°
		1	193 Hz	-12.7°

## 9.80 XL\_HG\_X\_OFS\_USR (6Ch)

High-g accelerometer X-axis user offset correction (R/W). The offset value set in the XL\_HG\_X\_OFS\_USR offset register is internally subtracted from the acceleration value measured on the X-axis.

**Table 208. XL\_HG\_X\_OFS\_USR register**

XL_HG_X_OFS_USR_7	XL_HG_X_OFS_USR_6	XL_HG_X_OFS_USR_5	XL_HG_X_OFS_USR_4	XL_HG_X_OFS_USR_3	XL_HG_X_OFS_USR_2	XL_HG_X_OFS_USR_1	XL_HG_X_OFS_USR_0
-------------------	-------------------	-------------------	-------------------	-------------------	-------------------	-------------------	-------------------

**Table 209. XL\_HG\_X\_OFS\_USR register description**

XL_HG_X_OFS_USR_[7:0]	High-g accelerometer X-axis user offset expressed in two's complement, weight is 0.25 g/LSB. The value must be in the range [-127 127].
-----------------------	---

## 9.81 XL\_HG\_Y\_OFS\_USR (6Dh)

High-g accelerometer Y-axis user offset correction (R/W). The offset value set in the XL\_HG\_Y\_OFS\_USR offset register is internally subtracted from the acceleration value measured on the Y-axis.

**Table 210. XL\_HG\_Y\_OFS\_USR register**

XL_HG_Y_OFS_USR_7	XL_HG_Y_OFS_USR_6	XL_HG_Y_OFS_USR_5	XL_HG_Y_OFS_USR_4	XL_HG_Y_OFS_USR_3	XL_HG_Y_OFS_USR_2	XL_HG_Y_OFS_USR_1	XL_HG_Y_OFS_USR_0
-------------------	-------------------	-------------------	-------------------	-------------------	-------------------	-------------------	-------------------

**Table 211. XL\_HG\_Y\_OFS\_USR register description**

XL_HG_Y_OFS_USR_[7:0]	High-g accelerometer Y-axis user offset expressed in two's complement, weight is 0.25 g/LSB. The value must be in the range [-127 127].
-----------------------	---

## 9.82 XL\_HG\_Z\_OFS\_USR (6Eh)

High-g accelerometer Z-axis user offset correction (R/W). The offset value set in the XL\_HG\_Z\_OFS\_USR offset register is internally subtracted from the acceleration value measured on the Z-axis.

**Table 212. XL\_HG\_Z\_OFS\_USR register**

XL_HG_Z_OFS_USR_7	XL_HG_Z_OFS_USR_6	XL_HG_Z_OFS_USR_5	XL_HG_Z_OFS_USR_4	XL_HG_Z_OFS_USR_3	XL_HG_Z_OFS_USR_2	XL_HG_Z_OFS_USR_1	XL_HG_Z_OFS_USR_0
-------------------	-------------------	-------------------	-------------------	-------------------	-------------------	-------------------	-------------------

**Table 213. XL\_HG\_Z\_OFS\_USR register description**

XL_HG_Z_OFS_USR_[7:0]	High-g accelerometer Z-axis user offset expressed in two's complement, weight is 0.25 g/LSB. The value must be in the range [-127 127].
-----------------------	---

## 9.83 UI\_INT\_OIS (6Fh)

OIS interrupt configuration register

The primary interface can write to this register when the OIS\_CTRL\_FROM\_UI bit in the FUNC\_CFG\_ACCESS (01h) register is equal to 1 (primary IF full-control mode); this register is read-only when the OIS\_CTRL\_FROM\_UI bit is equal to 0 (auxiliary interface full-control mode) and shows the content of the IF2\_INT\_OIS (6Fh) register.

**Table 214. UI\_INT\_OIS register**

INT2_DRDY_OIS	DRDY_MASK_OIS	0 <sup>(1)</sup>	ST_OIS_CLAMPDIS	0 <sup>(1)</sup>	0 <sup>(1)</sup>	0 <sup>(1)</sup>	0 <sup>(1)</sup>
---------------	---------------	------------------	-----------------	------------------	------------------	------------------	------------------

1. This bit must be set to 0 for the correct operation of the device.

**Table 215. UI\_INT\_OIS register description**

INT2_DRDY_OIS	Enables OIS chain DRDY on INT2 pin from the UI interface. This setting has priority over all other INT2 settings.
DRDY_MASK_OIS	Enables / masks OIS data available. Default value: 0 (0: disabled; 1: masks OIS DRDY signals (both accelerometer and gyroscope) until filter settling ends (accelerometer and gyroscope independently masked))
ST_OIS_CLAMPDIS	Disables OIS chain clamp during self-test. Default value: 0 (0: All OIS chain outputs = 8000h during self-test; 1: OIS chain self-test outputs)

## 9.84 UI\_CTRL1\_OIS (70h)

OIS configuration register

The primary interface can write this register when the OIS\_CTRL\_FROM\_UI bit in the FUNC\_CFG\_ACCESS (01h) register is equal to 1 (primary IF full-control mode); this register is read-only when the OIS\_CTRL\_FROM\_UI bit is equal to 0 (auxiliary interface full-control mode) and shows the content of the IF2\_CTRL1\_OIS (70h) register.

**Table 216. UI\_CTRL1\_OIS register**

0 <sup>(1)</sup>	0 <sup>(1)</sup>	SIM_OIS	0 <sup>(1)</sup>	0 <sup>(1)</sup>	OIS_XL_EN	OIS_G_EN	AUX_SPI_READ_EN
------------------	------------------	---------	------------------	------------------	-----------	----------	-----------------

1. This bit must be set to 0 for the correct operation of the device.

**Table 217. UI\_CTRL1\_OIS register description**

SIM_OIS	Auxiliary SPI 3- or 4-wire interface. Default value: 0 (0: 4-wire auxiliary SPI; 1: 3-wire auxiliary SPI)
OIS_XL_EN	Enables accelerometer OIS chain. Default value: 0 (0: accelerometer OIS chain disabled; 1: accelerometer OIS chain enabled)
OIS_G_EN	Enables gyroscope OIS chain. Default value: 0 (0: gyroscope OIS chain disabled; 1: gyroscope OIS chain enabled)
AUX_SPI_READ_EN	Selection between auxiliary SPI or auxiliary I3C. Default value: 0 (0: OIS data read from auxiliary SPI disabled and I3C auxiliary enabled; 1: OIS data read from auxiliary SPI enabled and I3C auxiliary disabled)

## 9.85 UI\_CTRL2\_OIS (71h)

OIS configuration register

The primary interface can write this register when the OIS\_CTRL\_FROM\_UI bit in the FUNC\_CFG\_ACCESS (01h) register is equal to 1 (primary IF full-control mode); this register is read-only when the OIS\_CTRL\_FROM\_UI bit is equal to 0 (auxiliary interface full-control mode) and shows the content of the IF2\_CTRL2\_OIS (71h) register.

**Table 218. UI\_CTRL2\_OIS register**

0 <sup>(1)</sup>	0 <sup>(1)</sup>	0 <sup>(1)</sup>	LPF1_G_OIS_BW_1	LPF1_G_OIS_BW_0	FS_G_OIS_2	FS_G_OIS_1	FS_G_OIS_0
------------------	------------------	------------------	-----------------	-----------------	------------	------------	------------

1. This bit must be set to 0 for the correct operation of the device.

**Table 219. UI\_CTRL2\_OIS register description**

LPF1_G_OIS_BW_[1:0]	Gyroscope OIS digital LPF1 filter bandwidth selection. Refer to Table 220.
FS_G_OIS_[2:0]	Gyroscope OIS full-scale selection: (000: reserved; 001: ±250 dps; 010: ±500 dps; 011: ±1000 dps; 100: ±2000 dps; 101: reserved; 110: reserved; 111: reserved)

**Table 220. Gyroscope OIS chain digital LPF1 filter bandwidth selection**

LPF1_G_OIS_BW_[1:0]	Cutoff [Hz]	Phase @ 20 Hz [°]
00	293 Hz	-7.1°
01	217 Hz	-9.1°
10	158 Hz	-11.9°
11	476 Hz	-5.1°

## 9.86 UI\_CTRL3\_OIS (72h)

OIS configuration register

The primary interface can write this register when the OIS\_CTRL\_FROM\_UI bit in the FUNC\_CFG\_ACCESS (01h) register is equal to 1 (primary IF full-control mode); this register is read-only when the OIS\_CTRL\_FROM\_UI bit is equal to 0 (auxiliary interface full-control mode) and shows the content of the IF2\_CTRL3\_OIS (72h) register.

**Table 221. UI\_CTRL3\_OIS register**

0 <sup>(1)</sup>	0 <sup>(1)</sup>	LPF_XL_OIS_BW_2	LPF_XL_OIS_BW_1	LPF_XL_OIS_BW_0	0 <sup>(1)</sup>	FS_XL_OIS_1	FS_XL_OIS_0
------------------	------------------	-----------------	-----------------	-----------------	------------------	-------------	-------------

1. This bit must be set to 0 for the correct operation of the device.

**Table 222. UI\_CTRL3\_OIS register description**

LPF_XL_OIS_BW_[2:0]	Selects accelerometer OIS channel bandwidth, see Table 223. Default value: 0
FS_XL_OIS_[1:0]	Selects accelerometer OIS channel full-scale: (00: ±2 g (default); 01: ±4 g; 10: ±8 g; 11: ±16 g)

*Note:* When the accelerometer full-scale value is selected only from the UI side it is readable also from the OIS side.

**Table 223. Accelerometer OIS channel bandwidth and phase**

LPF_XL_OIS_BW_[2:0]	Typ. overall bandwidth [Hz]	Typ. overall phase [°]
000	749 Hz	-3.41 deg @ 20 Hz
001	539 Hz	-4.04 deg @ 20 Hz
010	342 Hz	-5.31 deg @ 20 Hz
011	162 Hz	-9.08 deg @ 20 Hz
100	78.5 Hz	-16.4 deg @ 20 Hz
101	38.6 Hz	-29.6 deg @ 20 Hz
110	19.3 Hz	-28.8 deg @ 10 Hz
111	9.8 Hz	-29.1 deg @ 5 Hz

### 9.87 X\_OFS\_USR (73h)

Accelerometer X-axis user offset correction (R/W). The offset value set in the X\_OFS\_USR offset register is internally subtracted from the acceleration value measured on the X-axis.

**Table 224. X\_OFS\_USR register**

X_OFS_USR_7	X_OFS_USR_6	X_OFS_USR_5	X_OFS_USR_4	X_OFS_USR_3	X_OFS_USR_2	X_OFS_USR_1	X_OFS_USR_0
-------------	-------------	-------------	-------------	-------------	-------------	-------------	-------------

**Table 225. X\_OFS\_USR register description**

X_OFS_USR_[7:0]	Accelerometer X-axis user offset correction expressed in two's complement, weight depends on USR_OFF_W in CTRL9 (18h). The offset can be applied to the output registers (see USR_OFF_ON_OUT bit in the CTRL9 (18h) register) or to the wake-up function input data (see USR_OFF_ON_WU bit in the WAKE_UP_THS (5Bh) register). The value must be in the range [-127 127].
-----------------	---

### 9.88 Y\_OFS\_USR (74h)

Accelerometer Y-axis user offset correction (R/W). The offset value set in the Y\_OFS\_USR offset register is internally subtracted from the acceleration value measured on the Y-axis.

**Table 226. Y\_OFS\_USR register**

Y_OFS_USR_7	Y_OFS_USR_6	Y_OFS_USR_5	Y_OFS_USR_4	Y_OFS_USR_3	Y_OFS_USR_2	Y_OFS_USR_1	Y_OFS_USR_0
-------------	-------------	-------------	-------------	-------------	-------------	-------------	-------------

**Table 227. Y\_OFS\_USR register description**

Y_OFS_USR_[7:0]	Accelerometer Y-axis user offset correction expressed in two's complement, weight depends on USR_OFF_W in CTRL9 (18h). The offset can be applied to the output registers (see USR_OFF_ON_OUT bit in the CTRL9 (18h) register) or to the wake-up function input data (see USR_OFF_ON_WU bit in the WAKE_UP_THS (5Bh) register). The value must be in the range [-127 127].
-----------------	---

### 9.89 Z\_OFS\_USR (75h)

Accelerometer Z-axis user offset correction (R/W). The offset value set in the Z\_OFS\_USR offset register is internally subtracted from the acceleration value measured on the Z-axis.

**Table 228. Z\_OFS\_USR register**

Z_OFS_USR_7	Z_OFS_USR_6	Z_OFS_USR_5	Z_OFS_USR_4	Z_OFS_USR_3	Z_OFS_USR_2	Z_OFS_USR_1	Z_OFS_USR_0
-------------	-------------	-------------	-------------	-------------	-------------	-------------	-------------

**Table 229. Z\_OFS\_USR register description**

Z_OFS_USR_[7:0]	Accelerometer Z-axis user offset correction expressed in two's complement, weight depends on USR_OFF_W in CTRL9 (18h). The offset can be applied to the output registers (see USR_OFF_ON_OUT bit in the CTRL9 (18h) register) or to the wake-up function input data (see USR_OFF_ON_WU bit in the WAKE_UP_THS (5Bh) register). The value must be in the range [-127 127].
-----------------	---

## 9.90 FIFO\_DATA\_OUT\_TAG (78h)

FIFO tag register (R)

**Table 230. FIFO\_DATA\_OUT\_TAG register**

TAG_SENSOR_4	TAG_SENSOR_3	TAG_SENSOR_2	TAG_SENSOR_1	TAG_SENSOR_0	TAG_CNT_1	TAG_CNT_0	-
--------------	--------------	--------------	--------------	--------------	-----------	-----------	---

**Table 231. FIFO\_DATA\_OUT\_TAG register description**

TAG_SENSOR_[4:0]	FIFO tag. Identifies the sensor in: FIFO_DATA_OUT_X_L (79h) and FIFO_DATA_OUT_X_H (7Ah), FIFO_DATA_OUT_Y_L (7Bh) and FIFO_DATA_OUT_Y_H (7Ch), and FIFO_DATA_OUT_Z_L (7Dh) and FIFO_DATA_OUT_Z_H (7Eh) For details, refer to Table 232.
TAG_CNT_[1:0]	2-bit counter which identifies sensor time slot

**Table 232. FIFO tag**

TAG_SENSOR_[4:0]	Sensor name
0x00	FIFO empty
0x01	Gyroscope NC
0x02	Accelerometer NC
0x03	Temperature
0x04	Timestamp
0x05	CFG_Change
0x06	Accelerometer NC_T_2
0x07	Accelerometer NC_T_1
0x08	Accelerometer 2xC
0x09	Accelerometer 3xC
0x0A	Gyroscope NC_T_2
0x0B	Gyroscope NC_T_1
0x0C	Gyroscope 2xC
0x0D	Gyroscope 3xC
0x0E	Sensor hub target 0
0x0F	Sensor hub target 1
0x10	Sensor hub target 2
0x11	Sensor hub target 3
0x12	Step counter
0x13	SFLP game rotation vector
0x16	SFLP gyroscope bias
0x17	SFLP gravity vector
0x18	High-g accelerometer peak value
0x19	Sensor hub nack
0x1A	MLC result
0x1B	MLC filter
0x1C	MLC feature
0x1D	High-g accelerometer
0x1E	Enhanced EIS gyroscope

### 9.91 FIFO\_DATA\_OUT\_X\_L (79h) and FIFO\_DATA\_OUT\_X\_H (7Ah)

FIFO data output X (R)

**Table 233.** FIFO\_DATA\_OUT\_X\_H and FIFO\_DATA\_OUT\_X\_L registers

D15	D14	D13	D12	D11	D10	D9	D8
D7	D6	D5	D4	D3	D2	D1	D0

**Table 234.** FIFO\_DATA\_OUT\_X\_H and FIFO\_DATA\_OUT\_X\_L register description

D[15:0]	FIFO X-axis output
---------	--------------------

### 9.92 FIFO\_DATA\_OUT\_Y\_L (7Bh) and FIFO\_DATA\_OUT\_Y\_H (7Ch)

FIFO data output Y (R)

**Table 235.** FIFO\_DATA\_OUT\_Y\_H and FIFO\_DATA\_OUT\_Y\_L registers

D15	D14	D13	D12	D11	D10	D9	D8
D7	D6	D5	D4	D3	D2	D1	D0

**Table 236.** FIFO\_DATA\_OUT\_Y\_H and FIFO\_DATA\_OUT\_Y\_L register description

D[15:0]	FIFO Y-axis output
---------	--------------------

### 9.93 FIFO\_DATA\_OUT\_Z\_L (7Dh) and FIFO\_DATA\_OUT\_Z\_H (7Eh)

FIFO data output Z (R)

**Table 237.** FIFO\_DATA\_OUT\_Z\_H and FIFO\_DATA\_OUT\_Z\_L registers

D15	D14	D13	D12	D11	D10	D9	D8
D7	D6	D5	D4	D3	D2	D1	D0

**Table 238.** FIFO\_DATA\_OUT\_Z\_H and FIFO\_DATA\_OUT\_Z\_L register description

D[15:0]	FIFO Z-axis output
---------	--------------------

## 10 IF2 register mapping

The table given below provides a list of the 8/16-bit registers embedded in the device and the corresponding addresses.

All these registers are accessible from the auxiliary interface only.

**Table 239. IF2 register address map**

Name	Type	Register address		Default	Comment
		Hex	Binary		
IF2_WHO_AM_I	R	0F	00001111	01110011	
IF2_STATUS_REG_OIS	R	1E	00011110	output	
IF2_OUT_TEMP_L	R	20	00100000	output	
IF2_OUT_TEMP_H	R	21	00100001	output	
IF2_OUTX_L_G_OIS	R	22	00100010	output	
IF2_OUTX_H_G_OIS	R	23	00100011	output	
IF2_OUTY_L_G_OIS	R	24	00100100	output	
IF2_OUTY_H_G_OIS	R	25	00100101	output	
IF2_OUTZ_L_G_OIS	R	26	00100110	output	
IF2_OUTZ_H_G_OIS	R	27	00100111	output	
IF2_OUTX_L_A_OIS	R	28	00101000	output	
IF2_OUTX_H_A_OIS	R	29	00101001	output	
IF2_OUTY_L_A_OIS	R	2A	00101010	output	
IF2_OUTY_H_A_OIS	R	2B	00101011	output	
IF2_OUTZ_L_A_OIS	R	2C	00101100	output	
IF2_OUTZ_H_A_OIS	R	2D	00101101	output	
IF2_HANDSHAKE_CTRL	R/W	6E	01101110	00000000	
IF2_INT_OIS	R/W (auxiliary IF full-control mode) R (primary IF full-control mode)	6F	01101111	00000000	
IF2_CTRL1_OIS	R/W (auxiliary IF full-control mode) R (primary IF full-control mode)	70	01110000	00000000	
IF2_CTRL2_OIS	R/W (auxiliary IF full-control mode) R (primary IF full-control mode)	71	01110001	00000000	
IF2_CTRL3_OIS	R/W (auxiliary IF full-control mode) R (primary IF full-control mode)	72	01110010	00000000	

Reserved registers must not be changed. Writing to those registers may cause permanent damage to the device. The content of the registers that are loaded at boot should not be changed. They contain the factory calibration values. Their content is automatically restored when the device is powered up.

## 11 IF2 register description

### 11.1 IF2\_WHO\_AM\_I (0Fh)

WHO\_AM\_I register (R). This is a read-only register. Its value is fixed at 73h.

**Table 240. IF2\_WhoAml register**

0	1	1	1	0	0	1	1
---	---	---	---	---	---	---	---

### 11.2 IF2\_STATUS\_REG\_OIS (1Eh)

The IF2\_STATUS\_REG\_OIS register is read by the auxiliary interface (R).

**Table 241. IF2\_STATUS\_REG\_OIS register**

0	0	0	0	0	GYRO_SETTLING	GDA	XLDA
---	---	---	---	---	---------------	-----	------

**Table 242. IF2\_STATUS\_REG\_OIS description**

GYRO_SETTLING	High when the gyroscope output is in the settling phase
GDA	Gyroscope data available (reset when one of the high bytes of the output data is read)
XLDA	Accelerometer data available (reset when one of the high bytes of the output data is read)

### 11.3 IF2\_OUT\_TEMP\_L (20h) and IF2\_OUT\_TEMP\_H (21h)

Temperature data output register (R). L and H registers together express a 16-bit word in two's complement.

**Table 243. IF2\_OUT\_TEMP\_L register**

Temp7	Temp6	Temp5	Temp4	Temp3	Temp2	Temp1	Temp0
-------	-------	-------	-------	-------	-------	-------	-------

**Table 244. IF2\_OUT\_TEMP\_H register**

Temp15	Temp14	Temp13	Temp12	Temp11	Temp10	Temp9	Temp8
--------	--------	--------	--------	--------	--------	-------	-------

**Table 245. IF2\_OUT\_TEMP register description**

Temp[15:0]	Temperature sensor output data The value is expressed as two's complement sign extended on the MSB.
------------	--

### 11.4 IF2\_OUTX\_L\_G\_OIS (22h) and IF2\_OUTX\_H\_G\_OIS (23h)

Angular rate sensor pitch axis (X) angular rate output register (R). The value is expressed as a 16-bit word in two's complement.

Data are according to the gyroscope full-scale and ODR (7.68 kHz) settings of the OIS gyroscope.

**Table 246. IF2\_OUTX\_L\_G\_OIS register**

D7	D6	D5	D4	D3	D2	D1	D0
----	----	----	----	----	----	----	----

**Table 247. IF2\_OUTX\_H\_G\_OIS register**

D15	D14	D13	D12	D11	D10	D9	D8
-----	-----	-----	-----	-----	-----	----	----

**Table 248. IF2\_OUTX\_H\_G\_OIS register description**

D[15:0]	Gyroscope OIS chain pitch axis (X) angular rate output value
---------	--

### 11.5 IF2\_OUTY\_L\_G\_OIS (24h) and IF2\_OUTY\_H\_G\_OIS (25h)

Angular rate sensor roll axis (Y) angular rate output register (R). The value is expressed as a 16-bit word in two's complement.

Data are according to the gyroscope full-scale and ODR (7.68 kHz) settings of the OIS gyroscope.

**Table 249. IF2\_OUTY\_L\_G\_OIS register**

D7	D6	D5	D4	D3	D2	D1	D0
----	----	----	----	----	----	----	----

**Table 250. IF2\_OUTY\_H\_G\_OIS register**

D15	D14	D13	D12	D11	D10	D9	D8
-----	-----	-----	-----	-----	-----	----	----

**Table 251. IF2\_OUTY\_H\_G\_OIS register description**

D[15:0]	Gyroscope OIS chain roll axis (Y) angular rate output value
---------	---

## 11.6 IF2\_OUTZ\_L\_G\_OIS (26h) and IF2\_OUTZ\_H\_G\_OIS (27h)

Angular rate sensor yaw axis (Z) angular rate output register (R). The value is expressed as a 16-bit word in two's complement.

Data are according to the gyroscope full-scale and ODR (7.68 kHz) settings of the OIS gyroscope.

**Table 252. IF2\_OUTZ\_L\_G\_OIS register**

D7	D6	D5	D4	D3	D2	D1	D0
----	----	----	----	----	----	----	----

**Table 253. IF2\_OUTZ\_H\_G\_OIS register**

D15	D14	D13	D12	D11	D10	D9	D8
-----	-----	-----	-----	-----	-----	----	----

**Table 254. IF2\_OUTZ\_H\_G\_OIS register description**

D[15:0]	Gyroscope OIS chain yaw axis (Z) angular rate output value
---------	--

## 11.7 IF2\_OUTX\_L\_A\_OIS (28h) and IF2\_OUTX\_H\_A\_OIS (29h)

Linear acceleration sensor X-axis output register (R). The value is expressed as a 16-bit word in two's complement.

Data are according to the accelerometer full-scale and ODR (7.68 kHz) settings of the OIS accelerometer.

**Table 255. IF2\_OUTX\_L\_A\_OIS register**

D7	D6	D5	D4	D3	D2	D1	D0
----	----	----	----	----	----	----	----

**Table 256. IF2\_OUTX\_H\_A\_OIS register**

D15	D14	D13	D12	D11	D10	D9	D8
-----	-----	-----	-----	-----	-----	----	----

**Table 257. IF2\_OUTX\_H\_A\_OIS register description**

D[15:0]	Accelerometer OIS chain X-axis linear acceleration output value
---------	---

### 11.8 IF2\_OUTY\_L\_A\_OIS (2Ah) and IF2\_OUTY\_H\_A\_OIS (2Bh)

Linear acceleration sensor Y-axis output register (R). The value is expressed as a 16-bit word in two's complement.

Data are according to the accelerometer full-scale and ODR (7.68 kHz) settings of the OIS accelerometer.

**Table 258. IF2\_OUTY\_L\_A\_OIS register**

D7	D6	D5	D4	D3	D2	D1	D0
----	----	----	----	----	----	----	----

**Table 259. IF2\_OUTY\_H\_A\_OIS register**

D15	D14	D13	D12	D11	D10	D9	D8
-----	-----	-----	-----	-----	-----	----	----

**Table 260. IF2\_OUTY\_H\_A\_OIS register description**

D[15:0]	Accelerometer OIS chain Y-axis linear acceleration output value
---------	---

### 11.9 IF2\_OUTZ\_L\_A\_OIS (2Ch) and IF2\_OUTZ\_H\_A\_OIS (2Dh)

Linear acceleration sensor Z-axis output register (R). The value is expressed as a 16-bit word in two's complement.

Data are according to the accelerometer full-scale and ODR (7.68 kHz) settings of the OIS accelerometer.

**Table 261. IF2\_OUTZ\_L\_A\_OIS register**

D7	D6	D5	D4	D3	D2	D1	D0
----	----	----	----	----	----	----	----

**Table 262. IF2\_OUTZ\_H\_A\_OIS register**

D15	D14	D13	D12	D11	D10	D9	D8
-----	-----	-----	-----	-----	-----	----	----

**Table 263. IF2\_OUTZ\_H\_A\_OIS register description**

D[15:0]	Accelerometer OIS chain Z-axis linear acceleration output value
---------	---

### 11.10 IF2\_HANDSHAKE\_CTRL (6Eh)

Control register (IF2 side) for UI / IF2 shared registers (R/W)

**Table 264. IF2\_HANDSHAKE\_CTRL register**

0 <sup>(1)</sup>	0 <sup>(1)</sup>	0 <sup>(1)</sup>	0 <sup>(1)</sup>	0 <sup>(1)</sup>	0 <sup>(1)</sup>	IF2_SHARED_REQ	IF2_SHARED_ACK
------------------	------------------	------------------	------------------	------------------	------------------	----------------	----------------

1. This bit must be set to 0 for the correct operation of the device.

**Table 265. IF2\_HANDSHAKE\_CTRL register description**

IF2_SHARED_REQ	This bit is used by the auxiliary SPI (IF2) controller interface to request access to the UI_IF2_SHARED_0 (65h) through UI_IF2_SHARED_5 (6Ah) registers. When the R/W operation is finished, the controller must reset this bit.
IF2_SHARED_ACK	Auxiliary SPI (IF2) interface side. This bit acknowledges the handshake. If the primary interface is not accessing the shared registers, this bit is set to 1 by the device and the R/W operation on the UI_IF2_SHARED_0 (65h) through UI_IF2_SHARED_5 (6Ah) registers is allowed on the auxiliary SPI interface.

## 11.11 IF2\_INT\_OIS (6Fh)

OIS interrupt configuration register and self-test setting

The auxiliary interface can write this register when the OIS\_CTRL\_FROM\_UI bit in the FUNC\_CFG\_ACCESS (01h) register is equal to 0 (auxiliary IF full-control mode); this register is read-only when the OIS\_CTRL\_FROM\_UI bit is equal to 1 (primary IF full-control mode) and shows the content of the UI\_INT\_OIS (6Fh) register.

**Table 266. IF2\_INT\_OIS register**

INT2_DRDY_OIS	DRDY_MASK_OIS	0 <sup>(1)</sup>	ST_OIS_CLAMPDIS	ST_G_OIS_1	ST_G_OIS_0	ST_XL_OIS_1	ST_XL_OIS_0
---------------	---------------	------------------	-----------------	------------	------------	-------------	-------------

1. This bit must be set to 0 for the correct operation of the device.

**Table 267. IF2\_INT\_OIS register description**

INT2_DRDY_OIS	Enables OIS chain DRDY on INT2 pin. This setting has priority over all other INT2 settings.
DRDY_MASK_OIS	Enables / masks OIS data available. Default value: 0 (0: disabled; 1: masks OIS DRDY on pin (both accelerometer and gyroscope) until filter settling ends (accelerometer and gyroscope independently masked))
ST_OIS_CLAMPDIS	Disables OIS chain clamp during self-test. Default value: 0 (0: All OIS chain outputs = 8000h during self-test; 1: OIS chain self-test outputs)
ST_G_OIS_[1:0]	Gyroscope OIS chain self-test selection when the self-test is enabled and ST_OIS_CLAMPDIS = 0. (00: normal mode (default); 01: positive sign self-test; 10: normal mode; 11: negative sign self-test)
ST_XL_OIS_[1:0]	Accelerometer OIS chain self-test selection; activated only if the accelerometer OIS chain is enabled. (00: normal mode (default); 01: positive sign self-test; 10: negative sign self-test; 11: reserved)

## 11.12 IF2\_CTRL1\_OIS (70h)

OIS configuration register

The auxiliary interface can write this register when the OIS\_CTRL\_FROM\_UI bit in the FUNC\_CFG\_ACCESS (01h) register is equal to 0 (auxiliary IF full-control mode); this register is read-only when the OIS\_CTRL\_FROM\_UI bit is equal to 1 (primary IF full-control mode) and shows the content of the UI\_CTRL1\_OIS (70h) register.

**Table 268. IF2\_CTRL1\_OIS register**

0 <sup>(1)</sup>	0 <sup>(1)</sup>	SIM_OIS	0 <sup>(1)</sup>	0 <sup>(1)</sup>	OIS_XL_EN	OIS_G_EN	AUX_SPI_READ_EN
------------------	------------------	---------	------------------	------------------	-----------	----------	-----------------

1. This bit must be set to 0 for the correct operation of the device.

**Table 269. IF2\_CTRL1\_OIS register description**

SIM_OIS	Auxiliary SPI 3- or 4-wire interface. Default value: 0 (0: 4-wire auxiliary SPI; 1: 3-wire auxiliary SPI)
OIS_XL_EN	Enables accelerometer OIS chain. Default value: 0 (0: accelerometer OIS chain disabled; 1: accelerometer OIS chain enabled)
OIS_G_EN	Enables gyroscope OIS chain. Default value: 0 (0: gyroscope OIS chain disabled; 1: gyroscope OIS chain enabled)
AUX_SPI_READ_EN	Selection between auxiliary SPI or auxiliary I3C. Default value: 0 (0: OIS data read from auxiliary SPI disabled and I3C auxiliary enabled; 1: OIS data read from auxiliary SPI enabled and I3C auxiliary disabled)

### 11.13 IF2\_CTRL2\_OIS (71h)

OIS configuration register

The auxiliary interface can write this register when the OIS\_CTRL\_FROM\_UI bit in the FUNC\_CFG\_ACCESS (01h) register is equal to 0 (auxiliary IF full-control mode); this register is read-only when the OIS\_CTRL\_FROM\_UI bit is equal to 1 (primary IF full-control mode) and shows the content of the UI\_CTRL2\_OIS (71h) register.

**Table 270. IF2\_CTRL2\_OIS register**

0 <sup>(1)</sup>	0 <sup>(1)</sup>	0 <sup>(1)</sup>	LPF1_G_OIS_BW_1	LPF1_G_OIS_BW_0	FS_G_OIS_2	FS_G_OIS_1	FS_G_OIS_0
------------------	------------------	------------------	-----------------	-----------------	------------	------------	------------

1. This bit must be set to 0 for the correct operation of the device.

**Table 271. IF2\_CTRL2\_OIS register description**

LPF1_G_OIS_BW_[1:0]	Gyroscope OIS digital LPF1 filter bandwidth selection. Refer to Table 272.
FS_G_OIS_[2:0]	Gyroscope OIS full-scale selection: (000: reserved; 001: ±250 dps; 010: ±500 dps; 011: ±1000 dps; 100: ±2000 dps; 101: reserved; 110: reserved; 111: reserved)

**Table 272. Gyroscope OIS chain digital LPF1 filter bandwidth selection**

LPF1_G_OIS_BW_[1:0]	Cutoff [Hz]	Phase @ 20 Hz [°]
00	293 Hz	-7.1°
01	217 Hz	-9.1°
10	158 Hz	-11.9°
11	476 Hz	-5.1°

## 11.14 IF2\_CTRL3\_OIS (72h)

OIS configuration register

The auxiliary interface can write this register when the OIS\_CTRL\_FROM\_UI bit in the FUNC\_CFG\_ACCESS (01h) register is equal to 0 (auxiliary IF full-control mode); this register is read-only when the OIS\_CTRL\_FROM\_UI bit is equal to 1 (primary IF full-control mode) and shows the content of the UI\_CTRL3\_OIS (72h) register.

**Table 273. IF2\_CTRL3\_OIS register**

0 <sup>(1)</sup>	0 <sup>(1)</sup>	LPF_XL_OIS_BW_2	LPF_XL_OIS_BW_1	LPF_XL_OIS_BW_0	0 <sup>(1)</sup>	FS_XL_OIS_1	FS_XL_OIS_0
------------------	------------------	-----------------	-----------------	-----------------	------------------	-------------	-------------

1. This bit must be set to 0 for the correct operation of the device.

**Table 274. IF2\_CTRL3\_OIS register description**

LPF_XL_OIS_BW_[2:0]	Selects accelerometer OIS channel bandwidth, see Table 275. Default value: 0
FS_XL_OIS_[1:0]	Selects accelerometer OIS channel full-scale: (00: ±2 g (default); 01: ±4 g; 10: ±8 g; 11: ±16 g)

*Note:* When the accelerometer full-scale value is selected only from the UI side, it is readable also from the OIS side.

**Table 275. Accelerometer OIS channel bandwidth and phase**

LPF_XL_OIS_BW_[2:0]	Typ. overall bandwidth [Hz]	Typ. overall phase [°]
000	749 Hz	-3.41 deg @ 20 Hz
001	539 Hz	-4.04 deg @ 20 Hz
010	342 Hz	-5.31 deg @ 20 Hz
011	162 Hz	-9.08 deg @ 20 Hz
100	78.5 Hz	-16.4 deg @ 20 Hz
101	38.6 Hz	-29.6 deg @ 20 Hz
110	19.3 Hz	-28.8 deg @ 10 Hz
111	9.8 Hz	-29.1 deg @ 5 Hz

## 12 Embedded functions register mapping

The table given below provides a list of the registers for the embedded functions available in the device and the corresponding addresses. Embedded functions registers are accessible when EMB\_FUNC\_REG\_ACCESS is set to 1 in FUNC\_CFG\_ACCESS (01h).

**Table 276. Register address map - embedded functions**

Name	Type	Register address		Default	Comment
		Hex	Binary		
PAGE_SEL	R/W	02	00000010	00000001	
EMB_FUNC_EN_A	R/W	04	00000100	00000000	
EMB_FUNC_EN_B	R/W	05	00000101	00000000	
EMB_FUNC_EXEC_STATUS	R	07	00000111	output	
PAGE_ADDRESS	R/W	08	00001000	00000000	
PAGE_VALUE	R/W	09	00001001	00000000	
EMB_FUNC_INT1	R/W	0A	00001010	00000000	
FSM_INT1	R/W	0B	00001011	00000000	
RESERVED	-	0C			
MLC_INT1	R/W	0D	00001101	00000000	
EMB_FUNC_INT2	R/W	0E	00001110	00000000	
FSM_INT2	R/W	0F	00001111	00000000	
RESERVED	-	10			
MLC_INT2	R/W	11	00010001	00000000	
EMB_FUNC_STATUS	R	12	00010010	output	
FSM_STATUS	R	13	00010011	output	
RESERVED	-	14			
MLC_STATUS	R	15	00010101	output	
PAGE_RW	R/W	17	00010111	00000000	
SFLP_GBIASX_L	R	18	00011000	output	
SFLP_GBIASX_H	R	19	00011001	output	
SFLP_GBIASY_L	R	1A	00011010	output	
SFLP_GBIASY_H	R	1B	00011011	output	
SFLP_GBIASZ_L	R	1C	00011100	output	
SFLP_GBIASZ_H	R	1D	00011101	output	
SFLP_GRAVX_L	R	1E	00011110	output	
SFLP_GRAVX_H	R	1F	00011111	output	
SFLP_GRAVY_L	R	20	00100000	output	
SFLP_GRAVY_H	R	21	00100001	output	
SFLP_GRAVZ_L	R	22	00100010	output	
SFLP_GRAVZ_H	R	23	00100011	output	
SFLP_QUATW_L	R	2A	00101010	output	
SFLP_QUATW_H	R	2B	00101011	output	
SFLP_QUATX_L	R	2C	00101100	output	

Name	Type	Register address		Default	Comment
		Hex	Binary		
SFLP_QUATX_H	R	2D	00101101	output	
SFLP_QUATY_L	R	2E	00101110	output	
SFLP_QUATY_H	R	2F	00101111	output	
SFLP_QUATZ_L	R	30	00110000	output	
SFLP_QUATZ_H	R	31	00110001	output	
SFLP_GBIASX_INIT_L	R/W	32	00110010	00000000	
SFLP_GBIASX_INIT_H	R/W	33	00110011	00000000	
SFLP_GBIASY_INIT_L	R/W	34	00110100	00000000	
SFLP_GBIASY_INIT_H	R/W	35	00110101	00000000	
SFLP_GBIASZ_INIT_L	R/W	36	00110110	00000000	
SFLP_GBIASZ_INIT_H	R/W	37	00110111	00000000	
RESERVED	-	38-43			
EMB_FUNC_FIFO_EN_A	R/W	44	01000100	00000000	
EMB_FUNC_FIFO_EN_B	R/W	45	01000101		
FSM_ENABLE	R/W	46	01000110	00000000	
RESERVED	-	47			
FSM_LONG_COUNTER_L	R/W	48	01001000	00000000	
FSM_LONG_COUNTER_H	R/W	49	01001001	00000000	
RESERVED	-	4A			
INT_ACK_MASK	R/W	4B	01001011	00000000	
FSM_OUTS1	R	4C	01001100	output	
FSM_OUTS2	R	4D	01001101	output	
FSM_OUTS3	R	4E	01001110	output	
FSM_OUTS4	R	4F	01001111	output	
FSM_OUTS5	R	50	01010000	output	
FSM_OUTS6	R	51	01010001	output	
FSM_OUTS7	R	52	01010010	output	
FSM_OUTS8	R	53	01010011	output	
RESERVED	-	54- 5D			
SFLP_ODR	R/W	5E	01011110	01011011	
FSM_ODR	R/W	5F	01011111	01001011	
MLC_ODR	R/W	60	01100000	00010101	
STEP_COUNTER_L	R	62	01100010	output	
STEP_COUNTER_H	R	63	01100011	output	
EMB_FUNC_SRC	R/W	64	01100100	output	
EMB_FUNC_INIT_A	R/W	66	01100110	00000000	
EMB_FUNC_INIT_B	R/W	67	01100111	00000000	
EMB_FUNC_SENSOR_CONV_EN	R/W	6E	01101110	00001111	
MLC1_SRC	R	70	01110000	output	
MLC2_SRC	R	71	01110001	output	

Name	Type	Register address		Default	Comment
		Hex	Binary		
MLC3_SRC	R	72	01110010	output	
MLC4_SRC	R	73	01110011	output	
MLC5_SRC	R	74	01110100	output	
MLC6_SRC	R	75	01110101	output	
MLC7_SRC	R	76	01110110	output	
MLC8_SRC	R	77	01110111	output	

Reserved registers must not be changed. Writing to those registers may cause permanent damage to the device. The content of the registers that are loaded at boot should not be changed. They contain the factory calibration values. Their content is automatically restored when the device is powered up.

## 13 Embedded functions register description

### 13.1 PAGE\_SEL (02h)

Enable advanced features dedicated page (R/W)

Table 277. PAGE\_SEL register

PAGE_SEL3	PAGE_SEL2	PAGE_SEL1	PAGE_SEL0	0 <sup>(1)</sup>	0 <sup>(1)</sup>	0 <sup>(1)</sup>	1 <sup>(2)</sup>
-----------	-----------	-----------	-----------	------------------	------------------	------------------	------------------

1. This bit must be set to 0 for the correct operation of the device.

2. This bit must be set to 1 for the correct operation of the device.

Table 278. PAGE\_SEL register description

PAGE_SEL[3:0]	Selects the advanced features dedicated page. Default value: 0000
---------------	---

### 13.2 EMB\_FUNC\_EN\_A (04h)

Enable embedded functions register (R/W)

Table 279. EMB\_FUNC\_EN\_A register

MLC_BEFORE_FSM_EN	0 <sup>(1)</sup>	SIGN_MOTION_EN	TILT_EN	PEDO_EN	0 <sup>(1)</sup>	SFLP_GAME_EN	0 <sup>(1)</sup>
-------------------	------------------	----------------	---------	---------	------------------	--------------	------------------

1. This bit must be set to 0 for the correct operation of the device.

Table 280. EMB\_FUNC\_EN\_A register description

MLC_BEFORE_FSM_EN <sup>(1)</sup>	Enables machine learning core function. When the machine learning core is enabled by setting this bit to 1, the MLC algorithms are executed before the FSM programs. Default value: 0 (0: machine learning core function disabled; 1: machine learning core function enabled and executed before FSM programs)
SIGN_MOTION_EN	Enables significant motion detection function. Default value: 0 (0: significant motion detection function disabled; 1: significant motion detection function enabled)
TILT_EN	Enables tilt calculation. Default value: 0 (0: tilt algorithm disabled; 1: tilt algorithm enabled)
PEDO_EN	Enables pedometer algorithm. Default value: 0 (0: pedometer algorithm disabled; 1: pedometer algorithm enabled)
SFLP_GAME_EN	Enables sensor fusion low-power algorithm for 6-axis (accelerometer + gyroscope) game rotation vector. Default value: 0 (0: sensor fusion algorithm for 6-axis accelerometer + gyroscope disabled; 1: sensor fusion algorithm for 6-axis accelerometer + gyroscope enabled)

1. MLC\_EN bit in the EMB\_FUNC\_EN\_B (05h) register must be set to 0 when using this bit.

### 13.3 EMB\_FUNC\_EN\_B (05h)

Enable embedded functions register (R/W)

**Table 281. EMB\_FUNC\_EN\_B register**

0 <sup>(1)</sup>	0 <sup>(1)</sup>	0 <sup>(1)</sup>	MLC_EN	FIFO_COMPR_EN	0 <sup>(1)</sup>	0 <sup>(1)</sup>	FSM_EN
------------------	------------------	------------------	--------	---------------	------------------	------------------	--------

1. This bit must be set to 0 for the correct operation of the device.

**Table 282. EMB\_FUNC\_EN\_B register description**

MLC_EN <sup>(1)</sup>	Enables machine learning core function. When the machine learning core is enabled by setting this bit to 1, the MLC algorithms are executed after executing the FSM programs. Default value: 0 (0: machine learning core function disabled; 1: machine learning core function enabled and executed after FSM programs)
FIFO_COMPR_EN <sup>(2)</sup>	Enables FIFO compression function. Default value: 0 (0: FIFO compression function disabled; 1: FIFO compression function enabled)
FSM_EN	Enables finite state machine (FSM) function. Default value: 0 (0: FSM function disabled; 1: FSM function enabled)

1. MLC\_BEFORE\_FSM\_EN bit in the EMB\_FUNC\_EN\_A (04h) register must be set to 0 when using this bit.

2. This bit is activated if the FIFO\_COMPR\_RT\_EN bit of FIFO\_CTRL2 (08h) is set to 1.

### 13.4 EMB\_FUNC\_EXEC\_STATUS (07h)

Embedded functions execution status register (R)

**Table 283. EMB\_FUNC\_EXEC\_STATUS register**

0	0	0	0	0	0	EMB_FUNC_EXEC_OVR	EMB_FUNC_ENDOP
---	---	---	---	---	---	-------------------	----------------

**Table 284. EMB\_FUNC\_EXEC\_STATUS register description**

EMB_FUNC_EXEC_OVR	This bit is set to 1 when the execution of the embedded functions program exceeds maximum time (new data are generated before the end of the algorithms). Default value: 0
EMB_FUNC_ENDOP	When this bit is set to 1, no embedded function is running. Default value: 0

### 13.5 PAGE\_ADDRESS (08h)

Page address register (R/W)

**Table 285. PAGE\_ADDRESS register**

PAGE_ADDR7	PAGE_ADDR6	PAGE_ADDR5	PAGE_ADDR4	PAGE_ADDR3	PAGE_ADDR2	PAGE_ADDR1	PAGE_ADDR0
------------	------------	------------	------------	------------	------------	------------	------------

**Table 286. PAGE\_ADDRESS register description**

PAGE_ADDR[7:0]	After setting the bit PAGE_WRITE / PAGE_READ in register <a href="#">PAGE_RW (17h)</a> , this register is used to set the address of the register to be written/read in the advanced features page selected through the bits PAGE_SEL[3:0] in register <a href="#">PAGE_SEL (02h)</a> .
----------------	---

### 13.6 PAGE\_VALUE (09h)

Page value register (R/W)

**Table 287. PAGE\_VALUE register**

PAGE_VALUE7	PAGE_VALUE6	PAGE_VALUE5	PAGE_VALUE4	PAGE_VALUE3	PAGE_VALUE2	PAGE_VALUE1	PAGE_VALUE0
-------------	-------------	-------------	-------------	-------------	-------------	-------------	-------------

**Table 288. PAGE\_VALUE register description**

PAGE_VALUE[7:0]	These bits are used to write (if the bit PAGE_WRITE = 1 in register <a href="#">PAGE_RW (17h)</a> ) or read (if the bit PAGE_READ = 1 in register <a href="#">PAGE_RW (17h)</a> ) the data at the address PAGE_ADDR[7:0] of the selected advanced features page.
-----------------	--

### 13.7 EMB\_FUNC\_INT1 (0Ah)

INT1 pin control register (R/W)

Each bit in this register enables a signal to be carried over INT1. The pin's output supplies the OR combination of the selected signals.

**Table 289. EMB\_FUNC\_INT1 register**

INT1_FSM_LC	0 <sup>(1)</sup>	INT1_SIG_MOT	INT1_TILT	INT1_STEP_DETECTOR	0 <sup>(1)</sup>	0 <sup>(1)</sup>	0 <sup>(1)</sup>
-------------	------------------	--------------	-----------	--------------------	------------------	------------------	------------------

1. This bit must be set to 0 for the correct operation of the device.

**Table 290. EMB\_FUNC\_INT1 register description**

INT1_FSM_LC <sup>(1)</sup>	Routing FSM long counter timeout interrupt event to INT1. Default value: 0 (0: routing to INT1 disabled; 1: routing to INT1 enabled)
INT1_SIG_MOT <sup>(1)</sup>	Routing significant motion event to INT1. Default value: 0 (0: routing to INT1 disabled; 1: routing to INT1 enabled)
INT1_TILT <sup>(1)</sup>	Routing tilt event to INT1. Default value: 0 (0: routing to INT1 disabled; 1: routing to INT1 enabled)
INT1_STEP_DETECTOR <sup>(1)</sup>	Routing pedometer step recognition event to INT1. Default value: 0 (0: routing to INT1 disabled; 1: routing to INT1 enabled)

1. This bit is activated if the INT1\_EMB\_FUNC bit of [MD1\\_CFG \(5Eh\)](#) is set to 1.

## 13.8 FSM\_INT1 (0Bh)

INT1 pin control register (R/W)

Each bit in this register enables a signal to be carried over INT1. The pin's output supplies the OR combination of the selected signals.

**Table 291. FSM\_INT1 register**

INT1_FSM8	INT1_FSM7	INT1_FSM6	INT1_FSM5	INT1_FSM4	INT1_FSM3	INT1_FSM2	INT1_FSM1
-----------	-----------	-----------	-----------	-----------	-----------	-----------	-----------

**Table 292. FSM\_INT1 register description**

INT1_FSM8 <sup>(1)</sup>	Routing FSM8 interrupt event to INT1. Default value: 0 (0: routing to INT1 disabled; 1: routing to INT1 enabled)
INT1_FSM7 <sup>(1)</sup>	Routing FSM7 interrupt event to INT1. Default value: 0 (0: routing to INT1 disabled; 1: routing to INT1 enabled)
INT1_FSM6 <sup>(1)</sup>	Routing FSM6 interrupt event to INT1. Default value: 0 (0: routing to INT1 disabled; 1: routing to INT1 enabled)
INT1_FSM5 <sup>(1)</sup>	Routing FSM5 interrupt event to INT1. Default value: 0 (0: routing to INT1 disabled; 1: routing to INT1 enabled)
INT1_FSM4 <sup>(1)</sup>	Routing FSM4 interrupt event to INT1. Default value: 0 (0: routing to INT1 disabled; 1: routing to INT1 enabled)
INT1_FSM3 <sup>(1)</sup>	Routing FSM3 interrupt event to INT1. Default value: 0 (0: routing to INT1 disabled; 1: routing to INT1 enabled)
INT1_FSM2 <sup>(1)</sup>	Routing FSM2 interrupt event to INT1. Default value: 0 (0: routing to INT1 disabled; 1: routing to INT1 enabled)
INT1_FSM1 <sup>(1)</sup>	Routing FSM1 interrupt event to INT1. Default value: 0 (0: routing to INT1 disabled; 1: routing to INT1 enabled)

1. This bit is activated if the INT1\_EMB\_FUNC bit of MD1\_CFG (5Eh) is set to 1.

### 13.9 MLC\_INT1 (0Dh)

INT1 pin control register (R/W)

Each bit in this register enables a signal to be carried over INT1. The pin's output supplies the OR combination of the selected signals.

**Table 293. MLC\_INT1 register**

INT1_MLC8	INT1_MLC7	INT1_MLC6	INT1_MLC5	INT1_MLC4	INT1_MLC3	INT1_MLC2	INT1_MLC1
-----------	-----------	-----------	-----------	-----------	-----------	-----------	-----------

**Table 294. MLC\_INT1 register description**

INT1_MLC8	Routing MLC8 interrupt event to INT1. Default value: 0 (0: routing to INT1 disabled; 1: routing to INT1 enabled)
INT1_MLC7	Routing MLC7 interrupt event to INT1. Default value: 0 (0: routing to INT1 disabled; 1: routing to INT1 enabled)
INT1_MLC6	Routing MLC6 interrupt event to INT1. Default value: 0 (0: routing to INT1 disabled; 1: routing to INT1 enabled)
INT1_MLC5	Routing MLC5 interrupt event to INT1. Default value: 0 (0: routing to INT1 disabled; 1: routing to INT1 enabled)
INT1_MLC4	Routing MLC4 interrupt event to INT1. Default value: 0 (0: routing to INT1 disabled; 1: routing to INT1 enabled)
INT1_MLC3	Routing MLC3 interrupt event to INT1. Default value: 0 (0: routing to INT1 disabled; 1: routing to INT1 enabled)
INT1_MLC2	Routing MLC2 interrupt event to INT1. Default value: 0 (0: routing to INT1 disabled; 1: routing to INT1 enabled)
INT1_MLC1	Routing MLC1 interrupt event to INT1. Default value: 0 (0: routing to INT1 disabled; 1: routing to INT1 enabled)

### 13.10 EMB\_FUNC\_INT2 (0Eh)

INT2 pin control register (R/W)

Each bit in this register enables a signal to be carried over INT2. The pin's output supplies the OR combination of the selected signals.

**Table 295. EMB\_FUNC\_INT2 register**

INT2_FSM_LC	0 <sup>(1)</sup>	INT2_SIG_MOT	INT2_TILT	INT2_STEP_DETECTOR	0 <sup>(1)</sup>	0 <sup>(1)</sup>	0 <sup>(1)</sup>
-------------	------------------	--------------	-----------	--------------------	------------------	------------------	------------------

1. This bit must be set to 0 for the correct operation of the device.

**Table 296. EMB\_FUNC\_INT2 register description**

INT2_FSM_LC <sup>(1)</sup>	Routing FSM long counter timeout interrupt event to INT2. Default value: 0 (0: routing to INT2 disabled; 1: routing to INT2 enabled)
INT2_SIG_MOT <sup>(1)</sup>	Routing significant motion event to INT2. Default value: 0 (0: routing to INT2 disabled; 1: routing to INT2 enabled)
INT2_TILT <sup>(1)</sup>	Routing tilt event to INT2. Default value: 0 (0: routing to INT2 disabled; 1: routing to INT2 enabled)
INT2_STEP_DETECTOR <sup>(1)</sup>	Routing pedometer step recognition event to INT2. Default value: 0 (0: routing to INT2 disabled; 1: routing to INT2 enabled)

1. This bit is activated if the INT2\_EMB\_FUNC bit of MD2\_CFG (5Fh) is set to 1.

### 13.11 FSM\_INT2 (0Fh)

INT2 pin control register (R/W)

Each bit in this register enables a signal to be carried over INT2. The pin's output supplies the OR combination of the selected signals.

**Table 297. FSM\_INT2 register**

INT2_FSM8	INT2_FSM7	INT2_FSM6	INT2_FSM5	INT2_FSM4	INT2_FSM3	INT2_FSM2	INT2_FSM1
-----------	-----------	-----------	-----------	-----------	-----------	-----------	-----------

**Table 298. FSM\_INT2 register description**

INT2_FSM8 <sup>(1)</sup>	Routing FSM8 interrupt event to INT2. Default value: 0 (0: routing to INT2 disabled; 1: routing to INT2 enabled)
INT2_FSM7 <sup>(1)</sup>	Routing FSM7 interrupt event to INT2. Default value: 0 (0: routing to INT2 disabled; 1: routing to INT2 enabled)
INT2_FSM6 <sup>(1)</sup>	Routing FSM6 interrupt event to INT2. Default value: 0 (0: routing to INT2 disabled; 1: routing to INT2 enabled)
INT2_FSM5 <sup>(1)</sup>	Routing FSM5 interrupt event to INT2. Default value: 0 (0: routing to INT2 disabled; 1: routing to INT2 enabled)
INT2_FSM4 <sup>(1)</sup>	Routing FSM4 interrupt event to INT2. Default value: 0 (0: routing to INT2 disabled; 1: routing to INT2 enabled)
INT2_FSM3 <sup>(1)</sup>	Routing FSM3 interrupt event to INT2. Default value: 0 (0: routing to INT2 disabled; 1: routing to INT2 enabled)
INT2_FSM2 <sup>(1)</sup>	Routing FSM2 interrupt event to INT2. Default value: 0 (0: routing to INT2 disabled; 1: routing to INT2 enabled)
INT2_FSM1 <sup>(1)</sup>	Routing FSM1 interrupt event to INT2. Default value: 0 (0: routing to INT2 disabled; 1: routing to INT2 enabled)

1. This bit is activated if the INT2\_EMB\_FUNC bit of MD2\_CFG (5Fh) is set to 1.

### 13.12 MLC\_INT2 (11h)

INT2 pin control register (R/W)

Each bit in this register enables a signal to be carried over INT2. The pin's output supplies the OR combination of the selected signals.

**Table 299. MLC\_INT2 register**

INT2_MLC8	INT2_MLC7	INT2_MLC6	INT2_MLC5	INT2_MLC4	INT2_MLC3	INT2_MLC2	INT2_MLC1
-----------	-----------	-----------	-----------	-----------	-----------	-----------	-----------

**Table 300. MLC\_INT2 register description**

INT2_MLC8	Routing MLC8 interrupt event to INT2. Default value: 0 (0: routing to INT2 disabled; 1: routing to INT2 enabled)
INT2_MLC7	Routing MLC7 interrupt event to INT2. Default value: 0 (0: routing to INT2 disabled; 1: routing to INT2 enabled)
INT2_MLC6	Routing MLC6 interrupt event to INT2. Default value: 0 (0: routing to INT2 disabled; 1: routing to INT2 enabled)
INT2_MLC5	Routing MLC5 interrupt event to INT2. Default value: 0 (0: routing to INT2 disabled; 1: routing to INT2 enabled)
INT2_MLC4	Routing MLC4 interrupt event to INT2. Default value: 0 (0: routing to INT2 disabled; 1: routing to INT2 enabled)
INT2_MLC3	Routing MLC3 interrupt event to INT2. Default value: 0 (0: routing to INT2 disabled; 1: routing to INT2 enabled)
INT2_MLC2	Routing MLC2 interrupt event to INT2. Default value: 0 (0: routing to INT2 disabled; 1: routing to INT2 enabled)
INT2_MLC1	Routing MLC1 interrupt event to INT2. Default value: 0 (0: routing to INT2 disabled; 1: routing to INT2 enabled)

### 13.13 EMB\_FUNC\_STATUS (12h)

Embedded function status register (R)

**Table 301. EMB\_FUNC\_STATUS register**

IS_FSM_LC	0	IS_SIGMOT	IS_TILT	IS_STEP_DET	0	0	0
-----------	---	-----------	---------	-------------	---	---	---

**Table 302. EMB\_FUNC\_STATUS register description**

IS_FSM_LC	Interrupt status bit for FSM long counter timeout interrupt event. (1: interrupt detected; 0: no interrupt)
IS_SIGMOT	Interrupt status bit for significant motion detection (1: interrupt detected; 0: no interrupt)
IS_TILT	Interrupt status bit for tilt detection (1: interrupt detected; 0: no interrupt)
IS_STEP_DET	Interrupt status bit for step detection (1: interrupt detected; 0: no interrupt)

### 13.14 FSM\_STATUS (13h)

Finite state machine status register (R)

**Table 303. FSM\_STATUS register**

IS_FSM8	IS_FSM7	IS_FSM6	IS_FSM5	IS_FSM4	IS_FSM3	IS_FSM2	IS_FSM1
---------	---------	---------	---------	---------	---------	---------	---------

**Table 304. FSM\_STATUS register description**

IS_FSM8	Interrupt status bit for FSM8 interrupt event. (1: interrupt detected; 0: no interrupt)
IS_FSM7	Interrupt status bit for FSM7 interrupt event. (1: interrupt detected; 0: no interrupt)
IS_FSM6	Interrupt status bit for FSM6 interrupt event. (1: interrupt detected; 0: no interrupt)
IS_FSM5	Interrupt status bit for FSM5 interrupt event. (1: interrupt detected; 0: no interrupt)
IS_FSM4	Interrupt status bit for FSM4 interrupt event. (1: interrupt detected; 0: no interrupt)
IS_FSM3	Interrupt status bit for FSM3 interrupt event. (1: interrupt detected; 0: no interrupt)
IS_FSM2	Interrupt status bit for FSM2 interrupt event. (1: interrupt detected; 0: no interrupt)
IS_FSM1	Interrupt status bit for FSM1 interrupt event. (1: interrupt detected; 0: no interrupt)

### 13.15 MLC\_STATUS (15h)

Machine learning core status register (R)

**Table 305. MLC\_STATUS register**

IS_MLC8	IS_MLC7	IS_MLC6	IS_MLC5	IS_MLC4	IS_MLC3	IS_MLC2	IS_MLC1
---------	---------	---------	---------	---------	---------	---------	---------

**Table 306. MLC\_STATUS register description**

IS_MLC8	Interrupt status bit for MLC8 interrupt event. (1: interrupt detected; 0: no interrupt)
IS_MLC7	Interrupt status bit for MLC7 interrupt event. (1: interrupt detected; 0: no interrupt)
IS_MLC6	Interrupt status bit for MLC6 interrupt event. (1: interrupt detected; 0: no interrupt)
IS_MLC5	Interrupt status bit for MLC5 interrupt event. (1: interrupt detected; 0: no interrupt)
IS_MLC4	Interrupt status bit for MLC4 interrupt event. (1: interrupt detected; 0: no interrupt)
IS_MLC3	Interrupt status bit for MLC3 interrupt event. (1: interrupt detected; 0: no interrupt)
IS_MLC2	Interrupt status bit for MLC2 interrupt event. (1: interrupt detected; 0: no interrupt)
IS_MLC1	Interrupt status bit for MLC1 interrupt event. (1: interrupt detected; 0: no interrupt)

### 13.16 PAGE\_RW (17h)

Enable read and write mode of advanced features dedicated page (R/W)

**Table 307. PAGE\_RW register**

EMB_FUNC_LIR	PAGE_WRITE	PAGE_READ	0 <sup>(1)</sup>	0 <sup>(1)</sup>	0 <sup>(1)</sup>	0 <sup>(1)</sup>	0 <sup>(1)</sup>
--------------	------------	-----------	------------------	------------------	------------------	------------------	------------------

1. This bit must be set to 0 for the correct operation of the device.

**Table 308. PAGE\_RW register description**

EMB_FUNC_LIR	Latched interrupt mode for embedded functions. Default value: 0 (0: embedded functions interrupt request not latched; 1: embedded functions interrupt request latched)
PAGE_WRITE	Enables writes to the selected advanced features dedicated page. <sup>(1)</sup> Default value: 0 (1: enable; 0: disable)
PAGE_READ	Enables reads from the selected advanced features dedicated page. <sup>(1)</sup> Default value: 0 (1: enable; 0: disable)

1. Page selected by PAGE\_SEL[3:0] in PAGE\_SEL (02h) register.

### 13.17 SFLP\_GBIASX\_L (18h) and SFLP\_GBIASX\_H (19h)

SFLP gyroscope bias X-axis output register (R). The value is expressed as a 16-bit word in two's complement with 4.375 mdps/LSB sensitivity.

**Table 309. SFLP\_GBIASX\_H and SFLP\_GBIASX\_L registers**

D15	D14	D13	D12	D11	D10	D9	D8
D7	D6	D5	D4	D3	D2	D1	D0

**Table 310. SFLP\_GBIASX\_H and SFLP\_GBIASX\_L register description**

D[15:0]	SFLP gyroscope bias X-axis output value
---------	---

### 13.18 SFLP\_GBIASY\_L (1Ah) and SFLP\_GBIASY\_H (1Bh)

SFLP gyroscope bias Y-axis output register (R). The value is expressed as a 16-bit word in two's complement with 4.375 mdps/LSB sensitivity.

**Table 311. SFLP\_GBIASY\_H and SFLP\_GBIASY\_L registers**

D15	D14	D13	D12	D11	D10	D9	D8
D7	D6	D5	D4	D3	D2	D1	D0

**Table 312. SFLP\_GBIASY\_H and SFLP\_GBIASY\_L register description**

D[15:0]	SFLP gyroscope bias Y-axis output value
---------	---

### 13.19 SFLP\_GBIASZ\_L (1Ch) and SFLP\_GBIASZ\_H (1Dh)

SFLP gyroscope bias Z-axis output register (R). The value is expressed as a 16-bit word in two's complement with 4.375 mdps/LSB sensitivity.

**Table 313. SFLP\_GBIASZ\_H and SFLP\_GBIASZ\_L registers**

D15	D14	D13	D12	D11	D10	D9	D8
D7	D6	D5	D4	D3	D2	D1	D0

**Table 314. SFLP\_GBIASZ\_H and SFLP\_GBIASZ\_L register description**

D[15:0]	SFLP gyroscope bias Z-axis output value
---------	---

### 13.20 SFLP\_GRAVX\_L (1Eh) and SFLP\_GRAVX\_H (1Fh)

SFLP gravity X-axis output register (R). The value is expressed as a 16-bit word in two's complement with 0.061 mg/LSB sensitivity.

**Table 315. SFLP\_GRAVX\_H and SFLP\_GRAVX\_L registers**

D15	D14	D13	D12	D11	D10	D9	D8
D7	D6	D5	D4	D3	D2	D1	D0

**Table 316. SFLP\_GRAVX\_H and SFLP\_GRAVX\_L register description**

D[15:0]	SFLP gravity X-axis output value
---------	----------------------------------

### 13.21 SFLP\_GRAVY\_L (20h) and SFLP\_GRAVY\_H (21h)

SFLP gravity Y-axis output register (R). The value is expressed as a 16-bit word in two's complement with 0.061 mg/LSB sensitivity.

**Table 317. SFLP\_GRAVY\_H and SFLP\_GRAVY\_L registers**

D15	D14	D13	D12	D11	D10	D9	D8
D7	D6	D5	D4	D3	D2	D1	D0

**Table 318. SFLP\_GRAVY\_H and SFLP\_GRAVY\_L register description**

D[15:0]	SFLP gravity Y-axis output value
---------	----------------------------------

### 13.22 SFLP\_GRAVZ\_L (22h) and SFLP\_GRAVZ\_H (23h)

SFLP gravity Z-axis output register (R). The value is expressed as a 16-bit word in two's complement with 0.061 mg/LSB sensitivity.

**Table 319. SFLP\_GRAVZ\_H and SFLP\_GRAVZ\_L registers**

D15	D14	D13	D12	D11	D10	D9	D8
D7	D6	D5	D4	D3	D2	D1	D0

**Table 320. SFLP\_GRAVZ\_H and SFLP\_GRAVZ\_L register description**

D[15:0]	SFLP gravity Z-axis output value
---------	----------------------------------

### 13.23 SFLP\_QUATW\_L (2Ah) and SFLP\_QUATW\_H (2Bh)

SFLP game rotation vector W value output register (R). The value is expressed as half-precision floating-point format: SEEEEEEEEEEEEEE (S: 1 sign bit; E: 5 exponent bits; F: 10 fraction bits).

**Table 321. SFLP\_QUATW\_H and SFLP\_QUATW\_L registers**

D15	D14	D13	D12	D11	D10	D9	D8
D7	D6	D5	D4	D3	D2	D1	D0

**Table 322. SFLP\_QUATW\_H and SFLP\_QUATW\_L register description**

D[15:0]	SFLP game rotation vector W value output value
---------	--

### 13.24 SFLP\_QUATX\_L (2Ch) and SFLP\_QUATX\_H (2Dh)

SFLP game rotation vector X value output register (R). The value is expressed as half-precision floating-point format: SEEEEEEEEEEEEEE (S: 1 sign bit; E: 5 exponent bits; F: 10 fraction bits).

**Table 323. SFLP\_QUATX\_H and SFLP\_QUATX\_L registers**

D15	D14	D13	D12	D11	D10	D9	D8
D7	D6	D5	D4	D3	D2	D1	D0

**Table 324. SFLP\_QUATX\_H and SFLP\_QUATX\_L register description**

D[15:0]	SFLP game rotation vector X value output value
---------	--

### 13.25 SFLP\_QUATY\_L (2Eh) and SFLP\_QUATY\_H (2Fh)

SFLP game rotation vector Y value output register (R). The value is expressed as half-precision floating-point format: SEEEEEEEEEEEEEE (S: 1 sign bit; E: 5 exponent bits; F: 10 fraction bits).

**Table 325. SFLP\_QUATY\_H and SFLP\_QUATY\_L registers**

D15	D14	D13	D12	D11	D10	D9	D8
D7	D6	D5	D4	D3	D2	D1	D0

**Table 326. SFLP\_QUATY\_H and SFLP\_QUATY\_L register description**

D[15:0]	SFLP game rotation vector Y value output value
---------	--

### 13.26 SFLP\_QUATZ\_L (30h) and SFLP\_QUATZ\_H (31h)

SFLP game rotation vector Z value output register (R). The value is expressed as half-precision floating-point format: SEEEEEEEEEEEEEE (S: 1 sign bit; E: 5 exponent bits; F: 10 fraction bits).

**Table 327. SFLP\_QUATZ\_H and SFLP\_QUATZ\_L registers**

D15	D14	D13	D12	D11	D10	D9	D8
D7	D6	D5	D4	D3	D2	D1	D0

**Table 328. SFLP\_QUATZ\_H and SFLP\_QUATZ\_L register description**

D[15:0]	SFLP game rotation vector Z value output value
---------	--

### 13.27 SFLP\_GBIASX\_INIT\_L (32h) and SFLP\_GBIASX\_INIT\_H (33h)

SFLP gyroscope bias X-axis initialization register (R/W). The value is expressed as half-precision floating-point format: SEEEEEEEEEEEEEE (S: 1 sign bit; E: 5 exponent bits; F: 10 fraction bits).

**Table 329. SFLP\_GBIASX\_INIT\_H and SFLP\_GBIASX\_INIT\_L registers**

D15	D14	D13	D12	D11	D10	D9	D8
D7	D6	D5	D4	D3	D2	D1	D0

**Table 330. SFLP\_GBIASX\_INIT\_H and SFLP\_GBIASX\_INIT\_L register description**

D[15:0]	SFLP gyroscope bias X-axis initial value
---------	--

### 13.28 SFLP\_GBIASY\_INIT\_L (34h) and SFLP\_GBIASY\_INIT\_H (35h)

SFLP gyroscope bias Y-axis initialization register (R/W). The value is expressed as half-precision floating-point format: SEEEEEEEEEEEEEE (S: 1 sign bit; E: 5 exponent bits; F: 10 fraction bits).

**Table 331. SFLP\_GBIASY\_INIT\_H and SFLP\_GBIASY\_INIT\_L registers**

D15	D14	D13	D12	D11	D10	D9	D8
D7	D6	D5	D4	D3	D2	D1	D0

**Table 332. SFLP\_GBIASY\_INIT\_H and SFLP\_GBIASY\_INIT\_L register description**

D[15:0]	SFLP gyroscope bias Y-axis initial value
---------	--

### 13.29 SFLP\_GBIASZ\_INIT\_L (36h) and SFLP\_GBIASZ\_INIT\_H (37h)

SFLP gyroscope bias Z-axis initialization register (R/W). The value is expressed as half-precision floating-point format: SEESEEEEEEEEEEE (S: 1 sign bit; E: 5 exponent bits; F: 10 fraction bits).

**Table 333. SFLP\_GBIASZ\_INIT\_H and SFLP\_GBIASZ\_INIT\_L registers**

D15	D14	D13	D12	D11	D10	D9	D8
D7	D6	D5	D4	D3	D2	D1	D0

**Table 334. SFLP\_GBIASZ\_INIT\_H and SFLP\_GBIASZ\_INIT\_L register description**

D[15:0]	SFLP gyroscope bias Z-axis initial value
---------	--

### 13.30 EMB\_FUNC\_FIFO\_EN\_A (44h)

Embedded functions FIFO configuration register A (R/W)

**Table 335. EMB\_FUNC\_FIFO\_EN\_A register**

MLC_FIFO_EN	STEP_COUNTER_FIFO_EN	SFLP_GBIAS_FIFO_EN	SFLP_GRAVITY_FIFO_EN	0 <sup>(1)</sup>	0 <sup>(1)</sup>	SFLP_GAME_FIFO_EN	0 <sup>(1)</sup>
-------------	----------------------	--------------------	----------------------	------------------	------------------	-------------------	------------------

1. This bit must be set to 0 for the correct operation of the device.

**Table 336. EMB\_FUNC\_FIFO\_EN\_A register description**

MLC_FIFO_EN	Enables batching the machine learning core results in the FIFO buffer. Default value: 0 (0: disabled; 1: enabled)
STEP_COUNTER_FIFO_EN	Enables batching the step counter values in the FIFO buffer. Default value: 0 (0: disabled; 1: enabled)
SFLP_GBIAS_FIFO_EN	Enables batching the gyroscope bias values computed by the SFLP algorithm in the FIFO buffer. Default value: 0 (0: disabled; 1: enabled)
SFLP_GRAVITY_FIFO_EN	Enables batching the gravity values computed by the SFLP algorithm in the FIFO buffer. Default value: 0 (0: disabled; 1: enabled)
SFLP_GAME_FIFO_EN	Enables batching the game rotation vector (quaternion) values computed by the SFLP algorithm in the FIFO buffer. Default value: 0 (0: disabled; 1: enabled)

### 13.31 EMB\_FUNC\_FIFO\_EN\_B (45h)

Embedded functions FIFO configuration register B (R/W)

**Table 337. EMB\_FUNC\_FIFO\_EN\_B register**

0 <sup>(1)</sup>	0 <sup>(1)</sup>	0 <sup>(1)</sup>	0 <sup>(1)</sup>	0 <sup>(1)</sup>	0 <sup>(1)</sup>	MLC_FILTER_FEATURE_FIFO_EN	0 <sup>(1)</sup>
------------------	------------------	------------------	------------------	------------------	------------------	----------------------------	------------------

1. This bit must be set to 0 for the correct operation of the device.

**Table 338. EMB\_FUNC\_FIFO\_EN\_B register description**

MLC_FILTER_FEATURE_FIFO_EN	Enables batching the machine learning core filters and features in the FIFO buffer. Default value: 0 (0: disabled; 1: enabled)
----------------------------	--

### 13.32 FSM\_ENABLE (46h)

Enable FSM register (R/W)

**Table 339. FSM\_ENABLE register**

FSM8_EN	FSM7_EN	FSM6_EN	FSM5_EN	FSM4_EN	FSM3_EN	FSM2_EN	FSM1_EN
---------	---------	---------	---------	---------	---------	---------	---------

**Table 340. FSM\_ENABLE register description**

FSM8_EN	Enables FSM8. Default value: 0 (0: FSM8 disabled; 1: FSM8 enabled)
FSM7_EN	Enables FSM7. Default value: 0 (0: FSM7 disabled; 1: FSM7 enabled)
FSM6_EN	Enables FSM6. Default value: 0 (0: FSM6 disabled; 1: FSM6 enabled)
FSM5_EN	Enables FSM5. Default value: 0 (0: FSM5 disabled; 1: FSM5 enabled)
FSM4_EN	Enables FSM4. Default value: 0 (0: FSM4 disabled; 1: FSM4 enabled)
FSM3_EN	Enables FSM3. Default value: 0 (0: FSM3 disabled; 1: FSM3 enabled)
FSM2_EN	Enables FSM2. Default value: 0 (0: FSM2 disabled; 1: FSM2 enabled)
FSM1_EN	Enables FSM1. Default value: 0 (0: FSM1 disabled; 1: FSM1 enabled)

### 13.33 FSM\_LONG\_COUNTER\_L (48h) and FSM\_LONG\_COUNTER\_H (49h)

FSM long counter status register (R/W)

The long counter value is an unsigned integer value (16-bit format).

**Table 341. FSM\_LONG\_COUNTER\_L register**

FSM_LC_7	FSM_LC_6	FSM_LC_5	FSM_LC_4	FSM_LC_3	FSM_LC_2	FSM_LC_1	FSM_LC_0
----------	----------	----------	----------	----------	----------	----------	----------

**Table 342. FSM\_LONG\_COUNTER\_L register description**

FSM_LC_[7:0]	Long counter current value (LSbyte). Default value: 00000000
--------------	--

**Table 343. FSM\_LONG\_COUNTER\_H register**

FSM_LC_15	FSM_LC_14	FSM_LC_13	FSM_LC_12	FSM_LC_11	FSM_LC_10	FSM_LC_9	FSM_LC_8
-----------	-----------	-----------	-----------	-----------	-----------	----------	----------

**Table 344. FSM\_LONG\_COUNTER\_H register description**

FSM_LC_[15:8]	Long counter current value (MSbyte). Default value: 00000000
---------------	--

### 13.34 INT\_ACK\_MASK (4Bh)

Reset status register (R/W)

**Table 345. INT\_ACK\_MASK register**

IACK_MASK7	IACK_MASK6	IACK_MASK5	IACK_MASK4	IACK_MASK3	IACK_MASK2	IACK_MASK1	IACK_MASK0
------------	------------	------------	------------	------------	------------	------------	------------

**Table 346. INT\_ACK\_MASK register description**

IACK_MASK7	If set to 1, when reading the EMB_FUNC_STATUS (12h) / EMB_FUNC_STATUS_MAINPAGE (49h), FSM_STATUS (13h) / FSM_STATUS_MAINPAGE (4Ah) and MLC_STATUS (15h) / MLC_STATUS_MAINPAGE (4Bh) registers in latched mode (when the EMB_FUNC_LIR bit is set to 1 in the PAGE_RW (17h) register), bit 7 of the status register is not reset. When this bit is set to 0, bit 7 of the status register is reset. Default value: 0
IACK_MASK6	If set to 1, when reading the EMB_FUNC_STATUS (12h) / EMB_FUNC_STATUS_MAINPAGE (49h), FSM_STATUS (13h) / FSM_STATUS_MAINPAGE (4Ah) and MLC_STATUS (15h) / MLC_STATUS_MAINPAGE (4Bh) registers in latched mode (when the EMB_FUNC_LIR bit is set to 1 in the PAGE_RW (17h) register), bit 6 of the status register is not reset. When this bit is set to 0, bit 6 of the status register is reset. Default value: 0
IACK_MASK5	If set to 1, when reading the EMB_FUNC_STATUS (12h) / EMB_FUNC_STATUS_MAINPAGE (49h), FSM_STATUS (13h) / FSM_STATUS_MAINPAGE (4Ah) and MLC_STATUS (15h) / MLC_STATUS_MAINPAGE (4Bh) registers in latched mode (when the EMB_FUNC_LIR bit is set to 1 in the PAGE_RW (17h) register), bit 5 of the status register is not reset. When this bit is set to 0, bit 5 of the status register is reset. Default value: 0
IACK_MASK4	If set to 1, when reading the EMB_FUNC_STATUS (12h) / EMB_FUNC_STATUS_MAINPAGE (49h), FSM_STATUS (13h) / FSM_STATUS_MAINPAGE (4Ah) and MLC_STATUS (15h) / MLC_STATUS_MAINPAGE (4Bh) registers in latched mode (when the EMB_FUNC_LIR bit is set to 1 in the PAGE_RW (17h) register), bit 4 of the status register is not reset. When this bit is set to 0, bit 4 of the status register is reset. Default value: 0
IACK_MASK3	If set to 1, when reading the EMB_FUNC_STATUS (12h) / EMB_FUNC_STATUS_MAINPAGE (49h), FSM_STATUS (13h) / FSM_STATUS_MAINPAGE (4Ah) and MLC_STATUS (15h) / MLC_STATUS_MAINPAGE (4Bh) registers in latched mode (when the EMB_FUNC_LIR bit is set to 1 in the PAGE_RW (17h) register), bit 3 of the status register is not reset. When this bit is set to 0, bit 3 of the status register is reset. Default value: 0
IACK_MASK2	If set to 1, when reading the EMB_FUNC_STATUS (12h) / EMB_FUNC_STATUS_MAINPAGE (49h), FSM_STATUS (13h) / FSM_STATUS_MAINPAGE (4Ah) and MLC_STATUS (15h) / MLC_STATUS_MAINPAGE (4Bh) registers in latched mode (when the EMB_FUNC_LIR bit is set to 1 in the PAGE_RW (17h) register), bit 2 of the status register is not reset. When this bit is set to 0, bit 2 of the status register is reset. Default value: 0
IACK_MASK1	If set to 1, when reading the EMB_FUNC_STATUS (12h) / EMB_FUNC_STATUS_MAINPAGE (49h), FSM_STATUS (13h) / FSM_STATUS_MAINPAGE (4Ah) and MLC_STATUS (15h) / MLC_STATUS_MAINPAGE (4Bh) registers in latched mode (when the EMB_FUNC_LIR bit is set to 1 in the PAGE_RW (17h) register), bit 1 of the status register is not reset. When this bit is set to 0, bit 1 of the status register is reset. Default value: 0
IACK_MASK0	If set to 1, when reading the EMB_FUNC_STATUS (12h) / EMB_FUNC_STATUS_MAINPAGE (49h), FSM_STATUS (13h) / FSM_STATUS_MAINPAGE (4Ah) and MLC_STATUS (15h) / MLC_STATUS_MAINPAGE (4Bh) registers in latched mode (when the EMB_FUNC_LIR bit is set to 1 in the PAGE_RW (17h) register), bit 0 of the status register is not reset. When this bit is set to 0, bit 0 of the status register is reset. Default value: 0

### 13.35 FSM\_OUTS1 (4Ch)

FSM1 output register (R)

**Table 347. FSM\_OUTS1 register**

P_X	N_X	P_Y	N_Y	P_Z	N_Z	P_V	N_V
-----	-----	-----	-----	-----	-----	-----	-----

**Table 348. FSM\_OUTS1 register description**

P_X	FSM1 output: positive event detected on the X-axis. (0: event not detected; 1: event detected)
N_X	FSM1 output: negative event detected on the X-axis. (0: event not detected; 1: event detected)
P_Y	FSM1 output: positive event detected on the Y-axis. (0: event not detected; 1: event detected)
N_Y	FSM1 output: negative event detected on the Y-axis. (0: event not detected; 1: event detected)
P_Z	FSM1 output: positive event detected on the Z-axis. (0: event not detected; 1: event detected)
N_Z	FSM1 output: negative event detected on the Z-axis. (0: event not detected; 1: event detected)
P_V	FSM1 output: positive event detected on the vector. (0: event not detected; 1: event detected)
N_V	FSM1 output: negative event detected on the vector. (0: event not detected; 1: event detected)

### 13.36 FSM\_OUTS2 (4Dh)

FSM2 output register (R)

**Table 349. FSM\_OUTS2 register**

P_X	N_X	P_Y	N_Y	P_Z	N_Z	P_V	N_V
-----	-----	-----	-----	-----	-----	-----	-----

**Table 350. FSM\_OUTS2 register description**

P_X	FSM2 output: positive event detected on the X-axis. (0: event not detected; 1: event detected)
N_X	FSM2 output: negative event detected on the X-axis. (0: event not detected; 1: event detected)
P_Y	FSM2 output: positive event detected on the Y-axis. (0: event not detected; 1: event detected)
N_Y	FSM2 output: negative event detected on the Y-axis. (0: event not detected; 1: event detected)
P_Z	FSM2 output: positive event detected on the Z-axis. (0: event not detected; 1: event detected)
N_Z	FSM2 output: negative event detected on the Z-axis. (0: event not detected; 1: event detected)
P_V	FSM2 output: positive event detected on the vector. (0: event not detected; 1: event detected)
N_V	FSM2 output: negative event detected on the vector. (0: event not detected; 1: event detected)

### 13.37 FSM\_OUTS3 (4Eh)

FSM3 output register (R)

**Table 351. FSM\_OUTS3 register**

P_X	N_X	P_Y	N_Y	P_Z	N_Z	P_V	N_V
-----	-----	-----	-----	-----	-----	-----	-----

**Table 352. FSM\_OUTS3 register description**

P_X	FSM3 output: positive event detected on the X-axis. (0: event not detected; 1: event detected)
N_X	FSM3 output: negative event detected on the X-axis. (0: event not detected; 1: event detected)
P_Y	FSM3 output: positive event detected on the Y-axis. (0: event not detected; 1: event detected)
N_Y	FSM3 output: negative event detected on the Y-axis. (0: event not detected; 1: event detected)
P_Z	FSM3 output: positive event detected on the Z-axis. (0: event not detected; 1: event detected)
N_Z	FSM3 output: negative event detected on the Z-axis. (0: event not detected; 1: event detected)
P_V	FSM3 output: positive event detected on the vector. (0: event not detected; 1: event detected)
N_V	FSM3 output: negative event detected on the vector. (0: event not detected; 1: event detected)

### 13.38 FSM\_OUTS4 (4Fh)

FSM4 output register (R)

**Table 353. FSM\_OUTS4 register**

P_X	N_X	P_Y	N_Y	P_Z	N_Z	P_V	N_V
-----	-----	-----	-----	-----	-----	-----	-----

**Table 354. FSM\_OUTS4 register description**

P_X	FSM4 output: positive event detected on the X-axis. (0: event not detected; 1: event detected)
N_X	FSM4 output: negative event detected on the X-axis. (0: event not detected; 1: event detected)
P_Y	FSM4 output: positive event detected on the Y-axis. (0: event not detected; 1: event detected)
N_Y	FSM4 output: negative event detected on the Y-axis. (0: event not detected; 1: event detected)
P_Z	FSM4 output: positive event detected on the Z-axis. (0: event not detected; 1: event detected)
N_Z	FSM4 output: negative event detected on the Z-axis. (0: event not detected; 1: event detected)
P_V	FSM4 output: positive event detected on the vector. (0: event not detected; 1: event detected)
N_V	FSM4 output: negative event detected on the vector. (0: event not detected; 1: event detected)

### 13.39 FSM\_OUTS5 (50h)

FSM5 output register (R)

**Table 355. FSM\_OUTS5 register**

P_X	N_X	P_Y	N_Y	P_Z	N_Z	P_V	N_V
-----	-----	-----	-----	-----	-----	-----	-----

**Table 356. FSM\_OUTS5 register description**

P_X	FSM5 output: positive event detected on the X-axis. (0: event not detected; 1: event detected)
N_X	FSM5 output: negative event detected on the X-axis. (0: event not detected; 1: event detected)
P_Y	FSM5 output: positive event detected on the Y-axis. (0: event not detected; 1: event detected)
N_Y	FSM5 output: negative event detected on the Y-axis. (0: event not detected; 1: event detected)
P_Z	FSM5 output: positive event detected on the Z-axis. (0: event not detected; 1: event detected)
N_Z	FSM5 output: negative event detected on the Z-axis. (0: event not detected; 1: event detected)
P_V	FSM5 output: positive event detected on the vector. (0: event not detected; 1: event detected)
N_V	FSM5 output: negative event detected on the vector. (0: event not detected; 1: event detected)

### 13.40 FSM\_OUTS6 (51h)

FSM6 output register (R)

**Table 357. FSM\_OUTS6 register**

P_X	N_X	P_Y	N_Y	P_Z	N_Z	P_V	N_V
-----	-----	-----	-----	-----	-----	-----	-----

**Table 358. FSM\_OUTS6 register description**

P_X	FSM6 output: positive event detected on the X-axis. (0: event not detected; 1: event detected)
N_X	FSM6 output: negative event detected on the X-axis. (0: event not detected; 1: event detected)
P_Y	FSM6 output: positive event detected on the Y-axis. (0: event not detected; 1: event detected)
N_Y	FSM6 output: negative event detected on the Y-axis. (0: event not detected; 1: event detected)
P_Z	FSM6 output: positive event detected on the Z-axis. (0: event not detected; 1: event detected)
N_Z	FSM6 output: negative event detected on the Z-axis. (0: event not detected; 1: event detected)
P_V	FSM6 output: positive event detected on the vector. (0: event not detected; 1: event detected)
N_V	FSM6 output: negative event detected on the vector. (0: event not detected; 1: event detected)

### 13.41 FSM\_OUTS7 (52h)

FSM7 output register (R)

**Table 359. FSM\_OUTS7 register**

P_X	N_X	P_Y	N_Y	P_Z	N_Z	P_V	N_V
-----	-----	-----	-----	-----	-----	-----	-----

**Table 360. FSM\_OUTS7 register description**

P_X	FSM7 output: positive event detected on the X-axis. (0: event not detected; 1: event detected)
N_X	FSM7 output: negative event detected on the X-axis. (0: event not detected; 1: event detected)
P_Y	FSM7 output: positive event detected on the Y-axis. (0: event not detected; 1: event detected)
N_Y	FSM7 output: negative event detected on the Y-axis. (0: event not detected; 1: event detected)
P_Z	FSM7 output: positive event detected on the Z-axis. (0: event not detected; 1: event detected)
N_Z	FSM7 output: negative event detected on the Z-axis. (0: event not detected; 1: event detected)
P_V	FSM7 output: positive event detected on the vector. (0: event not detected; 1: event detected)
N_V	FSM7 output: negative event detected on the vector. (0: event not detected; 1: event detected)

### 13.42 FSM\_OUTS8 (53h)

FSM8 output register (R)

**Table 361. FSM\_OUTS8 register**

P_X	N_X	P_Y	N_Y	P_Z	N_Z	P_V	N_V
-----	-----	-----	-----	-----	-----	-----	-----

**Table 362. FSM\_OUTS8 register description**

P_X	FSM8 output: positive event detected on the X-axis. (0: event not detected; 1: event detected)
N_X	FSM8 output: negative event detected on the X-axis. (0: event not detected; 1: event detected)
P_Y	FSM8 output: positive event detected on the Y-axis. (0: event not detected; 1: event detected)
N_Y	FSM8 output: negative event detected on the Y-axis. (0: event not detected; 1: event detected)
P_Z	FSM8 output: positive event detected on the Z-axis. (0: event not detected; 1: event detected)
N_Z	FSM8 output: negative event detected on the Z-axis. (0: event not detected; 1: event detected)
P_V	FSM8 output: positive event detected on the vector. (0: event not detected; 1: event detected)
N_V	FSM8 output: negative event detected on the vector. (0: event not detected; 1: event detected)

### 13.43 SFLP\_ODR (5Eh)

Sensor fusion low-power output data rate configuration register (R/W)

**Table 363. SFLP\_ODR register**

0 <sup>(1)</sup>	1 <sup>(2)</sup>	SFLP_GAME_ODR_2	SFLP_GAME_ODR_1	SFLP_GAME_ODR_0	0 <sup>(1)</sup>	1 <sup>(2)</sup>	1 <sup>(2)</sup>
------------------	------------------	-----------------	-----------------	-----------------	------------------	------------------	------------------

1. This bit must be set to 0 for the correct operation of the device.
2. This bit must be set to 1 for the correct operation of the device.

**Table 364. SFLP\_ODR register description**

SFLP_GAME_ODR_[2:0]	ODR configuration of the SFLP game algorithm: (000: 15 Hz; 001: 30 Hz; 010: 60 Hz; 011: 120 Hz (default); 100: 240 Hz; 101: 480 Hz)
---------------------	---

### 13.44 FSM\_ODR (5Fh)

Finite state machine output data rate configuration register (R/W)

**Table 365. FSM\_ODR register**

0 <sup>(1)</sup>	1 <sup>(2)</sup>	FSM_ODR_2	FSM_ODR_1	FSM_ODR_0	0 <sup>(1)</sup>	1 <sup>(2)</sup>	1 <sup>(2)</sup>
------------------	------------------	-----------	-----------	-----------	------------------	------------------	------------------

1. This bit must be set to 0 for the correct operation of the device.
2. This bit must be set to 1 for the correct operation of the device.

**Table 366. FSM\_ODR register description**

FSM_ODR_[2:0]	Finite state machine ODR configuration: (000: 15 Hz; 001: 30 Hz (default); 010: 60 Hz; 011: 120 Hz; 100: 240 Hz; 101: 480 Hz; 110: 960 Hz)
---------------	---

### 13.45 MLC\_ODR (60h)

Machine learning core output data rate configuration register (R/W)

**Table 367. MLC\_ODR register**

0 <sup>(1)</sup>	MLC_ODR_2	MLC_ODR_1	MLC_ODR_0	0 <sup>(1)</sup>	1 <sup>(2)</sup>	0 <sup>(1)</sup>	1 <sup>(2)</sup>
------------------	-----------	-----------	-----------	------------------	------------------	------------------	------------------

1. This bit must be set to 0 for the correct operation of the device.
2. This bit must be set to 1 for the correct operation of the device.

**Table 368. MLC\_ODR register description**

MLC_ODR_[2:0]	Machine learning core ODR configuration: (000: 15 Hz; 001: 30 Hz (default); 010: 60 Hz; 011: 120 Hz; 100: 240 Hz; 101: 480 Hz; 110: 960 Hz)
---------------	--

### 13.46 STEP\_COUNTER\_L (62h) and STEP\_COUNTER\_H (63h)

Step counter output register (R)

**Table 369. STEP\_COUNTER\_L register**

STEP_7	STEP_6	STEP_5	STEP_4	STEP_3	STEP_2	STEP_1	STEP_0
--------	--------	--------	--------	--------	--------	--------	--------

**Table 370. STEP\_COUNTER\_L register description**

STEP_[7:0]	Step counter output (LSbyte)
------------	------------------------------

**Table 371. STEP\_COUNTER\_H register**

STEP_15	STEP_14	STEP_13	STEP_12	STEP_11	STEP_10	STEP_9	STEP_8
---------	---------	---------	---------	---------	---------	--------	--------

**Table 372. STEP\_COUNTER\_H register description**

STEP_[15:8]	Step counter output (MSbyte)
-------------	------------------------------

## 13.47 EMB\_FUNC\_SRC (64h)

Embedded function source register (R/W)

**Table 373. EMB\_FUNC\_SRC register**

PEDO_RST_STEP	0 <sup>(1)</sup>	STEP_DETECTED	STEP_COUNT_DELTA_IA	STEP_OVERFLOW	STEP_COUNTER_BIT_SET	0 <sup>(1)</sup>	0 <sup>(1)</sup>
---------------	------------------	---------------	---------------------	---------------	----------------------	------------------	------------------

1. This bit must be set to 0 for the correct operation of the device.

**Table 374. EMB\_FUNC\_SRC register description**

PEDO_RST_STEP	Reset pedometer step counter. Read/write bit. (0: disabled; 1: enabled)
STEP_DETECTED	Step detector event detection status. Read-only bit. (0: step detection event not detected; 1: step detection event detected)
STEP_COUNT_DELTA_IA	Pedometer step recognition on delta time status. Read-only bit. (0: no step recognized during delta time; 1: at least one step recognized during delta time)
STEP_OVERFLOW	Step counter overflow status. Read-only bit. (0: step counter value < 2 <sup>16</sup> ; 1: step counter value reached 2 <sup>16</sup> )
STEP_COUNTER_BIT_SET	This bit is equal to 1 when the step count is increased. If a timer period is programmed in PEDO_SC_DELTAT_L (D0h) and PEDO_SC_DELTAT_H (D1h) embedded advanced features (page 1) registers, this bit is kept at 0. Read-only bit.

### 13.48 EMB\_FUNC\_INIT\_A (66h)

Embedded functions initialization register (R/W)

**Table 375. EMB\_FUNC\_INIT\_A register**

MLC_BEFORE_FSM_INIT	0 <sup>(1)</sup>	SIG_MOT_INIT	TILT_INIT	STEP_DET_INIT	0 <sup>(1)</sup>	SFLP_GAME_INIT	0 <sup>(1)</sup>
---------------------	------------------	--------------	-----------	---------------	------------------	----------------	------------------

1. This bit must be set to 0 for the correct operation of the device.

**Table 376. EMB\_FUNC\_INIT\_A register description**

MLC_BEFORE_FSM_INIT	Machine learning core initialization request (MLC executed before FSM). Default value: 0
SIG_MOT_INIT	Significant motion detection algorithm initialization request. Default value: 0
TILT_INIT	Tilt algorithm initialization request. Default value: 0
STEP_DET_INIT	Pedometer step counter/detector algorithm initialization request. Default value: 0
SFLP_GAME_INIT	SFLP game algorithm initialization request. Default value: 0

### 13.49 EMB\_FUNC\_INIT\_B (67h)

Embedded functions initialization register (R/W)

**Table 377. EMB\_FUNC\_INIT\_B register**

0 <sup>(1)</sup>	0 <sup>(1)</sup>	0 <sup>(1)</sup>	MLC_INIT	FIFO_COMPR_INIT	0 <sup>(1)</sup>	0 <sup>(1)</sup>	FSM_INIT
------------------	------------------	------------------	----------	-----------------	------------------	------------------	----------

1. This bit must be set to 0 for the correct operation of the device.

**Table 378. EMB\_FUNC\_INIT\_B register description**

MLC_INIT	Machine learning core initialization request (MLC executed after FSM). Default value: 0
FIFO_COMPR_INIT	FIFO compression feature initialization request. Default value: 0
FSM_INIT	FSM initialization request. Default value: 0

### 13.50 EMB\_FUNC\_SENSOR\_CONV\_EN (6Eh)

Embedded functions sensor conversion enable/disable register (R/W)

**Table 379. EMB\_FUNC\_SENSOR\_CONV\_EN register**

0 <sup>(1)</sup>	0 <sup>(1)</sup>	0 <sup>(1)</sup>	0 <sup>(1)</sup>	EXT_SENSOR_CONV_EN	TEMP_CONV_EN	GYRO_CONV_EN	XL_HG_CONV_EN
------------------	------------------	------------------	------------------	--------------------	--------------	--------------	---------------

1. This bit must be set to 0 for the correct operation of the device.

**Table 380. EMB\_FUNC\_SENSOR\_CONV\_EN register description**

EXT_SENSOR_CONV_EN	Enables/disables the external sensor data conversion for the embedded functions. Default value: 1 (0: data conversion disabled; 1: data conversion enabled)
TEMP_CONV_EN	Enables/disables the temperature data conversion for the embedded functions. Default value: 1 (0: data conversion disabled; 1: data conversion enabled)
GYRO_CONV_EN	Enables/disables the gyroscope data conversion for the embedded functions. Default value: 1 (0: data conversion disabled; 1: data conversion enabled)
XL_HG_CONV_EN	Enables/disables the high-g accelerometer data conversion for the embedded functions. Default value: 1 (0: data conversion disabled; 1: data conversion enabled)

### 13.51 MLC1\_SRC (70h)

Machine learning core source register (R)

**Table 381. MLC1\_SRC register**

MLC1_SRC_7	MLC1_SRC_6	MLC1_SRC_5	MLC1_SRC_4	MLC1_SRC_3	MLC1_SRC_2	MLC1_SRC_1	MLC1_SRC_0
------------	------------	------------	------------	------------	------------	------------	------------

**Table 382. MLC1\_SRC register description**

MLC1_SRC_[7:0]	Output value of MLC1 decision tree
----------------	------------------------------------

### 13.52 MLC2\_SRC (71h)

Machine learning core source register (R)

**Table 383. MLC2\_SRC register**

MLC2_SRC_7	MLC2_SRC_6	MLC2_SRC_5	MLC2_SRC_4	MLC2_SRC_3	MLCS2_SRC_2	MLC2_SRC_1	MLC2_SRC_0
------------	------------	------------	------------	------------	-------------	------------	------------

**Table 384. MLC2\_SRC register description**

MLC2_SRC_[7:0]	Output value of MLC2 decision tree
----------------	------------------------------------

### 13.53 MLC3\_SRC (72h)

Machine learning core source register (R)

**Table 385. MLC3\_SRC register**

MLC3_SRC_7	MLC3_SRC_6	MLC3_SRC_5	MLC3_SRC_4	MLC3_SRC_3	MLC3_SRC_2	MLC3_SRC_1	MLC3_SRC_0
------------	------------	------------	------------	------------	------------	------------	------------

**Table 386. MLC3\_SRC register description**

MLC3_SRC_[7:0]	Output value of MLC3 decision tree
----------------	------------------------------------

### 13.54 MLC4\_SRC (73h)

Machine learning core source register (R)

**Table 387. MLC4\_SRC register**

MLC4_SRC_7	MLC4_SRC_6	MLC4_SRC_5	MLC4_SRC_4	MLC4_SRC_3	MLC4_SRC_2	MLC4_SRC_1	MLC4_SRC_0
------------	------------	------------	------------	------------	------------	------------	------------

**Table 388. MLC4\_SRC register description**

MLC4_SRC_[7:0]	Output value of MLC4 decision tree
----------------	------------------------------------

### 13.55 MLC5\_SRC (74h)

Machine learning core source register (R)

**Table 389. MLC5\_SRC register**

MLC5_SRC_7	MLC5_SRC_6	MLC5_SRC_5	MLC5_SRC_4	MLC5_SRC_3	MLC5_SRC_2	MLC5_SRC_1	MLC5_SRC_0
------------	------------	------------	------------	------------	------------	------------	------------

**Table 390. MLC5\_SRC register description**

MLC5_SRC_[7:0]	Output value of MLC5 decision tree
----------------	------------------------------------

### 13.56 MLC6\_SRC (75h)

Machine learning core source register (R)

**Table 391. MLC6\_SRC register**

MLC6_SRC_7	MLC6_SRC_6	MLC6_SRC_5	MLC6_SRC_4	MLC6_SRC_3	MLC6_SRC_2	MLC6_SRC_1	MLC6_SRC_0
------------	------------	------------	------------	------------	------------	------------	------------

**Table 392. MLC6\_SRC register description**

MLC6_SRC_[7:0]	Output value of MLC6 decision tree
----------------	------------------------------------

### 13.57 MLC7\_SRC (76h)

Machine learning core source register (R)

**Table 393. MLC7\_SRC register**

MLC7_SRC_7	MLC7_SRC_6	MLC7_SRC_5	MLC7_SRC_4	MLC7_SRC_3	MLC7_SRC_2	MLC7_SRC_1	MLC7_SRC_0
------------	------------	------------	------------	------------	------------	------------	------------

**Table 394. MLC7\_SRC register description**

MLC7_SRC_[7:0]	Output value of MLC7 decision tree
----------------	------------------------------------

### 13.58 MLC8\_SRC (77h)

Machine learning core source register (R)

**Table 395. MLC8\_SRC register**

MLC8_SRC_7	MLC8_SRC_6	MLC8_SRC_5	MLC8_SRC_4	MLC8_SRC_3	MLC8_SRC_2	MLC8_SRC_1	MLC8_SRC_0
------------	------------	------------	------------	------------	------------	------------	------------

**Table 396. MLC8\_SRC register description**

MLC8_SRC_[7:0]	Output value of MLC8 decision tree
----------------	------------------------------------

## 14 Embedded advanced features pages

The table given below provides a list of the registers for the embedded advanced features page 0. These registers are accessible when PAGE\_SEL[3:0] are set to 0000 in [PAGE\\_SEL \(02h\)](#).

*Note: External sensor offset compensation registers and transformation matrix correction registers affect FSM data only. When these registers are set with their default values, no compensation is applied.*

**Table 397. Register address map - embedded advanced features page 0**

Name	Type	Register address		Default	Comment
		Hex	Binary		
FSM_EXT_SENSITIVITY_L	R/W	BA	10111010	00100100	
FSM_EXT_SENSITIVITY_H	R/W	BB	10111011	00010110	
FSM_EXT_OFFFX_L	R/W	C0	11000000	00000000	
FSM_EXT_OFFFX_H	R/W	C1	11000001	00000000	
FSM_EXT_OFFFY_L	R/W	C2	11000010	00000000	
FSM_EXT_OFFFY_H	R/W	C3	11000011	00000000	
FSM_EXT_OFFFZ_L	R/W	C4	11000100	00000000	
FSM_EXT_OFFFZ_H	R/W	C5	11000101	00000000	
FSM_EXT_MATRIX_XX_L	R/W	C6	11000110	00000000	
FSM_EXT_MATRIX_XX_H	R/W	C7	11000111	00111100	
FSM_EXT_MATRIX_XY_L	R/W	C8	11001000	00000000	
FSM_EXT_MATRIX_XY_H	R/W	C9	11001001	00000000	
FSM_EXT_MATRIX_XZ_L	R/W	CA	11001010	00000000	
FSM_EXT_MATRIX_XZ_H	R/W	CB	11001011	00000000	
FSM_EXT_MATRIX_YY_L	R/W	CC	11001100	00000000	
FSM_EXT_MATRIX_YY_H	R/W	CD	11001101	00111100	
FSM_EXT_MATRIX_YZ_L	R/W	CE	11001110	00000000	
FSM_EXT_MATRIX_YZ_H	R/W	CF	11001111	00000000	
FSM_EXT_MATRIX_ZZ_L	R/W	D0	11010000	00000000	
FSM_EXT_MATRIX_ZZ_H	R/W	D1	11010001	00111100	
EXT_CFG_A	R/W	D4	11010100	00000101	
EXT_CFG_B	R/W	D5	11010101	00000010	

The following table provides a list of the registers for the embedded advanced features page 1. These registers are accessible when PAGE\_SEL[3:0] are set to 0001 in PAGE\_SEL (02h).

**Table 398. Register address map - embedded advanced features page 1**

Name	Type	Register address		Default	Comment
		Hex	Binary		
XL_HG_SENSITIVITY_L	R/W	58	01011000	00011111	
XL_HG_SENSITIVITY_H	R/W	59	01011001	00000101	
FSM_LC_TIMEOUT_L	R/W	7A	01111010	00000000	
FSM_LC_TIMEOUT_H	R/W	7B	01111011	00000000	
FSM_PROGRAMS	R/W	7C	01111100	00000000	
FSM_START_ADD_L	R/W	7E	01111110	00000000	
FSM_START_ADD_H	R/W	7F	01111111	00000000	
PEDO_CMD_REG	R/W	83	10000011	00000000	
PEDO_DEB_STEPS_CONF	R/W	84	10000100	00001010	
PEDO_SC_DELTAT_L	R/W	D0	11010000	00000000	
PEDO_SC_DELTAT_H	R/W	D1	11010001	00000000	
MLC_EXT_SENSITIVITY_L	R/W	E8	11101000	00000000	
MLC_EXT_SENSITIVITY_H	R/W	E9	11101001	00111100	

The following table provides a list of the registers for the embedded advanced features page 2. These registers are accessible when PAGE\_SEL[3:0] are set to 0010 in PAGE\_SEL (02h).

**Table 399. Register address map - embedded advanced features page 2**

Name	Type	Register address		Default	Comment
		Hex	Binary		
EXT_FORMAT	R/W	00	00000000	00000000	
EXT_3BYTE_SENSITIVITY_L	R/W	02	00000010	00000000	
EXT_3BYTE_SENSITIVITY_H	R/W	03	00000011	00001100	
EXT_3BYTE_OFFSET_XL	R/W	06	00000110	00000000	
EXT_3BYTE_OFFSET_L	R/W	07	00000111	01010100	
EXT_3BYTE_OFFSET_H	R/W	08	00001000	00111111	

Reserved registers must not be changed. Writing to those registers may cause permanent damage to the device. The content of the registers that are loaded at boot should not be changed. They contain the factory calibration values. Their content is automatically restored when the device is powered up.

**Write procedure example:** write value 06h in register at address 84h (PEDO\_DEB\_STEPS\_CONF) in Page 1

1. Write bit EMB\_FUNC\_REG\_ACCESS = 1 in FUNC\_CFG\_ACCESS (01h) // Enable access to embedded functions registers
2. Write bit PAGE\_WRITE = 1 in PAGE\_RW (17h) register // Select write operation mode
3. Write 0001 in PAGE\_SEL[3:0] field of register PAGE\_SEL (02h) // Select page 1
4. Write 84h in PAGE\_ADDR register (08h) // Set address
5. Write 06h in PAGE\_DATA register (09h) // Set value to be written
6. Write bit PAGE\_WRITE = 0 in PAGE\_RW (17h) register // Write operation disabled

7. Write bit EMB\_FUNC\_REG\_ACCESS = 0 in FUNC\_CFG\_ACCESS (01h) // Disable access to embedded functions registers

**Read procedure example:** read value of register at address 84h (PEDO\_DEB\_STEPS\_CONF) in Page 1

1. Write bit EMB\_FUNC\_REG\_ACCESS = 1 in FUNC\_CFG\_ACCESS (01h) // Enable access to embedded functions registers
2. Write bit PAGE\_READ = 1 in PAGE\_RW (17h) register // Select read operation mode
3. Write 0001 in PAGE\_SEL[3:0] field of register PAGE\_SEL (02h) // Select page 1
4. Write 84h in PAGE\_ADDR register (08h) // Set address
5. Read value of PAGE\_DATA register (09h) // Get register value
6. Write bit PAGE\_READ = 0 in PAGE\_RW (17h) register // Read operation disabled
7. Write bit EMB\_FUNC\_REG\_ACCESS = 0 in FUNC\_CFG\_ACCESS (01h) // Disable access to embedded functions registers

**Note:** *Steps 1 and 2 of both procedures are intended to be performed at the beginning of the procedure. Steps 6 and 7 of both procedures are intended to be performed at the end of the procedure. If the procedure involves multiple operations, only steps 3, 4 and 5 must be repeated for each operation. If, in particular, the multiple operations involve consecutive registers, only step 5 can be performed.*

## 15 Embedded advanced features register description

### 15.1 Page 0 - embedded advanced features registers

#### 15.1.1 FSM\_EXT\_SENSITIVITY\_L (BAh) and FSM\_EXT\_SENSITIVITY\_H (BBh)

External sensor sensitivity value register for the finite state machine (R/W)

This register corresponds to the conversion value of the external sensor. The register value is expressed as half-precision floating-point format: SEESEEEEEEEEEEE (S: 1 sign bit; E: 5 exponent bits; F: 10 fraction bits).

Default value of FSM\_EXT\_S\_[15:0] bits is 0x1624 (when using an external magnetometer this value corresponds to 0.0015 gauss/LSB).

**Table 400. FSM\_EXT\_SENSITIVITY\_L register**

FSM_EXT_ S_7	FSM_EXT_ S_6	FSM_EXT_ S_5	FSM_EXT_ S_4	FSM_EXT_ S_3	FSM_EXT_ S_2	FSM_EXT_ S_1	FSM_EXT_ S_0
-----------------	-----------------	-----------------	-----------------	-----------------	-----------------	-----------------	-----------------

**Table 401. FSM\_EXT\_SENSITIVITY\_L register description**

FSM_EXT_S_[7:0]	External sensor sensitivity (LSbyte). Default value: 00100100
-----------------	---

**Table 402. FSM\_EXT\_SENSITIVITY\_H register**

FSM_EXT_ S_15	FSM_EXT_ S_14	FSM_EXT_ S_13	FSM_EXT_ S_12	FSM_EXT_ S_11	FSM_EXT_ S_10	FSM_EXT_ S_9	FSM_EXT_ S_8
------------------	------------------	------------------	------------------	------------------	------------------	-----------------	-----------------

**Table 403. FSM\_EXT\_SENSITIVITY\_H register description**

FSM_EXT_S_[15:8]	External sensor (MSbyte). Default value: 00010110
------------------	---

**15.1.2 FSM\_EXT\_OFFX\_L (C0h) and FSM\_EXT\_OFFX\_H (C1h)**

External sensor X-axis offset

The value is expressed as half-precision floating-point format: SEEEEEEEEEEEEEE

(S: 1 sign bit; E: 5 exponent bits; F: 10 fraction bits).

**Table 404. FSM\_EXT\_OFFX\_L register**

FSM_EXT_OFFX_7	FSM_EXT_OFFX_6	FSM_EXT_OFFX_5	FSM_EXT_OFFX_4	FSM_EXT_OFFX_3	FSM_EXT_OFFX_2	FSM_EXT_OFFX_1	FSM_EXT_OFFX_0
----------------	----------------	----------------	----------------	----------------	----------------	----------------	----------------

**Table 405. FSM\_EXT\_OFFX\_L register description**

FSM_EXT_OFFX[7:0]	External sensor X-axis offset (LSbyte). Default value: 00000000
-------------------	---

**Table 406. FSM\_EXT\_OFFX\_H register**

FSM_EXT_OFFX_15	FSM_EXT_OFFX_14	FSM_EXT_OFFX_13	FSM_EXT_OFFX_12	FSM_EXT_OFFX_11	FSM_EXT_OFFX_10	FSM_EXT_OFFX_9	FSM_EXT_OFFX_8
-----------------	-----------------	-----------------	-----------------	-----------------	-----------------	----------------	----------------

**Table 407. FSM\_EXT\_OFFX\_H register description**

FSM_EXT_OFFX[15:8]	External sensor X-axis offset (MSbyte). Default value: 00000000
--------------------	---

**15.1.3 FSM\_EXT\_OFFY\_L (C2h) and FSM\_EXT\_OFFY\_H (C3h)**

External sensor Y-axis offset

The value is expressed as half-precision floating-point format: SEEEEEEEEEEEEEE

(S: 1 sign bit; E: 5 exponent bits; F: 10 fraction bits).

**Table 408. FSM\_EXT\_OFFY\_L register**

FSM_EXT_OFFY_7	FSM_EXT_OFFY_6	FSM_EXT_OFFY_5	FSM_EXT_OFFY_4	FSM_EXT_OFFY_3	FSM_EXT_OFFY_2	FSM_EXT_OFFY_1	FSM_EXT_OFFY_0
----------------	----------------	----------------	----------------	----------------	----------------	----------------	----------------

**Table 409. FSM\_EXT\_OFFY\_L register description**

FSM_EXT_OFFY[7:0]	External sensor Y-axis offset (LSbyte). Default value: 00000000
-------------------	---

**Table 410. FSM\_EXT\_OFFY\_H register**

FSM_EXT_OFFY_15	FSM_EXT_OFFY_14	FSM_EXT_OFFY_13	FSM_EXT_OFFY_12	FSM_EXT_OFFY_11	FSM_EXT_OFFY_10	FSM_EXT_OFFY_9	FSM_EXT_OFFY_8
-----------------	-----------------	-----------------	-----------------	-----------------	-----------------	----------------	----------------

**Table 411. FSM\_EXT\_OFFY\_H register description**

FSM_EXT_OFFY[15:8]	External sensor Y-axis offset (MSbyte). Default value: 00000000
--------------------	---

**15.1.4 FSM\_EXT\_OFFZ\_L (C4h) and FSM\_EXT\_OFFZ\_H (C5h)**

External sensor Z-axis offset register (R/W)

The value is expressed as half-precision floating-point format: SEEEEEEEEEEEEEE

(S: 1 sign bit; E: 5 exponent bits; F: 10 fraction bits).

**Table 412. FSM\_EXT\_OFFZ\_L register**

FSM_EXT_OFFZ_7	FSM_EXT_OFFZ_6	FSM_EXT_OFFZ_5	FSM_EXT_OFFZ_4	FSM_EXT_OFFZ_3	FSM_EXT_OFFZ_2	FSM_EXT_OFFZ_1	FSM_EXT_OFFZ_0
----------------	----------------	----------------	----------------	----------------	----------------	----------------	----------------

**Table 413. FSM\_EXT\_OFFZ\_L register description**

FSM_EXT_OFFZ_[7:0]	External sensor Z-axis offset (LSbyte). Default value: 00000000
--------------------	---

**Table 414. FSM\_EXT\_OFFZ\_H register**

FSM_EXT_OFFZ_15	FSM_EXT_OFFZ_14	FSM_EXT_OFFZ_13	FSM_EXT_OFFZ_12	FSM_EXT_OFFZ_11	FSM_EXT_OFFZ_10	FSM_EXT_OFFZ_9	FSM_EXT_OFFZ_8
-----------------	-----------------	-----------------	-----------------	-----------------	-----------------	----------------	----------------

**Table 415. FSM\_EXT\_OFFZ\_H register description**

FSM_EXT_OFFZ_[15:8]	External sensor Z-axis offset (MSbyte). Default value: 00000000
---------------------	---

**15.1.5 FSM\_EXT\_MATRIX\_XX\_L (C6h) and FSM\_EXT\_MATRIX\_XX\_H (C7h)**

External sensor transformation matrix register (R/W)

The value is expressed as half-precision floating-point format: SEEEEEEEEEEEEEE

(S: 1 sign bit; E: 5 exponent bits; F: 10 fraction bits).

**Table 416. FSM\_EXT\_MATRIX\_XX\_L register**

FSM_EXT_MAT_XX_7	FSM_EXT_MAT_XX_6	FSM_EXT_MAT_XX_5	FSM_EXT_MAT_XX_4	FSM_EXT_MAT_XX_3	FSM_EXT_MAT_XX_2	FSM_EXT_MAT_XX_1	FSM_EXT_MAT_XX_0
------------------	------------------	------------------	------------------	------------------	------------------	------------------	------------------

**Table 417. FSM\_EXT\_MATRIX\_XX\_L register description**

FSM_EXT_MAT_XX_[7:0]	Transformation matrix row1 col1 coefficient (LSbyte). Default value: 00000000
----------------------	---

**Table 418. FSM\_EXT\_MATRIX\_XX\_H register**

FSM_EXT_MAT_XX_15	FSM_EXT_MAT_XX_14	FSM_EXT_MAT_XX_13	FSM_EXT_MAT_XX_12	FSM_EXT_MAT_XX_11	FSM_EXT_MAT_XX_10	FSM_EXT_MAT_XX_9	FSM_EXT_MAT_XX_8
-------------------	-------------------	-------------------	-------------------	-------------------	-------------------	------------------	------------------

**Table 419. FSM\_EXT\_MATRIX\_XX\_H register description**

FSM_EXT_MAT_XX_[15:8]	Transformation matrix row1 col1 coefficient (MSbyte). Default value: 00111100
-----------------------	---

**15.1.6 FSM\_EXT\_MATRIX\_XY\_L (C8h) and FSM\_EXT\_MATRIX\_XY\_H (C9h)**

External sensor transformation matrix register (R/W)

The value is expressed as half-precision floating-point format: SEEEEEEEEEEEEEE

(S: 1 sign bit; E: 5 exponent bits; F: 10 fraction bits).

**Table 420. FSM\_EXT\_MATRIX\_XY\_L register**

FSM_EXT_MAT_XY_7	FSM_EXT_MAT_XY_6	FSM_EXT_MAT_XY_5	FSM_EXT_MAT_XY_4	FSM_EXT_MAT_XY_3	FSM_EXT_MAT_XY_2	FSM_EXT_MAT_XY_1	FSM_EXT_MAT_XY_0
------------------	------------------	------------------	------------------	------------------	------------------	------------------	------------------

**Table 421. FSM\_EXT\_MATRIX\_XY\_L register description**

FSM_EXT_MAT_XY_[7:0]	Transformation matrix row1 col2 (and row2 col1) coefficient (LSbyte). Default value: 00000000
----------------------	---

**Table 422. FSM\_EXT\_MATRIX\_XY\_H register**

FSM_EXT_XY_15	FSM_EXT_XY_14	FSM_EXT_XY_13	FSM_EXT_XY_12	FSM_EXT_XY_11	FSM_EXT_XY_10	FSM_EXT_XY_9	FSM_EXT_XY_8
---------------	---------------	---------------	---------------	---------------	---------------	--------------	--------------

**Table 423. FSM\_EXT\_MATRIX\_XY\_H register description**

FSM_EXT_MAT_XY_[15:8]	Transformation matrix row1 col2 (and row2 col1) coefficient (MSbyte). Default value: 00000000
-----------------------	---

**15.1.7 FSM\_EXT\_MATRIX\_XZ\_L (CAh) and FSM\_EXT\_MATRIX\_XZ\_H (CBh)**

External sensor transformation matrix register (R/W)

The value is expressed as half-precision floating-point format: SEEEEEEEEEEEEEE

(S: 1 sign bit; E: 5 exponent bits; F: 10 fraction bits).

**Table 424. FSM\_EXT\_MATRIX\_XZ\_L register**

FSM_EXT_MAT_XZ_7	FSM_EXT_MAT_XZ_6	FSM_EXT_MAT_XZ_5	FSM_EXT_MAT_XZ_4	FSM_EXT_MAT_XZ_3	FSM_EXT_MAT_XZ_2	FSM_EXT_MAT_XZ_1	FSM_EXT_MAT_XZ_0
------------------	------------------	------------------	------------------	------------------	------------------	------------------	------------------

**Table 425. FSM\_EXT\_MATRIX\_XZ\_L register description**

FSM_EXT_MAT_XZ_[7:0]	Transformation matrix row1 col3 (and row3 col1) coefficient (LSbyte). Default value: 00000000
----------------------	---

**Table 426. FSM\_EXT\_MATRIX\_XZ\_H register**

FSM_EXT_MAT_XZ_15	FSM_EXT_MAT_XZ_14	FSM_EXT_MAT_XZ_13	FSM_EXT_MAT_XZ_12	FSM_EXT_MAT_XZ_11	FSM_EXT_MAT_XZ_10	FSM_EXT_MAT_XZ_9	FSM_EXT_MAT_XZ_8
-------------------	-------------------	-------------------	-------------------	-------------------	-------------------	------------------	------------------

**Table 427. FSM\_EXT\_MATRIX\_XZ\_H register description**

FSM_EXT_MAT_XZ_[15:8]	Transformation matrix row1 col3 (and row3 col1) coefficient (MSbyte). Default value: 00000000
-----------------------	---

**15.1.8 FSM\_EXT\_MATRIX\_YY\_L (CCh) and FSM\_EXT\_MATRIX\_YY\_H (CDh)**

External sensor transformation matrix register (R/W)

The value is expressed as half-precision floating-point format: SEEEEEEEEEEEEEE

(S: 1 sign bit; E: 5 exponent bits; F: 10 fraction bits).

**Table 428. FSM\_EXT\_MATRIX\_YY\_L register**

FSM_EXT_MAT_YY_7	FSM_EXT_MAT_YY_6	FSM_EXT_MAT_YY_5	FSM_EXT_MAT_YY_4	FSM_EXT_MAT_YY_3	FSM_EXT_MAT_YY_2	FSM_EXT_MAT_YY_1	FSM_EXT_MAT_YY_0
------------------	------------------	------------------	------------------	------------------	------------------	------------------	------------------

**Table 429. FSM\_EXT\_MATRIX\_YY\_L register description**

FSM_EXT_MAT_YY_[7:0]	Transformation matrix row2 col2 coefficient (LSbyte). Default value: 00000000
----------------------	---

**Table 430. FSM\_EXT\_MATRIX\_YY\_H register**

FSM_EXT_MAT_YY_15	FSM_EXT_MAT_YY_14	FSM_EXT_MAT_YY_13	FSM_EXT_MAT_YY_12	FSM_EXT_MAT_YY_11	FSM_EXT_MAT_YY_10	FSM_EXT_MAT_YY_9	FSM_EXT_MAT_YY_8
-------------------	-------------------	-------------------	-------------------	-------------------	-------------------	------------------	------------------

**Table 431. FSM\_EXT\_MATRIX\_YY\_H register description**

FSM_EXT_MAT_YY_[15:8]	Transformation matrix row2 col2 coefficient (MSbyte). Default value: 00111100
-----------------------	---

**15.1.9 FSM\_EXT\_MATRIX\_YZ\_L (CEh) and FSM\_EXT\_MATRIX\_YZ\_H (CFh)**

External sensor transformation matrix register (R/W)

The value is expressed as half-precision floating-point format: SEEEEEEEEEEEEEE

(S: 1 sign bit; E: 5 exponent bits; F: 10 fraction bits).

**Table 432. FSM\_EXT\_MATRIX\_YZ\_L register**

FSM_EXT_MAT_YZ_7	FSM_EXT_MAT_YZ_6	FSM_EXT_MAT_YZ_5	FSM_EXT_MAT_YZ_4	FSM_EXT_MAT_YZ_3	FSM_EXT_MAT_YZ_2	FSM_EXT_MAT_YZ_1	FSM_EXT_MAT_YZ_0
------------------	------------------	------------------	------------------	------------------	------------------	------------------	------------------

**Table 433. FSM\_EXT\_MATRIX\_YZ\_L register description**

FSM_EXT_MAT_YZ_[7:0]	Transformation matrix row2 col3 (and row3 col2) coefficient (LSbyte). Default value: 00000000
----------------------	--

**Table 434. FSM\_EXT\_MATRIX\_YZ\_H register**

FSM_EXT_MAT_YZ_15	FSM_EXT_MAT_YZ_14	FSM_EXT_MAT_YZ_13	FSM_EXT_MAT_YZ_12	FSM_EXT_MAT_YZ_11	FSM_EXT_MAT_YZ_10	FSM_EXT_MAT_YZ_9	FSM_EXT_MAT_YZ_8
-------------------	-------------------	-------------------	-------------------	-------------------	-------------------	------------------	------------------

**Table 435. FSM\_EXT\_MATRIX\_YZ\_H register description**

FSM_EXT_MAT_YZ_[15:8]	Transformation matrix row2 col3 (and row3 col2) coefficient (MSbyte). Default value: 00000000
-----------------------	--

**15.1.10 FSM\_EXT\_MATRIX\_ZZ\_L (D0h) and FSM\_EXT\_MATRIX\_ZZ\_H (D1h)**

External sensor transformation matrix register (R/W)

The value is expressed as half-precision floating-point format: SEEEEEEEEEEEEEE

(S: 1 sign bit; E: 5 exponent bits; F: 10 fraction bits).

**Table 436. FSM\_EXT\_MATRIX\_ZZ\_L register**

FSM_EXT_MAT_ZZ_7	FSM_EXT_MAT_ZZ_6	FSM_EXT_MAT_ZZ_5	FSM_EXT_MAT_ZZ_4	FSM_EXT_MAT_ZZ_3	FSM_EXT_MAT_ZZ_2	FSM_EXT_MAT_ZZ_1	FSM_EXT_MAT_ZZ_0
------------------	------------------	------------------	------------------	------------------	------------------	------------------	------------------

**Table 437. FSM\_EXT\_MATRIX\_ZZ\_L register description**

FSM_EXT_MAT_ZZ_[7:0]	Transformation matrix row3 col3 coefficient (LSbyte). Default value: 00000000
----------------------	---

**Table 438. FSM\_EXT\_MATRIX\_ZZ\_H register**

FSM_EXT_MAT_ZZ_15	FSM_EXT_MAT_ZZ_14	FSM_EXT_MAT_ZZ_13	FSM_EXT_MAT_ZZ_12	FSM_EXT_MAT_ZZ_11	FSM_EXT_MAT_ZZ_10	FSM_EXT_MAT_ZZ_9	FSM_EXT_MAT_ZZ_8
-------------------	-------------------	-------------------	-------------------	-------------------	-------------------	------------------	------------------

**Table 439. FSM\_EXT\_MATRIX\_ZZ\_H register description**

FSM_EXT_MAT_ZZ_[15:8]	Transformation matrix row3 col3 coefficient (MSbyte). Default value: 00111100
-----------------------	---

**15.1.11 EXT\_CFG\_A (D4h)**

External sensor coordinates (Z and Y axes) rotation register (r/w).

**Table 440. EXT\_CFG\_A register**

0 <sup>(1)</sup>	EXT_Y_ AXIS2	EXT_Y_ AXIS1	EXT_Y_ AXIS0	0 <sup>(1)</sup>	EXT_Z_ AXIS2	EXT_Z_ AXIS1	EXT_Z_ AXIS0
------------------	-----------------	-----------------	-----------------	------------------	-----------------	-----------------	-----------------

1. This bit must be set to 0 for the correct operation of the device.

**Table 441. EXT\_CFG\_A description**

EXT_Y_AXIS[2:0]	External sensor Y-axis coordinates rotation (to be aligned to accelerometer/gyroscope axes orientation) (000: Y = Y; (default) 001: Y = -Y; 010: Y = X; 011: Y = -X; 100: Y = -Z; 101: Y = Z; Others: Y = Y)
EXT_Z_AXIS[2:0]	External sensor Z-axis coordinates rotation (to be aligned to accelerometer/gyroscope axes orientation) (000: Z = Y; 001: Z = -Y; 010: Z = X; 011: Z = -X; 100: Z = -Z; 101: Z = Z; (default) Others: Z = Y)

**15.1.12 EXT\_CFG\_B (D5h)**

External sensor coordinates (X-axis) rotation register (r/w).

**Table 442. EXT\_CFG\_B register**

0 <sup>(1)</sup>	0 <sup>(1)</sup>	0 <sup>(1)</sup>	0 <sup>(1)</sup>	0 <sup>(1)</sup>	EXT_X_ AXIS2	EXT_X_ AXIS1	EXT_X_ AXIS0
------------------	------------------	------------------	------------------	------------------	-----------------	-----------------	-----------------

1. This bit must be set to 0 for the correct operation of the device.

**Table 443. EXT\_CFG\_B description**

EXT_X_AXIS[2:0]	External sensor X-axis coordinates rotation (to be aligned to accelerometer/gyroscope axes orientation) (000: X = Y; 001: X = -Y; 010: X = X; (default) 011: X = -X; 100: X = -Z; 101: X = Z; Others: X = Y)
-----------------	---

## 15.2 Page 1 - embedded advanced features registers

### 15.2.1 XL\_HG\_SENSITIVITY\_L (58h) and XL\_HG\_SENSITIVITY\_H (59h)

High-g accelerometer sensitivity value register for the finite state machine and machine learning core (R/W)

This register corresponds to the conversion value of the high-g accelerometer sensor. The register value is expressed as half-precision floating-point format: S EEEEEEEEEEEEEEE (S: 1 sign bit; E: 5 exponent bits; F: 10 fraction bits).

The default value of XL\_HG\_S\_[15:0] is 0x051F (expressed in hundreds of *g*, then  $7.8e-5 * [100 g]$ ). If FS\_XL\_HG is  $\pm 256 g$ , the value to be loaded is 0x06D4 (corresponds to  $10.4e-5 * [100 g]$ )

**Table 444. XL\_HG\_SENSITIVITY\_L register**

XL_HG_S_7	XL_HG_S_6	XL_HG_S_5	XL_HG_S_4	XL_HG_S_3	XL_HG_S_2	XL_HG_S_1	XL_HG_S_0
-----------	-----------	-----------	-----------	-----------	-----------	-----------	-----------

**Table 445. XL\_HG\_SENSITIVITY\_L register description**

XL_HG_S_[7:0]	High-g accelerometer sensitivity (LSbyte). Default value: 00011111
---------------	--

**Table 446. XL\_HG\_SENSITIVITY\_H register**

XL_HG_S_15	XL_HG_S_14	XL_HG_S_13	XL_HG_S_12	XL_HG_S_11	XL_HG_S_10	XL_HG_S_9	XL_HG_S_8
------------	------------	------------	------------	------------	------------	-----------	-----------

**Table 447. XL\_HG\_SENSITIVITY\_H register description**

XL_HG_S_[15:8]	High-g accelerometer sensitivity (MSbyte). Default value: 00000101
----------------	--

### 15.2.2 FSM\_LC\_TIMEOUT\_L (7Ah) and FSM\_LC\_TIMEOUT\_H (7Bh)

FSM long counter timeout register (R/W)

The long counter timeout value is an unsigned integer value (16-bit format). When the long counter value reached this value, the FSM generates an interrupt.

**Table 448. FSM\_LC\_TIMEOUT\_L register**

FSM_LC_TIMEOUT7	FSM_LC_TIMEOUT6	FSM_LC_TIMEOUT5	FSM_LC_TIMEOUT4	FSM_LC_TIMEOUT3	FSM_LC_TIMEOUT2	FSM_LC_TIMEOUT1	FSM_LC_TIMEOUT0
-----------------	-----------------	-----------------	-----------------	-----------------	-----------------	-----------------	-----------------

**Table 449. FSM\_LC\_TIMEOUT\_L register description**

FSM_LC_TIMEOUT[7:0]	FSM long counter timeout value (LSbyte). Default value: 00000000
---------------------	--

**Table 450. FSM\_LC\_TIMEOUT\_H register**

FSM_LC_TIMEOUT15	FSM_LC_TIMEOUT14	FSM_LC_TIMEOUT13	FSM_LC_TIMEOUT12	FSM_LC_TIMEOUT11	FSM_LC_TIMEOUT10	FSM_LC_TIMEOUT9	FSM_LC_TIMEOUT8
------------------	------------------	------------------	------------------	------------------	------------------	-----------------	-----------------

**Table 451. FSM\_LC\_TIMEOUT\_H register description**

FSM_LC_TIMEOUT[15:8]	FSM long counter timeout value (MSbyte). Default value: 00000000
----------------------	--

**15.2.3 FSM\_PROGRAMS (7Ch)**

FSM number of programs register (R/W)

**Table 452. FSM\_PROGRAMS register**

FSM_N_PROG7	FSM_N_PROG6	FSM_N_PROG5	FSM_N_PROG4	FSM_N_PROG3	FSM_N_PROG2	FSM_N_PROG1	FSM_N_PROG0
-------------	-------------	-------------	-------------	-------------	-------------	-------------	-------------

**Table 453. FSM\_PROGRAMS register description**

FSM_N_PROG[7:0]	Number of FSM programs; must be less than or equal to 8. Default value: 00000000
-----------------	---

**15.2.4 FSM\_START\_ADD\_L (7Eh) and FSM\_START\_ADD\_H (7Fh)**

FSM start address register (R/W). First available address is 0x2F0.

**Table 454. FSM\_START\_ADD\_L register**

FSM_START7	FSM_START6	FSM_START5	FSM_START4	FSM_START3	FSM_START2	FSM_START1	FSM_START0
------------	------------	------------	------------	------------	------------	------------	------------

**Table 455. FSM\_START\_ADD\_L register description**

FSM_START[7:0]	FSM start address value (LSbyte). Default value: 00000000
----------------	---

**Table 456. FSM\_START\_ADD\_H register**

FSM_START15	FSM_START14	FSM_START13	FSM_START12	FSM_START11	FSM_START10	FSM_START9	FSM_START8
-------------	-------------	-------------	-------------	-------------	-------------	------------	------------

**Table 457. FSM\_START\_ADD\_H register description**

FSM_START[15:8]	FSM start address value (MSbyte). Default value: 00000000
-----------------	---

**15.2.5 PEDO\_CMD\_REG (83h)**

Pedometer configuration register (R/W)

**Table 458. PEDO\_CMD\_REG register**

0 <sup>(1)</sup>	0 <sup>(1)</sup>	0 <sup>(1)</sup>	0 <sup>(1)</sup>	CARRY_COUNT_EN	FP_REJECTION_EN	0 <sup>(1)</sup>	0 <sup>(1)</sup>
------------------	------------------	------------------	------------------	----------------	-----------------	------------------	------------------

1. This bit must be set to 0 for the correct operation of the device.

**Table 459. PEDO\_CMD\_REG register description**

CARRY_COUNT_EN	Set when user wants to generate interrupt only on count overflow event.
FP_REJECTION_EN <sup>(1)</sup>	Enables the false-positive rejection feature

1. This bit is activated if the MLC\_EN bit of EMB\_FUNC\_EN\_B (05h) or the MLC\_BEFORE\_FSM\_EN bit in the EMB\_FUNC\_EN\_A (04h) register is set to 1.

**15.2.6 PEDO\_DEB\_STEPS\_CONF (84h)**

Pedometer debounce configuration register (R/W)

**Table 460. PEDO\_DEB\_STEPS\_CONF register**

DEB_STEP7	DEB_STEP6	DEB_STEP5	DEB_STEP4	DEB_STEP3	DEB_STEP2	DEB_STEP1	DEB_STEP0
-----------	-----------	-----------	-----------	-----------	-----------	-----------	-----------

**Table 461. PEDO\_DEB\_STEPS\_CONF register description**

DEB_STEP[7:0]	Debounce threshold. Minimum number of steps to increment the step counter (debounce). Default value: 00001010
---------------	--

**15.2.7 PEDO\_SC\_DELTAT\_L (D0h) and PEDO\_SC\_DELTAT\_H (D1h)**

Time period register for step detection on delta time (R/W)

**Table 462. PEDO\_SC\_DELTAT\_L register**

PD_SC_7	PD_SC_6	PD_SC_5	PD_SC_4	PD_SC_3	PD_SC_2	PD_SC_1	PD_SC_0
---------	---------	---------	---------	---------	---------	---------	---------

**Table 463. PEDO\_SC\_DELTAT\_H register**

PD_SC_15	PD_SC_14	PD_SC_13	PD_SC_12	PD_SC_11	PD_SC_10	PD_SC_9	PD_SC_8
----------	----------	----------	----------	----------	----------	---------	---------

**Table 464. PEDO\_SC\_DELTAT\_H/L register description**

PD_SC_[15:0]	Time period value (1LSB = 6.4 ms)
--------------	-----------------------------------

**15.2.8 MLC\_EXT\_SENSITIVITY\_L (E8h) and MLC\_EXT\_SENSITIVITY\_H (E9h)**

External sensor sensitivity value register for the machine learning core (R/W)

This register corresponds to the conversion value of the external sensor. The register value is expressed as half-precision floating-point format: SEEEEEEEEEEEE (S: 1 sign bit; E: 5 exponent bits; F: 10 fraction bits).

Default value of MLC\_EXT\_S\_[15:0] is 0x3C00 (when using an external magnetometer this value corresponds to 1 gauss/LSB).

**Table 465. MLC\_EXT\_SENSITIVITY\_L register**

MLC_EXT_S_7	MLC_EXT_S_6	MLC_EXT_S_5	MLC_EXT_S_4	MLC_EXT_S_3	MLC_EXT_S_2	MLC_EXT_S_1	MLC_EXT_S_0
-------------	-------------	-------------	-------------	-------------	-------------	-------------	-------------

**Table 466. MLC\_EXT\_SENSITIVITY\_L register description**

MLC_EXT_S_[7:0]	External sensor sensitivity (LSbyte). Default value: 00000000
-----------------	---

**Table 467. MLC\_EXT\_SENSITIVITY\_H register**

MLC_EXT_S_15	MLC_EXT_S_14	MLC_EXT_S_13	MLC_EXT_S_12	MLC_EXT_S_11	MLC_EXT_S_10	MLC_EXT_S_9	MLC_EXT_S_8
--------------	--------------	--------------	--------------	--------------	--------------	-------------	-------------

**Table 468. MLC\_EXT\_SENSITIVITY\_H register description**

MLC_EXT_S_[15:8]	External sensor sensitivity (MSbyte). Default value: 00111100
------------------	---

## 15.3 Page 2 - embedded advanced features registers

### 15.3.1 EXT\_FORMAT (00h)

External sensor data format (2-byte or 3-byte) for the finite state machine and machine learning core (R/W)

**Table 469. EXT\_FORMAT register**

0 <sup>(1)</sup>	0 <sup>(1)</sup>	0 <sup>(1)</sup>	0 <sup>(1)</sup>	0 <sup>(1)</sup>	0 <sup>(1)</sup>	EXT_FORMAT_SEL	0 <sup>(1)</sup>
------------------	------------------	------------------	------------------	------------------	------------------	----------------	------------------

1. This bit must be set to 0 for the correct operation of the device.

**Table 470. EXT\_FORMAT register description**

EXT_FORMAT_SEL	Selects the format of the external sensor data for FSM and MLC processing. Default value: 0 (0: 2-byte format; 1: 3-byte format)
----------------	--

### 15.3.2 EXT\_3BYTE\_SENSITIVITY\_L (02h) and EXT\_3BYTE\_SENSITIVITY\_H (03h)

External sensor (3-byte output data) sensitivity value register for the finite state machine and machine learning core (R/W)

This register corresponds to the conversion value of the external sensor having 3-byte output data. The register value is expressed as half-precision floating-point format: S EEEEEEEEEEEEEEE (S: 1 sign bit; E: 5 exponent bits; F: 10 fraction bits).

The default value of EXT\_3BYTE\_S\_[15:0] is 0x0C00 (when using an external pressure sensor this value corresponds to 2.441e-04 hPa/LSB).

**Table 471. EXT\_3BYTE\_SENSITIVITY\_L register**

EXT_3BYTE_S_7	EXT_3BYTE_S_6	EXT_3BYTE_S_5	EXT_3BYTE_S_4	EXT_3BYTE_S_3	EXT_3BYTE_S_2	EXT_3BYTE_S_1	EXT_3BYTE_S_0
---------------	---------------	---------------	---------------	---------------	---------------	---------------	---------------

**Table 472. EXT\_3BYTE\_SENSITIVITY\_L register description**

EXT_3BYTE_S_[7:0]	External sensor (3-byte output data) sensitivity (LSbyte). Default value: 00000000
-------------------	--

**Table 473. EXT\_3BYTE\_SENSITIVITY\_H register**

EXT_3BYTE_S_15	EXT_3BYTE_S_14	EXT_3BYTE_S_13	EXT_3BYTE_S_12	EXT_3BYTE_S_11	EXT_3BYTE_S_10	EXT_3BYTE_S_9	EXT_3BYTE_S_8
----------------	----------------	----------------	----------------	----------------	----------------	---------------	---------------

**Table 474. EXT\_3BYTE\_SENSITIVITY\_H register description**

EXT_3BYTE_S_[15:8]	External sensor (3-byte output data) sensitivity (MSbyte). Default value: 00001100
--------------------	--

### 15.3.3 EXT\_3BYTE\_OFFSET\_XL (06h), EXT\_3BYTE\_OFFSET\_L (07h) and EXT\_3BYTE\_OFFSET\_H (08h)

External sensor (3-byte output data) offset value register for the finite state machine and machine learning core (R/W)

This register corresponds to the offset value applied to external sensor output data (3-byte) before being processed in FSM and MLC. The value is expressed as a 24-bit word in two's complement.

The default value of EXT\_3BYTE\_OFF\_[23:0] is 0x3F5400, which corresponds to 4150272 LSB. This offset is subtracted from the external output data (in LSB) before the sensitivity (configured in the EXT\_3BYTE\_SENSITIVITY\_L (02h) and EXT\_3BYTE\_SENSITIVITY\_H (03h) registers) is internally applied.

**Table 475. EXT\_3BYTE\_OFFSET\_XL register**

EXT_3BYTE_OFF_7	EXT_3BYTE_OFF_6	EXT_3BYTE_OFF_5	EXT_3BYTE_OFF_4	EXT_3BYTE_OFF_3	EXT_3BYTE_OFF_2	EXT_3BYTE_OFF_1	EXT_3BYTE_OFF_0
-----------------	-----------------	-----------------	-----------------	-----------------	-----------------	-----------------	-----------------

**Table 476. EXT\_3BYTE\_OFFSET\_XL register description**

EXT_3BYTE_OFF_[7:0]	External sensor (3-byte output data) offset (low byte). Default value: 00000000
---------------------	---

**Table 477. EXT\_3BYTE\_OFFSET\_L register**

EXT_3BYTE_OFF_15	EXT_3BYTE_OFF_14	EXT_3BYTE_OFF_13	EXT_3BYTE_OFF_12	EXT_3BYTE_OFF_11	EXT_3BYTE_OFF_10	EXT_3BYTE_OFF_9	EXT_3BYTE_OFF_8
------------------	------------------	------------------	------------------	------------------	------------------	-----------------	-----------------

**Table 478. EXT\_3BYTE\_OFFSET\_L register description**

EXT_3BYTE_OFF_[15:8]	External sensor (3-byte output data) offset (mid byte). Default value: 01010100
----------------------	---

**Table 479. EXT\_3BYTE\_OFFSET\_H register**

EXT_3BYTE_OFF_23	EXT_3BYTE_OFF_22	EXT_3BYTE_OFF_21	EXT_3BYTE_OFF_20	EXT_3BYTE_OFF_19	EXT_3BYTE_OFF_18	EXT_3BYTE_OFF_17	EXT_3BYTE_OFF_16
------------------	------------------	------------------	------------------	------------------	------------------	------------------	------------------

**Table 480. EXT\_3BYTE\_OFFSET\_H register description**

EXT_3BYTE_OFF_[23:16]	External sensor (3-byte output data) offset (high byte). Default value: 00111111
-----------------------	--

## 16 Sensor hub register mapping

The table given below provides a list of the registers for the sensor hub functions available in the device and the corresponding addresses. The sensor hub registers are accessible when bit SHUB\_REG\_ACCESS is set to 1 in FUNC\_CFG\_ACCESS (01h).

**Table 481. Register address map - sensor hub registers**

Name	Type	Register address		Default	Comment
		Hex	Binary		
SENSOR_HUB_1	R	02	00000010	output	
SENSOR_HUB_2	R	03	00000011	output	
SENSOR_HUB_3	R	04	00000100	output	
SENSOR_HUB_4	R	05	00000101	output	
SENSOR_HUB_5	R	06	00000110	output	
SENSOR_HUB_6	R	07	00000111	output	
SENSOR_HUB_7	R	08	00001000	output	
SENSOR_HUB_8	R	09	00001001	output	
SENSOR_HUB_9	R	0A	00001010	output	
SENSOR_HUB_10	R	0B	00001011	output	
SENSOR_HUB_11	R	0C	00001100	output	
SENSOR_HUB_12	R	0D	00001101	output	
SENSOR_HUB_13	R	0E	00001110	output	
SENSOR_HUB_14	R	0F	00001111	output	
SENSOR_HUB_15	R	10	00010000	output	
SENSOR_HUB_16	R	11	00010001	output	
SENSOR_HUB_17	R	12	00010010	output	
SENSOR_HUB_18	R	13	00010011	output	
CONTROLLER_CONFIG	R/W	14	00010100	00000000	
TGT0_ADD	R/W	15	00010101	00000000	
TGT0_SUBADD	R/W	16	00010110	00000000	
TGT0_CONFIG	R/W	17	00010111	10000000	
TGT1_ADD	R/W	18	00011000	00000000	
TGT1_SUBADD	R/W	19	00011001	00000000	
TGT1_CONFIG	R/W	1A	00011010	00010000	
TGT2_ADD	R/W	1B	00011011	00000000	
TGT2_SUBADD	R/W	1C	00011100	00000000	
TGT2_CONFIG	R/W	1D	00011101	00000000	
TGT3_ADD	R/W	1E	00011110	00000000	
TGT3_SUBADD	R/W	1F	00011111	00000000	
TGT3_CONFIG	R/W	20	00100000	00000000	
DATAWRITE_TGT0	R/W	21	00100001	00000000	
STATUS_CONTROLLER	R	22	00100010	output	

Reserved registers must not be changed. Writing to those registers may cause permanent damage to the device. The content of the registers that are loaded at boot should not be changed. They contain the factory calibration values. Their content is automatically restored when the device is powered up.

## 17 Sensor hub register description

### 17.1 SENSOR\_HUB\_1 (02h)

Sensor hub output register (R)

First byte associated to external sensors. The content of the register is consistent with the TGTx\_CONFIG number of read operation configurations (for external sensors from x = 0 to x = 3).

**Table 482. SENSOR\_HUB\_1 register**

Sensor Hub1_7	Sensor Hub1_6	Sensor Hub1_5	Sensor Hub1_4	Sensor Hub1_3	Sensor Hub1_2	Sensor Hub1_1	Sensor Hub1_0
---------------	---------------	---------------	---------------	---------------	---------------	---------------	---------------

**Table 483. SENSOR\_HUB\_1 register description**

SensorHub1_[7:0]	First byte associated to external sensors
------------------	---

### 17.2 SENSOR\_HUB\_2 (03h)

Sensor hub output register (R)

Second byte associated to external sensors. The content of the register is consistent with the TGTx\_CONFIG number of read operation configurations (for external sensors from x = 0 to x = 3).

**Table 484. SENSOR\_HUB\_2 register**

Sensor Hub2_7	Sensor Hub2_6	Sensor Hub2_5	Sensor Hub2_4	Sensor Hub2_3	Sensor Hub2_2	Sensor Hub2_1	Sensor Hub2_0
---------------	---------------	---------------	---------------	---------------	---------------	---------------	---------------

**Table 485. SENSOR\_HUB\_2 register description**

SensorHub2_[7:0]	Second byte associated to external sensors
------------------	--

### 17.3 SENSOR\_HUB\_3 (04h)

Sensor hub output register (R)

Third byte associated to external sensors. The content of the register is consistent with the TGTx\_CONFIG number of read operation configurations (for external sensors from x = 0 to x = 3).

**Table 486. SENSOR\_HUB\_3 register**

Sensor Hub3_7	Sensor Hub3_6	Sensor Hub3_5	Sensor Hub3_4	Sensor Hub3_3	Sensor Hub3_2	Sensor Hub3_1	Sensor Hub3_0
---------------	---------------	---------------	---------------	---------------	---------------	---------------	---------------

**Table 487. SENSOR\_HUB\_3 register description**

SensorHub3_[7:0]	Third byte associated to external sensors
------------------	---

## 17.4 SENSOR\_HUB\_4 (05h)

Sensor hub output register (R)

Fourth byte associated to external sensors. The content of the register is consistent with the TGTx\_CONFIG number of read operation configurations (for external sensors from x = 0 to x = 3).

**Table 488. SENSOR\_HUB\_4 register**

Sensor Hub4_7	Sensor Hub4_6	Sensor Hub4_5	Sensor Hub4_4	Sensor Hub4_3	Sensor Hub4_2	Sensor Hub4_1	Sensor Hub4_0
---------------	---------------	---------------	---------------	---------------	---------------	---------------	---------------

**Table 489. SENSOR\_HUB\_4 register description**

SensorHub4_[7:0]	Fourth byte associated to external sensors
------------------	--

## 17.5 SENSOR\_HUB\_5 (06h)

Sensor hub output register (R)

Fifth byte associated to external sensors. The content of the register is consistent with the TGTx\_CONFIG number of read operation configurations (for external sensors from x = 0 to x = 3).

**Table 490. SENSOR\_HUB\_5 register**

Sensor Hub5_7	Sensor Hub5_6	Sensor Hub5_5	Sensor Hub5_4	Sensor Hub5_3	Sensor Hub5_2	Sensor Hub5_1	Sensor Hub5_0
---------------	---------------	---------------	---------------	---------------	---------------	---------------	---------------

**Table 491. SENSOR\_HUB\_5 register description**

SensorHub5_[7:0]	Fifth byte associated to external sensors
------------------	---

## 17.6 SENSOR\_HUB\_6 (07h)

Sensor hub output register (R)

Sixth byte associated to external sensors. The content of the register is consistent with the TGTx\_CONFIG number of read operation configurations (for external sensors from x = 0 to x = 3).

**Table 492. SENSOR\_HUB\_6 register**

Sensor Hub6_7	Sensor Hub6_6	Sensor Hub6_5	Sensor Hub6_4	Sensor Hub6_3	Sensor Hub6_2	Sensor Hub6_1	Sensor Hub6_0
---------------	---------------	---------------	---------------	---------------	---------------	---------------	---------------

**Table 493. SENSOR\_HUB\_6 register description**

SensorHub6_[7:0]	Sixth byte associated to external sensors
------------------	---

## 17.7 SENSOR\_HUB\_7 (08h)

Sensor hub output register (R)

Seventh byte associated to external sensors. The content of the register is consistent with the TGTx\_CONFIG number of read operation configurations (for external sensors from x = 0 to x = 3).

**Table 494. SENSOR\_HUB\_7 register**

Sensor Hub7_7	Sensor Hub7_6	Sensor Hub7_5	Sensor Hub7_4	Sensor Hub7_3	Sensor Hub7_2	Sensor Hub7_1	Sensor Hub7_0
---------------	---------------	---------------	---------------	---------------	---------------	---------------	---------------

**Table 495. SENSOR\_HUB\_7 register description**

SensorHub7_[7:0]	Seventh byte associated to external sensors
------------------	---

## 17.8 SENSOR\_HUB\_8 (09h)

Sensor hub output register (R)

Eighth byte associated to external sensors. The content of the register is consistent with the TGTx\_CONFIG number of read operation configurations (for external sensors from x = 0 to x = 3).

**Table 496. SENSOR\_HUB\_8 register**

Sensor Hub8_7	Sensor Hub8_6	Sensor Hub8_5	Sensor Hub8_4	Sensor Hub8_3	Sensor Hub8_2	Sensor Hub8_1	Sensor Hub8_0
---------------	---------------	---------------	---------------	---------------	---------------	---------------	---------------

**Table 497. SENSOR\_HUB\_8 register description**

SensorHub8_[7:0]	Eighth byte associated to external sensors
------------------	--

## 17.9 SENSOR\_HUB\_9 (0Ah)

Sensor hub output register (R)

Ninth byte associated to external sensors. The content of the register is consistent with the TGTx\_CONFIG number of read operation configurations (for external sensors from x = 0 to x = 3).

**Table 498. SENSOR\_HUB\_9 register**

Sensor Hub9_7	Sensor Hub9_6	Sensor Hub9_5	Sensor Hub9_4	Sensor Hub9_3	Sensor Hub9_2	Sensor Hub9_1	Sensor Hub9_0
---------------	---------------	---------------	---------------	---------------	---------------	---------------	---------------

**Table 499. SENSOR\_HUB\_9 register description**

SensorHub9_[7:0]	Ninth byte associated to external sensors
------------------	---

### 17.10 SENSOR\_HUB\_10 (0Bh)

Sensor hub output register (R)

Tenth byte associated to external sensors. The content of the register is consistent with the TGTx\_CONFIG number of read operation configurations (for external sensors from x = 0 to x = 3).

**Table 500. SENSOR\_HUB\_10 register**

Sensor Hub10_7	Sensor Hub10_6	Sensor Hub10_5	Sensor Hub10_4	Sensor Hub10_3	Sensor Hub10_2	Sensor Hub10_1	Sensor Hub10_0
----------------	----------------	----------------	----------------	----------------	----------------	----------------	----------------

**Table 501. SENSOR\_HUB\_10 register description**

SensorHub10_[7:0]	Tenth byte associated to external sensors
-------------------	---

### 17.11 SENSOR\_HUB\_11 (0Ch)

Sensor hub output register (R)

Eleventh byte associated to external sensors. The content of the register is consistent with the TGTx\_CONFIG number of read operation configurations (for external sensors from x = 0 to x = 3).

**Table 502. SENSOR\_HUB\_11 register**

Sensor Hub11_7	Sensor Hub11_6	Sensor Hub11_5	Sensor Hub11_4	Sensor Hub11_3	Sensor Hub11_2	Sensor Hub11_1	Sensor Hub11_0
----------------	----------------	----------------	----------------	----------------	----------------	----------------	----------------

**Table 503. SENSOR\_HUB\_11 register description**

SensorHub11_[7:0]	Eleventh byte associated to external sensors
-------------------	--

### 17.12 SENSOR\_HUB\_12 (0Dh)

Sensor hub output register (R)

Twelfth byte associated to external sensors. The content of the register is consistent with the TGTx\_CONFIG number of read operation configurations (for external sensors from x = 0 to x = 3).

**Table 504. SENSOR\_HUB\_12 register**

Sensor Hub12_7	Sensor Hub12_6	Sensor Hub12_5	Sensor Hub12_4	Sensor Hub12_3	Sensor Hub12_2	Sensor Hub12_1	Sensor Hub12_0
----------------	----------------	----------------	----------------	----------------	----------------	----------------	----------------

**Table 505. SENSOR\_HUB\_12 register description**

SensorHub12_[7:0]	Twelfth byte associated to external sensors
-------------------	---

### 17.13 SENSOR\_HUB\_13 (0Eh)

Sensor hub output register (R)

Thirteenth byte associated to external sensors. The content of the register is consistent with the TGTx\_CONFIG number of read operation configurations (for external sensors from x = 0 to x = 3).

**Table 506. SENSOR\_HUB\_13 register**

Sensor Hub13_7	Sensor Hub13_6	Sensor Hub13_5	Sensor Hub13_4	Sensor Hub13_3	Sensor Hub13_2	Sensor Hub13_1	Sensor Hub13_0
----------------	----------------	----------------	----------------	----------------	----------------	----------------	----------------

**Table 507. SENSOR\_HUB\_13 register description**

SensorHub13_[7:0]	Thirteenth byte associated to external sensors
-------------------	--

### 17.14 SENSOR\_HUB\_14 (0Fh)

Sensor hub output register (R)

Fourteenth byte associated to external sensors. The content of the register is consistent with the TGTx\_CONFIG number of read operation configurations (for external sensors from x = 0 to x = 3).

**Table 508. SENSOR\_HUB\_14 register**

Sensor Hub14_7	Sensor Hub14_6	Sensor Hub14_5	Sensor Hub14_4	Sensor Hub14_3	Sensor Hub14_2	Sensor Hub14_1	Sensor Hub14_0
----------------	----------------	----------------	----------------	----------------	----------------	----------------	----------------

**Table 509. SENSOR\_HUB\_14 register description**

SensorHub14_[7:0]	Fourteenth byte associated to external sensors
-------------------	--

### 17.15 SENSOR\_HUB\_15 (10h)

Sensor hub output register (R)

Fifteenth byte associated to external sensors. The content of the register is consistent with the TGTx\_CONFIG number of read operation configurations (for external sensors from x = 0 to x = 3).

**Table 510. SENSOR\_HUB\_15 register**

Sensor Hub15_7	Sensor Hub15_6	Sensor Hub15_5	Sensor Hub15_4	Sensor Hub15_3	Sensor Hub15_2	Sensor Hub15_1	Sensor Hub15_0
----------------	----------------	----------------	----------------	----------------	----------------	----------------	----------------

**Table 511. SENSOR\_HUB\_15 register description**

SensorHub15_[7:0]	Fifteenth byte associated to external sensors
-------------------	---

### 17.16 SENSOR\_HUB\_16 (11h)

Sensor hub output register (R)

Sixteenth byte associated to external sensors. The content of the register is consistent with the TGTx\_CONFIG number of read operation configurations (for external sensors from x = 0 to x = 3).

**Table 512. SENSOR\_HUB\_16 register**

Sensor Hub16_7	Sensor Hub16_6	Sensor Hub16_5	Sensor Hub16_4	Sensor Hub16_3	Sensor Hub16_2	Sensor Hub16_1	Sensor Hub16_0
----------------	----------------	----------------	----------------	----------------	----------------	----------------	----------------

**Table 513. SENSOR\_HUB\_16 register description**

SensorHub16_[7:0]	Sixteenth byte associated to external sensors
-------------------	---

### 17.17 SENSOR\_HUB\_17 (12h)

Sensor hub output register (R)

Seventeenth byte associated to external sensors. The content of the register is consistent with the TGTx\_CONFIG number of read operation configurations (for external sensors from x = 0 to x = 3).

**Table 514. SENSOR\_HUB\_17 register**

Sensor Hub17_7	Sensor Hub17_6	Sensor Hub17_5	Sensor Hub17_4	Sensor Hub17_3	Sensor Hub17_2	Sensor Hub17_1	Sensor Hub17_0
----------------	----------------	----------------	----------------	----------------	----------------	----------------	----------------

**Table 515. SENSOR\_HUB\_17 register description**

SensorHub17_[7:0]	Seventeenth byte associated to external sensors
-------------------	---

### 17.18 SENSOR\_HUB\_18 (13h)

Sensor hub output register (R)

Eighteenth byte associated to external sensors. The content of the register is consistent with the TGTx\_CONFIG number of read operation configurations (for external sensors from x = 0 to x = 3).

**Table 516. SENSOR\_HUB\_17 register**

Sensor Hub18_7	Sensor Hub18_6	Sensor Hub18_5	Sensor Hub18_4	Sensor Hub18_3	Sensor Hub18_2	Sensor Hub18_1	Sensor Hub18_0
----------------	----------------	----------------	----------------	----------------	----------------	----------------	----------------

**Table 517. SENSOR\_HUB\_17 register description**

SensorHub18_[7:0]	Eighteenth byte associated to external sensors
-------------------	--

## 17.19 CONTROLLER\_CONFIG (14h)

Controller configuration register (R/W)

**Table 518. CONTROLLER\_CONFIG register**

RST_CONTROLLER_REGS	WRITE_ONCE	START_CONFIG	PASS_THROUGH_MODE	0 <sup>(1)</sup>	CONTROLLER_ON	AUX_SENS_ON1	AUX_SENS_ON0
---------------------	------------	--------------	-------------------	------------------	---------------	--------------	--------------

1. This bit must be set to 0 for the correct operation of the device.

**Table 519. CONTROLLER\_CONFIG register description**

RST_CONTROLLER_REGS	Resets controller logic and output registers. Must be set to 1 and then set to 0. Default value: 0
WRITE_ONCE	Target 0 write operation is performed only at the first sensor hub cycle. Default value: 0 (0: write operation for each sensor hub cycle; 1: write operation only for the first sensor hub cycle)
START_CONFIG	Sensor hub trigger signal selection. Default value: 0 (0: sensor hub trigger signal is the accelerometer/gyro data-ready; 1: sensor hub trigger signal external from INT2 pin)
PASS_THROUGH_MODE	I <sup>2</sup> C interface pass-through. Default value: 0 (0: pass-through disabled; 1: pass-through enabled, primary I <sup>2</sup> C line is short-circuited with the sensor hub line)
CONTROLLER_ON	Enables sensor hub I <sup>2</sup> C controller. Default: 0 (0: I <sup>2</sup> C controller of sensor hub disabled; 1: I <sup>2</sup> C controller of sensor hub enabled)
AUX_SENS_ON[1:0]	Number of external sensors to be read by the sensor hub. (00: one sensor (default); 01: two sensors; 10: three sensors; 11: four sensors)

## 17.20 TGT0\_ADD (15h)

I<sup>2</sup>C target address of the first external sensor (sensor 0) register (R/W)

**Table 520. TGT0\_ADD register**

target0_add6	target0_add5	target0_add4	target0_add3	target0_add2	target0_add1	target0_add0	rw_0
--------------	--------------	--------------	--------------	--------------	--------------	--------------	------

**Table 521. TGT0\_ADD register description**

target0_add[6:0]	I <sup>2</sup> C target address of sensor 0 that can be read by the sensor hub. Default value: 0000000
rw_0	Read/write operation on sensor 0. Default value: 0 (0: write operation; 1: read operation)

## 17.21 TGT0\_SUBADD (16h)

Address of register on the first external sensor (sensor 0) register (R/W)

**Table 522. TGT0\_SUBADD register**

target0_reg7	target0_reg6	target0_reg5	target0_reg4	target0_reg3	target0_reg2	target0_reg1	target0_reg0
--------------	--------------	--------------	--------------	--------------	--------------	--------------	--------------

**Table 523. TGT0\_SUBADD register description**

target0_reg[7:0]	Address of register on sensor 0 that has to be read/written according to the rw_0 bit value in TGT0_ADD (15h). Default value: 00000000
------------------	--

## 17.22 TGT0\_CONFIG (17h)

First external sensor (sensor 0) configuration and sensor hub settings register (R/W)

**Table 524. TGT0\_CONFIG register**

SHUB_ODR_2	SHUB_ODR_1	SHUB_ODR_0	0 <sup>(1)</sup>	BATCH_EXT_SENS_0_EN	target0_numop2	target0_numop1	target0_numop0
------------	------------	------------	------------------	---------------------	----------------	----------------	----------------

1. This bit must be set to 0 for the correct operation of the device.

**Table 525. TGT0\_CONFIG register description**

SHUB_ODR_2[2:0]	Rate at which the controller communicates. (000: 1.875 Hz; 001: 15 Hz; 010: 30 Hz; 011: 60 Hz; 100: 120 Hz (default); 101: 240 Hz; 110: 480 Hz; 111: reserved)
BATCH_EXT_SENS_0_EN	Enables FIFO data batching of first target. Default value: 0
target0_numop[2:0]	Number of read operations on sensor 0. Default value: 000

### 17.23 TGT1\_ADD (18h)

I<sup>2</sup>C target address of the second external sensor (sensor 1) register (R/W)

**Table 526. TGT1\_ADD register**

target1_add6	target1_add5	target1_add4	target1_add3	target1_add2	target1_add1	target1_add0	r_1
--------------	--------------	--------------	--------------	--------------	--------------	--------------	-----

**Table 527. TGT1\_ADD register description**

target1_add[6:0]	I <sup>2</sup> C target address of sensor 1 that can be read by the sensor hub. Default value: 0000000
r_1	Enables read operation on sensor 1. Default value: 0 (0: read operation disabled; 1: read operation enabled)

### 17.24 TGT1\_SUBADD (19h)

Address of register on the second external sensor (sensor 1) register (R/W)

**Table 528. TGT1\_SUBADD register**

target1_reg7	target1_reg6	target1_reg5	target1_reg4	target1_reg3	target1_reg2	target1_reg1	target1_reg0
--------------	--------------	--------------	--------------	--------------	--------------	--------------	--------------

**Table 529. TGT1\_SUBADD register description**

target1_reg[7:0]	Address of register on sensor 1 that has to be read/written according to the r_1 bit value in TGT1_ADD (18h).
------------------	---

### 17.25 TGT1\_CONFIG (1Ah)

Second external sensor (sensor 2) configuration register (R/W)

**Table 530. TGT1\_CONFIG register**

0 <sup>(1)</sup>	0 <sup>(1)</sup>	0 <sup>(1)</sup>	1 <sup>(2)</sup>	BATCH_EXT_SENS_1_EN	target1_numop2	target1_numop1	target1_numop0
------------------	------------------	------------------	------------------	---------------------	----------------	----------------	----------------

1. This bit must be set to 0 for the correct operation of the device.
2. This bit must be set to 1 for the correct operation of the device.

**Table 531. TGT1\_CONFIG register description**

BATCH_EXT_SENS_1_EN	Enables FIFO data batching of second target. Default value: 0
target1_numop[2:0]	Number of read operations on sensor 2. Default value: 000

## 17.26 TGT2\_ADD (1Bh)

I<sup>2</sup>C target address of the third external sensor (sensor 2) register (R/W)

**Table 532. TGT2\_ADD register**

target2_add6	target2_add5	target2_add4	target2_add3	target2_add2	target2_add1	target2_add0	r_2
--------------	--------------	--------------	--------------	--------------	--------------	--------------	-----

**Table 533. TGT2\_ADD register description**

target2_add[6:0]	I <sup>2</sup> C target address of sensor 2 that can be read by the sensor hub.
r_2	Enables read operation on sensor 2. Default value: 0 (0: read operation disabled; 1: read operation enabled)

## 17.27 TGT2\_SUBADD (1Ch)

Address of register on the third external sensor (sensor 2) register (R/W)

**Table 534. TGT2\_SUBADD register**

target2_reg7	target2_reg6	target2_reg5	target2_reg4	target2_reg3	target2_reg2	target2_reg1	target2_reg0
--------------	--------------	--------------	--------------	--------------	--------------	--------------	--------------

**Table 535. TGT2\_SUBADD register description**

target2_reg[7:0]	Address of register on sensor 2 that has to be read/written according to the r_2 bit value in TGT2_ADD (1Bh).
------------------	---

## 17.28 TGT2\_CONFIG (1Dh)

Third external sensor (sensor 2) configuration register (R/W)

**Table 536. TGT2\_CONFIG register**

0 <sup>(1)</sup>	0 <sup>(1)</sup>	0 <sup>(1)</sup>	0 <sup>(1)</sup>	BATCH_EXT_SENS_2_EN	target2_numop2	target2_numop1	target2_numop0
------------------	------------------	------------------	------------------	---------------------	----------------	----------------	----------------

1. This bit must be set to 0 for the correct operation of the device.

**Table 537. TGT2\_CONFIG register description**

BATCH_EXT_SENS_2_EN	Enables FIFO data batching of third target. Default value: 0
target2_numop[2:0]	Number of read operations on sensor 2. Default value: 000

### 17.29 TGT3\_ADD (1Eh)

I<sup>2</sup>C target address of the fourth external sensor (sensor 3) register (R/W)

**Table 538. TGT3\_ADD register**

target3_add6	target3_add5	target3_add4	target3_add3	target3_add2	target3_add1	target3_add0	r_3
--------------	--------------	--------------	--------------	--------------	--------------	--------------	-----

**Table 539. TGT3\_ADD register description**

target3_add[6:0]	I <sup>2</sup> C target address of sensor 3 that can be read by the sensor hub.
r_3	Enables read operation on sensor 3. Default value: 0 (0: read operation disabled; 1: read operation enabled)

### 17.30 TGT3\_SUBADD (1Fh)

Address of register on the fourth external sensor (sensor 3) register (R/W)

**Table 540. TGT3\_SUBADD register**

target3_reg7	target3_reg6	target3_reg5	target3_reg4	target3_reg3	target3_reg2	target3_reg1	target3_reg0
--------------	--------------	--------------	--------------	--------------	--------------	--------------	--------------

**Table 541. TGT3\_SUBADD register description**

target3_reg[7:0]	Address of register on sensor 3 that has to be read according to the r_3 bit value in TGT3_ADD (1Eh).
------------------	---

### 17.31 TGT3\_CONFIG (20h)

Fourth external sensor (sensor 3) configuration register (R/W)

**Table 542. TGT3\_CONFIG register**

0 <sup>(1)</sup>	0 <sup>(1)</sup>	0 <sup>(1)</sup>	0 <sup>(1)</sup>	BATCH_EXT_SENS_3_EN	target3_numop2	target3_numop1	target3_numop0
------------------	------------------	------------------	------------------	---------------------	----------------	----------------	----------------

1. This bit must be set to 0 for the correct operation of the device.

**Table 543. TGT3\_CONFIG register description**

BATCH_EXT_SENS_3_EN	Enables FIFO data batching of fourth target. Default value: 0
target3_numop[2:0]	Number of read operations on sensor 3. Default value: 000

### 17.32 DATAWRITE\_TGT0 (21h)

Data to be written into the target device (R/W)

**Table 544. DATAWRITE\_TGT0 register**

target0_ dataw7	target0_ dataw6	target0_ dataw5	target0_ dataw4	target0_ dataw3	target0_ dataw2	target0_ dataw1	target0_ dataw0
--------------------	--------------------	--------------------	--------------------	--------------------	--------------------	--------------------	--------------------

**Table 545. DATAWRITE\_TGT0 register description**

target0_dataw[7:0]	Data to be written into the target 0 device according to the rw_0 bit in register <a href="#">TGT0_ADD (15h)</a> . Default value: 00000000
--------------------	---

### 17.33 STATUS\_CONTROLLER (22h)

Sensor hub source register (R)

**Table 546. STATUS\_CONTROLLER register**

WR_ONCE_ _DONE	TARGET3_ NACK	TARGET2_ NACK	TARGET1_ NACK	TARGET0_ NACK	0	0	SENS_HUB_ _ENDOP
-------------------	------------------	------------------	------------------	------------------	---	---	---------------------

**Table 547. STATUS\_CONTROLLER register description**

WR_ONCE_DONE	When the bit WRITE_ONCE in <a href="#">CONTROLLER_CONFIG (14h)</a> is configured as 1, this bit is set to 1 when the write operation on target 0 has been performed and completed. Default value: 0
TARGET3_NACK	This bit is set to 1 if not acknowledge occurs on target 3 communication. Default value: 0
TARGET2_NACK	This bit is set to 1 if not acknowledge occurs on target 2 communication. Default value: 0
TARGET1_NACK	This bit is set to 1 if not acknowledge occurs on target 1 communication. Default value: 0
TARGET0_NACK	This bit is set to 1 if not acknowledge occurs on target 0 communication. Default value: 0
SENS_HUB_ENDOP	Sensor hub communication status. Default value: 0 (0: sensor hub communication not concluded; 1: sensor hub communication concluded)

## 18 Soldering information

---

The LGA package is compliant with the [ECOPACK](#) and RoHS standard.

It is qualified for soldering heat resistance according to JEDEC J-STD-020.

For land pattern and soldering recommendations, consult technical note [TN0018](#) available on [www.st.com](http://www.st.com).

## 19 Package information

To meet environmental requirements, ST offers these devices in different grades of ECOPACK packages, depending on their level of environmental compliance. ECOPACK specifications, grade definitions, and product status are available at: [www.st.com](http://www.st.com). ECOPACK is an ST trademark.

### 19.1 LGA-14L package information

Figure 32. LGA-14L 2.5 x 3.0 x 0.83 mm package outline and mechanical data

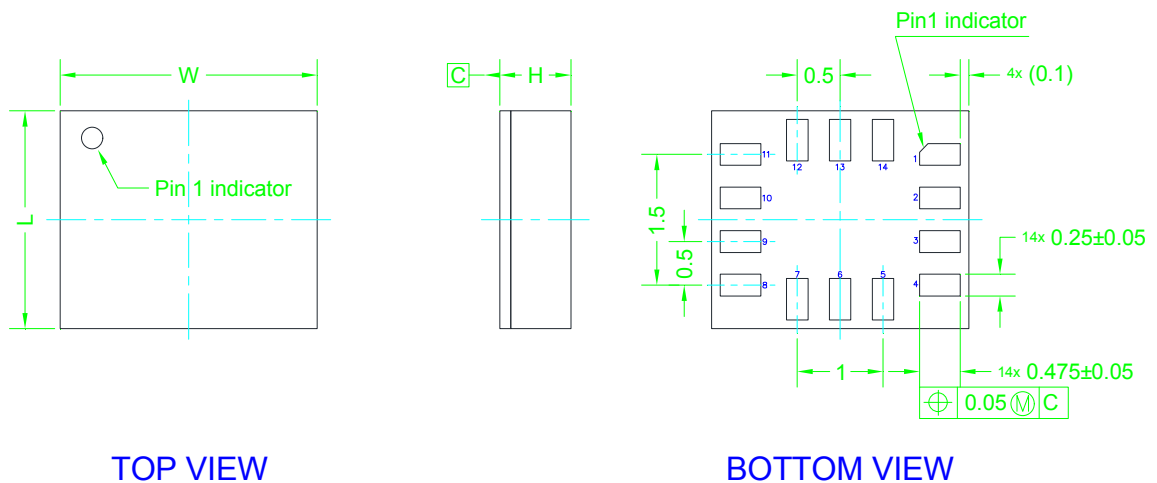

TOP VIEW

BOTTOM VIEW

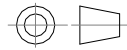

Dimensions are in millimeters unless otherwise specified.  
General tolerance is  $\pm 0.1$  mm unless otherwise specified.

#### OUTER DIMENSIONS

ITEM	DIMENSION [mm]	TOLERANCE [mm]
Length [L]	2.50	$\pm 0.05$
Width [W]	3.00	$\pm 0.05$
Height [H]	0.83	$\pm 0.03$

DM01021587\_2

## 19.2 LGA-14L packing information

Figure 33. Carrier tape information for LGA-14L package

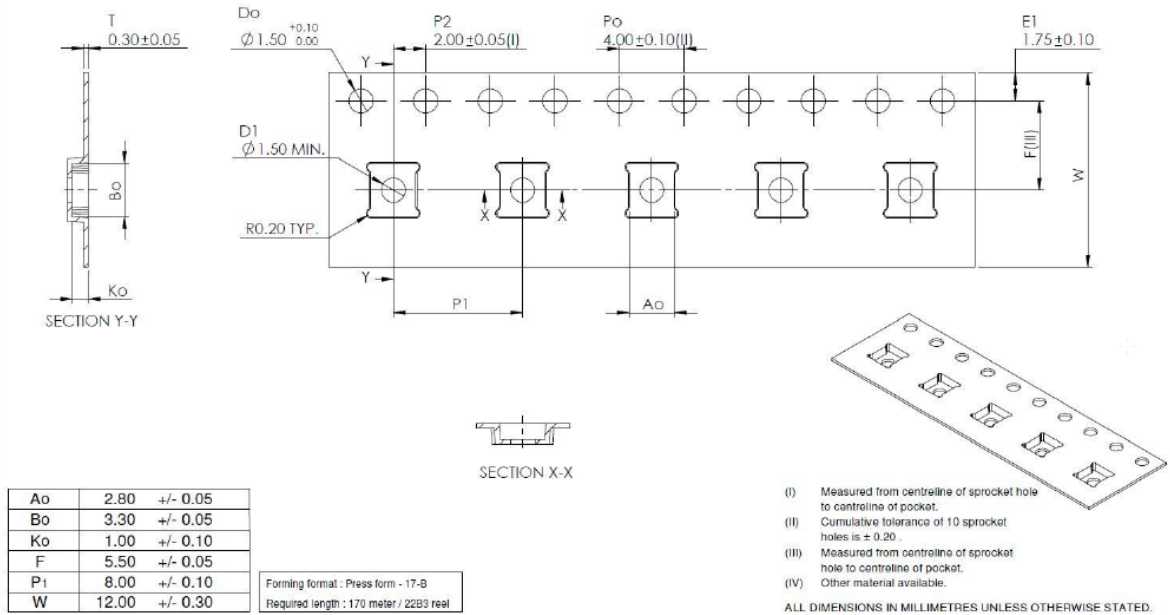

Figure 34. LGA-14L package orientation in carrier tape

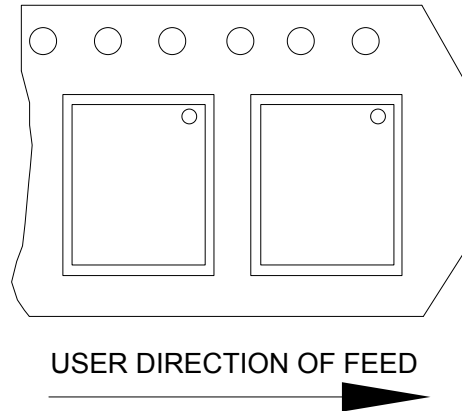

Figure 35. Reel information for carrier tape of LGA-14L package

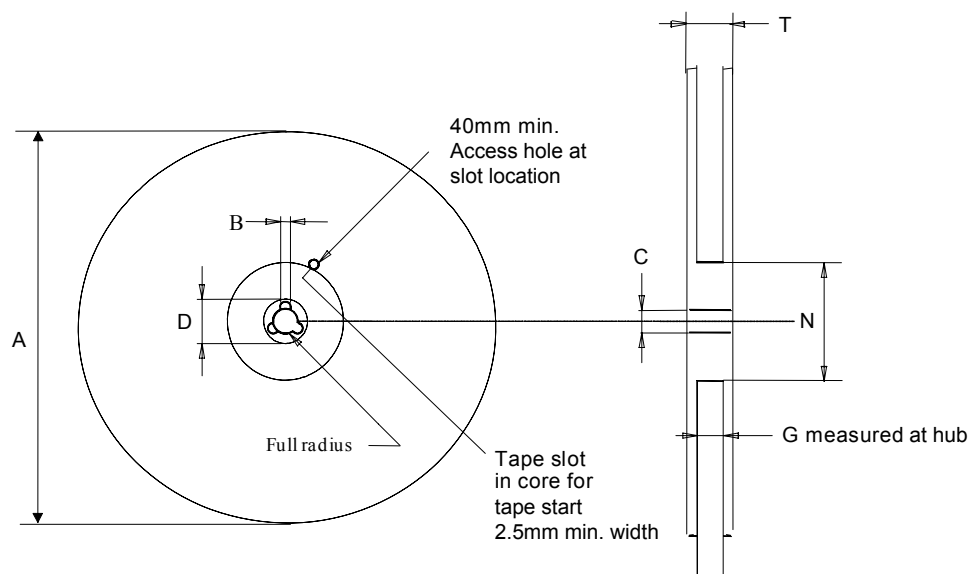

Table 548. Reel dimensions for carrier tape of LGA-14L package

Reel dimensions (mm)	
A (max)	330
B (min)	1.5
C	13 ±0.25
D (min)	20.2
N (min)	60
G	12.4 +2/-0
T (max)	18.4

## Revision history

**Table 549. Document revision history**

Date	Revision	Changes
03-Sep-2025	1	Initial release
01-Oct-2025	2	Updated footnote <sup>(17)</sup> in Table 3. Mechanical characteristics Updated XL_HG_SENSITIVITY_L (58h) and XL_HG_SENSITIVITY_H (59h)

## Contents

<b>1</b>	<b>Overview</b>	<b>3</b>
<b>2</b>	<b>Embedded low-power features</b>	<b>4</b>
2.1	Finite state machine	5
2.2	Machine learning core	6
2.3	Adaptive self-configuration (ASC)	6
2.4	Sensor fusion low power	7
2.5	Pedometer functions: step detector and step counters	7
2.6	Pedometer algorithm	8
2.7	Tilt detection	8
2.8	Significant motion detection	8
<b>3</b>	<b>Pin description</b>	<b>9</b>
3.1	Pin connections	10
<b>4</b>	<b>Module specifications</b>	<b>12</b>
4.1	Mechanical characteristics	12
4.2	Electrical characteristics	15
4.3	Temperature sensor characteristics	16
4.4	Communication interface characteristics	17
4.4.1	SPI - serial peripheral interface	17
4.4.2	I <sup>2</sup> C - inter-IC control interface	19
4.5	Absolute maximum ratings	20
4.6	Terminology	21
4.6.1	Sensitivity	21
4.6.2	Zero-g and zero-rate level	21
<b>5</b>	<b>Digital interfaces</b>	<b>22</b>
5.1	I <sup>2</sup> C/SPI interface	22
5.1.1	I <sup>2</sup> C serial interface	22
5.1.2	I <sup>2</sup> C operation	23
5.1.3	SPI bus interface	25
5.2	MIPI I3C <sup>®</sup> interface	28
5.2.1	MIPI I3C <sup>®</sup> target interface	28
5.2.2	MIPI I3C <sup>®</sup> CCC supported commands	28
5.2.3	Overview of antispikes filter management	29
5.3	Auxiliary MIPI I3C <sup>®</sup> target interface	30
5.4	Auxiliary SPI interface	32

5.5	I <sup>2</sup> C controller interface .....	32
<b>6</b>	<b>Functionality .....</b>	<b>33</b>
6.1	Operating modes .....	33
6.2	Low-g accelerometer .....	33
6.3	High-g accelerometer .....	34
6.4	Gyroscope power modes .....	35
6.5	High-accuracy ODR mode .....	35
6.6	ODR-triggered mode .....	36
6.7	Block diagram of filters .....	37
6.7.1	Block diagrams of the low-g accelerometer filters .....	38
6.7.2	Block diagrams of the gyroscope filters .....	40
6.8	Enhanced EIS .....	42
6.9	OIS .....	43
6.9.1	Enabling OIS functionality and configuration options .....	43
6.10	FIFO .....	46
6.10.1	Bypass mode .....	46
6.10.2	FIFO mode .....	47
6.10.3	Continuous mode .....	47
6.10.4	Continuous-to-FIFO mode .....	47
6.10.5	ContinuousWTM-to-full mode .....	47
6.10.6	Bypass-to-continuous mode .....	48
6.10.7	Bypass-to-FIFO mode .....	48
6.10.8	FIFO reading procedure .....	48
<b>7</b>	<b>Application hints .....</b>	<b>49</b>
7.1	ISM6HG256X electrical connections in mode 1 .....	49
7.2	ISM6HG256X electrical connections in mode 2 .....	50
7.3	ISM6HG256X electrical connections in mode 3 .....	51
<b>8</b>	<b>Register mapping .....</b>	<b>54</b>
<b>9</b>	<b>Register description .....</b>	<b>58</b>
9.1	FUNC_CFG_ACCESS (01h) .....	58
9.2	PIN_CTRL (02h) .....	59
9.3	IF_CFG (03h) .....	60
9.4	ODR_TRIG_CFG (06h) .....	60
9.5	FIFO_CTRL1 (07h) .....	61
9.6	FIFO_CTRL2 (08h) .....	61
9.7	FIFO_CTRL3 (09h) .....	62

<b>9.8</b>	FIFO_CTRL4 (0Ah) .....	63
<b>9.9</b>	COUNTER_BDR_REG1 (0Bh) .....	64
<b>9.10</b>	COUNTER_BDR_REG2 (0Ch) .....	64
<b>9.11</b>	INT1_CTRL (0Dh) .....	65
<b>9.12</b>	INT2_CTRL (0Eh) .....	66
<b>9.13</b>	WHO_AM_I (0Fh) .....	66
<b>9.14</b>	CTRL1 (10h) .....	67
<b>9.15</b>	CTRL2 (11h) .....	68
<b>9.16</b>	CTRL3 (12h) .....	69
<b>9.17</b>	CTRL4 (13h) .....	70
<b>9.18</b>	CTRL5 (14h) .....	71
<b>9.19</b>	CTRL6 (15h) .....	71
<b>9.20</b>	CTRL7 (16h) .....	72
<b>9.21</b>	CTRL8 (17h) .....	73
<b>9.22</b>	CTRL9 (18h) .....	74
<b>9.23</b>	CTRL10 (19h) .....	76
<b>9.24</b>	CTRL_STATUS (1Ah) .....	76
<b>9.25</b>	FIFO_STATUS1 (1Bh) .....	77
<b>9.26</b>	FIFO_STATUS2 (1Ch) .....	77
<b>9.27</b>	ALL_INT_SRC (1Dh) .....	78
<b>9.28</b>	STATUS_REG (1Eh) .....	79
<b>9.29</b>	OUT_TEMP_L (20h), OUT_TEMP_H (21h) .....	80
<b>9.30</b>	OUTX_L_G (22h) and OUTX_H_G (23h) .....	80
<b>9.31</b>	OUTY_L_G (24h) and OUTY_H_G (25h) .....	81
<b>9.32</b>	OUTZ_L_G (26h) and OUTZ_H_G (27h) .....	81
<b>9.33</b>	OUTX_L_A (28h) and OUTX_H_A (29h) .....	82
<b>9.34</b>	OUTY_L_A (2Ah) and OUTY_H_A (2Bh) .....	82
<b>9.35</b>	OUTZ_L_A (2Ch) and OUTZ_H_A (2Dh) .....	83
<b>9.36</b>	UI_OUTX_L_G_OIS_EIS (2Eh) and UI_OUTX_H_G_OIS_EIS (2Fh) .....	83
<b>9.37</b>	UI_OUTY_L_G_OIS_EIS (30h) and UI_OUTY_H_G_OIS_EIS (31h) .....	84
<b>9.38</b>	UI_OUTZ_L_G_OIS_EIS (32h) and UI_OUTZ_H_G_OIS_EIS (33h) .....	84
<b>9.39</b>	UI_OUTX_L_A_OIS_HG (34h) and UI_OUTX_H_A_OIS_HG (35h) .....	85
<b>9.40</b>	UI_OUTY_L_A_OIS_HG (36h) and UI_OUTY_H_A_OIS_HG (37h) .....	85
<b>9.41</b>	UI_OUTZ_L_A_OIS_HG (38h) and UI_OUTZ_H_A_OIS_HG (39h) .....	86
<b>9.42</b>	TIMESTAMP0 (40h), TIMESTAMP1 (41h), TIMESTAMP2 (42h), and TIMESTAMP3 (43h)	87
<b>9.43</b>	UI_STATUS_REG_OIS (44h) .....	87

<b>9.44</b>	WAKE_UP_SRC (45h) .....	88
<b>9.45</b>	TAP_SRC (46h) .....	89
<b>9.46</b>	D6D_SRC (47h) .....	90
<b>9.47</b>	STATUS_CONTROLLER_MAINPAGE (48h) .....	90
<b>9.48</b>	EMB_FUNC_STATUS_MAINPAGE (49h) .....	91
<b>9.49</b>	FSM_STATUS_MAINPAGE (4Ah) .....	91
<b>9.50</b>	MLC_STATUS_MAINPAGE (4Bh) .....	92
<b>9.51</b>	HG_WAKE_UP_SRC (4Ch) .....	92
<b>9.52</b>	CTRL2_XL_HG (4Dh) .....	93
<b>9.53</b>	CTRL1_XL_HG (4Eh) .....	93
<b>9.54</b>	INTERNAL_FREQ_FINE (4Fh) .....	94
<b>9.55</b>	FUNCTIONS_ENABLE (50h) .....	95
<b>9.56</b>	HG_FUNCTIONS_ENABLE (52h) .....	96
<b>9.57</b>	HG_WAKE_UP_THS (53h) .....	96
<b>9.58</b>	INACTIVITY_DUR (54h) .....	97
<b>9.59</b>	INACTIVITY_THS (55h) .....	98
<b>9.60</b>	TAP_CFG0 (56h) .....	99
<b>9.61</b>	TAP_CFG1 (57h) .....	100
<b>9.62</b>	TAP_CFG2 (58h) .....	100
<b>9.63</b>	TAP_THS_6D (59h) .....	101
<b>9.64</b>	TAP_DUR (5Ah) .....	102
<b>9.65</b>	WAKE_UP_THS (5Bh) .....	102
<b>9.66</b>	WAKE_UP_DUR (5Ch) .....	103
<b>9.67</b>	FREE_FALL (5Dh) .....	103
<b>9.68</b>	MD1_CFG (5Eh) .....	104
<b>9.69</b>	MD2_CFG (5Fh) .....	105
<b>9.70</b>	HAODR_CFG (62h) .....	105
<b>9.71</b>	EMB_FUNC_CFG (63h) .....	106
<b>9.72</b>	UI_HANDSHAKE_CTRL (64h) .....	106
<b>9.73</b>	UI_IF2_SHARED_0 (65h) .....	107
<b>9.74</b>	UI_IF2_SHARED_1 (66h) .....	107
<b>9.75</b>	UI_IF2_SHARED_2 (67h) .....	107
<b>9.76</b>	UI_IF2_SHARED_3 (68h) .....	108
<b>9.77</b>	UI_IF2_SHARED_4 (69h) .....	108
<b>9.78</b>	UI_IF2_SHARED_5 (6Ah) .....	108
<b>9.79</b>	CTRL_EIS (6Bh) .....	109

9.80	XL_HG_X_OFS_USR (6Ch) .....	110
9.81	XL_HG_Y_OFS_USR (6Dh) .....	110
9.82	XL_HG_Z_OFS_USR (6Eh) .....	110
9.83	UI_INT_OIS (6Fh) .....	111
9.84	UI_CTRL1_OIS (70h) .....	112
9.85	UI_CTRL2_OIS (71h) .....	113
9.86	UI_CTRL3_OIS (72h) .....	114
9.87	X_OFS_USR (73h) .....	115
9.88	Y_OFS_USR (74h) .....	115
9.89	Z_OFS_USR (75h) .....	115
9.90	FIFO_DATA_OUT_TAG (78h) .....	116
9.91	FIFO_DATA_OUT_X_L (79h) and FIFO_DATA_OUT_X_H (7Ah) .....	117
9.92	FIFO_DATA_OUT_Y_L (7Bh) and FIFO_DATA_OUT_Y_H (7Ch) .....	117
9.93	FIFO_DATA_OUT_Z_L (7Dh) and FIFO_DATA_OUT_Z_H (7Eh) .....	117
<b>10</b>	<b>IF2 register mapping .....</b>	<b>118</b>
<b>11</b>	<b>IF2 register description .....</b>	<b>119</b>
11.1	IF2_WHO_AM_I (0Fh) .....	119
11.2	IF2_STATUS_REG_OIS (1Eh) .....	119
11.3	IF2_OUT_TEMP_L (20h) and IF2_OUT_TEMP_H (21h) .....	119
11.4	IF2_OUTX_L_G_OIS (22h) and IF2_OUTX_H_G_OIS (23h) .....	120
11.5	IF2_OUTY_L_G_OIS (24h) and IF2_OUTY_H_G_OIS (25h) .....	120
11.6	IF2_OUTZ_L_G_OIS (26h) and IF2_OUTZ_H_G_OIS (27h) .....	121
11.7	IF2_OUTX_L_A_OIS (28h) and IF2_OUTX_H_A_OIS (29h) .....	121
11.8	IF2_OUTY_L_A_OIS (2Ah) and IF2_OUTY_H_A_OIS (2Bh) .....	122
11.9	IF2_OUTZ_L_A_OIS (2Ch) and IF2_OUTZ_H_A_OIS (2Dh) .....	122
11.10	IF2_HANDSHAKE_CTRL (6Eh) .....	122
11.11	IF2_INT_OIS (6Fh) .....	123
11.12	IF2_CTRL1_OIS (70h) .....	124
11.13	IF2_CTRL2_OIS (71h) .....	125
11.14	IF2_CTRL3_OIS (72h) .....	126
<b>12</b>	<b>Embedded functions register mapping .....</b>	<b>127</b>
<b>13</b>	<b>Embedded functions register description .....</b>	<b>130</b>
13.1	PAGE_SEL (02h) .....	130
13.2	EMB_FUNC_EN_A (04h) .....	130
13.3	EMB_FUNC_EN_B (05h) .....	131

<b>13.4</b>	<b>EMB_FUNC_EXEC_STATUS (07h)</b> .....	<b>131</b>
<b>13.5</b>	<b>PAGE_ADDRESS (08h)</b> .....	<b>132</b>
<b>13.6</b>	<b>PAGE_VALUE (09h)</b> .....	<b>132</b>
<b>13.7</b>	<b>EMB_FUNC_INT1 (0Ah)</b> .....	<b>132</b>
<b>13.8</b>	<b>FSM_INT1 (0Bh)</b> .....	<b>133</b>
<b>13.9</b>	<b>MLC_INT1 (0Dh)</b> .....	<b>134</b>
<b>13.10</b>	<b>EMB_FUNC_INT2 (0Eh)</b> .....	<b>134</b>
<b>13.11</b>	<b>FSM_INT2 (0Fh)</b> .....	<b>135</b>
<b>13.12</b>	<b>MLC_INT2 (11h)</b> .....	<b>136</b>
<b>13.13</b>	<b>EMB_FUNC_STATUS (12h)</b> .....	<b>136</b>
<b>13.14</b>	<b>FSM_STATUS (13h)</b> .....	<b>137</b>
<b>13.15</b>	<b>MLC_STATUS (15h)</b> .....	<b>137</b>
<b>13.16</b>	<b>PAGE_RW (17h)</b> .....	<b>138</b>
<b>13.17</b>	<b>SFLP_GBIASX_L (18h) and SFLP_GBIASX_H (19h)</b> .....	<b>139</b>
<b>13.18</b>	<b>SFLP_GBIASY_L (1Ah) and SFLP_GBIASY_H (1Bh)</b> .....	<b>139</b>
<b>13.19</b>	<b>SFLP_GBIASZ_L (1Ch) and SFLP_GBIASZ_H (1Dh)</b> .....	<b>139</b>
<b>13.20</b>	<b>SFLP_GRAVX_L (1Eh) and SFLP_GRAVX_H (1Fh)</b> .....	<b>140</b>
<b>13.21</b>	<b>SFLP_GRAVY_L (20h) and SFLP_GRAVY_H (21h)</b> .....	<b>140</b>
<b>13.22</b>	<b>SFLP_GRAVZ_L (22h) and SFLP_GRAVY_H (23h)</b> .....	<b>140</b>
<b>13.23</b>	<b>SFLP_QUATW_L (2Ah) and SFLP_QUATW_H (2Bh)</b> .....	<b>141</b>
<b>13.24</b>	<b>SFLP_QUATX_L (2Ch) and SFLP_QUATX_H (2Dh)</b> .....	<b>141</b>
<b>13.25</b>	<b>SFLP_QUATY_L (2Eh) and SFLP_QUATY_H (2Fh)</b> .....	<b>141</b>
<b>13.26</b>	<b>SFLP_QUATZ_L (30h) and SFLP_QUATZ_H (31h)</b> .....	<b>142</b>
<b>13.27</b>	<b>SFLP_GBIASX_INIT_L (32h) and SFLP_GBIASX_INIT_H (33h)</b> .....	<b>142</b>
<b>13.28</b>	<b>SFLP_GBIASY_INIT_L (34h) and SFLP_GBIASY_INIT_H (35h)</b> .....	<b>142</b>
<b>13.29</b>	<b>SFLP_GBIASZ_INIT_L (36h) and SFLP_GBIASZ_INIT_H (37h)</b> .....	<b>143</b>
<b>13.30</b>	<b>EMB_FUNC_FIFO_EN_A (44h)</b> .....	<b>143</b>
<b>13.31</b>	<b>EMB_FUNC_FIFO_EN_B (45h)</b> .....	<b>144</b>
<b>13.32</b>	<b>FSM_ENABLE (46h)</b> .....	<b>144</b>
<b>13.33</b>	<b>FSM_LONG_COUNTER_L (48h) and FSM_LONG_COUNTER_H (49h)</b> .....	<b>145</b>
<b>13.34</b>	<b>INT_ACK_MASK (4Bh)</b> .....	<b>146</b>
<b>13.35</b>	<b>FSM_OUTS1 (4Ch)</b> .....	<b>147</b>
<b>13.36</b>	<b>FSM_OUTS2 (4Dh)</b> .....	<b>147</b>
<b>13.37</b>	<b>FSM_OUTS3 (4Eh)</b> .....	<b>148</b>
<b>13.38</b>	<b>FSM_OUTS4 (4Fh)</b> .....	<b>148</b>
<b>13.39</b>	<b>FSM_OUTS5 (50h)</b> .....	<b>149</b>

13.40	FSM_OUTS6 (51h) .....	149
13.41	FSM_OUTS7 (52h) .....	150
13.42	FSM_OUTS8 (53h) .....	150
13.43	SFLP_ODR (5Eh) .....	151
13.44	FSM_ODR (5Fh) .....	151
13.45	MLC_ODR (60h) .....	152
13.46	STEP_COUNTER_L (62h) and STEP_COUNTER_H (63h) .....	152
13.47	EMB_FUNC_SRC (64h) .....	153
13.48	EMB_FUNC_INIT_A (66h) .....	154
13.49	EMB_FUNC_INIT_B (67h) .....	154
13.50	EMB_FUNC_SENSOR_CONV_EN (6Eh) .....	154
13.51	MLC1_SRC (70h) .....	155
13.52	MLC2_SRC (71h) .....	155
13.53	MLC3_SRC (72h) .....	155
13.54	MLC4_SRC (73h) .....	155
13.55	MLC5_SRC (74h) .....	156
13.56	MLC6_SRC (75h) .....	156
13.57	MLC7_SRC (76h) .....	156
13.58	MLC8_SRC (77h) .....	156
<b>14</b>	<b>Embedded advanced features pages .....</b>	<b>157</b>
<b>15</b>	<b>Embedded advanced features register description .....</b>	<b>160</b>
15.1	Page 0 - embedded advanced features registers .....	160
15.1.1	FSM_EXT_SENSITIVITY_L (BAh) and FSM_EXT_SENSITIVITY_H (BBh) .....	160
15.1.2	FSM_EXT_OFFX_L (C0h) and FSM_EXT_OFFX_H (C1h) .....	161
15.1.3	FSM_EXT_OFFY_L (C2h) and FSM_EXT_OFFY_H (C3h) .....	161
15.1.4	FSM_EXT_OFFZ_L (C4h) and FSM_EXT_OFFZ_H (C5h) .....	162
15.1.5	FSM_EXT_MATRIX_XX_L (C6h) and FSM_EXT_MATRIX_XX_H (C7h) .....	162
15.1.6	FSM_EXT_MATRIX_XY_L (C8h) and FSM_EXT_MATRIX_XY_H (C9h) .....	163
15.1.7	FSM_EXT_MATRIX_XZ_L (CAh) and FSM_EXT_MATRIX_XZ_H (CBh) .....	163
15.1.8	FSM_EXT_MATRIX_YY_L (CCh) and FSM_EXT_MATRIX_YY_H (CDh) .....	164
15.1.9	FSM_EXT_MATRIX_YZ_L (CEh) and FSM_EXT_MATRIX_YZ_H (CFh) .....	164
15.1.10	FSM_EXT_MATRIX_ZZ_L (D0h) and FSM_EXT_MATRIX_ZZ_H (D1h) .....	165
15.1.11	EXT_CFG_A (D4h) .....	166
15.1.12	EXT_CFG_B (D5h) .....	166
15.2	Page 1 - embedded advanced features registers .....	167
15.2.1	XL_HG_SENSITIVITY_L (58h) and XL_HG_SENSITIVITY_H (59h) .....	167

15.2.2	FSM_LC_TIMEOUT_L (7Ah) and FSM_LC_TIMEOUT_H (7Bh)	167
15.2.3	FSM_PROGRAMS (7Ch)	168
15.2.4	FSM_START_ADD_L (7Eh) and FSM_START_ADD_H (7Fh)	168
15.2.5	PEDO_CMD_REG (83h)	169
15.2.6	PEDO_DEB_STEPS_CONF (84h)	169
15.2.7	PEDO_SC_DELTAT_L (D0h) and PEDO_SC_DELTAT_H (D1h)	169
15.2.8	MLC_EXT_SENSITIVITY_L (E8h) and MLC_EXT_SENSITIVITY_H (E9h)	170
15.3	Page 2 - embedded advanced features registers	171
15.3.1	EXT_FORMAT (00h)	171
15.3.2	EXT_3BYTE_SENSITIVITY_L (02h) and EXT_3BYTE_SENSITIVITY_H (03h)	171
15.3.3	EXT_3BYTE_OFFSET_XL (06h), EXT_3BYTE_OFFSET_L (07h) and EXT_3BYTE_OFFSET_H (08h)	172
<b>16</b>	<b>Sensor hub register mapping</b>	<b>173</b>
<b>17</b>	<b>Sensor hub register description</b>	<b>174</b>
17.1	SENSOR_HUB_1 (02h)	174
17.2	SENSOR_HUB_2 (03h)	174
17.3	SENSOR_HUB_3 (04h)	174
17.4	SENSOR_HUB_4 (05h)	175
17.5	SENSOR_HUB_5 (06h)	175
17.6	SENSOR_HUB_6 (07h)	175
17.7	SENSOR_HUB_7 (08h)	176
17.8	SENSOR_HUB_8 (09h)	176
17.9	SENSOR_HUB_9 (0Ah)	176
17.10	SENSOR_HUB_10 (0Bh)	177
17.11	SENSOR_HUB_11 (0Ch)	177
17.12	SENSOR_HUB_12 (0Dh)	177
17.13	SENSOR_HUB_13 (0Eh)	178
17.14	SENSOR_HUB_14 (0Fh)	178
17.15	SENSOR_HUB_15 (10h)	178
17.16	SENSOR_HUB_16 (11h)	179
17.17	SENSOR_HUB_17 (12h)	179
17.18	SENSOR_HUB_18 (13h)	179
17.19	CONTROLLER_CONFIG (14h)	180
17.20	TGT0_ADD (15h)	181
17.21	TGT0_SUBADD (16h)	181
17.22	TGT0_CONFIG (17h)	181
17.23	TGT1_ADD (18h)	182

17.24	TGT1_SUBADD (19h)	182
17.25	TGT1_CONFIG (1Ah)	182
17.26	TGT2_ADD (1Bh)	183
17.27	TGT2_SUBADD (1Ch)	183
17.28	TGT2_CONFIG (1Dh)	183
17.29	TGT3_ADD (1Eh)	184
17.30	TGT3_SUBADD (1Fh)	184
17.31	TGT3_CONFIG (20h)	184
17.32	DATAWRITE_TGT0 (21h)	185
17.33	STATUS_CONTROLLER (22h)	185
<b>18</b>	<b>Soldering information</b>	<b>186</b>
<b>19</b>	<b>Package information</b>	<b>187</b>
19.1	LGA-14L package information	187
19.2	LGA-14L packing information	188
	<b>Revision history</b>	<b>190</b>
	<b>List of tables</b>	<b>200</b>
	<b>List of figures</b>	<b>211</b>

## List of tables

<b>Table 1.</b>	Sensor fusion performance . . . . .	7
<b>Table 2.</b>	Pin description . . . . .	11
<b>Table 3.</b>	Mechanical characteristics . . . . .	12
<b>Table 4.</b>	Electrical characteristics . . . . .	15
<b>Table 5.</b>	Temperature sensor characteristics . . . . .	16
<b>Table 6.</b>	SPI target timing values (VDDIO at 1.8 V) . . . . .	17
<b>Table 7.</b>	SPI target timing values (VDDIO at 1.2 V) . . . . .	17
<b>Table 8.</b>	I <sup>2</sup> C target timing values . . . . .	19
<b>Table 9.</b>	Absolute maximum ratings . . . . .	20
<b>Table 10.</b>	Serial interface pin description . . . . .	22
<b>Table 11.</b>	I <sup>2</sup> C terminology . . . . .	22
<b>Table 12.</b>	TAD+read/write patterns . . . . .	23
<b>Table 13.</b>	Transfer when controller is writing one byte to target . . . . .	23
<b>Table 14.</b>	Transfer when controller is writing multiple bytes to target . . . . .	23
<b>Table 15.</b>	Transfer when controller is receiving (reading) one byte of data from target . . . . .	23
<b>Table 16.</b>	Transfer when controller is receiving (reading) multiple bytes of data from target . . . . .	23
<b>Table 17.</b>	MIPI I3C <sup>®</sup> CCC commands . . . . .	28
<b>Table 18.</b>	MIPI I3C <sup>®</sup> CCC commands . . . . .	30
<b>Table 19.</b>	Auxiliary SPI pin details . . . . .	32
<b>Table 20.</b>	I <sup>2</sup> C controller pin details . . . . .	32
<b>Table 21.</b>	High-g accelerometer compatibility with low-g accelerometer operating modes and ODRs . . . . .	34
<b>Table 22.</b>	Accelerometer and gyroscope ODR selection in high-accuracy ODR mode . . . . .	35
<b>Table 23.</b>	Gyroscope LPF2 bandwidth selection . . . . .	40
<b>Table 24.</b>	OIS configurations . . . . .	43
<b>Table 25.</b>	Internal pin status . . . . .	52
<b>Table 26.</b>	Registers address map . . . . .	54
<b>Table 27.</b>	FUNC_CFG_ACCESS register . . . . .	58
<b>Table 28.</b>	FUNC_CFG_ACCESS register description . . . . .	58
<b>Table 29.</b>	PIN_CTRL register . . . . .	59
<b>Table 30.</b>	PIN_CTRL register description . . . . .	59
<b>Table 31.</b>	IF_CFG register . . . . .	60
<b>Table 32.</b>	IF_CFG register description . . . . .	60
<b>Table 33.</b>	ODR_TRIG_CFG register . . . . .	60
<b>Table 34.</b>	ODR_TRIG_CFG register description . . . . .	60
<b>Table 35.</b>	FIFO_CTRL1 register . . . . .	61
<b>Table 36.</b>	FIFO_CTRL1 register description . . . . .	61
<b>Table 37.</b>	FIFO_CTRL2 register . . . . .	61
<b>Table 38.</b>	FIFO_CTRL2 register description . . . . .	61
<b>Table 39.</b>	FIFO_CTRL3 register . . . . .	62
<b>Table 40.</b>	FIFO_CTRL3 register description . . . . .	62
<b>Table 41.</b>	FIFO_CTRL4 register . . . . .	63
<b>Table 42.</b>	FIFO_CTRL4 register description . . . . .	63
<b>Table 43.</b>	COUNTER_BDR_REG1 register . . . . .	64
<b>Table 44.</b>	COUNTER_BDR_REG1 register description . . . . .	64
<b>Table 45.</b>	COUNTER_BDR_REG2 register . . . . .	64
<b>Table 46.</b>	COUNTER_BDR_REG2 register description . . . . .	64
<b>Table 47.</b>	INT1_CTRL register . . . . .	65
<b>Table 48.</b>	INT1_CTRL register description . . . . .	65
<b>Table 49.</b>	INT2_CTRL register . . . . .	66
<b>Table 50.</b>	INT2_CTRL register description . . . . .	66
<b>Table 51.</b>	WhoAml register . . . . .	66
<b>Table 52.</b>	CTRL1 register . . . . .	67
<b>Table 53.</b>	CTRL1 register description . . . . .	67

<b>Table 54.</b>	Accelerometer ODR selection . . . . .	67
<b>Table 55.</b>	CTRL2 register . . . . .	68
<b>Table 56.</b>	CTRL2 register description . . . . .	68
<b>Table 57.</b>	Gyroscope ODR selection . . . . .	68
<b>Table 58.</b>	CTRL3 register . . . . .	69
<b>Table 59.</b>	CTRL3 register description . . . . .	69
<b>Table 60.</b>	CTRL4 register . . . . .	70
<b>Table 61.</b>	CTRL4 register description . . . . .	70
<b>Table 62.</b>	CTRL5 register . . . . .	71
<b>Table 63.</b>	CTRL5 register description . . . . .	71
<b>Table 64.</b>	CTRL6 register . . . . .	71
<b>Table 65.</b>	CTRL6 register description . . . . .	71
<b>Table 66.</b>	Gyroscope LPF1 + LPF2 bandwidth selection . . . . .	72
<b>Table 67.</b>	CTRL7 register . . . . .	72
<b>Table 68.</b>	CTRL7 register description . . . . .	72
<b>Table 69.</b>	CTRL8 register . . . . .	73
<b>Table 70.</b>	CTRL8 register description . . . . .	73
<b>Table 71.</b>	Accelerometer bandwidth configurations . . . . .	73
<b>Table 72.</b>	CTRL9 register . . . . .	74
<b>Table 73.</b>	CTRL9 register description . . . . .	74
<b>Table 74.</b>	CTRL10 register . . . . .	76
<b>Table 75.</b>	CTRL10 register description . . . . .	76
<b>Table 76.</b>	CTRL_STATUS register . . . . .	76
<b>Table 77.</b>	CTRL_STATUS register description . . . . .	76
<b>Table 78.</b>	FIFO_STATUS1 register . . . . .	77
<b>Table 79.</b>	FIFO_STATUS1 register description . . . . .	77
<b>Table 80.</b>	FIFO_STATUS2 register . . . . .	77
<b>Table 81.</b>	FIFO_STATUS2 register description . . . . .	77
<b>Table 82.</b>	ALL_INT_SRC register . . . . .	78
<b>Table 83.</b>	ALL_INT_SRC register description . . . . .	78
<b>Table 84.</b>	STATUS_REG register . . . . .	79
<b>Table 85.</b>	STATUS_REG register description . . . . .	79
<b>Table 86.</b>	OUT_TEMP_L register . . . . .	80
<b>Table 87.</b>	OUT_TEMP_H register . . . . .	80
<b>Table 88.</b>	OUT_TEMP register description . . . . .	80
<b>Table 89.</b>	OUTX_L_G register . . . . .	80
<b>Table 90.</b>	OUTX_H_G register . . . . .	80
<b>Table 91.</b>	OUTX_G register description . . . . .	80
<b>Table 92.</b>	OUTY_L_G register . . . . .	81
<b>Table 93.</b>	OUTY_H_G register . . . . .	81
<b>Table 94.</b>	OUTY_G register description . . . . .	81
<b>Table 95.</b>	OUTZ_L_G register . . . . .	81
<b>Table 96.</b>	OUTZ_H_G register . . . . .	81
<b>Table 97.</b>	OUTZ_H_G register description . . . . .	81
<b>Table 98.</b>	OUTX_L_A register . . . . .	82
<b>Table 99.</b>	OUTX_H_A register . . . . .	82
<b>Table 100.</b>	OUTX_A register description . . . . .	82
<b>Table 101.</b>	OUTY_L_A register . . . . .	82
<b>Table 102.</b>	OUTY_H_A register . . . . .	82
<b>Table 103.</b>	OUTY_A register description . . . . .	82
<b>Table 104.</b>	OUTZ_L_A register . . . . .	83
<b>Table 105.</b>	OUTZ_H_A register . . . . .	83
<b>Table 106.</b>	OUTZ_A register description . . . . .	83
<b>Table 107.</b>	UI_OUTX_L_G_OIS_EIS register . . . . .	83
<b>Table 108.</b>	UI_OUTX_H_G_OIS_EIS register . . . . .	83

<b>Table 109.</b>	UI_OUTX_G_OIS_EIS register description	83
<b>Table 110.</b>	UI_OUTY_L_G_OIS_EIS register	84
<b>Table 111.</b>	UI_OUTY_H_G_OIS_EIS register	84
<b>Table 112.</b>	UI_OUTY_G_OIS_EIS register description	84
<b>Table 113.</b>	UI_OUTZ_L_G_OIS_EIS register	84
<b>Table 114.</b>	UI_OUTZ_H_G_OIS_EIS register	84
<b>Table 115.</b>	UI_OUTZ_G_OIS_EIS register description	84
<b>Table 116.</b>	UI_OUTX_L_A_OIS_HG register	85
<b>Table 117.</b>	UI_OUTX_H_A_OIS_HG register	85
<b>Table 118.</b>	UI_OUTX_A_OIS_HG register description	85
<b>Table 119.</b>	UI_OUTY_L_A_OIS_HG register	85
<b>Table 120.</b>	UI_OUTY_H_A_OIS_HG register	85
<b>Table 121.</b>	UI_OUTY_A_OIS_HG register description	85
<b>Table 122.</b>	UI_OUTZ_L_A_OIS_HG register	86
<b>Table 123.</b>	UI_OUTZ_H_A_OIS_HG register	86
<b>Table 124.</b>	UI_OUTZ_A_OIS_HG register description	86
<b>Table 125.</b>	TIMESTAMP output registers	87
<b>Table 126.</b>	TIMESTAMP output register description	87
<b>Table 127.</b>	UI_STATUS_REG_OIS register	87
<b>Table 128.</b>	UI_STATUS_REG_OIS register description	87
<b>Table 129.</b>	WAKE_UP_SRC register	88
<b>Table 130.</b>	WAKE_UP_SRC register description	88
<b>Table 131.</b>	TAP_SRC register	89
<b>Table 132.</b>	TAP_SRC register description	89
<b>Table 133.</b>	D6D_SRC register	90
<b>Table 134.</b>	D6D_SRC register description	90
<b>Table 135.</b>	STATUS_CONTROLLER_MAINPAGE register	90
<b>Table 136.</b>	STATUS_CONTROLLER_MAINPAGE register description	90
<b>Table 137.</b>	EMB_FUNC_STATUS_MAINPAGE register	91
<b>Table 138.</b>	EMB_FUNC_STATUS_MAINPAGE register description	91
<b>Table 139.</b>	FSM_STATUS_MAINPAGE register	91
<b>Table 140.</b>	FSM_STATUS_MAINPAGE register description	91
<b>Table 141.</b>	MLC_STATUS_MAINPAGE register	92
<b>Table 142.</b>	MLC_STATUS_MAINPAGE register description	92
<b>Table 143.</b>	HG_WAKE_UP_SRC register	92
<b>Table 144.</b>	HG_WAKE_UP_SRC register description	92
<b>Table 145.</b>	CTRL2_XL_HG register	93
<b>Table 146.</b>	CTRL2_XL_HG register description	93
<b>Table 147.</b>	CTRL1_XL_HG register	93
<b>Table 148.</b>	CTRL1_XL_HG register description	93
<b>Table 149.</b>	High-g accelerometer ODR selection	93
<b>Table 150.</b>	High-g accelerometer full-scale selection	93
<b>Table 151.</b>	INTERNAL_FREQ_FINE register	94
<b>Table 152.</b>	INTERNAL_FREQ_FINE register description	94
<b>Table 153.</b>	ODR <sub>coeff</sub> values	94
<b>Table 154.</b>	FUNCTIONS_ENABLE register	95
<b>Table 155.</b>	FUNCTIONS_ENABLE register description	95
<b>Table 156.</b>	HG_FUNCTIONS_ENABLE register	96
<b>Table 157.</b>	HG_FUNCTIONS_ENABLE register description	96
<b>Table 158.</b>	HG_WAKE_UP_THS register	96
<b>Table 159.</b>	HG_WAKE_UP_THS register description	96
<b>Table 160.</b>	INACTIVITY_DUR register	97
<b>Table 161.</b>	INACTIVITY_DUR register description	97
<b>Table 162.</b>	INACTIVITY_THS register	98
<b>Table 163.</b>	INACTIVITY_THS register description	98

<b>Table 164.</b>	TAP_CFG0 register . . . . .	99
<b>Table 165.</b>	TAP_CFG0 register description . . . . .	99
<b>Table 166.</b>	TAP_CFG1 register . . . . .	100
<b>Table 167.</b>	TAP_CFG1 register description . . . . .	100
<b>Table 168.</b>	TAP priority decoding . . . . .	100
<b>Table 169.</b>	TAP_CFG2 register . . . . .	100
<b>Table 170.</b>	TAP_CFG2 register description . . . . .	100
<b>Table 171.</b>	TAP_THS_6D register . . . . .	101
<b>Table 172.</b>	TAP_THS_6D register description . . . . .	101
<b>Table 173.</b>	Threshold for D4D/D6D function . . . . .	101
<b>Table 174.</b>	TAP_DUR register . . . . .	102
<b>Table 175.</b>	TAP_DUR register description . . . . .	102
<b>Table 176.</b>	WAKE_UP_THS register. . . . .	102
<b>Table 177.</b>	WAKE_UP_THS register description . . . . .	102
<b>Table 178.</b>	WAKE_UP_DUR register . . . . .	103
<b>Table 179.</b>	WAKE_UP_DUR register description . . . . .	103
<b>Table 180.</b>	FREE_FALL register . . . . .	103
<b>Table 181.</b>	FREE_FALL register description . . . . .	103
<b>Table 182.</b>	Threshold for free-fall function . . . . .	103
<b>Table 183.</b>	MD1_CFG register. . . . .	104
<b>Table 184.</b>	MD1_CFG register description. . . . .	104
<b>Table 185.</b>	MD2_CFG register. . . . .	105
<b>Table 186.</b>	MD2_CFG register description. . . . .	105
<b>Table 187.</b>	HAODR_CFG register . . . . .	105
<b>Table 188.</b>	HAODR_CFG register description . . . . .	105
<b>Table 189.</b>	EMB_FUNC_CFG register . . . . .	106
<b>Table 190.</b>	EMB_FUNC_CFG register description . . . . .	106
<b>Table 191.</b>	UI_HANDSHAKE_CTRL register . . . . .	106
<b>Table 192.</b>	UI_HANDSHAKE_CTRL register description . . . . .	106
<b>Table 193.</b>	UI_IF2_SHARED_0 register . . . . .	107
<b>Table 194.</b>	UI_IF2_SHARED_0 register description . . . . .	107
<b>Table 195.</b>	UI_IF2_SHARED_1 register . . . . .	107
<b>Table 196.</b>	UI_IF2_SHARED_1 register description . . . . .	107
<b>Table 197.</b>	UI_IF2_SHARED_2 register . . . . .	107
<b>Table 198.</b>	UI_IF2_SHARED_2 register description . . . . .	107
<b>Table 199.</b>	UI_IF2_SHARED_3 register . . . . .	108
<b>Table 200.</b>	UI_IF2_SHARED_3 register description . . . . .	108
<b>Table 201.</b>	UI_IF2_SHARED_4 register . . . . .	108
<b>Table 202.</b>	UI_IF2_SHARED_4 register description . . . . .	108
<b>Table 203.</b>	UI_IF2_SHARED_5 register . . . . .	108
<b>Table 204.</b>	UI_IF2_SHARED_5 register description . . . . .	108
<b>Table 205.</b>	CTRL_EIS register. . . . .	109
<b>Table 206.</b>	CTRL_EIS register description. . . . .	109
<b>Table 207.</b>	Gyroscope EIS chain digital LPF_EIS filter bandwidth selection . . . . .	109
<b>Table 208.</b>	XL_HG_X_OFS_USR register. . . . .	110
<b>Table 209.</b>	XL_HG_X_OFS_USR register description. . . . .	110
<b>Table 210.</b>	XL_HG_Y_OFS_USR register. . . . .	110
<b>Table 211.</b>	XL_HG_Y_OFS_USR register description. . . . .	110
<b>Table 212.</b>	XL_HG_Z_OFS_USR register . . . . .	110
<b>Table 213.</b>	XL_HG_Z_OFS_USR register description. . . . .	110
<b>Table 214.</b>	UI_INT_OIS register. . . . .	111
<b>Table 215.</b>	UI_INT_OIS register description. . . . .	111
<b>Table 216.</b>	UI_CTRL1_OIS register . . . . .	112
<b>Table 217.</b>	UI_CTRL1_OIS register description . . . . .	112
<b>Table 218.</b>	UI_CTRL2_OIS register . . . . .	113

<b>Table 219.</b>	UI_CTRL2_OIS register description . . . . .	113
<b>Table 220.</b>	Gyroscope OIS chain digital LPF1 filter bandwidth selection . . . . .	113
<b>Table 221.</b>	UI_CTRL3_OIS register . . . . .	114
<b>Table 222.</b>	UI_CTRL3_OIS register description . . . . .	114
<b>Table 223.</b>	Accelerometer OIS channel bandwidth and phase . . . . .	114
<b>Table 224.</b>	X_OFS_USR register . . . . .	115
<b>Table 225.</b>	X_OFS_USR register description . . . . .	115
<b>Table 226.</b>	Y_OFS_USR register . . . . .	115
<b>Table 227.</b>	Y_OFS_USR register description . . . . .	115
<b>Table 228.</b>	Z_OFS_USR register . . . . .	115
<b>Table 229.</b>	Z_OFS_USR register description . . . . .	115
<b>Table 230.</b>	FIFO_DATA_OUT_TAG register . . . . .	116
<b>Table 231.</b>	FIFO_DATA_OUT_TAG register description . . . . .	116
<b>Table 232.</b>	FIFO tag . . . . .	116
<b>Table 233.</b>	FIFO_DATA_OUT_X_H and FIFO_DATA_OUT_X_L registers . . . . .	117
<b>Table 234.</b>	FIFO_DATA_OUT_X_H and FIFO_DATA_OUT_X_L register description . . . . .	117
<b>Table 235.</b>	FIFO_DATA_OUT_Y_H and FIFO_DATA_OUT_Y_L registers . . . . .	117
<b>Table 236.</b>	FIFO_DATA_OUT_Y_H and FIFO_DATA_OUT_Y_L register description . . . . .	117
<b>Table 237.</b>	FIFO_DATA_OUT_Z_H and FIFO_DATA_OUT_Z_L registers . . . . .	117
<b>Table 238.</b>	FIFO_DATA_OUT_Z_H and FIFO_DATA_OUT_Z_L register description . . . . .	117
<b>Table 239.</b>	IF2 register address map . . . . .	118
<b>Table 240.</b>	IF2_WhoAml register . . . . .	119
<b>Table 241.</b>	IF2_STATUS_REG_OIS register . . . . .	119
<b>Table 242.</b>	IF2_STATUS_REG_OIS description . . . . .	119
<b>Table 243.</b>	IF2_OUT_TEMP_L register . . . . .	119
<b>Table 244.</b>	IF2_OUT_TEMP_H register . . . . .	119
<b>Table 245.</b>	IF2_OUT_TEMP register description . . . . .	119
<b>Table 246.</b>	IF2_OUTX_L_G_OIS register . . . . .	120
<b>Table 247.</b>	IF2_OUTX_H_G_OIS register . . . . .	120
<b>Table 248.</b>	IF2_OUTX_H_G_OIS register description . . . . .	120
<b>Table 249.</b>	IF2_OUTY_L_G_OIS register . . . . .	120
<b>Table 250.</b>	IF2_OUTY_H_G_OIS register . . . . .	120
<b>Table 251.</b>	IF2_OUTY_H_G_OIS register description . . . . .	120
<b>Table 252.</b>	IF2_OUTZ_L_G_OIS register . . . . .	121
<b>Table 253.</b>	IF2_OUTZ_H_G_OIS register . . . . .	121
<b>Table 254.</b>	IF2_OUTZ_H_G_OIS register description . . . . .	121
<b>Table 255.</b>	IF2_OUTX_L_A_OIS register . . . . .	121
<b>Table 256.</b>	IF2_OUTX_H_A_OIS register . . . . .	121
<b>Table 257.</b>	IF2_OUTX_H_A_OIS register description . . . . .	121
<b>Table 258.</b>	IF2_OUTY_L_A_OIS register . . . . .	122
<b>Table 259.</b>	IF2_OUTY_H_A_OIS register . . . . .	122
<b>Table 260.</b>	IF2_OUTY_H_A_OIS register description . . . . .	122
<b>Table 261.</b>	IF2_OUTZ_L_A_OIS register . . . . .	122
<b>Table 262.</b>	IF2_OUTZ_H_A_OIS register . . . . .	122
<b>Table 263.</b>	IF2_OUTZ_H_A_OIS register description . . . . .	122
<b>Table 264.</b>	IF2_HANDSHAKE_CTRL register . . . . .	122
<b>Table 265.</b>	IF2_HANDSHAKE_CTRL register description . . . . .	122
<b>Table 266.</b>	IF2_INT_OIS register . . . . .	123
<b>Table 267.</b>	IF2_INT_OIS register description . . . . .	123
<b>Table 268.</b>	IF2_CTRL1_OIS register . . . . .	124
<b>Table 269.</b>	IF2_CTRL1_OIS register description . . . . .	124
<b>Table 270.</b>	IF2_CTRL2_OIS register . . . . .	125
<b>Table 271.</b>	IF2_CTRL2_OIS register description . . . . .	125
<b>Table 272.</b>	Gyroscope OIS chain digital LPF1 filter bandwidth selection . . . . .	125
<b>Table 273.</b>	IF2_CTRL3_OIS register . . . . .	126

<b>Table 274.</b>	IF2_CTRL3_OIS register description . . . . .	126
<b>Table 275.</b>	Accelerometer OIS channel bandwidth and phase . . . . .	126
<b>Table 276.</b>	Register address map - embedded functions . . . . .	127
<b>Table 277.</b>	PAGE_SEL register . . . . .	130
<b>Table 278.</b>	PAGE_SEL register description . . . . .	130
<b>Table 279.</b>	EMB_FUNC_EN_A register . . . . .	130
<b>Table 280.</b>	EMB_FUNC_EN_A register description . . . . .	130
<b>Table 281.</b>	EMB_FUNC_EN_B register . . . . .	131
<b>Table 282.</b>	EMB_FUNC_EN_B register description . . . . .	131
<b>Table 283.</b>	EMB_FUNC_EXEC_STATUS register . . . . .	131
<b>Table 284.</b>	EMB_FUNC_EXEC_STATUS register description . . . . .	131
<b>Table 285.</b>	PAGE_ADDRESS register . . . . .	132
<b>Table 286.</b>	PAGE_ADDRESS register description . . . . .	132
<b>Table 287.</b>	PAGE_VALUE register . . . . .	132
<b>Table 288.</b>	PAGE_VALUE register description . . . . .	132
<b>Table 289.</b>	EMB_FUNC_INT1 register . . . . .	132
<b>Table 290.</b>	EMB_FUNC_INT1 register description . . . . .	132
<b>Table 291.</b>	FSM_INT1 register . . . . .	133
<b>Table 292.</b>	FSM_INT1 register description . . . . .	133
<b>Table 293.</b>	MLC_INT1 register . . . . .	134
<b>Table 294.</b>	MLC_INT1 register description . . . . .	134
<b>Table 295.</b>	EMB_FUNC_INT2 register . . . . .	134
<b>Table 296.</b>	EMB_FUNC_INT2 register description . . . . .	134
<b>Table 297.</b>	FSM_INT2 register . . . . .	135
<b>Table 298.</b>	FSM_INT2 register description . . . . .	135
<b>Table 299.</b>	MLC_INT2 register . . . . .	136
<b>Table 300.</b>	MLC_INT2 register description . . . . .	136
<b>Table 301.</b>	EMB_FUNC_STATUS register . . . . .	136
<b>Table 302.</b>	EMB_FUNC_STATUS register description . . . . .	136
<b>Table 303.</b>	FSM_STATUS register . . . . .	137
<b>Table 304.</b>	FSM_STATUS register description . . . . .	137
<b>Table 305.</b>	MLC_STATUS register . . . . .	137
<b>Table 306.</b>	MLC_STATUS register description . . . . .	137
<b>Table 307.</b>	PAGE_RW register . . . . .	138
<b>Table 308.</b>	PAGE_RW register description . . . . .	138
<b>Table 309.</b>	SFLP_GBIASX_H and SFLP_GBIASX_L registers . . . . .	139
<b>Table 310.</b>	SFLP_GBIASX_H and SFLP_GBIASX_L register description . . . . .	139
<b>Table 311.</b>	SFLP_GBIASY_H and SFLP_GBIASY_L registers . . . . .	139
<b>Table 312.</b>	SFLP_GBIASY_H and SFLP_GBIASY_L register description . . . . .	139
<b>Table 313.</b>	SFLP_GBIASZ_H and SFLP_GBIASZ_L registers . . . . .	139
<b>Table 314.</b>	SFLP_GBIASZ_H and SFLP_GBIASZ_L register description . . . . .	139
<b>Table 315.</b>	SFLP_GRAVX_H and SFLP_GRAVX_L registers . . . . .	140
<b>Table 316.</b>	SFLP_GRAVX_H and SFLP_GRAVX_L register description . . . . .	140
<b>Table 317.</b>	SFLP_GRAVY_H and SFLP_GRAVY_L registers . . . . .	140
<b>Table 318.</b>	SFLP_GRAVY_H and SFLP_GRAVY_L register description . . . . .	140
<b>Table 319.</b>	SFLP_GRAVZ_H and SFLP_GRAVZ_L registers . . . . .	140
<b>Table 320.</b>	SFLP_GRAVZ_H and SFLP_GRAVZ_L register description . . . . .	140
<b>Table 321.</b>	SFLP_QUATW_H and SFLP_QUATW_L registers . . . . .	141
<b>Table 322.</b>	SFLP_QUATW_H and SFLP_QUATW_L register description . . . . .	141
<b>Table 323.</b>	SFLP_QUATX_H and SFLP_QUATX_L registers . . . . .	141
<b>Table 324.</b>	SFLP_QUATX_H and SFLP_QUATX_L register description . . . . .	141
<b>Table 325.</b>	SFLP_QUATY_H and SFLP_QUATY_L registers . . . . .	141
<b>Table 326.</b>	SFLP_QUATY_H and SFLP_QUATY_L register description . . . . .	141
<b>Table 327.</b>	SFLP_QUATZ_H and SFLP_QUATZ_L registers . . . . .	142
<b>Table 328.</b>	SFLP_QUATZ_H and SFLP_QUATZ_L register description . . . . .	142

<b>Table 329.</b>	SFLP_GBIASX_INIT_H and SFLP_GBIASX_INIT_L registers . . . . .	142
<b>Table 330.</b>	SFLP_GBIASX_INIT_H and SFLP_GBIASX_INIT_L register description . . . . .	142
<b>Table 331.</b>	SFLP_GBIASY_INIT_H and SFLP_GBIASY_INIT_L registers . . . . .	142
<b>Table 332.</b>	SFLP_GBIASY_INIT_H and SFLP_GBIASY_INIT_L register description . . . . .	142
<b>Table 333.</b>	SFLP_GBIASZ_INIT_H and SFLP_GBIASZ_INIT_L registers . . . . .	143
<b>Table 334.</b>	SFLP_GBIASZ_INIT_H and SFLP_GBIASZ_INIT_L register description . . . . .	143
<b>Table 335.</b>	EMB_FUNC_FIFO_EN_A register . . . . .	143
<b>Table 336.</b>	EMB_FUNC_FIFO_EN_A register description . . . . .	143
<b>Table 337.</b>	EMB_FUNC_FIFO_EN_B register . . . . .	144
<b>Table 338.</b>	EMB_FUNC_FIFO_EN_B register description . . . . .	144
<b>Table 339.</b>	FSM_ENABLE register . . . . .	144
<b>Table 340.</b>	FSM_ENABLE register description . . . . .	144
<b>Table 341.</b>	FSM_LONG_COUNTER_L register . . . . .	145
<b>Table 342.</b>	FSM_LONG_COUNTER_L register description . . . . .	145
<b>Table 343.</b>	FSM_LONG_COUNTER_H register . . . . .	145
<b>Table 344.</b>	FSM_LONG_COUNTER_H register description . . . . .	145
<b>Table 345.</b>	INT_ACK_MASK register . . . . .	146
<b>Table 346.</b>	INT_ACK_MASK register description . . . . .	146
<b>Table 347.</b>	FSM_OUTS1 register . . . . .	147
<b>Table 348.</b>	FSM_OUTS1 register description . . . . .	147
<b>Table 349.</b>	FSM_OUTS2 register . . . . .	147
<b>Table 350.</b>	FSM_OUTS2 register description . . . . .	147
<b>Table 351.</b>	FSM_OUTS3 register . . . . .	148
<b>Table 352.</b>	FSM_OUTS3 register description . . . . .	148
<b>Table 353.</b>	FSM_OUTS4 register . . . . .	148
<b>Table 354.</b>	FSM_OUTS4 register description . . . . .	148
<b>Table 355.</b>	FSM_OUTS5 register . . . . .	149
<b>Table 356.</b>	FSM_OUTS5 register description . . . . .	149
<b>Table 357.</b>	FSM_OUTS6 register . . . . .	149
<b>Table 358.</b>	FSM_OUTS6 register description . . . . .	149
<b>Table 359.</b>	FSM_OUTS7 register . . . . .	150
<b>Table 360.</b>	FSM_OUTS7 register description . . . . .	150
<b>Table 361.</b>	FSM_OUTS8 register . . . . .	150
<b>Table 362.</b>	FSM_OUTS8 register description . . . . .	150
<b>Table 363.</b>	SFLP_ODR register . . . . .	151
<b>Table 364.</b>	SFLP_ODR register description . . . . .	151
<b>Table 365.</b>	FSM_ODR register . . . . .	151
<b>Table 366.</b>	FSM_ODR register description . . . . .	151
<b>Table 367.</b>	MLC_ODR register . . . . .	152
<b>Table 368.</b>	MLC_ODR register description . . . . .	152
<b>Table 369.</b>	STEP_COUNTER_L register . . . . .	152
<b>Table 370.</b>	STEP_COUNTER_L register description . . . . .	152
<b>Table 371.</b>	STEP_COUNTER_H register . . . . .	152
<b>Table 372.</b>	STEP_COUNTER_H register description . . . . .	152
<b>Table 373.</b>	EMB_FUNC_SRC register . . . . .	153
<b>Table 374.</b>	EMB_FUNC_SRC register description . . . . .	153
<b>Table 375.</b>	EMB_FUNC_INIT_A register . . . . .	154
<b>Table 376.</b>	EMB_FUNC_INIT_A register description . . . . .	154
<b>Table 377.</b>	EMB_FUNC_INIT_B register . . . . .	154
<b>Table 378.</b>	EMB_FUNC_INIT_B register description . . . . .	154
<b>Table 379.</b>	EMB_FUNC_SENSOR_CONV_EN register . . . . .	154
<b>Table 380.</b>	EMB_FUNC_SENSOR_CONV_EN register description . . . . .	154
<b>Table 381.</b>	MLC1_SRC register . . . . .	155
<b>Table 382.</b>	MLC1_SRC register description . . . . .	155
<b>Table 383.</b>	MLC2_SRC register . . . . .	155

<b>Table 384.</b>	MLC2_SRC register description . . . . .	155
<b>Table 385.</b>	MLC3_SRC register . . . . .	155
<b>Table 386.</b>	MLC3_SRC register description . . . . .	155
<b>Table 387.</b>	MLC4_SRC register . . . . .	155
<b>Table 388.</b>	MLC4_SRC register description . . . . .	155
<b>Table 389.</b>	MLC5_SRC register . . . . .	156
<b>Table 390.</b>	MLC5_SRC register description . . . . .	156
<b>Table 391.</b>	MLC6_SRC register . . . . .	156
<b>Table 392.</b>	MLC6_SRC register description . . . . .	156
<b>Table 393.</b>	MLC7_SRC register . . . . .	156
<b>Table 394.</b>	MLC7_SRC register description . . . . .	156
<b>Table 395.</b>	MLC8_SRC register . . . . .	156
<b>Table 396.</b>	MLC8_SRC register description . . . . .	156
<b>Table 397.</b>	Register address map - embedded advanced features page 0 . . . . .	157
<b>Table 398.</b>	Register address map - embedded advanced features page 1 . . . . .	158
<b>Table 399.</b>	Register address map - embedded advanced features page 2 . . . . .	158
<b>Table 400.</b>	FSM_EXT_SENSITIVITY_L register . . . . .	160
<b>Table 401.</b>	FSM_EXT_SENSITIVITY_L register description . . . . .	160
<b>Table 402.</b>	FSM_EXT_SENSITIVITY_H register . . . . .	160
<b>Table 403.</b>	FSM_EXT_SENSITIVITY_H register description . . . . .	160
<b>Table 404.</b>	FSM_EXT_OFFX_L register . . . . .	161
<b>Table 405.</b>	FSM_EXT_OFFX_L register description . . . . .	161
<b>Table 406.</b>	FSM_EXT_OFFX_H register . . . . .	161
<b>Table 407.</b>	FSM_EXT_OFFX_H register description . . . . .	161
<b>Table 408.</b>	FSM_EXT_OFFY_L register . . . . .	161
<b>Table 409.</b>	FSM_EXT_OFFY_L register description . . . . .	161
<b>Table 410.</b>	FSM_EXT_OFFY_H register . . . . .	161
<b>Table 411.</b>	FSM_EXT_OFFY_H register description . . . . .	161
<b>Table 412.</b>	FSM_EXT_OFFZ_L register . . . . .	162
<b>Table 413.</b>	FSM_EXT_OFFZ_L register description . . . . .	162
<b>Table 414.</b>	FSM_EXT_OFFZ_H register . . . . .	162
<b>Table 415.</b>	FSM_EXT_OFFZ_H register description . . . . .	162
<b>Table 416.</b>	FSM_EXT_MATRIX_XX_L register . . . . .	162
<b>Table 417.</b>	FSM_EXT_MATRIX_XX_L register description . . . . .	162
<b>Table 418.</b>	FSM_EXT_MATRIX_XX_H register . . . . .	162
<b>Table 419.</b>	FSM_EXT_MATRIX_XX_H register description . . . . .	162
<b>Table 420.</b>	FSM_EXT_MATRIX_XY_L register . . . . .	163
<b>Table 421.</b>	FSM_EXT_MATRIX_XY_L register description . . . . .	163
<b>Table 422.</b>	FSM_EXT_MATRIX_XY_H register . . . . .	163
<b>Table 423.</b>	FSM_EXT_MATRIX_XY_H register description . . . . .	163
<b>Table 424.</b>	FSM_EXT_MATRIX_XZ_L register . . . . .	163
<b>Table 425.</b>	FSM_EXT_MATRIX_XZ_L register description . . . . .	163
<b>Table 426.</b>	FSM_EXT_MATRIX_XZ_H register . . . . .	163
<b>Table 427.</b>	FSM_EXT_MATRIX_XZ_H register description . . . . .	163
<b>Table 428.</b>	FSM_EXT_MATRIX_YY_L register . . . . .	164
<b>Table 429.</b>	FSM_EXT_MATRIX_YY_L register description . . . . .	164
<b>Table 430.</b>	FSM_EXT_MATRIX_YY_H register . . . . .	164
<b>Table 431.</b>	FSM_EXT_MATRIX_YY_H register description . . . . .	164
<b>Table 432.</b>	FSM_EXT_MATRIX_YZ_L register . . . . .	164
<b>Table 433.</b>	FSM_EXT_MATRIX_YZ_L register description . . . . .	164
<b>Table 434.</b>	FSM_EXT_MATRIX_YZ_H register . . . . .	164
<b>Table 435.</b>	FSM_EXT_MATRIX_YZ_H register description . . . . .	164
<b>Table 436.</b>	FSM_EXT_MATRIX_ZZ_L register . . . . .	165
<b>Table 437.</b>	FSM_EXT_MATRIX_ZZ_L register description . . . . .	165
<b>Table 438.</b>	FSM_EXT_MATRIX_ZZ_H register . . . . .	165

<b>Table 439.</b>	FSM_EXT_MATRIX_ZZ_H register description	165
<b>Table 440.</b>	EXT_CFG_A register	166
<b>Table 441.</b>	EXT_CFG_A description	166
<b>Table 442.</b>	EXT_CFG_B register	166
<b>Table 443.</b>	EXT_CFG_B description	166
<b>Table 444.</b>	XL_HG_SENSITIVITY_L register	167
<b>Table 445.</b>	XL_HG_SENSITIVITY_L register description	167
<b>Table 446.</b>	XL_HG_SENSITIVITY_H register	167
<b>Table 447.</b>	XL_HG_SENSITIVITY_H register description	167
<b>Table 448.</b>	FSM_LC_TIMEOUT_L register	167
<b>Table 449.</b>	FSM_LC_TIMEOUT_L register description	167
<b>Table 450.</b>	FSM_LC_TIMEOUT_H register	167
<b>Table 451.</b>	FSM_LC_TIMEOUT_H register description	167
<b>Table 452.</b>	FSM_PROGRAMS register	168
<b>Table 453.</b>	FSM_PROGRAMS register description	168
<b>Table 454.</b>	FSM_START_ADD_L register	168
<b>Table 455.</b>	FSM_START_ADD_L register description	168
<b>Table 456.</b>	FSM_START_ADD_H register	168
<b>Table 457.</b>	FSM_START_ADD_H register description	168
<b>Table 458.</b>	PEDO_CMD_REG register	169
<b>Table 459.</b>	PEDO_CMD_REG register description	169
<b>Table 460.</b>	PEDO_DEB_STEPS_CONF register	169
<b>Table 461.</b>	PEDO_DEB_STEPS_CONF register description	169
<b>Table 462.</b>	PEDO_SC_DELTAT_L register	169
<b>Table 463.</b>	PEDO_SC_DELTAT_H register	169
<b>Table 464.</b>	PEDO_SC_DELTAT_H/L register description	169
<b>Table 465.</b>	MLC_EXT_SENSITIVITY_L register	170
<b>Table 466.</b>	MLC_EXT_SENSITIVITY_L register description	170
<b>Table 467.</b>	MLC_EXT_SENSITIVITY_H register	170
<b>Table 468.</b>	MLC_EXT_SENSITIVITY_H register description	170
<b>Table 469.</b>	EXT_FORMAT register	171
<b>Table 470.</b>	EXT_FORMAT register description	171
<b>Table 471.</b>	EXT_3BYTE_SENSITIVITY_L register	171
<b>Table 472.</b>	EXT_3BYTE_SENSITIVITY_L register description	171
<b>Table 473.</b>	EXT_3BYTE_SENSITIVITY_H register	171
<b>Table 474.</b>	EXT_3BYTE_SENSITIVITY_H register description	171
<b>Table 475.</b>	EXT_3BYTE_OFFSET_XL register	172
<b>Table 476.</b>	EXT_3BYTE_OFFSET_XL register description	172
<b>Table 477.</b>	EXT_3BYTE_OFFSET_L register	172
<b>Table 478.</b>	EXT_3BYTE_OFFSET_L register description	172
<b>Table 479.</b>	EXT_3BYTE_OFFSET_H register	172
<b>Table 480.</b>	EXT_3BYTE_OFFSET_H register description	172
<b>Table 481.</b>	Register address map - sensor hub registers	173
<b>Table 482.</b>	SENSOR_HUB_1 register	174
<b>Table 483.</b>	SENSOR_HUB_1 register description	174
<b>Table 484.</b>	SENSOR_HUB_2 register	174
<b>Table 485.</b>	SENSOR_HUB_2 register description	174
<b>Table 486.</b>	SENSOR_HUB_3 register	174
<b>Table 487.</b>	SENSOR_HUB_3 register description	174
<b>Table 488.</b>	SENSOR_HUB_4 register	175
<b>Table 489.</b>	SENSOR_HUB_4 register description	175
<b>Table 490.</b>	SENSOR_HUB_5 register	175
<b>Table 491.</b>	SENSOR_HUB_5 register description	175
<b>Table 492.</b>	SENSOR_HUB_6 register	175
<b>Table 493.</b>	SENSOR_HUB_6 register description	175



<b>Table 494.</b>	SENSOR_HUB_7 register . . . . .	176
<b>Table 495.</b>	SENSOR_HUB_7 register description . . . . .	176
<b>Table 496.</b>	SENSOR_HUB_8 register . . . . .	176
<b>Table 497.</b>	SENSOR_HUB_8 register description . . . . .	176
<b>Table 498.</b>	SENSOR_HUB_9 register . . . . .	176
<b>Table 499.</b>	SENSOR_HUB_9 register description . . . . .	176
<b>Table 500.</b>	SENSOR_HUB_10 register . . . . .	177
<b>Table 501.</b>	SENSOR_HUB_10 register description . . . . .	177
<b>Table 502.</b>	SENSOR_HUB_11 register . . . . .	177
<b>Table 503.</b>	SENSOR_HUB_11 register description . . . . .	177
<b>Table 504.</b>	SENSOR_HUB_12 register . . . . .	177
<b>Table 505.</b>	SENSOR_HUB_12 register description . . . . .	177
<b>Table 506.</b>	SENSOR_HUB_13 register . . . . .	178
<b>Table 507.</b>	SENSOR_HUB_13 register description . . . . .	178
<b>Table 508.</b>	SENSOR_HUB_14 register . . . . .	178
<b>Table 509.</b>	SENSOR_HUB_14 register description . . . . .	178
<b>Table 510.</b>	SENSOR_HUB_15 register . . . . .	178
<b>Table 511.</b>	SENSOR_HUB_15 register description . . . . .	178
<b>Table 512.</b>	SENSOR_HUB_16 register . . . . .	179
<b>Table 513.</b>	SENSOR_HUB_16 register description . . . . .	179
<b>Table 514.</b>	SENSOR_HUB_17 register . . . . .	179
<b>Table 515.</b>	SENSOR_HUB_17 register description . . . . .	179
<b>Table 516.</b>	SENSOR_HUB_17 register . . . . .	179
<b>Table 517.</b>	SENSOR_HUB_17 register description . . . . .	179
<b>Table 518.</b>	CONTROLLER_CONFIG register . . . . .	180
<b>Table 519.</b>	CONTROLLER_CONFIG register description . . . . .	180
<b>Table 520.</b>	TGT0_ADD register . . . . .	181
<b>Table 521.</b>	TGT0_ADD register description . . . . .	181
<b>Table 522.</b>	TGT0_SUBADD register . . . . .	181
<b>Table 523.</b>	TGT0_SUBADD register description . . . . .	181
<b>Table 524.</b>	TGT0_CONFIG register . . . . .	181
<b>Table 525.</b>	TGT0_CONFIG register description . . . . .	181
<b>Table 526.</b>	TGT1_ADD register . . . . .	182
<b>Table 527.</b>	TGT1_ADD register description . . . . .	182
<b>Table 528.</b>	TGT1_SUBADD register . . . . .	182
<b>Table 529.</b>	TGT1_SUBADD register description . . . . .	182
<b>Table 530.</b>	TGT1_CONFIG register . . . . .	182
<b>Table 531.</b>	TGT1_CONFIG register description . . . . .	182
<b>Table 532.</b>	TGT2_ADD register . . . . .	183
<b>Table 533.</b>	TGT2_ADD register description . . . . .	183
<b>Table 534.</b>	TGT2_SUBADD register . . . . .	183
<b>Table 535.</b>	TGT2_SUBADD register description . . . . .	183
<b>Table 536.</b>	TGT2_CONFIG register . . . . .	183
<b>Table 537.</b>	TGT2_CONFIG register description . . . . .	183
<b>Table 538.</b>	TGT3_ADD register . . . . .	184
<b>Table 539.</b>	TGT3_ADD register description . . . . .	184
<b>Table 540.</b>	TGT3_SUBADD register . . . . .	184
<b>Table 541.</b>	TGT3_SUBADD register description . . . . .	184
<b>Table 542.</b>	TGT3_CONFIG register . . . . .	184
<b>Table 543.</b>	TGT3_CONFIG register description . . . . .	184
<b>Table 544.</b>	DATAWRITE_TGT0 register . . . . .	185
<b>Table 545.</b>	DATAWRITE_TGT0 register description . . . . .	185
<b>Table 546.</b>	STATUS_CONTROLLER register . . . . .	185
<b>Table 547.</b>	STATUS_CONTROLLER register description . . . . .	185
<b>Table 548.</b>	Reel dimensions for carrier tape of LGA-14L package . . . . .	189



**Table 549.** Document revision history . . . . . 190

## List of figures

<b>Figure 1.</b>	Generic state machine . . . . .	5
<b>Figure 2.</b>	State machine in the ISM6HG256X . . . . .	5
<b>Figure 3.</b>	Machine learning core in the ISM6HG256X . . . . .	6
<b>Figure 4.</b>	Four-stage pedometer algorithm . . . . .	8
<b>Figure 5.</b>	Pin connections . . . . .	9
<b>Figure 6.</b>	ISM6HG256X connection modes . . . . .	10
<b>Figure 7.</b>	SPI target timing in mode 0 . . . . .	18
<b>Figure 8.</b>	SPI target timing in mode 3 . . . . .	18
<b>Figure 9.</b>	I <sup>2</sup> C target timing diagram . . . . .	19
<b>Figure 10.</b>	Read and write protocol (in mode 3) . . . . .	25
<b>Figure 11.</b>	SPI read protocol (in mode 3) . . . . .	26
<b>Figure 12.</b>	Multiple byte SPI read protocol (2-byte example) (in mode 3) . . . . .	26
<b>Figure 13.</b>	SPI write protocol (in mode 3) . . . . .	27
<b>Figure 14.</b>	Multiple byte SPI write protocol (2-byte example) (in mode 3) . . . . .	27
<b>Figure 15.</b>	SPI read protocol in 3-wire mode (in mode 3) . . . . .	27
<b>Figure 16.</b>	Single-channel mode (XL_DualC_EN = 0) . . . . .	33
<b>Figure 17.</b>	High-g accelerometer filter . . . . .	34
<b>Figure 18.</b>	Block diagram of filters . . . . .	37
<b>Figure 19.</b>	Low-g accelerometer UI chain . . . . .	38
<b>Figure 20.</b>	Low-g accelerometer composite filter . . . . .	38
<b>Figure 21.</b>	Accelerometer chain with mode 3 enabled . . . . .	39
<b>Figure 22.</b>	Gyroscope digital chain - mode 1 (UI/EIS) and mode 2 . . . . .	40
<b>Figure 23.</b>	Gyroscope digital chain - mode 3 (OIS) . . . . .	41
<b>Figure 24.</b>	ISM6HG256X supports UI, enhanced EIS, and OIS processing simultaneously. . . . .	42
<b>Figure 25.</b>	Gyroscope enhanced EIS and UI block diagram . . . . .	42
<b>Figure 26.</b>	Auxiliary interface full control . . . . .	44
<b>Figure 27.</b>	OIS primary interface full control . . . . .	45
<b>Figure 28.</b>	ISM6HG256X electrical connections in mode 1 . . . . .	49
<b>Figure 29.</b>	ISM6HG256X electrical connections in mode 2 . . . . .	50
<b>Figure 30.</b>	ISM6HG256X electrical connections in mode 3 (auxiliary 3/4-wire SPI or auxiliary MIPI I3C). . . . .	51
<b>Figure 31.</b>	Accelerometer block diagram . . . . .	75
<b>Figure 32.</b>	LGA-14L 2.5 x 3.0 x 0.83 mm package outline and mechanical data . . . . .	187
<b>Figure 33.</b>	Carrier tape information for LGA-14L package . . . . .	188
<b>Figure 34.</b>	LGA-14L package orientation in carrier tape . . . . .	188
<b>Figure 35.</b>	Reel information for carrier tape of LGA-14L package . . . . .	189

**IMPORTANT NOTICE – READ CAREFULLY**

STMicroelectronics NV and its subsidiaries (“ST”) reserve the right to make changes, corrections, enhancements, modifications, and improvements to ST products and/or to this document at any time without notice.

In the event of any conflict between the provisions of this document and the provisions of any contractual arrangement in force between the purchasers and ST, the provisions of such contractual arrangement shall prevail.

The purchasers should obtain the latest relevant information on ST products before placing orders. ST products are sold pursuant to ST's terms and conditions of sale in place at the time of order acknowledgment.

The purchasers are solely responsible for the choice, selection, and use of ST products and ST assumes no liability for application assistance or the design of the purchasers' products.

No license, express or implied, to any intellectual property right is granted by ST herein.

Resale of ST products with provisions different from the information set forth herein shall void any warranty granted by ST for such product.

If the purchasers identify an ST product that meets their functional and performance requirements but that is not designated for the purchasers' market segment, the purchasers shall contact ST for more information.

ST and the ST logo are trademarks of ST. For additional information about ST trademarks, refer to [www.st.com/trademarks](http://www.st.com/trademarks). All other product or service names are the property of their respective owners.

Information in this document supersedes and replaces information previously supplied in any prior versions of this document.

© 2025 STMicroelectronics – All rights reserved